



# MAQRF112

**Automotive, 300MHz to 450MHz,  
+10dBm, 1.8V to 3.6V, ASK/FSK  
Transmitter with Shutdown**

## General Description

The MAQRF112 is a high-performance, easy to use, true "Data-In, RF-Out", ASK/FSK, phase-locked loop (PLL) based, transmitter IC for automotive applications in the 300MHz to 450MHz frequency range. These applications include remote keyless entry (RKE) and tire pressure monitoring systems (TPMS). The device needs only a low-cost crystal to precisely set the desired RF frequency, and a few external components for matching the power amplifier output to the antenna.

The MAQRF112 operates over the 1.8V to 3.6V operating range. It delivers +10dBm (CW) output power into a 50Ω load, while consuming 11.5mA of supply current from a 3.0V power supply. In ASK mode, the device consumes 6.9mA of supply current at a data rate of 1kbps (Manchester 50%). It features a low-power shutdown mode in which the device typically consumes 50nA of supply current. This makes it an ideal solution for battery powered applications.

The MAQRF112 is Automotive Qualified (AEC-Q100) and is rated to operate over the -40°C to +125°C temperature range. For non-automotive applications that do not require AEC-Q100 qualification, consider the MICRF112. For ASK-only applications that do not require shutdown, consider the MICRF113 in SOT23-6.

Datasheets and support documentation are available on Micrel's web site at: [www.micrel.com](http://www.micrel.com).

## Typical Application

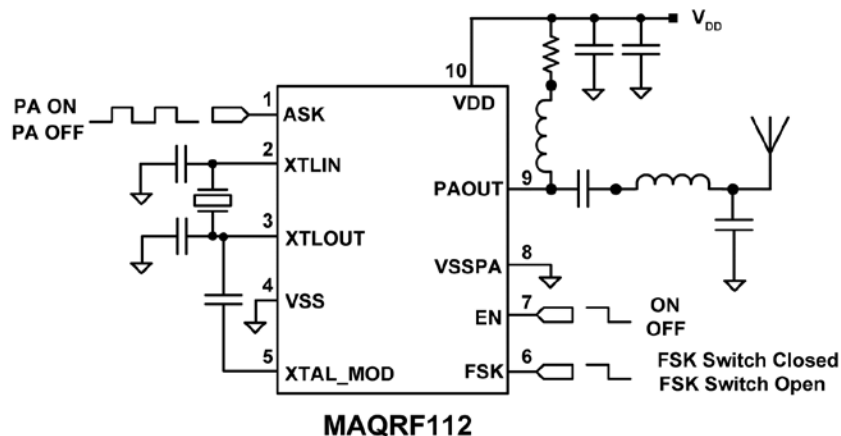

## Features

- AEC-Q100 Automotive Qualified
- 300MHz to 450MHz frequency range
- Data rates up to 50kbps ASK/10kbps FSK
- 1.8V to 3.6V operating voltage range
- +10dBm output power (CW) at 3.0V
- 11.5mA of supply current at +10dBm (CW)
- 6.9mA of supply current at 1kbps (ASK, Manchester)
- 50nA supply current in shutdown mode
- Needs only one crystal to set the desired RF frequency
- -40°C to +125°C operating temperature range
- 10-pin MSOP package (4.9mm x 3.0mm)

## Applications

- Remote keyless entry systems (RKE)
- Tire pressure monitoring systems (TPMS)

## Ordering Information

Part Number	Temp. Range	Package
MAQRF112YMM	-40°C to +125°C	10-Pin MSOP

## Pin Configuration

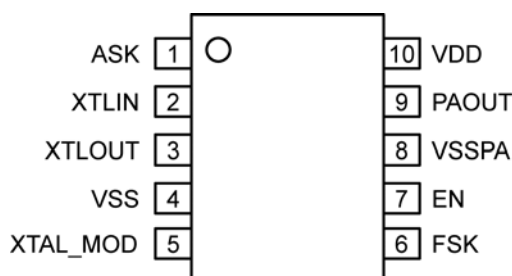

10-Pin MSOP (YMM)

## Pin Description

Pin Number	Pin Name	Pin Function
1	ASK	ASK Data Input and PA Enable. When EN is set to a logic-level HIGH and ASK is set to a logic-level HIGH, the power amplifier (PA) is enabled. A logic-level LOW on ASK disables the power amplifier. Apply a data stream less than 50Kbps (Manchester Encoded, 50% duty-cycle) for ASK modulation. To transmit with FSK modulation, both EN and ASK need to be set to a logic-level HIGH, while the FSK pin is modulated.
2	XTLIN	Reference Oscillator Input Connection. Connect a crystal between XTLIN and XTLOUT. Connect a load capacitor from XTLIN to ground, based on the recommendations of the crystal manufacturer.
3	XTLOUT	Reference Oscillator Output Connection. Connect a crystal between XTLIN and XTLOUT. Connect a load capacitor from XTLOUT to ground, based on the recommendations of the crystal manufacturer.
4	VSS	Ground.
5	XTAL_MOD	FSK Crystal Pulling Switch Connection. For FSK modulation, connect a capacitor between the XTAL_MOD pin and XTLOUT. For ASK-only operation, this pin can be left unconnected.
6	FSK	FSK Data Input. A logic-level LOW opens the FSK crystal pulling switch, providing high impedance (>1M $\Omega$ ) between the XTAL_MOD pin and VSS (ground). A logic-level HIGH closes the switch, providing low impedance (15 $\Omega$ ) between XTAL_MOD and VSS (ground). This parallels the crystal pulling capacitor, C <sub>FSK</sub> , with the crystal load capacitor, C <sub>LOAD</sub> , and pulls the reference frequency to achieve FSK modulation. For ASK-only operation, pulling this pin low is recommended.
7	EN	Enable/Shutdown Input. A logic-level LOW disables the entire device, placing it in a low-power shutdown mode. A logic-level HIGH enables the crystal oscillator, PLL, voltage-controlled oscillator (VCO), and control blocks, if the supply voltage is above the undervoltage lockout (UVLO) voltage. The power amplifier is enabled when a logic-level HIGH is applied to EN and ASK.
8	VSSPA	Power Amplifier Ground.
9	PAOUT	Open Collector of Power Amplifier Output. Pull the PA_OUT pin to VDD through an inductor to properly bias the output stage. Add a pull-up resistor in series to reduce bias current and to achieve lower output power and lower supply current operation. A matching network is required to match the output to desired load (PCB antenna, wire antenna, or 50 $\Omega$ load) to achieve best output power, supply current, and spectral performance. See the "Applications Information" section for recommended power supply bypassing.
10	VDD	Power Supply for Crystal Oscillator, Phase-Locked Loop, Voltage-Controlled Oscillator, and Control Blocks. See the "Applications Information" section for recommended power supply bypassing.

### Absolute Maximum Ratings<sup>(1)</sup>

Supply Voltage ( $V_{VDD}$ )	+4.3V
Voltage on PAOUT ( $V_{PAOUT}$ )	+7.2V
Logic Inputs ( $V_{ASK}, V_{FSK}, V_{EN}$ )	$V_{VSS} - 0.3$ to $V_{VDD} + 0.3$ V
Storage Temperature Range	-65°C to +150°C
Lead Temperature (soldering, 10s)	+260°C
ESD Rating	Note 3

### Operating Ratings<sup>(2)</sup>

Supply Voltage ( $V_{VDD}, V_{PAOUT}$ )	+1.8V to +3.6V
Input Voltage ( $V_{ASK}, V_{FSK}, V_{EN}$ )	0V to $V_{VDD}$
Junction Temperature ( $T_J$ )	-40°C to +125°C
Transmitter Frequency Range ( $f_{RF}$ )	300MHz to 450MHz
Thermal Resistance, ( $\theta_{JA}$ )	130°C/W

### Electrical Characteristics<sup>(4)</sup>

$V_{VDD} = 3.0$ V,  $T_A = +25$ °C,  $f_{REFOSC} = 9.84375$ MHz for 315MHz,  $f_{REFOSC} = 13.560$ MHz for 433.92MHz, ASK = EN = VDD.  
 MICRF/MAQRF112 50Ω Evaluation Board. Bold values indicate  $T_A = -40$ °C to +125°C unless otherwise noted. 1Kbps data rate, 50% duty cycle, pulse width = 500μs.

Parameter	Condition	Min	Typ	Max	Units	
<b>Power Supply</b>						
Standby Supply Current	$V_{VDD} = 3.6$ V, $V_{EN} = 0$ V		0.05	<b>3</b>	μA	
Mark Supply Current	$f_{RF} = 315$ MHz	$V_{VDD} = V_{ASK} = 3.0$ V		11.5	mA	
		$V_{VDD} = V_{ASK} = 3.6$ V		12.1	<b>14.5</b>	mA
	$f_{RF} = 433.92$ MHz	$V_{VDD} = V_{ASK} = 3.0$ V		11.6		mA
		$V_{VDD} = V_{ASK} = 3.6$ V		12.1	<b>15.0</b>	mA
SPACE Supply Current	$f_{RF} = 315$ MHz	$V_{VDD} = 3.0$ V, $V_{ASK} = 0$ V		2.4	mA	
		$V_{VDD} = 3.6$ V, $V_{ASK} = 0$ V		2.5	<b>3.5</b>	mA
	$f_{RF} = 433.92$ MHz	$V_{VDD} = 3.0$ V, $V_{ASK} = 0$ V		2.7		mA
		$V_{VDD} = 3.6$ V, $V_{ASK} = 0$ V		2.8	<b>3.8</b>	mA
ASK Modulated Supply Current	$f_{RF} = 315$ MHz	$V_{VDD} = 3.0$ V, $V_{ASK} = 1$ kHz		6.9	mA	
	$f_{RF} = 433.92$ MHz	$V_{VDD} = 3.0$ V, $V_{ASK} = 1$ kHz		7.2	mA	
<b>RF Output Section and Modulation Limits</b>						
Output Power Level	$V_{ASK} = 3.0$ V	$f_{RF} = 315$ MHz	<b>5</b>	10		dBm
		$f_{RF} = 433.92$ MHz	<b>6</b>	10		dBm
Harmonic Output	$f_{RF} = 315$ MHz	$f_{HARMONIC} = 630$ MHz		-53		dBc
		$f_{HARMONIC} = 945$ MHz		-53		dBc
	$f_{RF} = 433.92$ MHz	$f_{HARMONIC} = 867.84$ MHz		-51		dBc
		$f_{HARMONIC} = 1301.76$ MHz		-65		dBc
Extinction Ratio for ASK	$f_{RF} = 315$ MHz			80		dBc
	$f_{RF} = 433.92$ MHz			90		dBc
<b>FSK Modulation</b>						
Maximum Data Rate	Manchester Encoded (50% Duty Cycle) <sup>(4)</sup>		10			Kbps
Maximum Frequency Deviation	Crystal = HC49/US, load capacitor = 10pF <sup>(4)</sup>		±25			kHz
XTAL_MOD to VSS Impedance, RDSon	FSK = VSS	<b>1</b>				MΩ
	FSK = VDD		15	<b>35</b>		Ω
<b>ASK Modulation</b>						
Maximum Data Rate	Manchester Encoded (50% Duty Cycle)		50			kbps

Parameter	Condition	Min	Typ	Max	Units	
Occupied Bandwidth	$f_{RF} = 315\text{MHz}^{(5)}$		630		kHz	
	$f_{RF} = 433.92\text{MHz}^{(5)}$		670		kHz	
<b>VCO Section</b>						
Single Side-Band Phase Noise	$f_{RF} = 315\text{MHz}$	$f_{\text{OFFSET}} = 100\text{kHz}$		-76		dBc/Hz
		$f_{\text{OFFSET}} = 1000\text{kHz}$		-79		dBc/Hz
	$f_{RF} = 433.92\text{MHz}$	$f_{\text{OFFSET}} = 100\text{kHz}$		-72		dBc/Hz
		$f_{\text{OFFSET}} = 1000\text{kHz}$		-81		dBc/Hz
<b>Reference Oscillator Section</b>						
XTLIN, XTLOUT, XTLMOD	Pin capacitance		2		pF	
Oscillator Start-Up Time	Crystal: HC49S, Note 4		400		$\mu\text{s}$	
<b>Digital/Control Section</b>						
Digital Input Threshold Voltage (EN, ASK, and FSK)	High ( $V_{IH}$ )	<b>0.8V<sub>DD</sub></b>			V	
	Low ( $V_{IL}$ )			<b>0.2V<sub>DD</sub></b>	V	
Digital Input Current (EN, ASK, and FSK)	High ( $I_{IH}$ ), $V_{DD} = 3.6\text{V}$		0.05	<b>1</b>	$\mu\text{A}$	
	Low ( $I_{IL}$ ), $V_{DD} = 3.6\text{V}$		0.05	<b>1</b>	$\mu\text{A}$	
Supply Undervoltage Lock Out (UVLO)			1.6		V	

**Notes:**

1. Exceeding the absolute maximum ratings can damage the device.
2. The device is not guaranteed to function outside its operating ratings.
3. Devices are ESD sensitive. Handling precautions are recommended. Human body model, 1.5k $\Omega$  in series with 100pF.
4. Dependent on crystal.
5. RBW = 100kHz, OBW measured at -20dBc.
6. Data rate = 50kbps, pulse width = 10 $\mu\text{s}$ , pulse repetition time = 20 $\mu\text{s}$ .

## Typical Characteristics

(MAQRF112, 50Ω Evaluation Board,  $V_{DD} = 3.0V$ ,  $V_{ASK} = V_{EN} = V_{DD}$ ,  $T_A = +25^\circ C$  unless otherwise noted)

**Supply Current vs. Supply Voltage**  
 $f_{RF} = 315MHz$ ,  $V_{ASK} = V_{DD}$

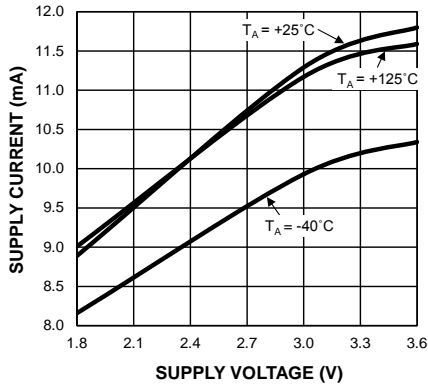

**Supply Current vs. Supply Voltage**  
 $f_{RF} = 315MHz$ ,  $V_{ASK} = GND$

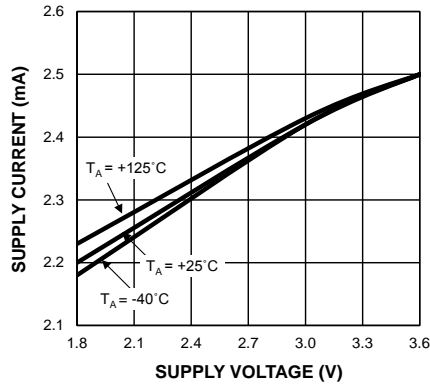

**ASK Modulated Supply Current vs. Supply Voltage**  
 $f_{RF} = 315MHz$ ,  $V_{ASK} = 1Kbps (50\%)$

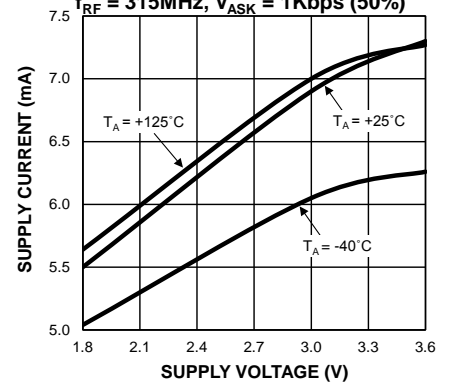

**Output Power vs. Supply Voltage**  
 $f_{RF} = 315MHz$ ,  $V_{ASK} = V_{DD}$

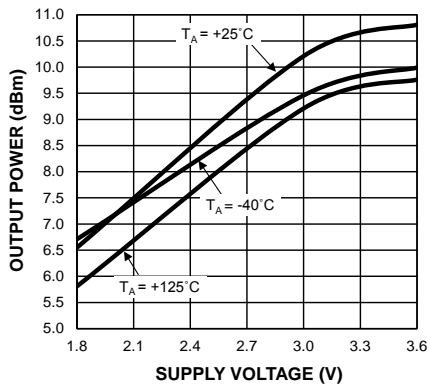

**2nd Harmonic vs. Supply Voltage**  
 $f_{RF} = 315MHz$ ,  $V_{ASK} = V_{DD}$

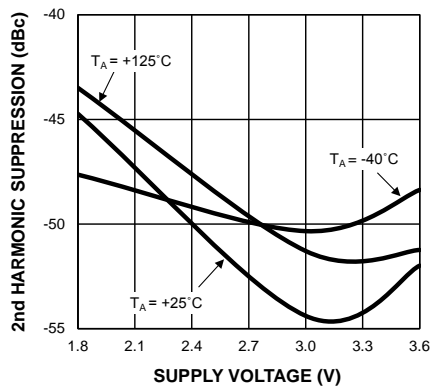

**3rd Harmonic vs. Supply Voltage**  
 $f_{RF} = 315MHz$ ,  $V_{ASK} = V_{DD}$

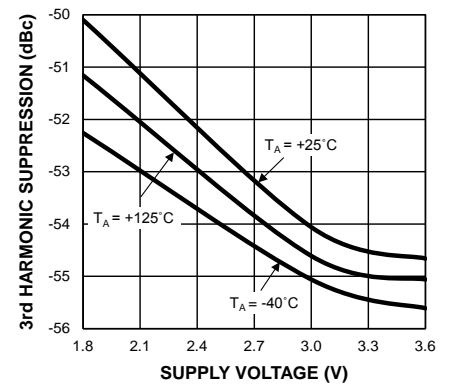

**Output Power and Supply Current vs.  $R_{BIAS}$**   
 $f_{RF} = 315MHz$ ,  $V_{ASK} = V_{DD}$

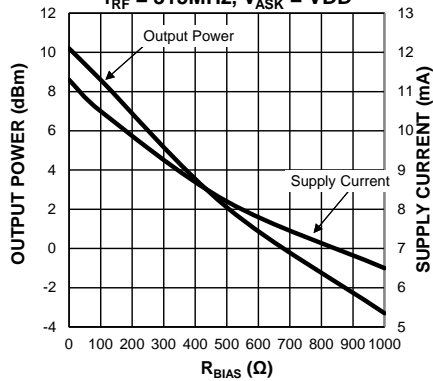

## Typical Characteristics (Continued)

**Supply Current vs. Supply Voltage**  
 $f_{RF} = 433.92\text{MHz}$ ,  $V_{ASK} = V_{DD}$

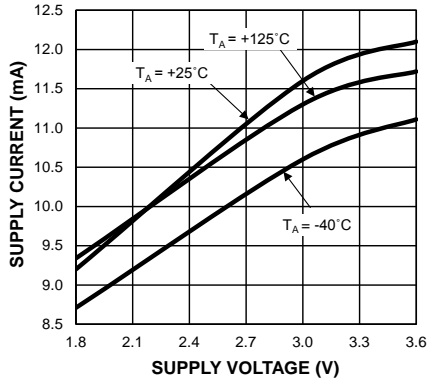

**Supply Current vs. Supply Voltage**  
 $f_{RF} = 433.92\text{MHz}$ ,  $V_{ASK} = GND$

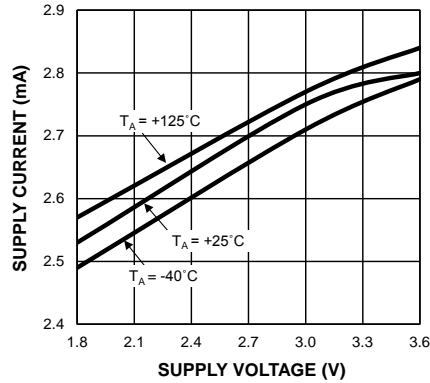

**Supply Current vs. Supply Voltage**  
 $f_{RF} = 433\text{MHz}$ ,  $V_{ASK} = 1\text{Kbps (50\%)}$

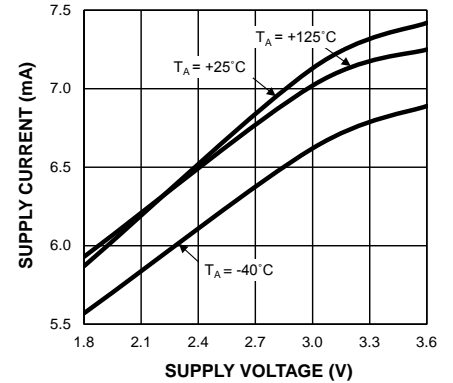

**Output Power vs. Supply Voltage**  
 $f_{RF} = 433.92\text{MHz}$ ,  $V_{ASK} = V_{DD}$

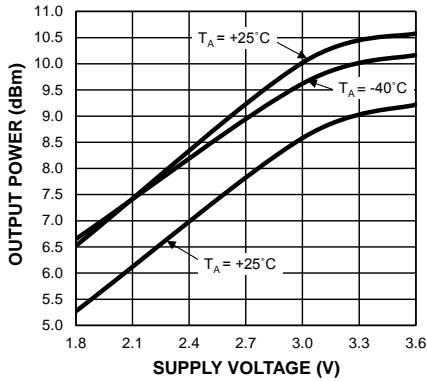

**2nd Harmonic vs. Supply Voltage**  
 $f_{RF} = 433\text{MHz}$ ,  $V_{ASK} = V_{DD}$

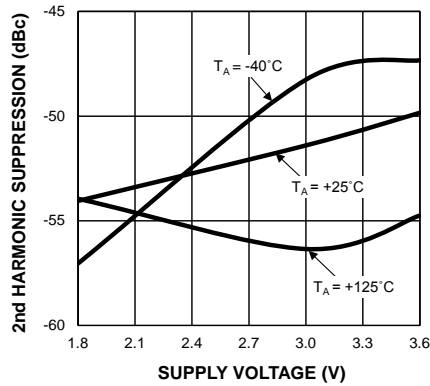

**3rd Harmonic vs. Supply Voltage**  
 $f_{RF} = 433.92\text{MHz}$ ,  $V_{ASK} = V_{DD}$

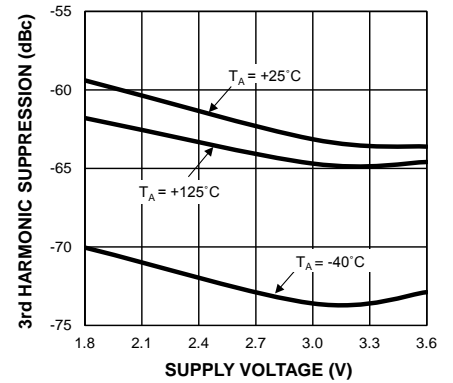

**Output Power and Supply Current vs.  $R_{BIAS}$**   
 $f_{RF} = 433.92\text{MHz}$ ,  $V_{ASK} = V_{DD}$  (Mark)

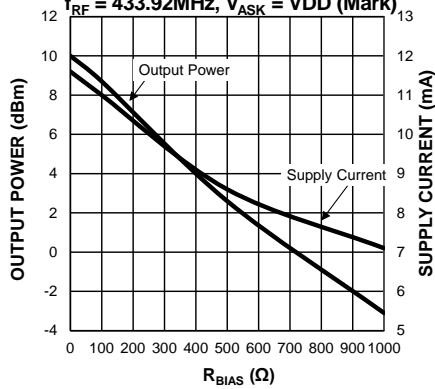

## Functional Diagram

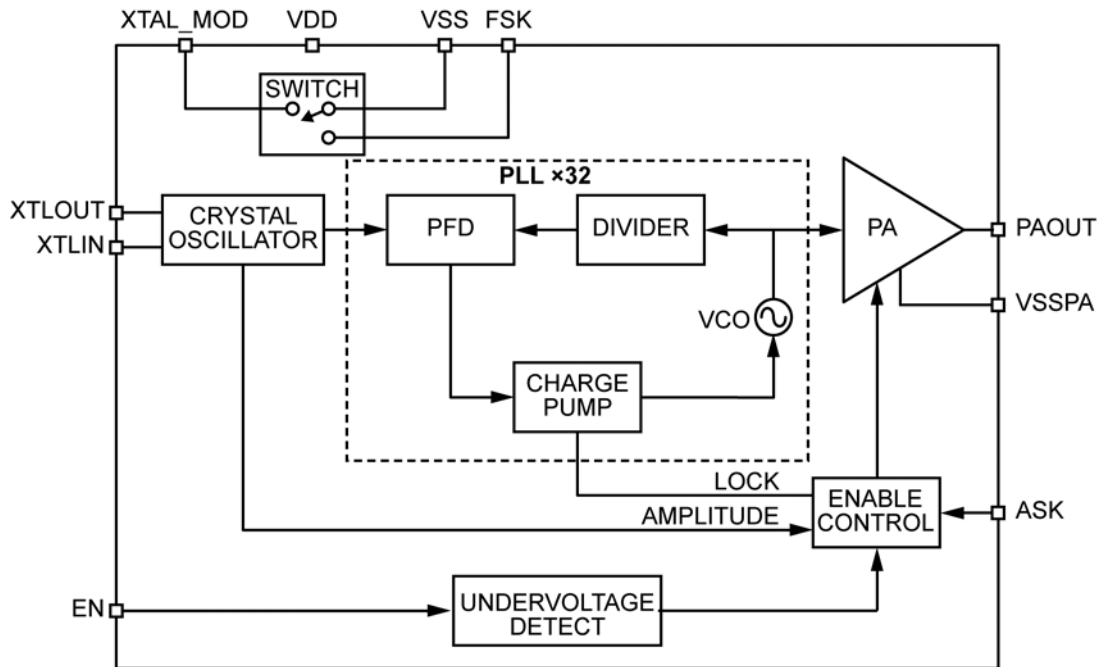

Figure 1. Functional Block Diagram MAQRF112

## Functional Description

The MAQRF112 is a 1.8V to 3.6V, 300MHz to 450MHz, +10dBm ASK/FSK transmitter. It has an integrated crystal oscillator, phase-locked loop (PLL), voltage-controlled oscillator (VCO), power amplifier (PA), undervoltage lockout (UVLO) and three logic-level inputs for ASK modulation/PA enable, FSK modulation, and on/off control. The device requires only a crystal, crystal loading capacitors, supply bypassing capacitors, and a few output matching components to match the PA to the load (loop antenna, 50Ω load, or whip antenna).

The device achieves ASK modulation using on and off modulation of the power amplifier. FSK modulation is achieved by pulling the crystal oscillator when an on-chip switch shunts an additional capacitance across the crystal.

The MAQRF112 is enabled or placed into a low-power shutdown mode through the logic-level EN input. An undervoltage lockout disables the PA until the power supply has reached a valid operating range. The only external components required are a crystal, antenna matching components, and power supply bypassing. Figure 1 shows the block diagram of the MAQRF112.

## Phase-Locked Loop (PLL) Synthesizer

The PLL of the MAQRF112 integrates a VCO, a “Divide-by-32” frequency divider, a phase-frequency detector (PFD), a charge pump, and a loop filter. The VCO tunes from 300MHz to 450MHz and drives both the PA and the divider. The divider divides the VCO frequency by 32, and the PFD compares the divided frequency against the reference frequency generated by the crystal oscillator. Any phase difference between these signals generates a current into the loop filter, which closes the loop with the VCO providing a precise, low phase-noise VCO, with quick start-up time. The PLL also includes an internal Lock indicator which will keep the PA disabled until the PLL has locked.

### Crystal Oscillator

The crystal oscillator provides a precision reference frequency to the PLL. The MAQRF112 uses a Pierce oscillator, which is operated in parallel resonant mode. It is designed to accept fundamental mode crystals, which operate from 9.375MHz to 14.0625MHz, to accommodate the “Divide-by-32” divider of the PLL. The crystal frequency is:

$$f_{XTAL} = f_{RF} \div 32 \quad \text{Eq. 1}$$

Most applications require an initial frequency tolerance of  $\pm 30\text{ppm}$  at  $T_A = +25^\circ\text{C}$  and an overtemperature stability of  $\pm 25\text{ppm}$  to  $\pm 50\text{ppm}$ , but that can vary depending on the desired operating temperature range and performance required versus crystal cost. The MAQRF112 Pierce oscillator can work with values of equivalent series resistance (ESR) in the range of  $5\Omega$  to  $300\Omega$ .

### ASK Crystal Oscillator Operation

Figure 2 shows a reference oscillator circuit configuration for ASK operation. The crystal is placed between the XTLIN (pin 2) and XTLOUT (pin 3). Table 1 shows corresponding ESR values to crystal parameter values.  $C_{PAR}$  is the parallel capacitance determined from internal crystal substrate contacts and board parasitic capacitance.

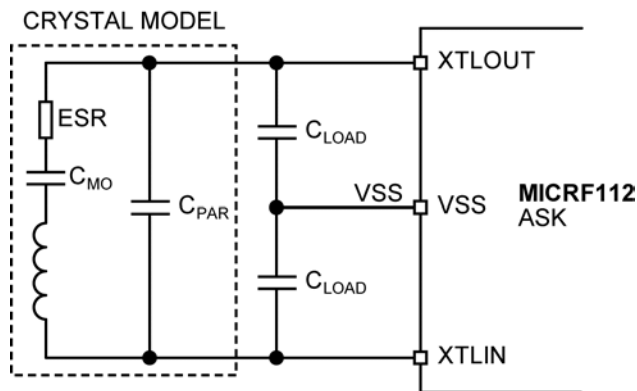

Figure 2. Reference Oscillator ASK Operation

ESR (Ω)	C <sub>PAR</sub> (pF)	C <sub>MO</sub> (fF)	C <sub>LOAD</sub> (pF)
20	1 to 10	10 to 40	10 to 70
300	1 to 5	10 to 40	10 to 30

Table 1. Recommended Crystal Oscillator Values

Referring to Figure 2, Equation 2 is an example of  $C_{L1}$  and  $C_{L2}$  calculation for a crystal load capacitance,  $C_{LOAD} = 10\text{pF}$ . The load capacitance seen by the crystal is calculated as follows:

$$C_{LOAD} = \frac{1}{\frac{1}{C_{L1}} + \frac{1}{C_{L2}}} + C_{STRAY} \quad \text{Eq. 2}$$

Therefore, the calculation of  $C_{L1}$  and  $C_{L2}$  for a specified  $C_{LOAD}$  of 10 pF is as follows:

$$C_{STRAY} = 1.5\text{pF} \text{ (stray pin and PCB capacitance)}$$

$$C_{L1} = C_{L2} = (C_{LOAD} - C_{STRAY}) \times 2$$

$$C_{L1} = C_{L2} = 18\text{pF}$$

The final value of  $C_{L1}$  and  $C_{L2}$  may need to be optimized on the bench because of board stray parasitics.

Capacitors,  $C_{L1}$  and  $C_{L2}$ , are placed from XTLIN to ground and from XTLOUT to ground. When specifying a crystal to a crystal manufacturer, the load capacitance,  $C_{LOAD}$ , must be specified as part of the manufacturing crystal design.

For ASK-only operation, connect the FSK pin to VSS and leave XTAL\_MOD unconnected.



**FSK Operation**

Figure 3 shows the reference oscillator circuit configuration for FSK operation. To operate the MAQRF112 device in FSK mode, one additional capacitor,  $C_{FSK}$ , is needed between the XTLOUT pin and the XTAL\_MOD pin. Crystal parameters for FSK operation are the same as for ASK operation except:

- When the ESR of the crystal is at 20Ω,  $C_{FSK} + C_{LOAD}$  must not exceed 70pF.
- When the ESR of the crystal is at 300Ω,  $C_{FSK} + C_{LOAD}$  must not exceed 30pF.

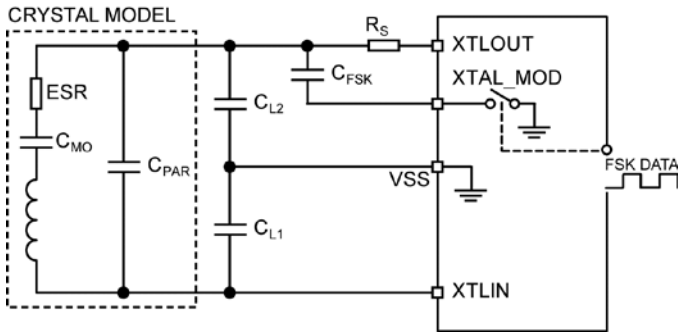

**Figure 3. Reference Oscillator FSK Operation**

**$C_{L1}$ ,  $C_{L2}$  and  $C_{FSK}$  Calculation**

Referring to Figure 3,  $C_{L1}$ ,  $C_{L2}$ , and  $C_{FSK}$  values depend on  $C_{LOAD}$ . Capacitor calculation is similar to ASK operation, with the addition of a shunt capacitor,  $C_{FSK}$ . Selection of  $C_{L1}$ ,  $C_{L2}$ , and  $C_{FSK}$  determine RF center frequency, high-side, and low-side RF frequency. See Figure 4.

Use Equation 3 to calculate the FSK high-side frequency calculation.

$$C_{LOAD} = \frac{1}{\frac{1}{C_{L1}} + \frac{1}{C_{L2}}} + C_{STRAY} \quad \text{Eq. 3}$$

Use Equation 4 to calculate the FSK low-side frequency calculation.

$$C_{LOAD} = \frac{1}{\frac{1}{C_{L1}} + \frac{1}{C_{L2} + C_{FSK}}} + C_{STRAY} \quad \text{Eq. 4}$$

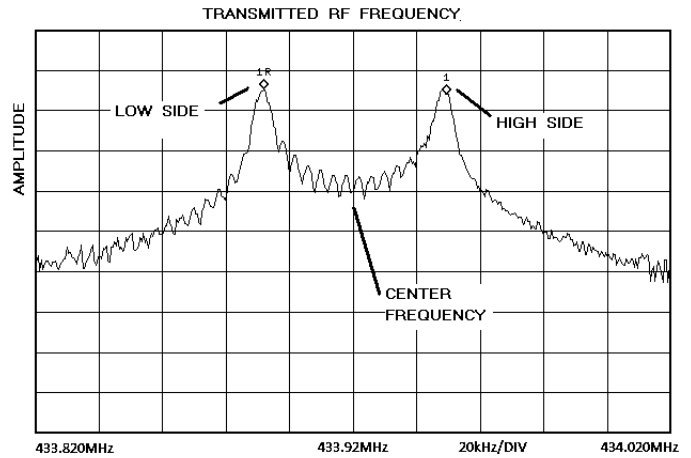

**Figure 4. MAQRF112 Frequency Deviation**

FSK modulation is achieved by pulling the crystal at the desired data rate. Pulling the crystal frequency is done by shunting  $C_{FSK}$  with  $C_{L2}$ . A logic-level LOW on the FSK data input opens the internal switch, removing  $C_{FSK}$ , which pulls the reference oscillator high. A logic-level HIGH closes the switch, paralleling the crystal  $C_{FSK}$  with  $C_{L2}$ , which pulls the reference frequency low. See Figure 4.  $R_S$  is used to minimize crystal RF spurs when using a low-quality crystal. A typical value of  $R_S$  is 0Ω to 1000Ω and depends on the crystal chosen. Board-level optimization is required to optimize for frequency deviation and occupied bandwidth requirements.

### Power Amplifier

The power amplifier serves two purposes: to buffer the VCO from external elements and to amplify the phase-locked signal. The power amplifier can produce +10dBm at 3V (typical). The PA output matching network to a 50Ω load or to a PCB antenna serves two purposes: to optimize PA output power and to minimize unwanted harmonics. Matching values are a function of operational frequency and load impedance seen by the MAQRF112. The “Application Information” section provides matching values for 315MHz and 433.92MHz.

### Power Control Using an External Resistor

A resistor (R7 on the 50Ω evaluation board) is in series with the output RF choke and can be used to adjust the RF output power and supply current. This adjustment can also be used to lower the power to meet FCC compliance. See the “Output Power and Supply Current vs.  $R_{BIAS}$ ” graphs in the “Typical Characteristics” section for examples of performance on the 50Ω evaluation boards. An evaluation board using a PCB antenna can have its radiated power lowered by adjusting this series resistor. The resistor value must be calibrated empirically, and will vary depending on the final product PCB layout and form factor.

### Enable Control

The Enable control gates the ASK data to the PA. It allows transmission only when the lock, crystal amplitude, and undervoltage detect conditions are valid. An Enable and ASK logic-level HIGH places the PA in the Mark condition. An Enable logic-level LOW disables the power amplifier. An Enable logic-level HIGH and an ASK logic-level LOW places the PA in the Space condition. To transmit with FSK modulation, both the EN and ASK pins must be set to a logic-level HIGH while the FSK pin is digitally modulated with a logic-level signal.

### ASK Input Control

An ASK logic-level data input modulates the RF carrier when the PA is enabled. Apply a data stream less than 50Kbps (Manchester Encoded, 50% duty-cycle) for ASK modulation. Tying the FSK pin low is recommended when ASK modulation is used.

### Undervoltage Detect

The undervoltage detect block senses the operating voltage. If the operating voltage falls below 1.6V, the undervoltage detect block sends a signal to the enable control block to disable the PA.

## Application Information

The MAQRF112 is ideal for driving a 50Ω load monopole or a PCB loop antenna. The following sections discuss PCB loop antenna and 50Ω output configurations.

### Output Matching Network

Part of the function of the output network is to attenuate the second and third harmonics. When matching to a transmit frequency, take care not only to optimize for maximum output power but to attenuate unwanted harmonics. Proper matching to a PCB antenna or a 50Ω load optimizes current requirements.

### Layout Issues

PCB layout is extremely important to achieve optimum performance and consistent manufacturing results. Be careful with the orientation of the components to ensure that they do not couple or decouple the RF signal. PCB trace length should be short, to minimize parasitic inductance (1in ~ 20nH). For example, depending on inductance values, a 0.5in trace can change the inductance by as much as 10%. To reduce parasitic inductance, the use of wide traces and a ground plane under signal traces is recommended. Use vias with low inductance values for components requiring a connection to ground.

### Crystal PCB Layout

Crystal PCB board layout affects the calculated frequency deviation. It is recommended that the crystal be located close to the XTLIN and XTLOUT pins to minimize trace lengths. Trace thickness should be no greater than 20mil.

### Antenna Layout

The antenna trace layout affects directivity. No ground plane should be under the antenna trace. For consistent performance, do not place components inside the loop of the antenna. Gerbers for a suggested layout are available on the Micrel website at: [www.micrel.com](http://www.micrel.com).

### ASK PCB Loop Antenna Application Circuit

Figure 5 is an example of an ASK circuit configuration using a PCB loop antenna. Table 2 lists modified values for both 315MHz and 433.92MHz configurations, including crystal values for 315MHz and 433.92MHz operation. Values are dependent on PCB board layout. Refer to the Micrel website for a reference design and PCB Gerber files.

Frequency (MHz)	L1 (nH)	C5 (pF)	L4 (nH)	C7 (pF)	Y1 (MHz)
315	470	10	150	4.7	9.84375
433.92	680	10	82	3.9	13.5600

Table 2. PCB Antenna Matching Network

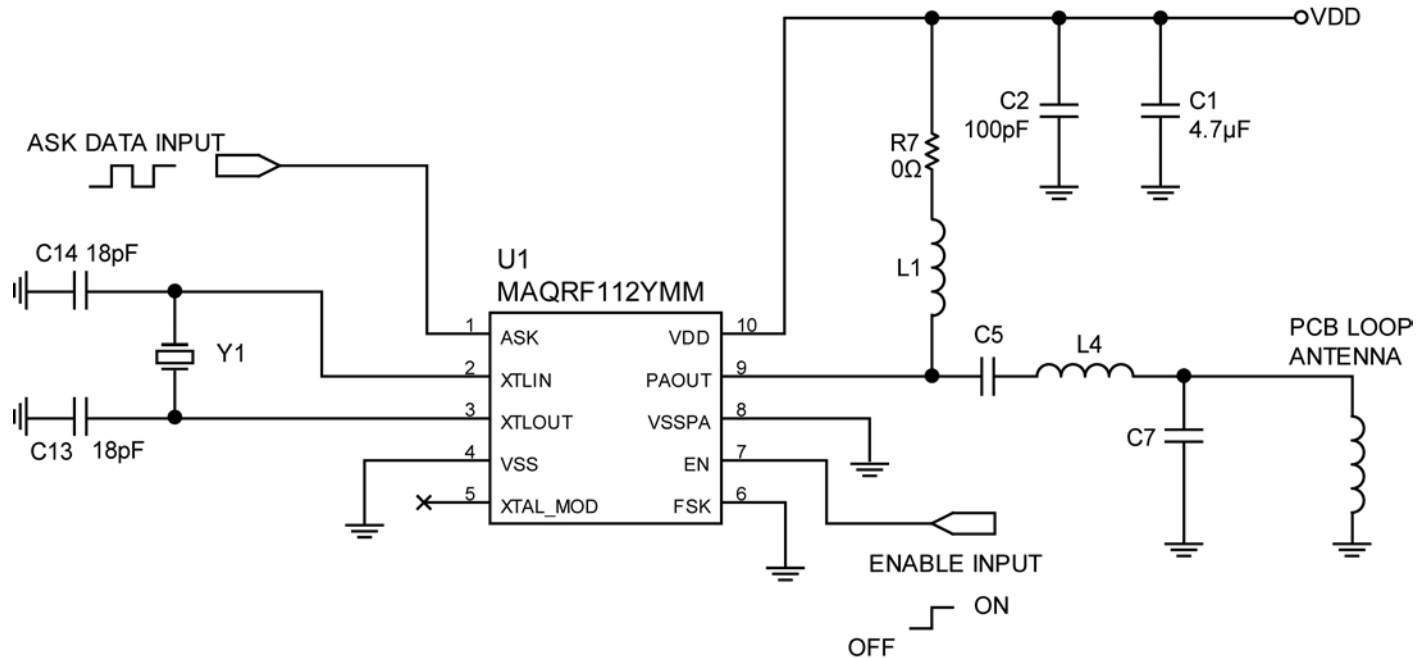

Figure 5. MAQRF112 ASK Application Circuit with PCB Loop Antenna

**FSK PCB Loop Antenna Application Circuit**

Figure 6 is an example of a FSK circuit configuration using a PCB loop antenna. Table 3 lists modified values for both 315MHz and 433.92MHz configurations, including crystal values for 315MHz and 433.92MHz operation. Antenna matching values are dependent on PCB board layout. Refer to the Micrel website for a reference design and PCB Gerber files. Table 4 lists crystal capacitor load values for a frequency deviation of  $\pm 25$ kHz. For crystal capacitor calculations, refer to the "FSK Operation" section.

Frequency (MHz)	L1 (nH)	C5 (pF)	L4 (nH)	C7 (pF)	Y1 (MHz)
315	470	10	150	4.7	9.84375 <sup>(1)</sup>
433.92	680	10	82	3.9	13.5600 <sup>(2)</sup>

**Table 3. PCB Antenna Matching Network**

**Notes:**

1. Y1 = Abracon ABL5-9.84375MHz-10-R50-K4Q for 315MHz
2. Y1 = Abracon ABL5-13.5600MHz-10-R50-K4Q for 433.92MHz

Center Frequency (MHz)	C14 (pF)	C13 (pF)	C8 (pF)	Frequency Deviation (kHz)
315	15	10	22	$\pm 25$
433.92	18	6.8	15	$\pm 25$

**Table 4. Crystal Capacitor Values for FSK Operation**

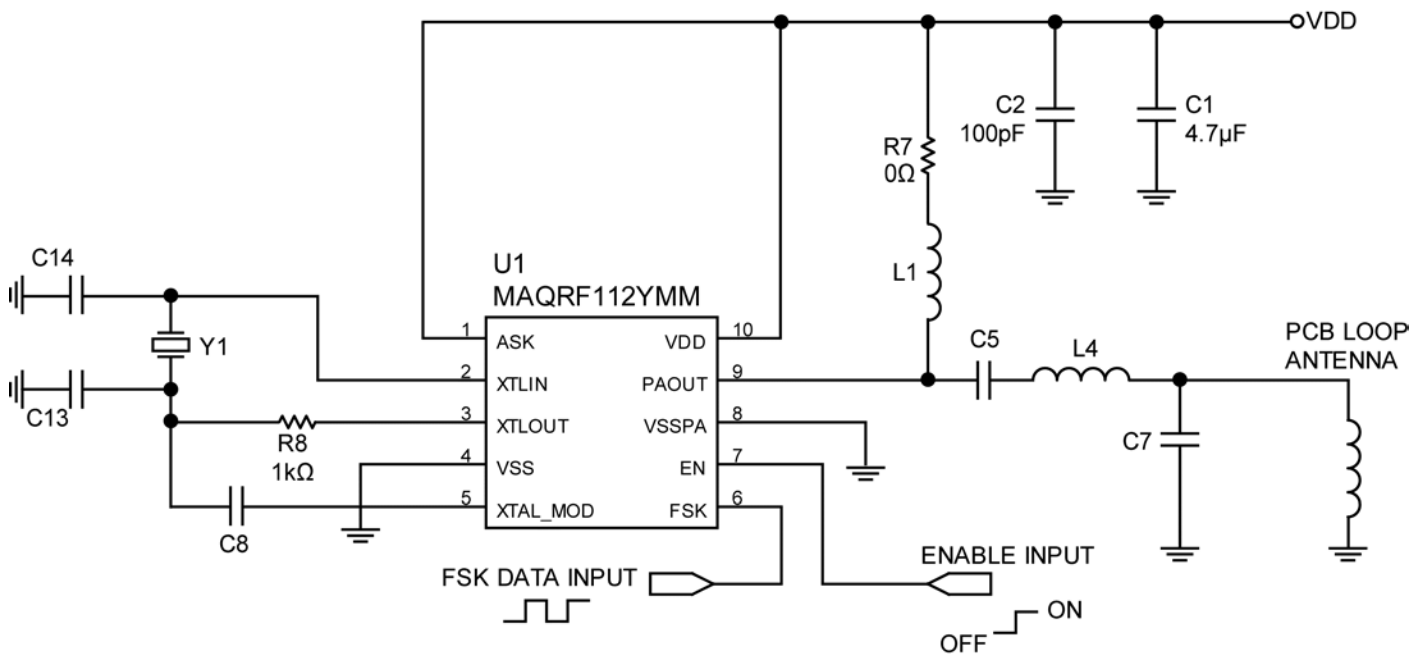

**Figure 6. MAQRF112 FSK Application Circuit with PCB Loop Antenna**

**ASK 50Ω Load Application Circuit**

Figure 7 is an example of an ASK circuit configuration used to drive a 50Ω load. Table 5 lists modified values for both 315MHz and 433.92MHz configurations, including crystal values for 315MHz and 433.92MHz operation. The matching network values are dependent on PCB board layout. Refer to the Micrel website for a reference design and the PCB Gerber files

Frequency (MHz)	L1 (nH)	C5 (pF)	L2 (nH)	C7 (pF)	C11 (pF)	Y1 (MHz)
315	470	8.2	82	8.2	2.2	9.84375
433.92	470	2.2	82	6.8	1.2	13.5600

**Table 5. 50Ω Load Matching Network**

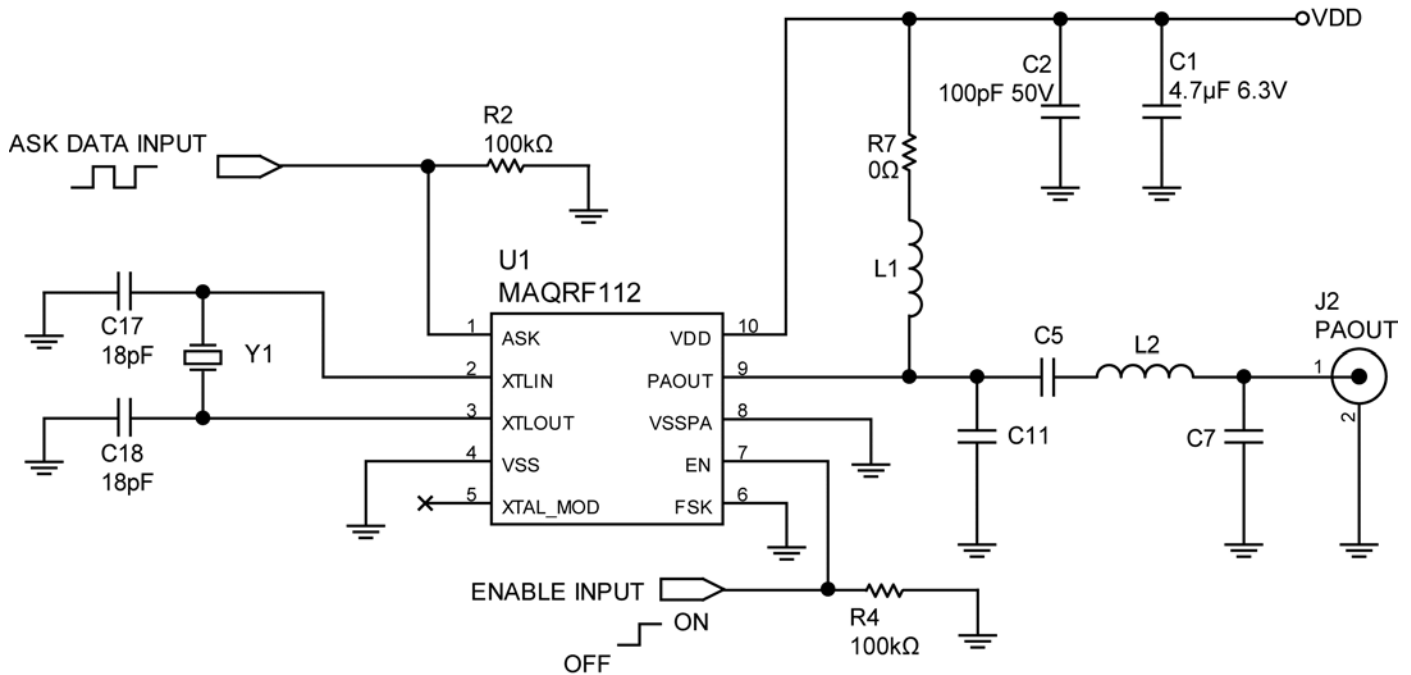

**Figure 7. MAQRF112 ASK 50Ω Evaluation Board**

**FSK- 50Ω Load Application Circuit**

Figure 8 is an example of a FSK circuit configuration used to drive a 50Ω load. Table 6 lists modified values for both 315MHz and 433.92MHz configurations, including crystal values for 315MHz and 433.92MHz operation. The matching network values are dependent on PCB board layout. Refer to the Micrel website for a reference design and PCB Gerber files. Table 7 lists crystal capacitor load values for a frequency deviation of ±25 kHz. For crystal capacitor calculations, refer to the “FSK Operation” section.

Frequency (MHz)	L1 (nH)	C5 (pF)	L2 (nH)	C7 (pF)	C11 (pF)	Y1 (MHz)
315	470	8.2	82	8.2	2.2	9.84375 <sup>(1)</sup>
433.92	470	2.2	82	6.8	1.2	13.5600 <sup>(2)</sup>

**Table 6. 50Ω Load Matching Network**

**Notes:**

1. Y1 = Abracon ABLS-9.84375MHz-10-R50-K4Q for 315MHz
2. Y1 = Abracon ABLS-13.5600MHz-10-R50-K4Q for 433.92MHz

Center Frequency (MHz)	C17 (pF)	C18 (pF)	C9 (pF)	Frequency Deviation (kHz)
315	15	10	22	±25
433.92	18	6.8	15	±25

**Table 7. 50Ω Load Matching Network**

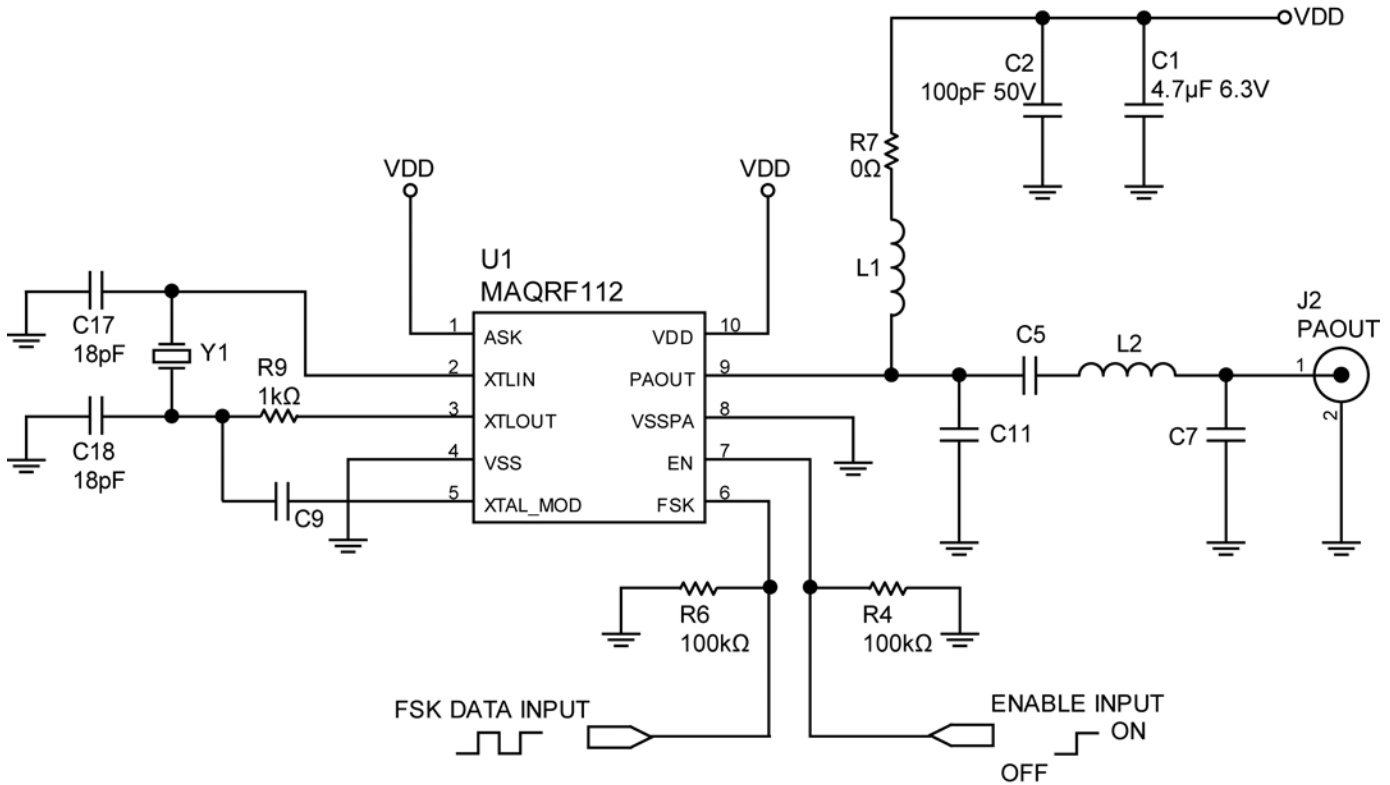

**Figure 8. MAQRF112 FSK 50Ω Evaluation Board**

Package Information<sup>(1)</sup>

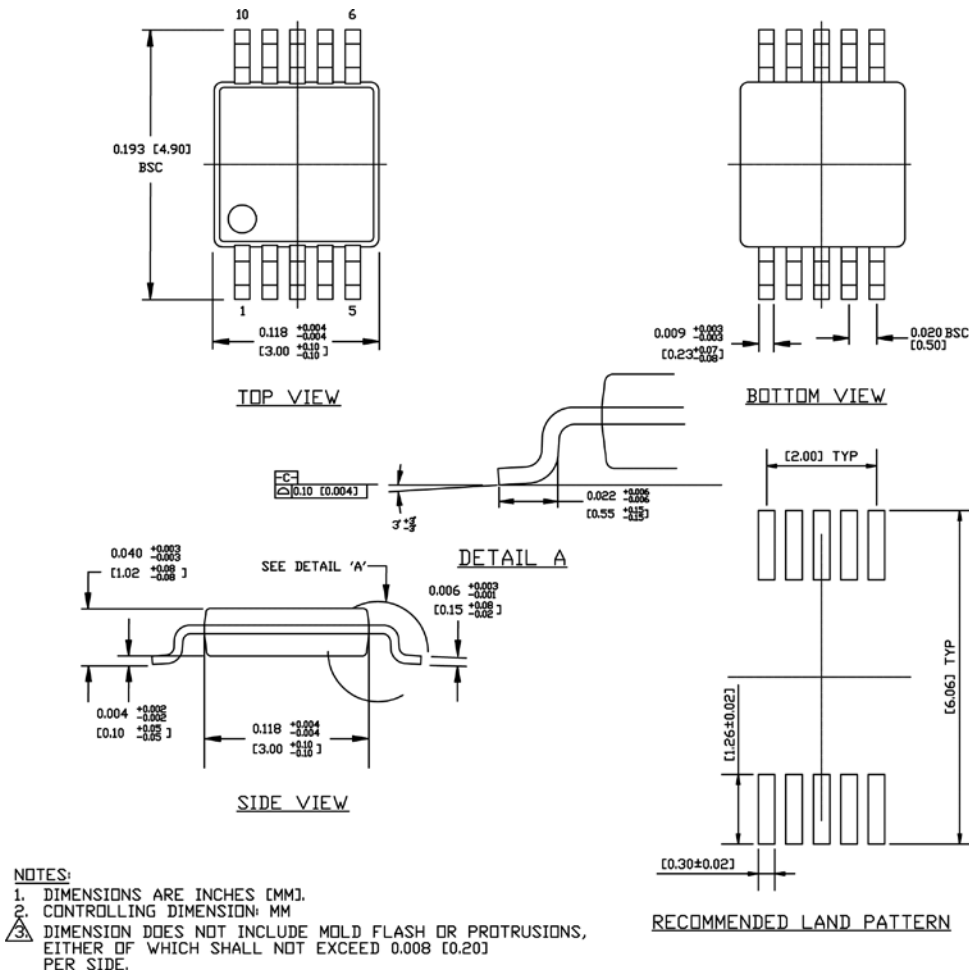

10-Pin MSOP Package Type (YMM)

Note:

- Package information is correct as of the publication date. For updates and most current information, go to [www.micrel.com](http://www.micrel.com).

**MICREL, INC. 2180 FORTUNE DRIVE SAN JOSE, CA 95131 USA**  
 TEL +1 (408) 944-0800 FAX +1 (408) 474-1000 WEB <http://www.micrel.com>

Micrel makes no representations or warranties with respect to the accuracy or completeness of the information furnished in this datasheet. This information is not intended as a warranty and Micrel does not assume responsibility for its use. Micrel reserves the right to change circuitry, specifications and descriptions at any time without notice. No license, whether express, implied, arising by estoppel or otherwise, to any intellectual property rights is granted by this document. Except as provided in Micrel's terms and conditions of sale for such products, Micrel assumes no liability whatsoever, and Micrel disclaims any express or implied warranty relating to the sale and/or use of Micrel products including liability or warranties relating to fitness for a particular purpose, merchantability, or infringement of any patent, copyright or other intellectual property right.

Micrel Products are not designed or authorized for use as components in life support appliances, devices or systems where malfunction of a product can reasonably be expected to result in personal injury. Life support devices or systems are devices or systems that (a) are intended for surgical implant into the body or (b) support or sustain life, and whose failure to perform can be reasonably expected to result in a significant injury to the user. A Purchaser's use or sale of Micrel Products for use in life support appliances, devices or systems is a Purchaser's own risk and Purchaser agrees to fully indemnify Micrel for any damages resulting from such use or sale.



Компания «ЭлектроПласт» предлагает заключение долгосрочных отношений при поставках импортных электронных компонентов на взаимовыгодных условиях!

Наши преимущества:

- Оперативные поставки широкого спектра электронных компонентов отечественного и импортного производства напрямую от производителей и с крупнейших мировых складов;
- Поставка более 17-ти миллионов наименований электронных компонентов;
- Поставка сложных, дефицитных, либо снятых с производства позиций;
- Оперативные сроки поставки под заказ (от 5 рабочих дней);
- Экспресс доставка в любую точку России;
- Техническая поддержка проекта, помощь в подборе аналогов, поставка прототипов;
- Система менеджмента качества сертифицирована по Международному стандарту ISO 9001;
- Лицензия ФСБ на осуществление работ с использованием сведений, составляющих государственную тайну;
- Поставка специализированных компонентов (Xilinx, Altera, Analog Devices, Intersil, Interpoint, Microsemi, Aeroflex, Peregrine, Syfer, Eurofarad, Texas Instrument, Miteq, Cobham, E2V, MA-COM, Hittite, Mini-Circuits, General Dynamics и др.);

Помимо этого, одним из направлений компании «ЭлектроПласт» является направление «Источники питания». Мы предлагаем Вам помощь Конструкторского отдела:

- Подбор оптимального решения, техническое обоснование при выборе компонента;
- Подбор аналогов;
- Консультации по применению компонента;
- Поставка образцов и прототипов;
- Техническая поддержка проекта;
- Защита от снятия компонента с производства.



#### Как с нами связаться

**Телефон:** 8 (812) 309 58 32 (многоканальный)

**Факс:** 8 (812) 320-02-42

**Электронная почта:** [org@eplast1.ru](mailto:org@eplast1.ru)

**Адрес:** 198099, г. Санкт-Петербург, ул. Калинина, дом 2, корпус 4, литера А.