

AGASTAT EGP/EML/ETR Series, Nuclear Qualified Control Relays



Seismic and Radiation Tested

In order to satisfy the need for electrical control components suitable for class 1E service in nuclear power generating stations, AGASTAT control relays have been tested for these applications. Series EGP, EML and ETR have demonstrated compliance with the requirements of IEEE Standards 323-1974 (Standard for

qualifying Class 1E Equipment for Nuclear Power Generating Stations) and IEEE Standard 344-1975 (Seismic Qualification for Nuclear Power Generating Stations). Testing was also referenced to ANSI/IEEE C37.98 (formerly IEEE Standard 501-1978, Standard for Seismic Testing of Relays).

The design of Series EGP, EML and ETR control relays has evolved over 20 years of continual use in a wide range of industrial applications. Control Relay, Magnetic Latch and Timing Relay versions are available for use with a choice of coil voltages, as well as an internal fixed or adjustable potentiometer in the Series ETR time delay version.

Test Procedure

Test Procedure

AGASTAT control relay Series EGP, EML and ETR were tested in accordance with the requirements of IEEE STD. 323-1974 (Standard for Qualifying Class 1E Equipment for Nuclear Power Generating Stations), IEEE STD. 344-1975 (Seismic Qualification for Nuclear Power Generating Stations) and referenced to ANSI/IEEE C37.98 (formerly IEEE Standard 501-1978, Standard for Seismic Testing of Relays). The relays were tested according to parameters which in practice, should encompass the majority of applications. Documented data applies to relays which were mounted on rigid test fixtures. The following descriptions of the tests performed are presented in their actual sequence.

Baseline Performance

In addition to aging tests, a series of baseline tests were conducted before, and immediately after each aging sequence:

- Pull-in Voltage
- Drop-out Voltage
- Dielectric Strength at 1650V 60Hz
- Insulation Resistance
- Operate Time (milliseconds)

- Recycle Time (milliseconds)
- Time Delay (seconds) } Series ETR
- Repeatability (percent) } only
- Contact Bounce
- (milliseconds at 28VDC, 1 amp)
- Contact Resistance
- (milliohms at 28VDC, 1 amp)

Data was measured and recorded and used for comparison throughout the qualification test program in order to detect any degradation of performance.

Radiation Aging

Relays were subjected to a radiation dosage of 2.0×10^5 Rads, which is considered to exceed adverse plant operating requirements for such areas as auxiliary and control buildings.

Cycling with Load Aging

The radiated units were then subjected to 27,500 operations at accelerated rate, with one set of contacts loaded to 120VAC, 60Hz at 10 amps; or 125VDC at 1 amp, and the number of mechanical operations exceeding those experienced in actual service.

Temperature Aging

This test subjected the relays to a temperature of 100°C for 42 days, with performance measured before and after thermal stress.

Seismic Aging

Sufficient interactions were performed at levels less than the fragility levels of the devices in order to satisfy the seismic aging requirements of IEEE STD 323-1974 and IEEE STD 344-1975.

Seismic Qualification

Artificially aged relays were subjected to simulated seismic vibration, which verified the ability of the individual device to perform its required function before, during and/or following design basis earthquakes. Relays were tested in the non-operating, operating and transitional modes.

Hostile Environment

Since the timing relays are intended for use in auxiliary and control buildings, and not in the reactor containment areas, a hostile environment test was performed in place of the Loss of Coolant Accident (LOCA) test. Relays were subjected to combination extreme temperature/humidity plus under/over voltage testing to prove their ability to function under adverse conditions even after having undergone all the previous aging simulation and seismic testing. The devices were operated at minimum and maximum voltage extremes: 85 and 120 percent of rated voltage for AC units, and 80 and 120 percent of rated voltage for DC units, with temperatures ranging from 40°F to 172°F at 95 percent relative humidity.

12
Specialty Relays

The SRS shape (at 5 percent damping), is defined by four points:

- point A = 1.0 Hz and an acceleration equal to 25 percent of the Zero Period Acceleration (ZPA)
- point D = 4.0 Hz and 250 percent of the ZPA
- point E = 16.0 Hz and 250 percent of the ZPA
- point G = 33.0 Hz and a level equal to the ZPA

Specimen 13, 15 & 16 (EGP Series)
Relay State: Non-Operate Mode (De-ener.)
Test Run No. 318, 319, (205-206), (198-199)
Axis (H + V):
Composite of FB/V-, SS/V, FB/V+ X .707
Due to 45° inclination of test machine.

Additional Seismic Response Curves are available on request.

Relay State: Non-Operate Mode (De-ener.)
Test Run No. 318, 319, (205-206), (198-199)

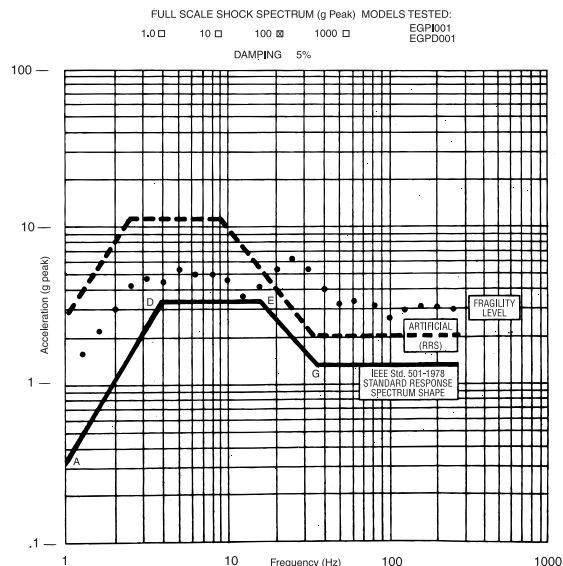

Figure 1. Model EGP, Response Spectrum, Non-Operate Mode

AGASTAT EGP/EML/ETR Series, Nuclear Qualified Control Relays (Continued)

Operation

Series EGP Power Relay

Applying a voltage to the coil (B1-B4) for more than 50 msec energizes the coil and instantaneously transfers the switch, breaking the normally closed contacts (M1-R1, M2-R2, M3-R3, M4-R4) and making the normally open contacts (M1-T1, M2-T2, M3-T3, M4-T4). The contacts remain in this transferred position until the coil is deenergized, at which time the switch instantaneously returns the contacts to their original position.

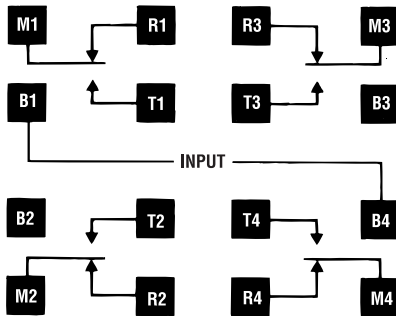

Series EML Magnetic Latch

Application of a voltage to the latching input (B1-B4) will cause the relay to latch in (Make the N.O. Contacts, break the N.C. Contacts). When this voltage is removed, the relay will remain in this "Latched" condition. Application of a voltage to the unlatching input (B3-B4) will cause the relay to dropout (Break the N.O. Contacts, make the N.C. Contacts). When this voltage is removed, the relay will remain in this "Unlatched" condition.

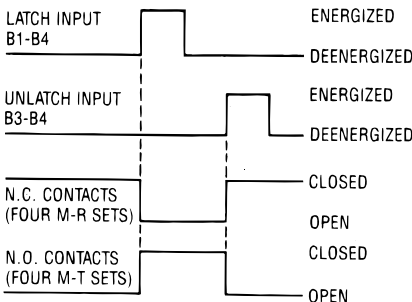

Wiring Diagram (Wiring and Connections)

The ML relay has three terminals for the windings: latching winding between terminals B1 and B4, un-latching winding between terminals B3 and B4.

The ML Relay is not symmetrical due to its three coil connections.

The relays are normally delivered polarized so that terminal B4 carries the negative voltage. To reverse the polarity, a deenergize/energize cycle should be carried out using a voltage 50% greater than the normal rating.

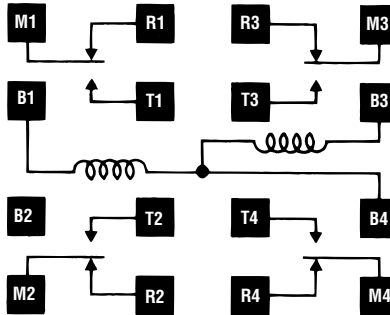

Continuous Duty Wiring

Since the double wound coil does not have a continuous duty rating, voltage pulses to the coils should not exceed a ratio of 40% on, to 60% off, with maximum power-on periods not to exceed 10 minutes.

If continuous energizing only is available, a resistor/capacitor network should be connected as shown below. In this case the shortest time between two operations must not be less than 5 seconds.

The relay will always assume the energized position in the event of both windings being energized simultaneously.

It is advisable not to put another load in parallel with the windings of the ML relay.

ML Series Relay for DC Operation with a Resistor/Capacitor Network

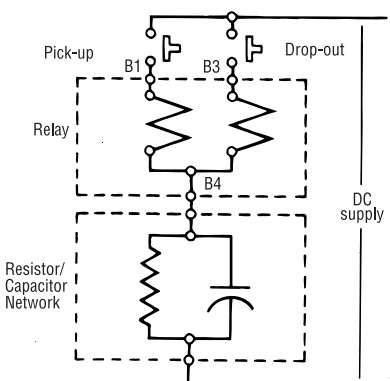

R-C Values

Nominal Voltage VDC	R		C	
	Ohms ±5%	Watts	UF	VDC
12	62	2	5000	15
24	240	2	2000	50
48	1000	2	500	100
125	6200	2	150	150

Series ETR Time Delay Relay (Delay on Energization)

Applying a voltage to the input terminals (B1-B4) for more than 50 msec starts a time delay lasting for the preset time period. During this period the normally closed contacts (Four M-R sets) remain closed. At the end of the delay period, the normally closed contacts break and the normally open contacts (Four M-T sets) make. The contacts remain in this position until the relay is deenergized, at which time the contacts instantaneously return to their normal position. Deenergizing the relay, either during or after the delay period will recycle the unit within .075 second. It will then provide a full delay period upon reenergization, regardless of how often the voltage is interrupted before the unit has been permitted to "time-out" to its full delay setting.

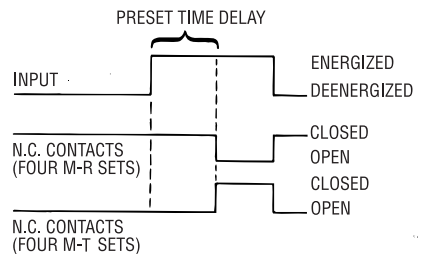
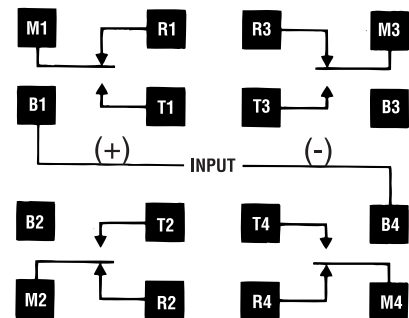

AGASTAT EGP/EML/ETR Series, Nuclear Qualified Control Relays (Continued)



Specifications

Contact Ratings —

Series EGP/EML/ETR —

Contact Capacity in Amperes (Resistive)

Contact Voltage	Min. 1,000,000 Operations
24 Vdc	10.0 Amps
125 Vdc	1.0 Amp
120 Vac, 60 Hz	10.0 Amps
240 Vac, 60 Hz	7.5 Amps

Contact Ratings, UL —

Series EGP/EML Only —

Contact ratings as Listed under the Underwriters Laboratory Component Recognition Program. (Two poles per load):

- 1/3 Horsepower, 120 Vac
- 10 Amps, General Purpose, 240 Vac
- 120 Vdc, 1.0 Amp

Mechanical Life —

Series EGP/EML/ETR —

25,000 mechanical operations

Approximate Weight —

Series EGP/EML/ETR —

1 lb.

Transient Protection —

Series ETR Only — A 1500 volt transient of less than 100 microseconds, or 1000 volts of less than 1 millisecond will not affect timing accuracy

Timing Adjustment —

Series ETR Only —

Internal Fixed
Internal Potentiometer

Time Ranges — Series ETR Only —

- A — .15 to 3 sec.
- B — .55 to 15 sec.
- C — 1 to 30 sec.
- D — 2 to 60 sec.
- E — 4 to 120 sec.
- G — 10 to 300 sec.
- I — 2 to 60 min.
- N — 1 to 30 min.

Repeat Accuracy —

Series ETR Only —

The repeat accuracy deviation (A_R) of a time-delay relay is a measure of the maximum deviation in the time-delay that will be experienced in five successive operations at any particular time setting of the relay and over the operating voltage and temperature range specified. Repeat accuracy is obtained from the following formula:

$$A_R = \pm 100 \frac{(T_1 - T_2)}{(T_1 + T_2)}$$

Where —

- T_1 = Maximum Time Delay
- T_2 = Minimum Time Delay

The date of manufacture can be found in the first four (4) digits of the serial number on the nameplate:

First two digits indicate the year XX XX

Second two digits indicate the week.

Example: In the date code 7814 below: "78" indicates the year 1978; "14" indicates the 14th week (or April 3 through April 7).

Model	
Coil	125 VDC
Serial	78140028

Note: TE Corporation does not recommend the use of its products in the containment areas of Nuclear Power Generating Stations.

REPLACEMENT SCHEDULE
Series EGP/EML/ETR
The qualified life of these relays is 25,000 electrical operations or 10 years from the date of manufacture, whichever occurs first.

AGASTAT EGP/EML/ETR Series, Nuclear Qualified Control Relays (Continued)

Operating Characteristics

Environmental Conditions (Qualified Life) — Series EGP/EML/ETR

Parameter	Min.	Normal	Max.
Temperature (°F)	40	70-104	156
Humidity (R.H. %)	10	40-60	95
Pressure	—	Atmospheric	—
Radiation (rads)	—	—	2.0 x 10 ⁵ (Gamma)

Operating Conditions, Normal Environment – Series EGP/EML/ETR

Normal Operating Specifications	With DC Coils			With AC Coils	
	EGP	EML	ETR	EGP	ETR
Coil Operating Voltage, Nominal (rated)*	As Spec.	As Spec.	As Spec.	As Spec.	As Spec.
Pull-in (% of rated value)	80% Min.	85% Min.	80% Min.	85% Min.	85% Min.
Drop-out (% of rated value)	5-45%	85% Min.	5-45%	5-45%	5-50%
Continuous (% of rated value)	110% Max.	N/A	110% Max.	110% Max.	110% Max.
Power (Watts at rated value)					
Pull-in	6 Apprx.	15 Apprx.	6 Apprx.	6 Apprx.	6 Apprx.
Drop-out	N/A	13 Apprx.	N/A	N/A	N/A
Relay Operate Time	30 ms Max.	25 ms Max. With min. latch pulse of 30 ms.	N/A	35 ms Max.	N/A
Relay Release (Recycle) Time	25 ms Max.	20 ms Max. With min. latch pulse of 30 ms.	75 ms Max.	85 ms Max.	75 ms Max.
Contact Ratings, Continuous					
Resistive at 125 vdc	1.0 amp.	1.0 amp.	1.0 amp.	1.0 amp.	1.0 amp.
Resistive at 120 vac, 60 Hz	10.0 amp.	10.0 amp.	10.0 amp.	10.0 amp.	10.0 amp.
Insulation Resistance (In megohms at 500 vdc)	500 Min.	500 Min.	500 Min.	500 Min.	500 Min.
Dielectric (vrms, 60 Hz)					
Between Terminals and Ground	1,500	1,500	1,500	1,500	1,500
Between Non-connected Terminals	1,500	1,500	1,500	1,500	1,500
Repeat Accuracy	N/A	N/A	±5%	N/A	±5%

Operating Conditions, Abnormal Environment – Series EGP/EML

Adverse Operating Specifications	Normal	DB "A"	DB "B"	DB "C"	DB "D"
Temperature (°F)	70-104	40	120	145	156
Humidity (R.H. %)	40-60	10-95	10-95	10-95	10-95
Coil Operating Voltage (% of rated)*					
AC (Series EGP only)	85-110	85-110	85-110	85-110	85-110
DC (Series EGP only)	80-110	80-110	80-110	80-110	80-110
DC (Series EML only)	85-110	85-110	85-110	85-110	85-110
Relay Operate Time (ms)					
AC (Series EGP only)	35 Max.	35 Max.	35 Max.	35 Max.	35 Max.
DC (Series EGP, Series EML)	30 Max.	25 Max.	37 Max.	40 Max.	40 Max.

Operating Conditions, Abnormal Environment – Series ETR

Adverse Operating Specifications	With DC Coils	With AC Coils
Coil Operating Voltage (rated)*	As Spec.	As Spec.
Pull-in (% of rated value)	80% Min.	85% Min.
Continuous (% of rated value)	110% Max.	110% Max.
Drop-out (% of rated value)	5-45%	5-50%
Power (Watts at rated value)	6 Apprx.	6 Apprx.
Relay Release (Recycle) Time	75 ms Max.	75 ms Max.
Contact Ratings, Continuous		
Resistive at 125 vdc	1.0 amp.	1.0 amp.
Resistive at 120 vac, 60 Hz	10.0 amp.	10.0 amp.
Repeat Accuracy	±10%	±10%

*All coils may be operated on intermittent duty cycles at voltages 10% above listed maximums (Intermittent Duty = Maximum 50% duty cycle and 30 minutes "ON" time.)

AGASTAT EGP/EML/ETR Series, Nuclear Qualified Control Relays (Continued)

Dimensions and Mounting

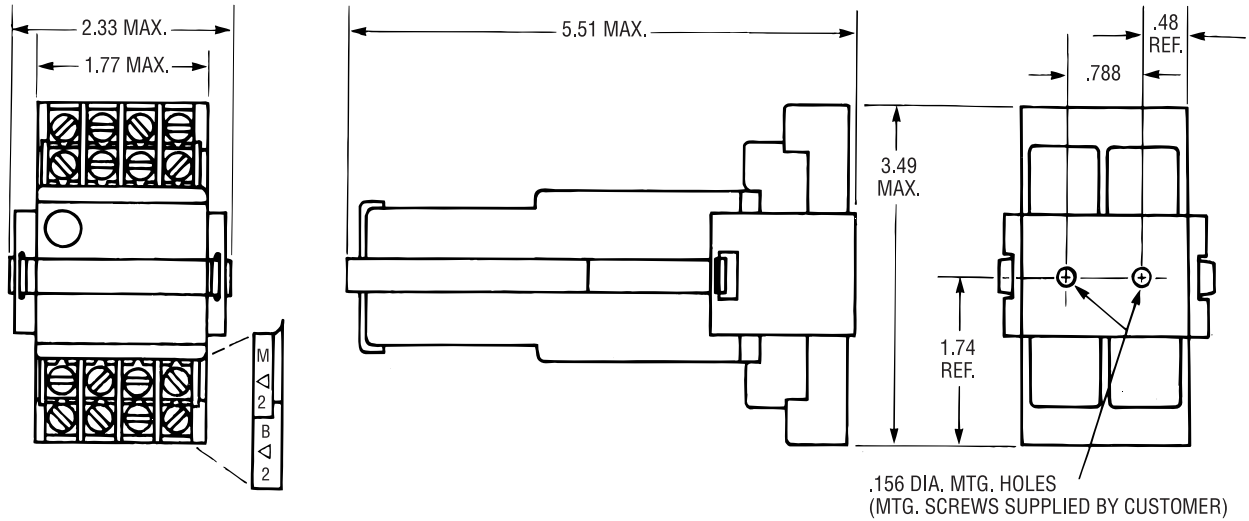

Qualification tested in the horizontal position, mounted in socket ECR0001-001 (captive clamp terminals) or in socket ECR0002-001 (screw terminals) with locking straps ECR0133.

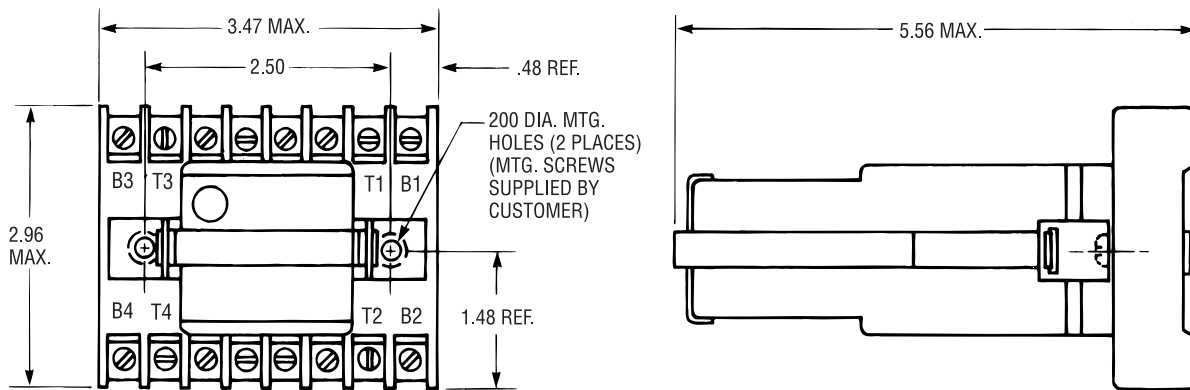

Qualification tested in the horizontal position, mounted in socket ECR0095-001 (screw terminals) with locking strap ECR0155.

Series EGP, EML and ETR AGASTAT control relays must be mounted in the horizontal position; performance specifications of these units are valid only when they are mounted as indicated in either of the above drawings. All dimensions in inches.

AGASTAT EGP/EML/ETR Series, Nuclear Qualified Control Relays (Continued)

Ordering Information

Catalog Number Code — Series EGP and EML

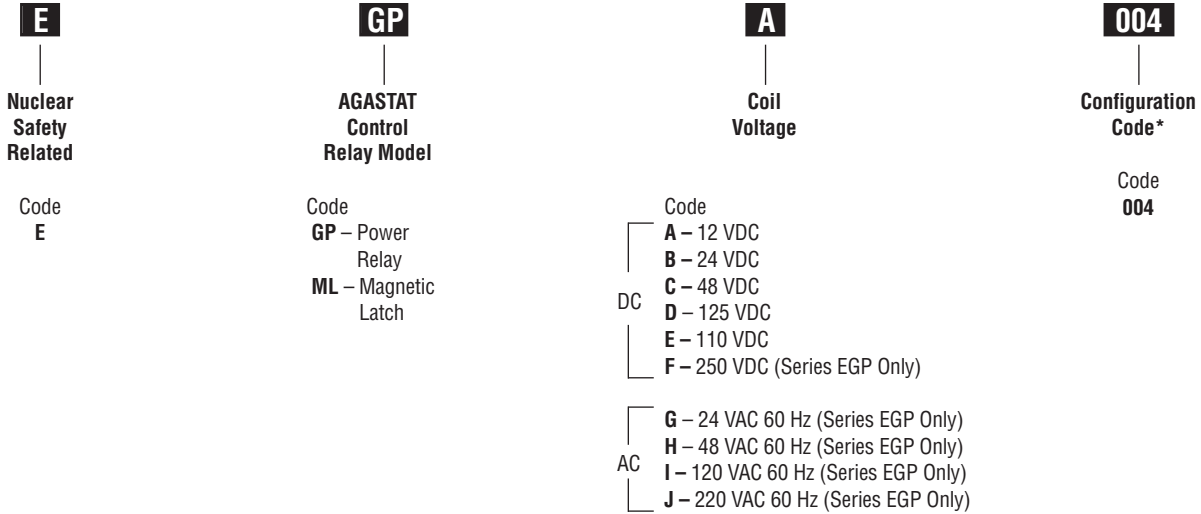

*** Configuration Code**

The Configuration Code is a suffix to the Model Number which provides a means of identification. When a significant product change is introduced, the Configuration code and specification sheets will be revised.

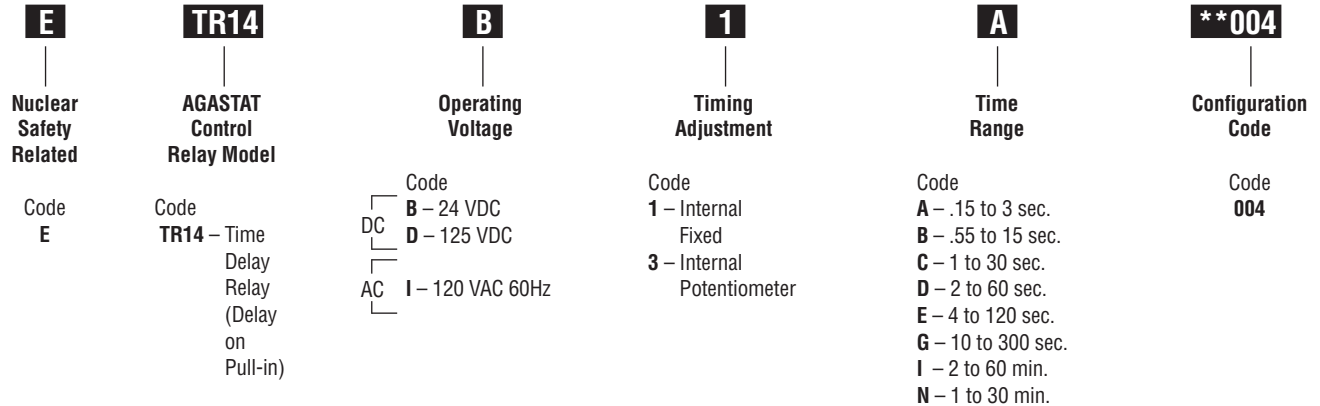

*** Configuration Code**

The Configuration Code is a suffix to the Model Number which provides a means of identification. When a significant product change is introduced, the Configuration code and specification sheets will be revised.

AGASTAT EGP/EML/ETR Series, Nuclear Qualified Control Relays (Continued)

Relay Classifications Control Code Summary

Configuration Control

Product	Code – 001	Code – 002	Code – 003	Code – 004
EGP	Contains all materials present in original qualification testing.	Nov. 1981 — Material change to coil wrapping tape and lead wire insulation to improve thermal life.	Dec. 1987 — Material change on leaf spring from nickel copper to beryllium copper.	Dec. 1995 — Material change on bobbin from Nylon ZYTEL 101 to RYNITE FR530. Material change on base from Melamine Phenolic to GRILON PMV-5HV0.
EML	Contains all materials present in original qualification testing.	Nov. 1981 — Material change to coil wrapping tape and lead wire insulation to improve thermal life.	Dec. 1987 — Material change on leaf spring from nickel copper to beryllium copper.	Dec. 1995 — Material change on bobbin from Nylon ZYTEL 101 to RYNITE FR530. Material change on base from Melamine Phenolic to GRILON PMV-5HV0.
ETR	Contains all materials present in original qualification testing.	Nov. 1981 — Material change to coil wrapping tape and lead wire insulation to improve thermal life.	Dec. 1987 — Material change on leaf spring from nickel copper to beryllium copper.	Dec. 1995 — Material change on bobbin from Nylon ZYTEL 101 to RYNITE FR530. Material change on base from Melamine Phenolic to GRILON PMV-5HV0.
ECR0001	Contains all materials present in original qualification testing.	June 1989 — Material change from NORYL N-225 std. black to NORYL SE-I-701AA black.		
ECR0002	Contains all materials present in original qualification testing.	June 1989 — Material change from NORYL N-225 std. black to NORYL SE-I-701AA black.		
ECR0095	Contains all materials present in original qualification testing.	June 1989 — Material change from NORYL N-225 std. black to NORYL SE-I-701AA black.		
ECR0133	Contains all materials present in original qualification testing.			
ECR0155	Contains all materials present in original qualification testing.			

Configuration Code: The Configuration code is a suffix to the Model Number which provides a means of identification. When a significant product change is introduced, the Configuration code and specification sheets will be revised. (001, 002, 003, 004, etc.)

GRILON is a trademark of EMS-Chemie AG.
 NORYL is a trademark of SABIC Innovative Plastics.
 RYNITE and ZYTEL are trademarks of E.I. du Pont de Nemours and Company.



Компания «ЭлектроПласт» предлагает заключение долгосрочных отношений при поставках импортных электронных компонентов на взаимовыгодных условиях!

Наши преимущества:

- Оперативные поставки широкого спектра электронных компонентов отечественного и импортного производства напрямую от производителей и с крупнейших мировых складов;
- Поставка более 17-ти миллионов наименований электронных компонентов;
- Поставка сложных, дефицитных, либо снятых с производства позиций;
- Оперативные сроки поставки под заказ (от 5 рабочих дней);
- Экспресс доставка в любую точку России;
- Техническая поддержка проекта, помощь в подборе аналогов, поставка прототипов;
- Система менеджмента качества сертифицирована по Международному стандарту ISO 9001;
- Лицензия ФСБ на осуществление работ с использованием сведений, составляющих государственную тайну;
- Поставка специализированных компонентов (Xilinx, Altera, Analog Devices, Intersil, Interpoint, Microsemi, Aeroflex, Peregrine, Syfer, Eurofarad, Texas Instrument, Miteq, Cobham, E2V, MA-COM, Hittite, Mini-Circuits, General Dynamics и др.);

Помимо этого, одним из направлений компании «ЭлектроПласт» является направление «Источники питания». Мы предлагаем Вам помощь Конструкторского отдела:

- Подбор оптимального решения, техническое обоснование при выборе компонента;
- Подбор аналогов;
- Консультации по применению компонента;
- Поставка образцов и прототипов;
- Техническая поддержка проекта;
- Защита от снятия компонента с производства.



Как с нами связаться

Телефон: 8 (812) 309 58 32 (многоканальный)

Факс: 8 (812) 320-02-42

Электронная почта: org@eplast1.ru

Адрес: 198099, г. Санкт-Петербург, ул. Калинина, дом 2, корпус 4, литера А.