

FAN54161

Battery Charging IC, 98% Efficient, Safe 6 A Direct with Regulation and Protection

The FAN54161UCX is a low loss direct charger which charges the battery safely at 6 A and provides active protection, regulation and monitoring features.

Integrated Protection and Regulation features control a pair of MOSFETs to ensure that the FAN54161UCX output voltage and current stay within a safe programmed operating range. Configurable hardware based safety features turn off the MOSFET in the event of a fault and notify the system.

An integrated 10-bit Analog-to-Digital Converter (ADC) provides real-time monitoring of input, output voltage, currents and temperature so that the system host or microcontroller can effectively use this information to optimize adapter and charger configuration.

Features

- Integrated Back-to-Back Common Source N-channel MOSFETs with Combined $R_{ON} = 11 \text{ m}\Omega$
- Maximum Input Voltage Tolerance of +22 V
- Reverse Input Voltage Tolerance of -2 V
- External N-channel MOSFET Drive Capability with Tolerance up to +32 V
- Regulation Modes
 - ◆ Charge Current
 - ◆ Input Current
 - ◆ Output Voltage
 - ◆ Battery Cell Voltage
- Hardware-based Safety Protections
 - ◆ Input Over-Voltage
 - ◆ Input Under-Voltage
 - ◆ Output Over-Voltage
 - ◆ Input Over-Current
 - ◆ Die Over-Temperature
 - ◆ Internal Switch Short
- 10-bit High-accuracy ADC

Typical Applications

- Mobile Devices
- Tablets



ON Semiconductor®

www.onsemi.com

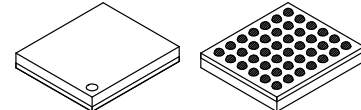

WLCSP42
CASE 567TY

MARKING DIAGRAM

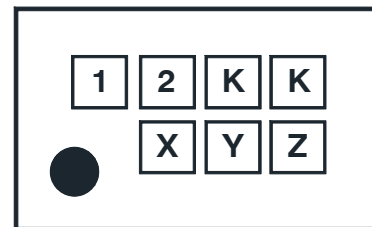

12 = Specific Device Code

KK = Lot Run Code

X = Year Code

Y = 2-Weeks Date Code

Z = Assembly Plant Code

ORDERING INFORMATION

See detailed ordering and shipping information on page 2 of this data sheet.

FAN54161

Block Diagram and Application Schematic

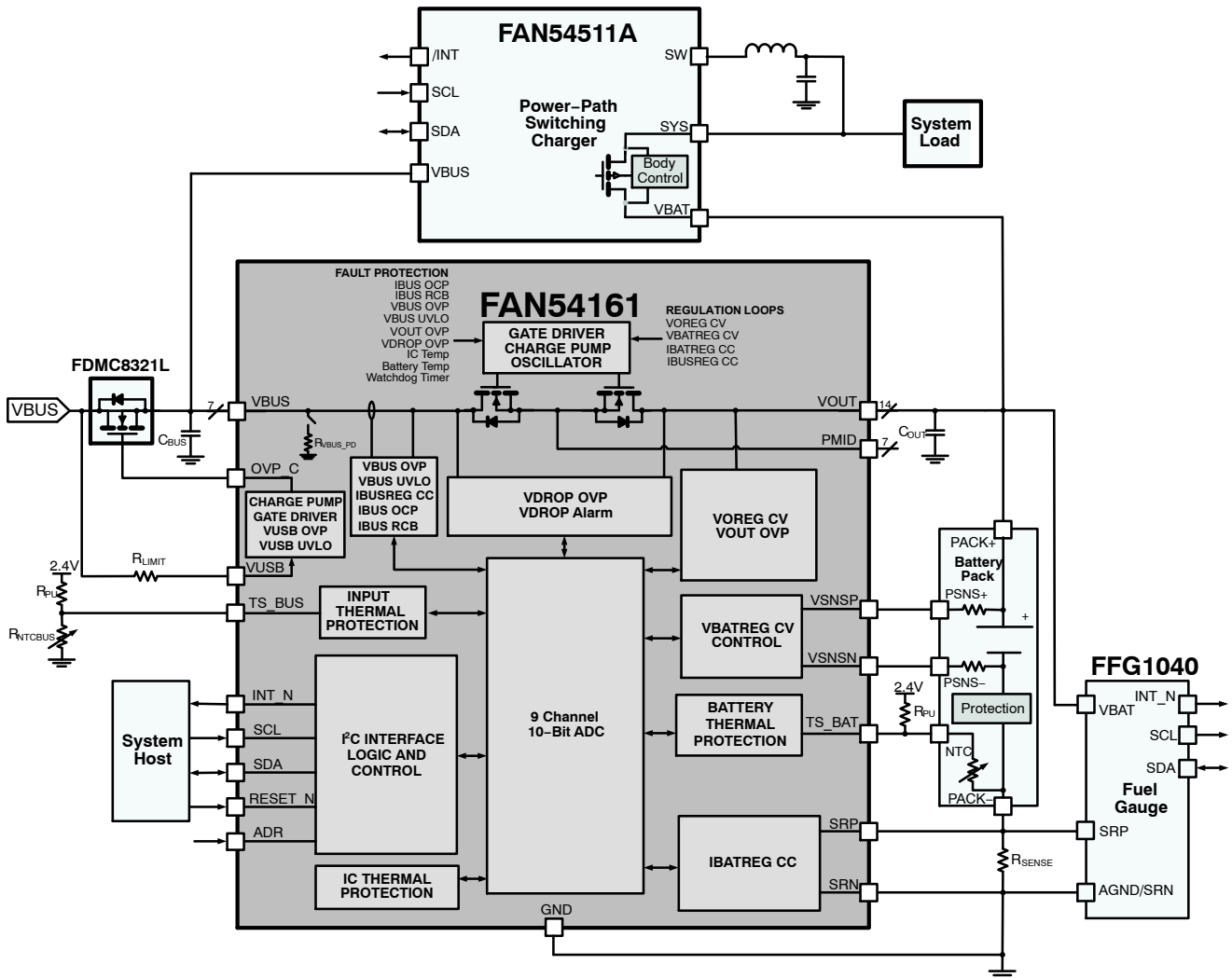

Figure 1. FAN54161, External FET, Switching Charger, Battery Pack with Exposed Cell, and External Fuel Gauge

RECOMMENDED COMPONENTS

Component	Manufacturer	Part Number	Value	Case Size	Rating
C _{BUS}	Murata	GRM188R61E105K	1.0 μ F	0603 (1608 metric)	25 V
C _{BUS} (alternative)	TDK	C1608X5R1E105K	1.0 μ F	0603 (1608 metric)	25 V
C _{OUT}	TDK	C1608X5R0J226M	22 μ F	0603 (1608 metric)	6.3 V
R _{SENSE}	Ohmite	MCS1632R010FER	0.01 (\pm 1%) Ohm	1206 (3216 metric)	1 W
R _{SENSE} (alternative)	Ohmite	MCS1632R005FER	0.005 (\pm 1%) Ohm	1206 (3216 metric)	1 W

ORDERING INFORMATION

Part Number	Temperature Range	Package	Packing Method
FAN54161UCX	-40°C to +85°C	2.78 x 3.06 mm, 42-Bump WLCSP	Tape and Reel

FAN54161

Pin Connections and Functional Description

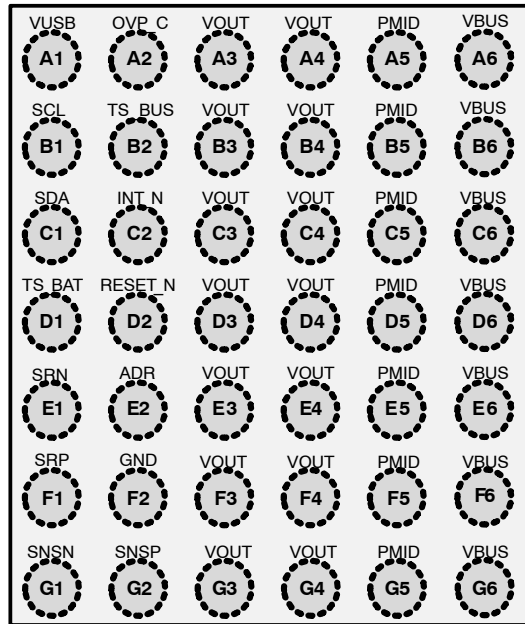

Figure 2. WLCSP-42 Pin Assignments

Table 1. PIN DESCRIPTIONS

Name	Position	Type	Description
ADR	E2	Digital Input	I²C Slave Device Address Selection Pin Refer to I ² C Interface section for details ADR logic level must be set before releasing RESET_N high. Recommend connecting this pin to the appropriate logic level before power is applied (VBUS or VOUT).
GND	F2	Ground	Device Ground Connect to the ground node in the PCB.
INT_N	C2	Open-Drain Digital Output	Interrupt Output (Active Low) Pull-up with 100 k Ω resistor to logic supply voltage. When an un-masked interrupt bit is set this pin will assert low. Connect to GND if not used.
RESET_N	D2	Digital Input	Reset Input (Active Low) 0 (Logic Low) – IC held in reset condition (lowest power state), switch is open, ADC is disabled, and I ² C communication is not available. 1 (Logic High) – IC logic allowed to operate, switch closed if SW_EN = 1; ADC enabled if ADC_EN = 1. If not used, it is recommended to pull-up to VOUT.
SCL	B1	Digital Input	I²C Serial Clock Input Pull-up with a resistor to logic supply voltage.
SDA	C1	Open-drain Digital I/O	I²C Serial Data Pull-up with a resistor to logic supply voltage.
VBUS	A6, B6, C6, D6, E6, F6, G6	Power Input	Switch Input, Device Supply and Input Voltage Sense Connect to the input power source of system. If an external N-channel MOSFET is used for protection, connect VBUS to the source of this MOSFET. VBUS has an internal 100 Ω pulldown resistor that is active when VBUSPD_EN = 1.
PMID	A5, B5, C5, D5, E5, F5, G5		Switch Common Source Point Leave floating. Connect to a floating copper plane to provide an additional thermal relief path to the PCB.

FAN54161

Table 1. PIN DESCRIPTIONS

Name	Position	Type	Description
VOUT	A3, A4, B3, B4, C3, C4, D3, D4, E3, E4, F3, F4, G3, G4	Power Output	Switch Output, Device Supply, and Output Voltage Sense Connect to the battery pack. VOUT will be regulated to a maximum level, relative to GND, as set by the VOREG(TH) register value.
SNSN	G1	Analog Input	Battery Cell Voltage Sense Negative Connect to the negative side of the cell inside the battery pack through a 1 k Ω resistor in series. If the battery pack does not provide access to the negative side of the cell, connect SNSN physically as close as possible to the negative terminal of the pack. If the voltage sensed across SNSP and SNSN tries to exceed the threshold $V_{BATREG(TH)}$, the voltage across SNSP and SNSN is regulated to the threshold.
SNSP	G2	Analog Input	Battery Cell Voltage Sense Positive Connect to the positive side of the cell inside the battery pack through a 1 k Ω resistor in series. If the voltage sensed across SNSP and SNSN tries to exceed the threshold $V_{BATREG(TH)}$, the voltage across SNSP and SNSN is regulated to the threshold. If the battery pack does not provide access to the positive side of the cell, connect SNSP to VOUT.
SRN	E1	Analog Input	Battery Current Sense Negative Connect to the negative side of the sense resistor in series with the cell. If the current through R_{SENSE} tries to exceed the threshold $I_{BATREG(TH)}$, the voltage across SRN and SRP is regulated to the threshold.
SRP	F1	Analog Input	Battery Current Sense Positive Connect to the positive side of the sense resistor in series with the cell. If the current through R_{SENSE} tries to exceed the threshold $I_{BATREG(TH)}$, the voltage across SRN and SRP is regulated to the threshold.
TS_BUS	B2	Analog Input	Thermistor Input for input connector temperature sense Connect an NTC thermistor from TS_BUS to GND. Connect a pull-up resistor from TS_BUS to an external 2.4 V supply. Connect to GND if not used.
TS_BAT	D1	Analog Input	Thermistor Input for battery temperature sense Connect an NTC thermistor from TS_BAT to GND. Connect a pull-up resistor from TS_BAT to an external 2.4 V supply. Connect to GND if not used.
VUSB	A1	Power Input	Input Voltage Sense for external VBUS over voltage protection control Connect this pin to the drain of external N-channel MOSFET (which is also the USB supply voltage) with a 500 Ω series resistor, R_{LIMIT} . The source of the external N-channel MOSFET must be connected to the VBUS pin. If an external MOSFET is not used, the VUSB pin must be left floating. Do not connect this pin to GND.
OVP_C	A2	Analog Output	Gate Control Output for external VBUS OVP blocking FET Connect to the gate of external N-channel MOSFET. If an external MOSFET is not used, the OVP_C pin should be tied to VBUS or float. Do not connect this pin to GND.

FAN54161

Table 2. ABSOLUTE MAXIMUM RATINGS (Notes 1, 2)

Symbol	Parameter	Min	Typ	Max	Units
V _{BUS}	Protected Input Supply Voltage, V _{BUS} to GND	-2.0		+22.0	V
V _{OUT}	Battery Voltage, V _{OUT} to GND	-0.3		+7.0	V
V _{USB}	Input connector sense pin, R _{LIMIT} = 500 Ω	-2.0		+32.0	V
V _{OVP_C}	OVP Gate Control Output, OVP_C = V _{BUS}	-2.0		+29.0	V
V _{SNSP} , V _{SRP} , V _{SRN}	Battery Positive Voltage and Current Sense, SNSP to GND, SRP to GND, SRN to GND	-0.3		+6.0	V
V _{SNSN}	Battery Negative Voltage Sense, SNSN to GND	-4.6		+6.0	V
V _{TS_BUS} , V _{TS_BAT}	Thermistor Voltage Sense Inputs, TS_BUS to GND, TS_BAT to GND	-0.3		+6.0	V
V _{IOD}	Digital Input and Open Drain Output Pins (SCL, SDA, ADR, RESET_N, INT_N)	-0.3		+6.0	V
I _{PASS}	Maximum Continuous Switch Current			7.50	A
T _A	Operating Free-air Temperature	-40		+85	°C
T _{J(MAX)}	Maximum Junction Temperature	-40		+150	°C
T _{STG}	Storage Temperature Range	-65		+150	°C
T _L	Lead Soldering Temperature, 10 secs			260	°C
ESD	Human-Body Model (HBM-JESD22-A114), V _{BUS} and V _{USB}	3000			V
	Human-Body Model (HBM-JESD22-A114), All Other Pins	2000			V
	Charged Device Model (CDM-JESD22-C101), All Pins	500			V

Stresses exceeding those listed in the Maximum Ratings table may damage the device. If any of these limits are exceeded, device functionality should not be assumed, damage may occur and reliability may be affected.

1. All voltages are referenced to ground, GND, unless otherwise noted.
2. Pins should be protected with external TVS devices when tested for IEC compliance.

Table 3. THERMAL CHARACTERISTICS

Symbol	Parameter	Conditions	Min	Typ	Max	Units
ThetaJA	Junction -to-Ambient Thermal Resistance	JEDEC, 2S2P, No Vias		50		°C/W

NOTES: Junction-to-ambient thermal resistance is a function of application and board layout. This data is measured with two-layer 2s2p boards in accordance to JEDEC standard JESD51. Special attention must be paid not to exceed junction temperature T_{J(max)} at a given ambient temperature T_A.

Table 4. RECOMMENDED OPERATING RANGES (Note 3)

The Recommended Operating Conditions table defines the conditions for actual device operation. Recommended operating conditions are specified to ensure optimal performance to the datasheet specifications. ON Semiconductor does not recommend exceeding them or designing to Absolute Maximum Ratings. The recommended operating conditions assume the following: V_{OUT} = 2.7 V to 4.5 V, V_{PU} = 1.8 V to 4.5 V, T_A = -40°C to 85°C, unless otherwise noted.

Symbol	Parameter	Min	Typ	Max	Units
V _{BUS}	Input Voltage	2.66		6.4	V
V _{USB}	Input Connector Voltage Sense	2.5		15	V
V _{OUT}	Battery Voltage	2.66		5.2	V
V _{SNSP}	Battery Positive Voltage Sense	2.66		5.2	V
V _{SNSN}	Battery Negative Voltage Sense	-0.2		+0.2	V
V _{SRP} , V _{SRN}	Battery Current Sense	-0.2		+0.2	V
V _{PU}	I ² C External Pull-up Supply Voltage	1.62		3.63	V
V _{TS_BUS} , V _{TS_BAT}	Thermistor Input Voltage Sense	0.1		2.3	V
T _A	Operating Free-air temperature	-40		+85	°C
T _J	Operating Junction Temperature	-30		+120	°C

Functional operation above the stresses listed in the Recommended Operating Ranges is not implied. Extended exposure to stresses beyond the Recommended Operating Ranges limits may affect device reliability.

3. All voltages are measured relative to GND.

FAN54161

Table 5. ELECTRICAL CHARACTERISTICS (Notes 4, 5, 6, 7) Unless otherwise specified: according to the circuit in Figure 1; recommended operating range for T_J and T_A ; The Recommended Operating Conditions for DC Electrical Characteristics assume $V_{OUT} = 2.7\text{ V}$ to 4.5 V and $T_A = -40^\circ\text{C}$ to 85°C , unless otherwise noted. Typical values are at $T_A = 25^\circ\text{C}$, $V_{OUT} = 3.8\text{ V}$, $V_{PU} = 1.8\text{ V}$.

Symbol	Parameter	Conditions	Min	Typ	Max	Units
SUPPLY CURRENT						
I_{ACTIVE}	Active Mode Current	Switch Closed, RESET_N=HIGH, $I_{PASS}=6\text{A}$, $V_{USB}=0\text{V}$, [ADC_EN]=0		5	9	mA
$I_{STANDBY_ADCOFF}$	VOUT Standby Mode Current	RESET_N=HIGH, [ADC_EN]=0, $V_{BUS}=\text{Open}$		5.5	10	μA
		RESET_N=HIGH, [ADC_EN]=0, $V_{BUS}=5\text{V}$		1.5	3.0	μA
$I_{SHUTDOWN}$	VOUT Shutdown Mode Current	RESET_N=LOW, $V_{BUS}=5\text{V}$		1.5	3.0	μA
		RESET_N=LOW, $V_{BUS}=\text{Open}$		1.5	3.0	μA
$I_{STANDBY_ADCOFF}$	VBUS Standby Mode Current	RESET_N=HIGH, [ADC_EN]=0, $V_{BUS}=5\text{V}$, $V_{OUT}=3.8\text{V}$		10	25	μA
		RESET_N=HIGH, [ADC_EN]=0, $V_{BUS}=5\text{V}$, $V_{OUT}=\text{Open}$		10	25	μA
$I_{SHUTDOWN}$	VBUS Shutdown Mode Current	RESET_N=LOW, $V_{BUS}=5\text{V}$, $V_{OUT}=3.8\text{V}$		3	18	μA
		RESET_N=LOW, $V_{BUS}=5\text{V}$, $V_{OUT}=\text{Open}$		3	18	μA
I_{VUSB}	VUSB Quiescent Current	$V_{USB}=5\text{V}$		63	100	μA
SWITCH CHARACTERISTICS						
R_{ON}	On-Resistance from VBUS to VOUT	$3.0 < V_{OUT} < 4.5\text{V}$, $I_{PASS}=1\text{A}$, $T_A = 25^\circ\text{C}$		11		$\text{m}\Omega$
R_{VBUS_PD}	VBUS Pulldown Resistance	[VBUSPD_EN] = 1	80	100	120	Ω
SWITCH DYNAMIC CHARACTERISTICS						
t_{ENABLE}	Switch Turn_On Time	$V_{BUS}=5\text{V}$, $V_{OUT}=3.8\text{V}$, [SW_EN]=0 to 1, [ADC_EN]=0, RESET_N=HIGH, [IBUS-REG]=3.5A		1.7		ms
		$V_{BUS}=5\text{V}$, $V_{OUT}=3.8\text{V}$, [SW_EN]=0 to 1, [ADC_EN]=1, RESET_N=HIGH, [IBUS-REG]=3.5A		1.6		ms
$t_{DISABLE}$	Switch Turn_Off Time	[SW_EN] = 1 to 0		0.4		ms
t_{OFF_BUSOVP}	Time to Isolate VBUS from VOUT for VBUS OVP	V_{BUS} Overdrive = 100 mV above $V_{BUSOVP}(\text{th})$		5.7		μs
$t_{OFF_BUSUVLO}$	Time to Isolate VBUS from VOUT for VBUS UVLO	V_{BUS} Underdrive = 100 mV below $V_{BUSUVLO}(\text{th})$		5.7		μs
$t_{OFF_VDROPOVP}$	Time to Isolate VBUS from VOUT for VDROPOVP	$(V_{BUS}-V_{OUT})$ Overdrive = 10 mV above $VDROPOVP(\text{TH})$		5.7		μs
$t_{OFF_IBUSOCP}$	Time to Isolate VBUS from VOUT for IBUS Over Current Fault	I_{PASS} Overdrive = 200 mA above $I_{BUSOCP}(\text{TH})$, no Regulation Mode control (Note 9)		425		μs
t_{OFF_TSHDN}	Time to Isolate VBUS from VOUT for Die Over Temperature Fault	$T_J > T_{SDN}(\text{TH})$		1.2		ms
t_{OFF_RCB}	Time to Isolate VBUS from VOUT for Reverse Current Fault	$(V_{OUT} - V_{BUS})$ Overdrive = 10 mV above $VRCB(\text{TH})$		10		μs
t_{WL_RESET}	RESET_N Input Pulse Width Low		1200			μs

4. $V_{IH(\text{max})} = V_{PU} + 0.5\text{ V}$ or V_{BAT} whichever is lower

5. It is assumed that the SCL and SDA pins are open drain with external pull-ups resistors tied to an external supply V_{PU} .

6. V_{IH} and V_{IL} have been chosen to be fully compliant to I²C specification at $V_{PU} = 1.8\text{ V} \pm 10\%$. At $2.25\text{ V} \leq V_{PU} \leq 3.63\text{ V}$ the $V_{IL(\text{max})}$ provides > 200 mV on noise margin to the required $V_{OL(\text{max})}$ of the transmitter.

7. I²C standard specifies $V_{OL(\text{max})}$ for $V_{PU} \leq 2.0\text{ V}$ to be $0.2 \times V_{PU}$.

8. Guaranteed by design. Not tested in production.

9. Regulation Mode control will reduce $t_{OFF_IBUSOCP}$.

FAN54161

Table 5. ELECTRICAL CHARACTERISTICS (Notes 4, 5, 6, 7) Unless otherwise specified: according to the circuit in Figure 1; recommended operating range for T_J and T_A ; The Recommended Operating Conditions for DC Electrical Characteristics assume $V_{OUT} = 2.7\text{ V}$ to 4.5 V and $T_A = -40^\circ\text{C}$ to 85°C , unless otherwise noted. Typical values are at $T_A = 25^\circ\text{C}$, $V_{OUT} = 3.8\text{ V}$, $V_{PU} = 1.8\text{ V}$.

Symbol	Parameter	Conditions	Min	Typ	Max	Units
--------	-----------	------------	-----	-----	-----	-------

SWITCH DYNAMIC CHARACTERISTICS

$t_{RL_RESETI2C}$	RESET_N Release to I ² C Delay Time	Duration required between rising edge of RESET_N and first I2C START (Note 8)	120			μs
--------------------	--	---	-----	--	--	---------------

HARDWARE PROTECTION (Bypass Switch)

$V_{BUSOVP(TH)}$	VBUS OVP Threshold Range		4.2		6.5	V
	VBUS OVP Threshold Stepsize			25		mV
	VBUS OVP Threshold Accuracy	$[VBUSOVP_TH] = 6.5\text{ V}$	6.4	6.5	6.6	V
$t_{BUSOVPGLTCH}$	VBUS OVP Deglitch Time	$[OVP_DLY]=0$		4		μs
		$[OVP_DLY]=1$		20		μs
$V_{BUSUVLO(TH)}$	VBUS UVLO Threshold	$V_{BUS} > V_{BUSUVLO(TH)}$ allows the switch to close	2.84	2.9	2.96	V
$V_{BUSUVLO(HYS)}$	VBUS UVLO Hysteresis	Falling		300		mV
$t_{BUSUVLOGLTCH}$	VBUS UVLO Deglitch Time			4		μs
$V_{DROPOVP(TH)}$	VDROP OVP Threshold Range	$V_{BUS} - V_{OUT}$	0		1000	mV
	VDROP OVP Threshold Stepsize	$V_{BUS} - V_{OUT}$		5		mV
	VDROP OVP Threshold Accuracy	$V_{BUS} - V_{OUT}$, $2.66\text{ V} < V_{OUT} < 4.5\text{ V}$, $[VDROPOVP_TH]=300\text{mV}$	295	300	305	mV
$t_{VDROPGLTCH}$	VDROP OVP Deglitch Time	$[OVP_DLY]=0$		4		μs
		$[OVP_DLY]=1$		20		μs
$V_{DROPALM(TH)}$	VDROP Alarm Threshold Range	$V_{BUS} - V_{OUT}$	0		1000	mV
	VDROP Alarm Threshold Stepsize	$V_{BUS} - V_{OUT}$		5		mV
	VDROP Alarm Threshold Accuracy	$V_{BUS} - V_{OUT}$, $2.66\text{ V} < V_{OUT} < 4.5\text{ V}$, $[VDROPOVP_TH]=100\text{mV}$	80	100	115	mV
$t_{VDROPALMGLTCH}$	VDROP Alarm Deglitch Time	$[OVP_DLY]=0$		4		μs
		$[OVP_DLY]=1$		20		μs
$I_{BUSOCP(TH)}$	IBUS OCP Threshold Range		0.5		7.5	A
	IBUS OCP Threshold Stepsize			500		mA
	IBUS OCP Threshold Accuracy	$2.66\text{ V} < V_{OUT} < 4.5\text{ V}$, $[IBUSOCP_TH]=5\text{A}$	4.75	5.00	5.25	A
$t_{IBUSOCPGLTCH}$	IBUS OCP Deglitch Time	$[IBUSOCP_MODE]=0$		50		μs
		$[IBUSOCP_MODE]=1$; Deglitch time before entering Hiccup Mode		8		μs
t_{HICCUP}	IBUS OCP Hiccup Mode Retry Time	$[IBUSOCP_MODE]=1$	80	100	125	ms
$I_{RCB(TH)}$	RCB Threshold	$[IRCB]=0$, Current from V_{OUT} to V_{BUS} , $V_{BUS} \geq 3\text{ V}$	-100	100	+300	mA
		$[IRCB]=1$, Current from V_{OUT} to V_{BUS} , $V_{BUS} \geq 3\text{ V}$	2.6	3	3.3	A
$t_{RCBGLTCH}$	RCB Deglitch Time			8		μs

4. $V_{IH(max)} = V_{PU} + 0.5\text{ V}$ or V_{BAT} whichever is lower

5. It is assumed that the SCL and SDA pins are open drain with external pull-ups resistors tied to an external supply V_{PU} .

6. V_{IH} and V_{IL} have been chosen to be fully compliant to I²C specification at $V_{PU} = 1.8\text{ V} \pm 10\%$. At $2.25\text{ V} \leq V_{PU} \leq 3.63\text{ V}$ the $V_{IL(max)}$ provides $> 200\text{ mV}$ on noise margin to the required $V_{OL(max)}$ of the transmitter.

7. I²C standard specifies $V_{OL(max)}$ for $V_{PU} \leq 2.0\text{ V}$ to be $0.2 \times V_{PU}$.

8. Guaranteed by design. Not tested in production.

9. Regulation Mode control will reduce $t_{OFF_IBUSOCP}$.

FAN54161

Table 5. ELECTRICAL CHARACTERISTICS (Notes 4, 5, 6, 7) Unless otherwise specified: according to the circuit in Figure 1; recommended operating range for T_J and T_A ; The Recommended Operating Conditions for DC Electrical Characteristics assume $V_{OUT} = 2.7\text{ V}$ to 4.5 V and $T_A = -40^\circ\text{C}$ to 85°C , unless otherwise noted. Typical values are at $T_A = 25^\circ\text{C}$, $V_{OUT} = 3.8\text{ V}$, $V_{PU} = 1.8\text{ V}$.

Symbol	Parameter	Conditions	Min	Typ	Max	Units
HARDWARE PROTECTION (Bypass Switch)						
$T_{SDN(TH)}$	Thermal Shutdown Threshold Range		115		145	$^\circ\text{C}$
	Thermal Shutdown Threshold Step Size			10		$^\circ\text{C}$
	Thermal Shutdown Threshold	$3.0\text{V} < V_{BUS} < 5.9\text{V}$, $[T_{JSHDN}] = 125^\circ\text{C}$		125		$^\circ\text{C}$
$t_{SDGLTCH}$	Thermal Shutdown Deglitch Time			800		μs
V_{FAIL}	VFAIL Short Detect Threshold	Active only when $SW_EN=0$, $ADC_EN=1$	1.9	2	2.2	V
R_{VFAIL}	VFAIL Pulldown Resistor (PMID to GND)	Active only when $SW_EN=0$		23		$\text{k}\Omega$
t_{VFAIL_GLTCH}	VFAIL Deglitch Time			4		μs
$V_{BATINSERT(TH)}$	VBAT Insert Voltage	$V_{BUS} > V_{BUSUVLO(TH)}$; V_{SNSP} rising above $V_{BATINSERT(TH)}$ indicates a connected battery.	1.9	2.0	2.2	V
$V_{BATINSERT(HYS)}$	VBAT Insert Hysteresis	Falling		100		mV
$V_{OUTOVP(TH)}$	VOUT OVP Threshold Range		4.5		5.3	V
	VOUT OVP Threshold	$[V_{OUTOVP_TH}] = 4.7\text{V}$	4.55	4.7	4.85	
$V_{OUTOVP(HYS)}$	VOUT OVP Hysteresis	Falling		100		mV
$t_{VOUTOVPGLTCH}$	VOUT OVP Deglitch Time	$[V_{OUTOVP_DLY}] = 0$		4		μs
		$[V_{OUTOVP_DLY}] = 1$		20		μs

VOUT VOLTAGE REGULATION

$V_{OREG(TH)}$	VOREG Regulation Threshold Range		4.2		5	V
	VOREG Regulation Threshold Step Size			10		mV
	VOREG Regulation Threshold Accuracy	$[V_{OREG}] = 4.4\text{V}$, $T_J = 25^\circ\text{C}$	-10		+10	mV

VBAT VOLTAGE REGULATION

$V_{BATREG(TH)}$	VBATREG Regulation Threshold Range	$V_{SNSP} - V_{SNSN}$	4.2		5	V
	VBATREG Regulation Threshold Step Size	$V_{SNSP} - V_{SNSN}$		10		mV
	VBATREG Regulation Threshold Accuracy	$[V_{BATREG}] = 4.3\text{V}$, $T_J = 25^\circ\text{C}$	-10		+10	mV

- $V_{IH(max)} = V_{PU} + 0.5\text{ V}$ or V_{BAT} whichever is lower
- It is assumed that the SCL and SDA pins are open drain with external pull-ups resistors tied to an external supply V_{PU} .
- V_{IH} and V_{IL} have been chosen to be fully compliant to I²C specification at $V_{PU} = 1.8\text{ V} \pm 10\%$. At $2.25\text{ V} \leq V_{PU} \leq 3.63\text{ V}$ the $V_{IL(max)}$ provides $> 200\text{ mV}$ on noise margin to the required $V_{OL(max)}$ of the transmitter.
- I²C standard specifies $V_{OL(max)}$ for $V_{PU} \leq 2.0\text{ V}$ to be $0.2 \times V_{PU}$.
- Guaranteed by design. Not tested in production.
- Regulation Mode control will reduce $t_{OFF_IBUSOCP}$.

FAN54161

Table 5. ELECTRICAL CHARACTERISTICS (Notes 4, 5, 6, 7) Unless otherwise specified: according to the circuit in Figure 1; recommended operating range for T_J and T_A ; The Recommended Operating Conditions for DC Electrical Characteristics assume $V_{OUT} = 2.7\text{ V}$ to 4.5 V and $T_A = -40^\circ\text{C}$ to 85°C , unless otherwise noted. Typical values are at $T_A = 25^\circ\text{C}$, $V_{OUT} = 3.8\text{ V}$, $V_{PU} = 1.8\text{ V}$.

Symbol	Parameter	Conditions	Min	Typ	Max	Units
--------	-----------	------------	-----	-----	-----	-------

IBAT CURRENT REGULATION

$I_{BATREG(TH)}$	IBATREG Regulation Threshold Range	$V_{SRP} - V_{SRN}$ sensed across R_{SENSE} .	0.1		6.35	A
	IBATREG Regulation Threshold Stepsize			50		mA
	IBATREG Regulation Threshold Accuracy	$2.5\text{ V} < V_{OUT} < 4.5\text{ V}$, $R_{SENSE}=10\text{ m}\Omega$, $[IBATREG]=2\text{ A}$	-5		+5	%
		$2.5\text{ V} < V_{OUT} < 4.5\text{ V}$, $R_{SENSE}=5\text{ m}\Omega$, $[IBATREG]=4\text{ A}$	-5		+5	%

IBUS CURRENT REGULATION

$I_{BUSREG(TH)}$	IBUSREG Regulation Threshold Range		0.1		6.5	A
	IBUSREG Regulation Threshold Stepsize			50		mA
	IBUSREG Regulation Threshold Accuracy	$2.66 < V_{OUT} < 4.5$; $[IBUSREG] = 3.5\text{ A}$	-5		+5	%

BATTERY CELL VOLTAGE SENSE INPUTS (VSNSP, VSNSN)

I_{SNSP}	SNSP Input Current	$2.66\text{ V} < V_{SNSP} < 4.5\text{ V}$			5	μA
I_{SNSN}	SNSN Input Current	$0.0\text{ V} < V_{SNSN} < 0.2\text{ V}$			1	μA

LOGIC LEVELS (SCL, SDA, ADR, INT_N, RESET_N)

V_{IH}	Input High Voltage Level		1.05			V
V_{IL}	Input Low Voltage Level				0.4	V
V_{OL}	Output Low Voltage, INT_N, SDA	$I_{OL} = 3\text{ mA}$			0.4	V
I_{IN}	Input current each I/O pin	$V_{PIN} = 0\text{ V}$ or 5 V	-10		+10	μA

BATTERY CURRENT SENSE INPUTS (VSRP, VSRN)

I_{SRP}	V_{SRP} Input Current	$0 < V_{SRP} < 0.2$			1	μA
I_{SRN}	V_{SRN} Input Current	$-0.2 < V_{SRN} < 0$	-1			μA

WATCH DOG TIMER

t_{WDT}	Watchdog Timer Range		0.5		2	s
	Watchdog Timer Accuracy	All [WDT] Settings	-10		+10	%

ANALOG TO DIGITAL CONVERTER

RES	Resolution	(Note 8)	10			Bits
INL	Integral Non-Linearity			± 1		LSB
DNL	Differential Non-Linearity			± 1		LSB
OE	Offset Error			± 1		LSB
GE	Gain Error (Full Scale Error)			± 1		LSB
f_{CONV}	Conversion Clock		2.7	3.0	3.3	MHz

4. $V_{IH(max)} = V_{PU} + 0.5\text{ V}$ or V_{BAT} whichever is lower

5. It is assumed that the SCL and SDA pins are open drain with external pull-ups resistors tied to an external supply V_{PU} .

6. V_{IH} and V_{IL} have been chosen to be fully compliant to I²C specification at $V_{PU} = 1.8\text{ V} \pm 10\%$. At $2.25\text{ V} \leq V_{PU} \leq 3.63\text{ V}$ the $V_{IL(max)}$ provides $> 200\text{ mV}$ on noise margin to the required $V_{OL(max)}$ of the transmitter.

7. I²C standard specifies $V_{OL(max)}$ for $V_{PU} \leq 2.0\text{ V}$ to be $0.2 \times V_{PU}$.

8. Guaranteed by design. Not tested in production.

9. Regulation Mode control will reduce $t_{OFF_IBUSOCP}$.

FAN54161

Table 5. ELECTRICAL CHARACTERISTICS (Notes 4, 5, 6, 7) Unless otherwise specified: according to the circuit in Figure 1; recommended operating range for T_J and T_A ; The Recommended Operating Conditions for DC Electrical Characteristics assume $V_{OUT} = 2.7\text{ V}$ to 4.5 V and $T_A = -40^\circ\text{C}$ to 85°C , unless otherwise noted. Typical values are at $T_A = 25^\circ\text{C}$, $V_{OUT} = 3.8\text{ V}$, $V_{PU} = 1.8\text{ V}$.

Symbol	Parameter	Conditions	Min	Typ	Max	Units
ANALOG TO DIGITAL CONVERTER						
t_{THR_ONE}	Throughput time (Single-shot conversion)	No Averaging, 1 channel, One-shot conversion (ADC_RATE = 0, ADC_EN written from 0 to 1)		47		μs
		8-sample Averaging (AVG_EN=1, SAMPLES=0), 1 channel, One-shot conversion (ADC_RATE = 0, ADC_EN written from 0 to 1)		84		μs
		16-sample Averaging (AVG_EN=1, SAMPLES=1), 1 channel, One-shot conversion (ADC_RATE = 0, ADC_EN written from 0 to 1)		127		μs
		16-sample Averaging (AVG_EN=1, SAMPLES=1), 9 channels, One-shot conversion (ADC_RATE = 0, ADC_EN written from 0 to 1)		1031		μs
t_{THR_CONT}	Throughput time (Continuous Conversion)	No Averaging, 1 channel, Continuous conversion (ADC_RATE = 1, ADC_EN=1)		33		μs
		8-sample Averaging (AVG_EN=1, SAMPLES=0), 1 channel, Continuous conversion (ADC_RATE = 1, ADC_EN=1)		70		μs
		16-sample Averaging (AVG_EN=1, SAMPLES=1), 1 channel, Continuous conversion (ADC_RATE = 1, ADC_EN=1)		113		μs
		16-sample Averaging (AVG_EN=1, SAMPLES=1), 9 channels, Continuous conversion (ADC_RATE = 1, ADC_EN=1)		1018		μs
GAIN _{IBAT}	Battery Current ADC Gain Range	RSENSE = 0		40		V/V
		RSENSE = 1		20		V/V
V _{BUS} _{ADC}	V _{BUS} Channel Full Scale Range	Signal sensed at V _{BUS} pin, 7.3 mV per LSB	0		6.1	V
V _{BAT} _{ADC}	V _{BAT} Channel Full Scale Range	Signal sensed across and SNSP and SNSN pins, 5.3 mV per LSB	2.5		5.0	V
V _{OUT} _{ADC}	V _{OUT} Channel Full Scale Range	Signal sensed at V _{OUT} , 5.3 mV per LSB	0		5.0	V
V _{DROP} _{ADC}	V _{DROP} Channel Full Scale Range	Signal sensed between V _{BUS} and V _{OUT} pins, 2.9 mV per LSB	0		1.0	V
I _{BUS} _{ADC}	I _{BUS} Channel Full Scale Range	Signal sensed across internal switch, 14.6 mA per LSB	0		7.0	A
I _{BAT} _{ADC}	I _{BAT} Channel Full Scale Range	Signal sensed across SRP and SRN pins, 14.6 mA per LSB	-7.0		+7.0	A
T _{BUS} _{BAT} _{ADC}	T _{BUS} and T _{BAT} Channel Full Scale Range	Signal sensed at TS _{BUS} and TS _{BAT} pins, 2.9 mV per LSB respectively	0		2.4	V
$t_{TBUS_TBAT_GLTCH}$	T _{BUS} and T _{BAT} Temperature Fault Deglitch Time	Deglitch time to open switch when V _{TBUS} falls below TBUS_TH or V _{TBAT} falls below TBAT_TH	0.9	1	1.1	s
TDIE _{ADC}	TDIE Channel Full Scale Range	Signal sensed by internal temperature sensor, 1°C per LSB	25		150	°C

4. $V_{IH(max)} = V_{PU} + 0.5\text{ V}$ or V_{BAT} whichever is lower

5. It is assumed that the SCL and SDA pins are open drain with external pull-ups resistors tied to an external supply V_{PU} .

6. V_{IH} and V_{IL} have been chosen to be fully compliant to I²C specification at $V_{PU} = 1.8\text{ V} \pm 10\%$. At $2.25\text{ V} \leq V_{PU} \leq 3.63\text{ V}$ the $V_{IL(max)}$ provides > 200 mV on noise margin to the required $V_{OL(max)}$ of the transmitter.

7. I²C standard specifies $V_{OL(max)}$ for $V_{PU} \leq 2.0\text{ V}$ to be $0.2 \times V_{PU}$.

8. Guaranteed by design. Not tested in production.

9. Regulation Mode control will reduce $t_{OFF_IBUSOCP}$.

FAN54161

Table 5. ELECTRICAL CHARACTERISTICS (Notes 4, 5, 6, 7) Unless otherwise specified: according to the circuit in Figure 1; recommended operating range for T_J and T_A ; The Recommended Operating Conditions for DC Electrical Characteristics assume $V_{OUT} = 2.7\text{ V}$ to 4.5 V and $T_A = -40^\circ\text{C}$ to 85°C , unless otherwise noted. Typical values are at $T_A = 25^\circ\text{C}$, $V_{OUT} = 3.8\text{ V}$, $V_{PU} = 1.8\text{ V}$.

Symbol	Parameter	Conditions	Min	Typ	Max	Units
OVP_C CONTROL (External OVP FET Control)						
$V_{USBOVP(TH)}$	VUSB OVP Threshold	$V_{USB} > V_{USBOVP(TH)}$ drives OVP_C low	15	16.5	18	V
$V_{USBOVP(HYS)}$	VUSB OVP Hysteresis	V_{USB} Falling		1		V
$V_{USBVLO(TH)}$	VUSB UVLO Threshold	$V_{USBOVP(TH)} > V_{USB} > V_{USBVLO(TH)}$ will drive OVP_C high	2.5	2.6	2.7	V
$V_{USBVLO(HYS)}$	VUSB UVLO Hysteresis	Falling, $V_{USB} < V_{USBVLO(TH)} - V_{USBVLO(HYS)}$ will drive OVP_C low		200		mV
OVP_C(HI)	OVP_C Gate Drive Voltage	$V_{USBVLO(TH)} < V_{USB} < V_{USBOVP(TH)}$; measured from OVP_C to VBUS	4.5	4.8	5.1	V
t_{OFF_USBOVP}	OVP_C Gate Turn-Off Time	Gate Capacitance = 5.2nF; 2V/ μ s V_{USB} ramp rate; Time from V_{USB} rising above $V_{USBOVP(TH)}$ to external FET open (where VBUS stops increasing); V_{USB} comparator delay included; FDMC8321L N-Channel FET		0.7		μ s

I²C TIMING SPECIFICATIONS

f_{SCL}	SCL Clock Frequency	Standard Mode			100	kHz
		Fast Mode			400	kHz
		Fast Mode Plus			1000	kHz
t_{BUF}	Bus-Free Time Between STOP and START Conditions	Standard Mode		4.7		μ s
		Fast Mode		1.3		μ s
		Fast Mode Plus		0.5		μ s
$t_{HD;STA}$	START or Repeated START Hold Time	Standard Mode		4		μ s
		Fast Mode		600		ns
		Fast Mode Plus		260		ns
t_{LOW}	SCL LOW Period	Standard Mode		4.7		μ s
		Fast Mode		1.3		μ s
		Fast Mode Plus		0.5		μ s
t_{HIGH}	SCL HIGH Period	Standard Mode		4		μ s
		Fast Mode		600		ns
		Fast Mode-Plus		260		ns
$t_{SU;STA}$	Repeated START Setup Time	Standard Mode		4.7		μ s
		Fast Mode		600		ns
		Fast Mode-Plus		260		ns
$t_{SU;DAT}$	Data Setup Time	Standard Mode		250		ns
		Fast Mode		100		ns
		Fast Mode Plus		50		ns

4. $V_{IH(max)} = V_{PU} + 0.5\text{ V}$ or V_{BAT} whichever is lower

5. It is assumed that the SCL and SDA pins are open drain with external pull-ups resistors tied to an external supply V_{PU} .

6. V_{IH} and V_{IL} have been chosen to be fully compliant to I²C specification at $V_{PU} = 1.8\text{ V} \pm 10\%$. At $2.25\text{ V} \leq V_{PU} \leq 3.63\text{ V}$ the $V_{IL(max)}$ provides > 200 mV on noise margin to the required $V_{OL(max)}$ of the transmitter.

7. I²C standard specifies $V_{OL(max)}$ for $V_{PU} \leq 2.0\text{ V}$ to be $0.2 \times V_{PU}$.

8. Guaranteed by design. Not tested in production.

9. Regulation Mode control will reduce $t_{OFF_IBUSOCP}$

FAN54161

Table 5. ELECTRICAL CHARACTERISTICS (Notes 4, 5, 6, 7) Unless otherwise specified: according to the circuit in Figure 1; recommended operating range for T_J and T_A ; The Recommended Operating Conditions for DC Electrical Characteristics assume $V_{OUT} = 2.7\text{ V}$ to 4.5 V and $T_A = -40^\circ\text{C}$ to 85°C , unless otherwise noted. Typical values are at $T_A = 25^\circ\text{C}$, $V_{OUT} = 3.8\text{ V}$, $V_{PU} = 1.8\text{ V}$.

Symbol	Parameter	Conditions	Min	Typ	Max	Units
I²C TIMING SPECIFICATIONS						
$t_{HD;DAT}$	Data Hold Time	Standard Mode	0		3.45	μs
		Fast Mode	0		900	ns
		Fast Mode Plus	0		450	ns
t_{RCL}	SCL Rise Time	Standard Mode	$20 + 0.1C_b$		1000	ns
		Fast Mode	$20 + 0.1C_b$		300	ns
		Fast Mode Plus	$20 + 0.1C_b$		120	ns
t_{RDA}	SDA Rise Time	Standard Mode	$20 + 0.1C_b$		1000	ns
		Fast Mode	$20 + 0.1C_b$		300	ns
		Fast Mode Plus	$20 + 0.1C_b$		120	ns
t_{FDA}	SDA Fall Time	Standard Mode	$20 + 0.1C_b$		300	ns
		Fast Mode	$20 + 0.1C_b$		300	ns
		Fast Mode Plus	$20 + 0.1C_b$		120	ns
$t_{SU;STO}$	Stop Condition Setup Time	Standard Mode		4		μs
		Fast Mode		600		ns
		Fast Mode Plus		120		ns
C_b	Capacitive Load for SDA and SCL				400	pF
t_{SP}	Pulse width of spikes which must be suppressed by input filter	SCL, SDA only	0		50	ns

4. $V_{IH(max)} = V_{PU} + 0.5\text{ V}$ or V_{BAT} whichever is lower
5. It is assumed that the SCL and SDA pins are open drain with external pull-ups resistors tied to an external supply V_{PU} .
6. V_{IH} and V_{IL} have been chosen to be fully compliant to I²C specification at $V_{PU} = 1.8\text{ V} \pm 10\%$. At $2.25\text{ V} \leq V_{PU} \leq 3.63\text{ V}$ the $V_{IL(max)}$ provides $> 200\text{ mV}$ on noise margin to the required $V_{OL(max)}$ of the transmitter.
7. I²C standard specifies $V_{OL(max)}$ for $V_{PU} \leq 2.0\text{ V}$ to be $0.2 \times V_{PU}$.
8. Guaranteed by design. Not tested in production.
9. Regulation Mode control will reduce $t_{OFF_IBUSOCP}$.

Product parametric performance is indicated in the Electrical Characteristics for the listed test conditions, unless otherwise noted. Product performance may not be indicated by the Electrical Characteristics if operated under different conditions.

Typical Characteristics

Unless otherwise specified: Default register settings, $T_A = 25^\circ\text{C}$, $V_{OUT} = 3.8\text{ V}$, $V_{PU} = 1.8\text{ V}$.

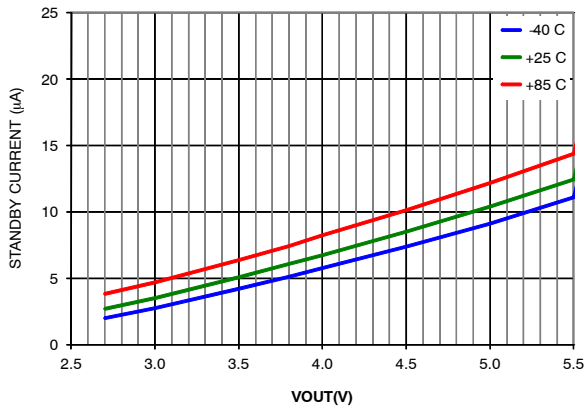

Figure 3. VOUT Standby Current, VBUS=Open, [ADC_EN]=0, RESET_N=HIGH

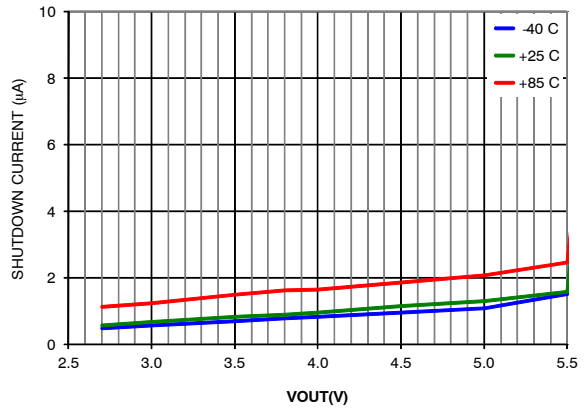

Figure 4. VOUT Shutdown Current, VBUS=Open, RESET_N=LOW

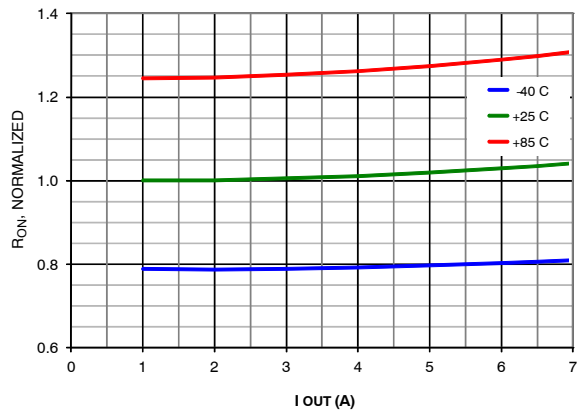

Figure 5. On Resistance from VBUS to VOUT, Normalized to 1.0 A/25°C

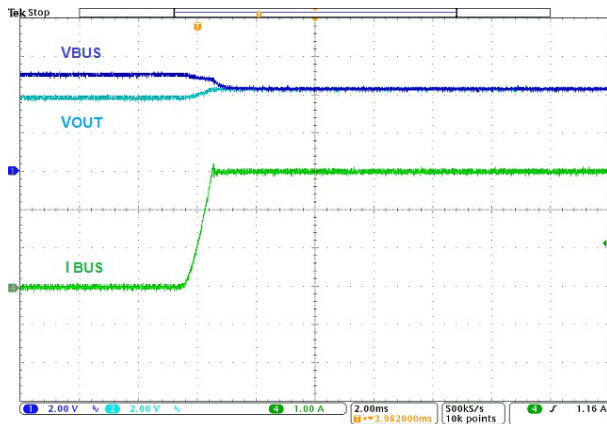

Figure 6. Switch Closing, [SW_EN]=0 to 1, TA Configured for 5 V/3 A

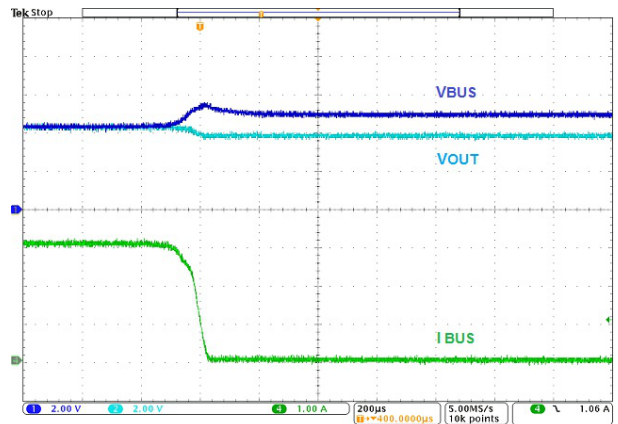

Figure 7. Switch Opening, [SW_EN]=1 to 0, TA Configured for 5 V/3 A

Typical Characteristics

Unless otherwise specified: Default register settings, $T_A = 25^\circ\text{C}$, $V_{OUT} = 3.8\text{ V}$, $V_{PU} = 1.8\text{ V}$.

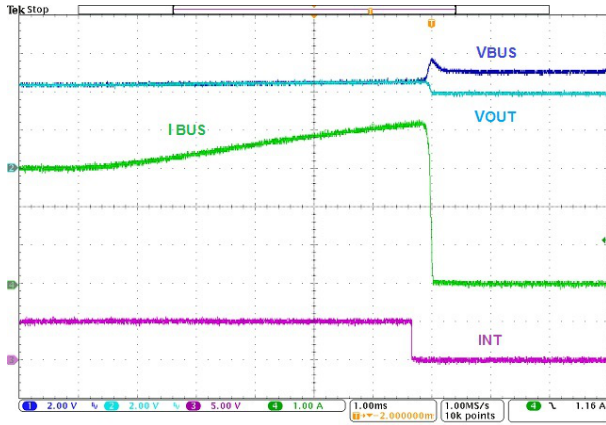

Figure 8. Switch Opening IBUS OCP Fault, $[IBUSOCP]=4\text{A}$, $[IBUSREG]=[IBATREG]=\text{max}$, T_A Current Limit Raised from 3 A to 5 A

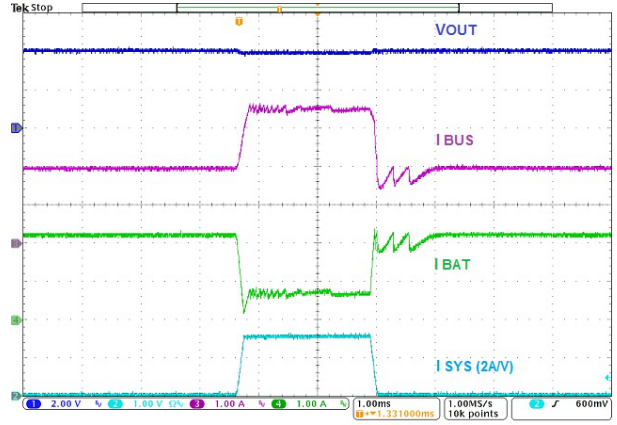

Figure 9. Load Transient Response, $[IBATREG]=2\text{A}$, $[IBUSREG]=3.5\text{A}$, T_A Configured for 5 V/5 A

Functional Specifications

Charging Bypass Switch with Regulation Mode

Overview

The FAN54161 is designed to be placed in a system that requires high current charging for a large battery. It is essentially a high current bypass switch with protection that provides a path from a charging source (adapter) to the battery directly through a low resistance path. In order to ensure safety of the battery as well as the system, the FAN54161 features multiple hardware protection mechanisms. Most of these result in the path from the charging source to the battery being opened. Examples of these are input over-voltage, over-current through the switch and reverse current.

Some of the parameters are monitored and regulated such that they are at or below a programmed threshold. This is achieved by controlling the gate of the power switch. However, this mode of operation is only meant to be used temporarily while the system controller/host reacts to this and corrects the system configuration to allow the switch to return to a bypass mode (fully-on state).

Many of the hardware protection mechanisms have I²C programmable thresholds, enable/disable controls, interrupts with masks and status bits. The product block diagram (Figure 1) provides an illustrative overview of the functionality within the FAN54161.

The FAN54161 also utilizes a fully independent charge pump based gate drive circuit to control an optional external N-channel MOSFET for an additional level of input protection from over voltage faults up to 32 V applied at the USB port.

Bypass Switch Modes of Operation

Broadly speaking, the FAN54161 has four modes of bypass switch operation.

1. **OFF:** This represents a lack of power to the FAN54161.
2. **SHUTDOWN:** Valid power is applied to one of VBUS or VOUT but the RESET_N input is asserted low. In this state, no communication with the FAN54161 is possible and the switch is forced open.
3. **STANDBY:** Valid power is applied to one of VBUS or VOUT and the RESET_N input is de-asserted high. I²C communication is enabled, but, the switch is not programmed to close.
4. **SWITCH ENABLED:** As evidenced by the name, the FAN54161 bypass switch is closed in this state. From the STANDBY state, when the SW_EN bit is written with a 1, the FAN54161 enters the SWITCH ENABLED state. In this state, the switch's gate is controlled by the control circuit of the FAN54161 to be either fully on (bypass mode) or partially on (regulation mode) based on the parameters being monitored.

Power-up and Reset (VBUS and VOUT)

When power is first applied to either VBUS or VOUT, an internal power-on reset (POR) circuit ensures the default state of all registers and circuits and keeps the switch in the OPEN state. Power for all internal logic circuits comes from the higher of VBUS and VOUT. This allows the FAN54161 to be I²C programmable even with just one of the supplies present (VBUS or VOUT).

The RESET_N pin is an active-low reset input. When the RESET_N pin is asserted low externally, the FAN54161 remains in a reset state and does not support I²C communication. The switch is forced OPEN. This corresponds to the SHUTDOWN state. The RESET_N pin being low also forces the ADC in the FAN54161 to its SHUTDOWN state.

In order to properly control and operate the FAN54161, a valid supply must be present at VBUS or VOUT and the RESET_N pin must be de-asserted (logic high state).

VUSB Power

The VUSB pin does not affect POR behavior of the FAN54161 and should be considered a completely independent power domain with respect to VBUS and VOUT.

Hardware Fault Protection

The FAN54161 features hardware safety protection monitors, some of which can cause the switch to OPEN if enabled. Other than VBUS UVLO and IC Thermal Shutdown, each hardware safety protection monitor has an independently programmable enable bit.

The high current switch is closed by setting SW_EN = 1. Before the switch closes, though, the IC is checked against the following safety protection thresholds:

- VBUS UVLO
- VBUS OVP
- VOUT OVP
- VDROPOVP
- Thermal Shutdown

If any of these safety protection monitors are enabled and the associated fault is triggered, the switch is not allowed to close and the appropriate interrupt bit is set to report the fault to the system controller/host. If no faults are triggered when SW_EN bit is set, the switch is closed.

When the switch is closed, all enabled safety protection monitors are armed. With the exception of VOREG, VBATREG, IBATREG, and IBUSREG, if any enabled fault is triggered, the switch is opened and its appropriate interrupt bit is set to 1. Refer to Figure 10 for details.

When the switch is closed, if a VOREG, VBATREG, IBATREG, or IBATREG fault is triggered, the internal logic drives the gate of the bypass switch such that the current or voltage does not exceed its regulation threshold. Additionally, its appropriate interrupt bit is set to 1. It is

FAN54161

expected that the host will take action to correct the system configuration such that the FAN54161's regulation control loop can drive the gate of the power switch to make it fully on again. Refer to Figure 11 for details.

The hardware protections for the VBUS connector and battery (T_BUS and T_BAT) are implemented through digital comparisons of a digital threshold (programmed in

the TBUSOTP and TBATOTP registers) to the ADC's converted results of these channels. Therefore, if these fault protections are enabled, it must be ensured that the ADC is enabled and programmed to convert this channel.

For additional details on Hardware Fault Protection, refer to Table 6 and Table 7.

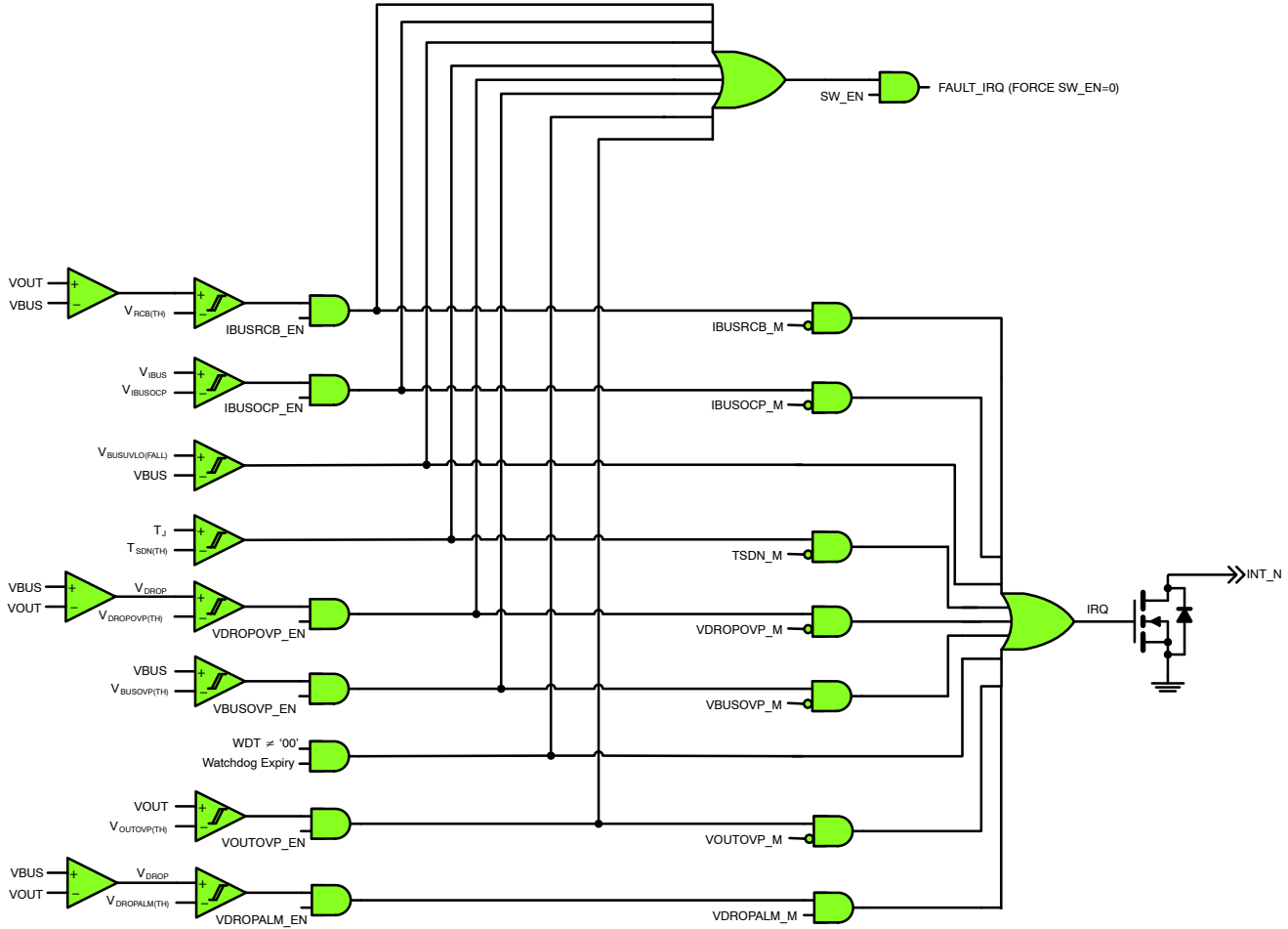

Figure 10. Hardware Protection Logic Diagram

FAN54161

Table 6. HARDWARE FAULT PROTECTION ENTRY SUMMARY

Safety Feature	Safety Mode Entry	Safety Mode Deglitch Time	Safety Mode Hardware Action	Safety Mode Register Action
VBUS OVP	$V_{BUS} > V_{BUSOVP(TH)}$	4us (OVP_DLY=0) 20us (OVP_DLY=1)	Open Bypass Switch Pull INT_N low	SW_EN=0 VBUSOVP_INT=1
VBUS UVLO Falling	$V_{BUS} < (V_{BUSUVLO(TH)} - V_{BUSUVLO(HYS)})$	4us	Open Bypass Switch Pull INT_N low	VBUSINSERT_INT=1
VDROP Alarm	$V_{DROP} > V_{DROPALM(TH)}$	4us (OVP_DLY=0) 20us (OVP_DLY=1)	Pull INT_N low	VDROPALM_INT=1
VDROP OVP	$V_{DROP} > V_{DROPOVP(TH)}$	4us (OVP_DLY=0) 20us (OVP_DLY=1)	Open Bypass Switch Pull INT_N low	SW_EN=0 VDROPOVP_INT=1
TS_BUS Overtemp	$V_{TS_BUS} < T_{BUS_TH}$ (digital comparator)	1s	Open Bypass Switch Pull INT_N low	SW_EN=0 TBUSOTP_INT=1
TS_BAT Overtemp	$V_{TS_BAT} < T_{BAT_TH}$ (digital comparator)	1s	Open Bypass Switch Pull INT_N low	SW_EN=0 TBATOTP_INT=1
Thermal Shutdown	$T_J > T_{SDN(TH)}$	800us	Open Bypass Switch Disable ADC Pull INT_N low	SW_EN=0 ADC_EN bit does not change state TSDN_INT=1
Watchdog Timer	Watchdog Timer Expired	N/A	Open Bypass Switch Pull INT_N low	SW_EN=0 Reset registers to default (except TIMER_INT) TIMER_INT=1
IBUS OCP	$I_{BUS} > I_{BUSOCP(TH)}$	50us (IBUSOCP_MODE=0)	Open Bypass Switch Pull INT_N low	SW_EN=0 IBUSOCP_INT=1
		4us (IBUSOCP_MODE=1)	1- Open Bypass Switch and enter Hiccup Mode 2- Wait 100ms then close switch 3- If $I_{BUS} < I_{BUSOCP(TH)}$ continue charging 4- If $I_{BUS} > I_{BUSOCP(TH)}$ return to top (up to 6 attempts) 5- If still OCP leave Bypass Switch open 6- Pull INT_N low	Set SW_EN=0 IBUSOCP_INT=1 (Only after 6 failed Hiccup attempts)
IBUSREG	$I_{BUS} > I_{BUSREG(TH)}$	N/A	Enter Regulation Mode Limit I_{BUS} to $I_{BUSREG(TH)}$ Pull INT_N low	IBUSREG_INT=1
IBATREG	$((V_{SRP} - V_{SRN}) / R_{SENSE}) > I_{BATREG(TH)}$	N/A	Enter Regulation Mode Limit I_{BAT} to $I_{BATREG(TH)}$ Pull INT_N low	IBATREG_INT=1
VOREG	$V_{OUT} > V_{OREG(TH)}$	N/A	Enter Regulation Mode Limit V_{OUT} to $V_{OREG(TH)}$ Pull INT_N low	VOREG_INT=1
VBATREG	$(V_{SNSP} - V_{SNSN}) > V_{BATREG(TH)}$	N/A	Enter Regulation Mode Limit $V_{SNSP} - V_{SNSN}$ to $V_{BATREG(TH)}$ Pull INT_N low	VBATREG_INT=1
VUSB OVP	$V_{USB} > V_{USBOVP(TH)}$	No Deglitch	Pull OVP_C low Pull INT_N low	VUSBOVP_INT=1 (if SW_EN=1 or ADC_EN=1)
VUSB UVLO Falling	$V_{USB} < (V_{USBUVLO(TH)} - V_{USBUVLO(HYS)})$	No Deglitch	Pull OVP_C low Pull INT_N low	VUSBINSERT_INT=1
VOUT OVP	$V_{OUT} > V_{OUTOVP(TH)}$	4us (VOUTOVP_DLY=0) 20us (VOUTOVP_DLY=1)	Open Bypass Switch Pull INT_N low	SW_EN=0 VOUTOVP_INT =1
IBUS RCB	Reverse $I_{BUS} > I_{RCB(TH)}$	10us	Open Bypass Switch Pull INT_N low	SW_EN=0 IBUSRCB_INT=1

Table 7. HARDWARE FAULT PROTECTION EXIT (RECOVERY) SUMMARY

Safety Feature	Safety Mode Exit (Recovery)	Recovery Hardware Action	Recovery Register Action
VBUS OVP	$V_{BUS} < V_{BUSOVP(TH)}$	Wait for host command	
VBUS UVLO Rising	$V_{BUS} > V_{BUSUVLO(TH)}$	switch autorecovers Pull INT_N low	VBUSINSERT_INT=1
VDROP Alarm	N/A	No Action	
VDROP OVP	$V_{DROP} < V_{DROPOVP(TH)}$	Wait for host command	
TS_BUS Overtemp	$V_{TS_BUS} > T_{BUS_TH}$ (digital comparator)	Wait for host command	
TS_BAT Overtemp	$V_{TS_BAT} > T_{BAT_TH}$ (digital comparator)	Wait for host command	
Thermal Shutdown	$T_J < T_{SDN(TH)}$	Wait for host command to close Bypass Switch; ADC auto recovery if ADC_EN=1	
Watchdog Timer	SW_EN= 1 starts watchdog	Wait for host command	
IBUS OCP	$I_{BUS} < I_{BUSOCP(TH)}$	Wait for host command	
	$I_{BUS} < I_{BUSOCP(TH)}$ During Hiccup Mode retry	Auto recovery after successful Hiccup Mode retry. OR Wait for host command if all 6 Hiccup retries fail.	Keep SW_EN=1 after successful Hiccup Mode retry. OR Set SW_EN=0 only after 6 failed Hiccup attempts.
IBUSREG	$I_{BUS} < I_{BUSREG(TH)}$	Exit Regulation Mode Bypass Switch remains closed	
IBATREG	$((V_{SRP} - V_{SRN}) / R_{SENSE}) < I_{BATREG(TH)}$	Exit Regulation Mode Bypass Switch remains closed	
VOREG	$V_{OUT} < V_{OREG(TH)}$	Exit Regulation Mode Bypass Switch remains closed	
VBATREG	$(V_{SNSP} - V_{SNSN}) < V_{BATREG(TH)}$	Exit Regulation Mode Bypass Switch remains closed	
VUSB OVP	$V_{USB} < (V_{USBOVP(TH)} - V_{USBOVP(HYS)})$	Drive OVP_C High Pull INT_N low	VBUSOVP_INT=1
VUSB UVLO Rising	$V_{USB} > V_{USBUVLO(TH)}$	Drive OVP_C High Pull INT_N low	VUSBINSERT_INT=1
VOUT OVP	$V_{OUT} < V_{OUTOVP(TH)} - V_{OUTOVP(HYS)}$	Wait for host command	
IBUS RCB	Reverse $I_{BUS} > I_{RCB(TH)}$	Wait for host command	

VBUS Input Over-Voltage Protection

When the voltage at the VBUS pin exceeds the programmed $V_{BUSOVP(TH)}$ threshold for more than $t_{BUSOVPGLTCH}$, the FAN54161 will:

1. Isolate VBUS from VOUT by opening the bypass switch
2. Reset SW_EN to 0
3. Set the VBUSOVP_INT bit to 1 and pull the INT_N pin low

A VBUS OVP fault recovery is not automatic and requires the host processor to re-enable the switch by programming SW_EN to 1. The switch will not close again until after VBUS has fallen below $V_{BUSOVP(TH)} - V_{BUSOVP(HYS)}$. Any attempts to write SW_EN to 1 during a VBUS OVP condition will result in a SW_EN self clear.

The ADC is not affected by this fault and operates according to the ADC_EN setting.

VBUS Input Under-Voltage Lockout

If the voltage applied to VBUS fails to exceed the $V_{BUSUVLO(TH)}$ threshold after an input plug-in event, the bypass switch will remain open. Setting SW_EN to 1 while $V_{BUS} < V_{BUSUVLO(TH)}$ will keep the bypass switch open. Once the VBUS voltage exceeds the $V_{BUSUVLO(TH)}$ threshold, the switch is allowed to close if SW_EN is set to 1.

From a closed position, the bypass switch will be forced open if VBUS falls below $V_{BUSUVLO(TH)} - V_{BUSUVLO(HYS)}$. In addition, the VBUSINSERT_INT interrupt bit will be set, the INT_N pin is pulled low, and the SW_EN bit will remain set.

If VOUT is available to support ADC operation during a VBUS UVLO fault, ADC will operate according to the ADC_EN setting.

VDROP Alarm Reporting

While the bypass switch is closed, if the voltage measured across the switch ($V_{BUS} - V_{OUT}$) exceeds the $V_{DROPALM(TH)}$ threshold for more than $t_{VDROPALMGLTCH}$, the FAN54161 sets the $VDROPALM_INT$ bit to 1 and pulls the INT_N pin low. This alerts the host processor that the FAN54161 is operating in a condition that may soon trigger a VDROP OVP fault which would force the switch to open. This alert feature warns the host processor to reprogram the Travel Adapter or the FAN54161's charge parameter settings to prevent a VDROP OVP fault from triggering.

VDROP Over-Voltage Protection

While the bypass switch is closed, if the voltage measured across the switch ($V_{BUS} - V_{OUT}$) exceeds the $V_{DROPOVP(TH)}$ threshold for more than $t_{VDROPGLTCH}$, the FAN54161 will:

1. Isolate V_{BUS} from V_{OUT} by opening the bypass switch
2. Reset SW_EN to 0
3. Set the $VBUSOVP_INT$ bit to 1 and pull the INT_N pin low

If a VDROP OVP fault occurs, the host processor should reprogram the FAN54161's charging parameter settings to prevent a VDROP OVP fault from reoccurring the next time the bypass switch is closed. Once the VDROP OVP fault is removed, the host processor must set SW_EN to 1 in order to close the bypass switch again. The VDROP OVP protection is disabled by default to allow the switch to close even if the difference between V_{BUS} and V_{OUT} is greater than the VDROP OVP threshold. If VDROP OVP protection is enabled before the switch is closed, care should be taken to ensure that $V_{BUS} - V_{OUT}$ is less than the VDROP OVP threshold, otherwise the VDROP OVP protection will prevent the switch from closing when writing SW_EN to 1.

The ADC is not affected by this fault and operates according to the ADC_EN setting.

Input Connector Over-Temperature Fault

The FAN54161 can monitor the temperature of the input connector with an external NTC thermistor tied from the TS_BUS pin to ground. This protection prevents bypass charging from continuing if the input connector temperature rises to a dangerous level. A TS_BUS pullup resistor tied to an externally supplied reference voltage (recommended $V_{EXTREF} = 2.4\text{ V}$) along with the NTC thermistor generate a temperature dependent voltage on the TS_BUS pin. The FAN54161's ADC must be enabled to measure and digitally compare the voltage at TS_BUS to a programmed $TBUS_TH$ threshold. The ADC's measurement of the TS_BUS voltage is monitored by the $TBUSADC$ register. A digital comparison is made between the $TBUSADC$ register contents and the $TBUS_TH$ threshold.

If the $TBUSADC$ value falls below the $TBUS_TH$ threshold for more than $t_{TBUS_TBAT_GLTCH}$, the FAN54161 will:

1. Isolate V_{BUS} from V_{OUT} by opening the bypass switch
2. Reset SW_EN to 0
3. Set the $TBUSOTP_INT$ bit to 1 and pull the INT_N pin low

There is no automatic recovery from this fault, and the host must program SW_EN to 1 to close the switch again. The ADC is not affected by this fault and operates according to the ADC_EN setting.

This digital comparison scheme does not restrict the use of NTC thermistor type or pullup resistor value. The desired $TBUS_TH$ threshold can be programmed based on the external components selected by the system designer.

Battery Over-Temperature Fault

The FAN54161 can monitor the temperature of the battery by measuring the battery pack's thermistor output pin. This protection prevents bypass charging from continuing if the battery temperature rises to a dangerous level. A TS_BAT pull-up resistor tied to an externally supplied reference voltage (recommended $V_{EXTREF} = 2.4\text{ V}$) along with the battery pack's NTC thermistor generate a temperature dependent voltage on the TS_BAT pin. The FAN54161's ADC must be enabled to measure and digitally compare the voltage at TS_BAT to a programmed $TBAT_TH$ threshold. The ADC's measurement of the TS_BAT voltage can be monitored by the $TBATADC$ register. A digital comparison is made between the $TBATADC$ register contents and the $TBAT_TH$ threshold.

If the $TBATADC$ value falls below the $TBAT_TH$ threshold for more than $t_{TBUS_TBAT_GLTCH}$, the FAN54161 will:

1. Isolate V_{BUS} from V_{OUT} by opening the bypass switch
2. Reset SW_EN to 0
3. Set the $TBATOTP_INT$ bit to 1 and pull the INT_N pin low

There is no automatic recovery from this fault, and the host must program SW_EN to 1 to close the switch. The ADC is not affected by this fault and operates according to the ADC_EN setting.

This digital comparison scheme does not restrict the use of NTC thermistor type or pullup resistor value. The desired $TBAT_TH$ threshold can be programmed based on the external components selected by the system designer.

Thermal Shutdown Protection

When the FAN54161's junction temperature exceeds the thermal shutdown threshold ($T_{SDN(TH)}$), the IC will:

1. Isolate V_{BUS} from V_{OUT} by opening the bypass switch
2. Reset SW_EN to 0
3. Set the $TSDN_INT$ bit to 1 and pull the INT_N pin low

4. Disable ADC conversion and ADC reference.

ADC enters standby state, maintains ADC_EN=1

There is no automatic recovery from this fault, and the host must program SW_EN to 1 to close the switch again.

IBUS Over Current Protection

If the input current through the bypass switch exceeds the programmed $I_{BUSOCP(TH)}$ threshold, the bypass switch will be forced open to protect the IC, battery, and system from an over-current fault condition. The IBUSOCP_MODE control bit determines the manner in which the bypass switch will react to an IBUS over-current fault event. The IC internally monitors the IBUS current through the bypass switch.

When IBUSOCP_MODE=0 and $I_{BUS} > I_{BUSOCP(TH)}$ for more than $t_{IBUSOCPGLTCH}$, the FAN54161 will:

1. Isolate VBUS from VOUT by opening the bypass switch
2. Reset SW_EN to 0
3. Set the IBUSOCP_INT bit to 1 and pulls the INT_N pin low
4. Rely on the host processor to send a SW_EN=1 command to close the switch again

When IBUSOCP_MODE=1 and $I_{BUS} > I_{BUSOCP(TH)}$ for more than $t_{IBUSOCPGLTCH}$, the FAN54161 will:

1. Enter the Hiccup Mode cycle and isolate VBUS and VOUT by opening the bypass switch
2. Maintain SW_EN =1 during hiccup mode retry
3. Wait 100 ms, close the bypass switch to check if the IBUS over-current condition is removed
- ◆ If the IBUS over-current condition is removed, the bypass switch will remain closed, keep SW_EN=1, and exit the Hiccup Mode cycle
- ◆ If the IBUS over-current condition remains, the Hiccup Mode cycle (starting from step 1) is repeated up to 6 more times
- ◆ If the IBUS over-current condition remains after 6 attempts, the IBUSOCP_INT interrupt bit is set to 1 and the INT_N pin is pulled low. The bypass switch is forced open and SW_EN is reset to 0 and the host processor must set SW_EN=1 to close the switch again

The ADC is not affected by this fault and operates according to the ADC_EN setting.

Watchdog Timer

To prevent unattended charging that may potentially damage the battery and/or system while the bypass switch is closed, the FAN54161 uses a watchdog timer as an additional layer of protection. The WDT control bits set the watchdog timer period and whether the watchdog timer protection will be enabled. If enabled, the watchdog timer starts when SW_EN is programmed to 1. To clear the watchdog timer, the host processor must execute an I²C read or write command to any of the FAN54161's I²C registers. When changing the setting of the watchdog timer

in REG 0x06h[3:2], the new watchdog setting will not take effect until the next I²C read/write transaction.

If the host processor fails to clear the watchdog timer and allows the watchdog timer to expire, the FAN54161 will:

1. Isolate VBUS from VOUT by opening the bypass switch
2. Reset all registers to their default values
3. Set the TIMER_INT bit to 1 and pull the INT_N pin low

VOUT Over-Voltage Protection

If the voltage applied to the VOUT pin exceeds the programmed $V_{OUTOVP(TH)}$ threshold for more than $t_{VOUTOVPGLTCH}$, the FAN54161 will:

1. Isolate VBUS from VOUT by opening the bypass switch
2. Reset SW_EN to 0
3. Set the VOUTOVP_INT bit to 1 and pull the INT_N pin low

If a VOUT OVP fault occurs, the host processor should reprogram the FAN54161's charge parameter settings to prevent a VOUT OVP fault from reoccurring the next time the bypass switch is closed. Once the VOUT OVP fault is removed, the host processor must set SW_EN to 1 in order to close the bypass switch again. The switch will not close again until after VOUT has fallen below $V_{OUTOVP(TH)} - V_{OUTOVP(HYS)}$.

The VOUT over-voltage protection feature serves as an additional layer of protection in case the VOREG CV regulation loop is not fast enough to respond to a VOUT over-voltage fault, or if VOREG regulation is disabled.

The ADC is not affected by this fault and operates according to the ADC_EN setting.

IBUS Reverse Current Protection

If the reverse current through the bypass switch (from VOUT to VBUS) rises above the programmed $I_{RCB(TH)}$ threshold, the bypass switch will be forced open to prevent excessive reverse current flow from the battery back to the input source. The IRCB control bit sets the $I_{RCB(TH)}$ reverse current threshold (0 = 100 mA, 1 = 3 A). The direction of $I_{RCB(TH)}$ is defined as current flow from VOUT to VBUS. The IC internally monitors the IBUS current through the bypass switch.

When the current from VOUT to VBUS rises above $I_{RCB(TH)}$ for more than the $t_{RCBGLTCH}$ deglitch time, the FAN54161 will:

1. Isolate VBUS from VOUT by opening the bypass switch
2. Reset SW_EN to 0
3. Set the IBUSRCB_INT bit to 1 and pull the INT_N pin low
4. Rely on the host processor to send a SW_EN=1 command to close the switch again

The ADC is not affected by this fault and operates according to the ADC_EN setting.

VFAIL Detection

In bypass charging applications, a failure of the bypass charging switch (however, this is rare) could result in the travel adapter output being directly connected to the battery pack which can cause a potentially dangerous system fault. A V_{FAIL} comparator monitors the voltage at PMID while the bypass switch is open to detect the presence of a leakage path from VBUS to PMID (when TA is attached) or VOUT to PMID (when battery is connected) which would indicate a failure in the bypass charging FET. During VFAIL detection, a R_{FAIL} pulldown resistor is connected to PMID and a comparator checks if the PMID voltage exceeds the VFAIL threshold. R_{FAIL} will be disconnected from PMID anytime the bypass switch is enabled to avoid power consumption during bypass charging.

If the detection determines that $V_{PMID} > V_{FAIL}$ for more than t_{VFAIL_GLTCH} , the FAN54161 will:

1. Set the VFAIL_INT bit to 1 and pull the INT_N pin low

A VFAIL interrupt alerts the host that damage to the bypass charging FET has occurred. The host can then alert the system bypass charging controller to clamp the travel adapter's output voltage to the battery pack's float voltage to prevent an overcharge of the battery. Additionally, the host can alert the end user that the portable device is damaged and should be returned for repair.

If $V_{FAIL_EN}=1$, VFAIL detection is momentarily activated when:

1. SW_EN is set from 0 to 1, while $ADC_EN=0$ and $RESET_N=1$. VFAIL detection occurs before the charge pump gate drive turns on the bypass charging FET but after the main bandgap reference is enabled
2. ADC_EN is set from 0 to 1, while $SW_EN=0$ and $RESET_N=1$

Regulation Loops

Figure 11 illustrates the logic that causes the FAN54161 to enter regulation mode.

Either of the following four fault protections being triggered can cause the switch to operate in regulation mode as follows:

1. If the voltage at VOUT exceeds $V_{OREG(TH)}$, and $V_{OREG_EN}=1$, the bypass switch will be regulated such that VOUT is limited to $V_{OREG(TH)}$.
2. If the voltage across SNSP and SNSN exceeds $V_{BATREG(TH)}$, and $V_{BATREG_EN}=1$, the bypass switch will be regulated such V_{BAT} is limited to $V_{BATREG(TH)}$.
3. If I_{BAT} (sensed as a voltage across SRP and SRN) exceeds $I_{BATREG(TH)}$, and $I_{BATREG_EN}=1$, the bypass switch will be regulated such that I_{BAT} is limited to $I_{BATREG(TH)}$.
4. If I_{BUS} (from VBUS to VOUT) exceeds $I_{BUSREG(TH)}$, and $I_{BUSREG_EN}=1$, the bypass switch will be regulated such that I_{BUS} is limited to $I_{BUSREG(TH)}$.

It must be noted that the switch essentially becomes more resistive during regulation mode. This will cause more power dissipation in the switch and a greater likelihood of the junction temperature reaching or exceeding the shutdown threshold $T_{SDN(TH)}$. Therefore it is imperative for the system host controller to update the system configuration such that none of the above four monitors are triggered. This can be done by increasing the thresholds in the FAN54161 or changing other external system parameters (ex: adapter voltage or current limit).

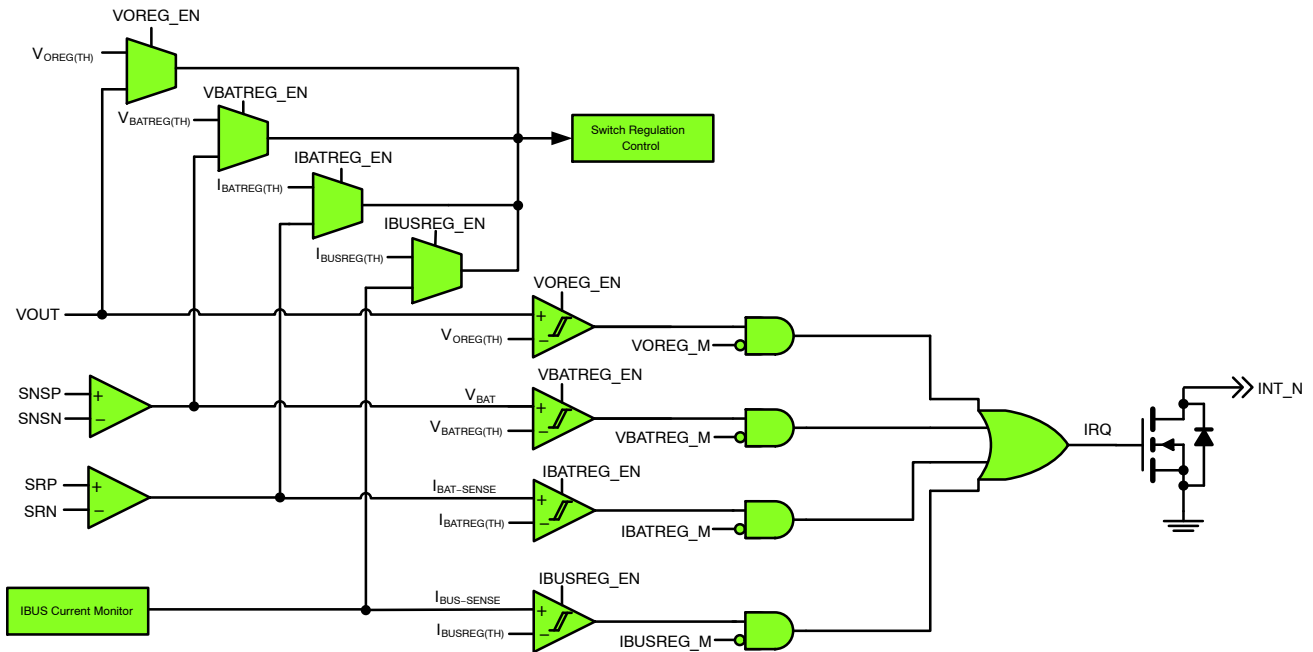

Figure 11. Switch Regulation Mode Entry Diagram

External N-Channel MOSFET Gate Control (OVP_C)

The FAN54161 utilizes an additional protection scheme to protect the bypass switch from over voltage faults up to 32 V. Integrating a charge pump based gate control circuit, the FAN54161 can sense an over voltage fault applied to the VUSB input pin while controlling an external N-channel MOSFET to isolate the over voltage fault condition from the bypass switch’s VBUS input pin. The VUSB pin serves as the power supply input for the charge pump gate control and also as the sense pin for an VUSB over voltage fault. Connect an at least 32 V rated N-channel MOSFET with its source to VBUS, drain to VUSB, and gate to OVP_C.

The OVP_C gate control pin will enable the external N-channel MOSFET when $V_{USBVLO(TH)} < V_{USB} < V_{USBOVP(TH)}$. If $V_{USB} < V_{USBVLO(TH)}$ or $V_{USB} > V_{USBOVP(TH)}$, the OVP_C gate control will disable the external N-channel MOSFET and set the appropriate VUSB fault interrupt.

The OVP_C gate control and VUSB OVP detection circuits operate completely independent of the bypass switch and are solely powered by the VUSB input. If an external N-channel MOSFET is not used, the VUSB pin must be left floating and the OVP_C pin must be connected to VBUS (preferred) or can be left floating. This will not affect bypass switch operation.

Interrupt Mechanism

Figures 10 and 11 illustrate the interrupt and mask architecture that drives the INT_N pin.

The FAN54161 features interrupt flag and interrupt mask registers that contain interrupt bits for all the fault protection monitors, in addition to interrupt flags for other events. All interrupt bits are clear-on-read. When an interrupt flag bit

is set in the INT1, INT2 or INT3 register and its corresponding mask bit is a 0 (unmasked), the INT_N pin is asserted low. For proper interrupt reporting, the ADC must be enabled or the switch closed.

Analog to Digital Converter

Feature Summary

The integrated 10-bit Analog-to-Digital Converter in the FAN54161 comprises the following features:

1. Fully Differential Input high-accuracy SAR ADC
2. Up to 9 channels that can be independently configured for conversion
 - (i) Hardware protection based on digitized result of connector (VBUS) temperature and Battery temperature
3. Single-shot or Continuous conversion
4. Fast throughput
 - (i) 54 μ s conversion time for a single channel without averaging
 - (ii) 1166 μ s conversion time for all 9 channels with 16 samples per channel
5. Configurable averaging
 - (i) Enable/Disable for all channels
 - (ii) Programmable options of 8- or 16-sample average per channel
6. Post-processed Output Format
 - (i) ADC output format removes the need for host post-processing
7. Fully configurable through digital I²C interface
 - (i) Interrupt based indication of conversion completion

ADC Power Supply

The ADC operation is primarily focused during charging when a valid input is present at VBUS. However, the ADC can operate with a valid supply on VOUT (possibly from the battery) even without a valid VBUS input. For reliable operation, the voltage at VBUS or VOUT should be no less than 3.1 V.

The ADC does not restrict the conversion of the VBUS or IBUS channels when a valid VBUS is not present. If the channel is enabled and conversion is started, the ADC will report the result of whatever the voltage and currents are for VBUS and IBUS which would typically be zero.

ADC Channel Summary

Table 8 demonstrates all the possible channels that the ADC in the FAN54161 can be configured to convert.

1. Every signal is processed through an analog pre-scalar circuit that converts the incoming signal range in volts, amps or °C to the ADC input range.

2. IBAT has special considerations since it measures current through a sense resistor that is part of the external application circuit. Depending on the R_{sense} value used, RSENSE should be programmed for the correct ADC reading on IBAT.
3. T_BUS and T_BAT are meant for measuring external NTC voltages pulled up externally to 2.4V. However, they can also be used as general purpose inputs that conform to the same signal range shown in the table.
4. The accuracy referred to the input is based on error analysis of the entire signal chain comprising the pre-scalars and the ADC. Refer to the Electrical Characteristics table of the ADC for the referenced parameters.

Table 8. ADC CHANNEL SUMMARY

Channel #	Name	Signal Range (V, A, °C)	LSB Step (mV, mA, °C)	Input Referred Accuracy (mV, mA, °C) at room temp
0	VBUS	0.3 to 6.1	7.3	11
1	VOUT	0 to 5.0	5.3	14
2	VBAT (charging)	2.5 to 5.0	5.3	14
	VBAT (discharging)	2.5 to 5.0	5.3	11
3	VDROP	0 to 1.0	2.9	6
4	IBUS	0 to 7.0	14.6	34
5	IBAT	-7.0 to +7.0	14.6	73
6	T_BUS	0 to 2.4	2.9	12
7	T_BAT	0 to 2.4	2.9	12
8	T_DIE	25 to 150	0.067	1

ADC Configuration

There are two registers, ADC_CHANNEL and ADC_CONTROL, which are used to configure and control the ADC. All 9 channels have independent enable bits which reside in these registers.

The ADC_CONTROL register and ADC_CHANNEL register values should not be reprogrammed when the ADC is performing a conversion.

ADC Control

The ADC can be configured to perform a one-shot conversion or perform continuous conversion by setting the ADC_RATE bit to 1.

An ADC conversion is initiated by setting the ADC_EN bit to 1. Once initiated, the ADC will convert the channels enabled for conversion according to the average mode selected (programmed by AVG_EN and SAMPLES). The enabled ADC channels are converted in order (LSB to MSB of ADC_CHANNEL register), followed by the ICTEMP bit in the ADC_CONTROL register.

- If the ADC_RATE bit is 0 (one-shot conversion), the ADC stores the results in the appropriate registers and sets the ADC_DONE interrupt bit. The ADC_EN bit is cleared to 0 after the conversion of all channels is complete.
- If the ADC_RATE bit is 1 (continuous conversion), the ADC stores the results in the appropriate registers and immediately begins a new conversion. In order to stop conversions, it is recommended to set the ADC_RATE bit to 0. This will ensure a complete conversion where the ADC_DONE interrupt bit is set and the ADC_EN bit is cleared to 0 similar to a normal one-shot conversion.
 - ◆ Writing a 0 to the ADC_EN bit during continuous conversion is not recommended. This will immediately stop conversion without completing even the currently scheduled channel's conversion. The ADC_DONE interrupt bit will not be set.

ADC Output Format

Each channel of the ADC has a dedicated pair of registers (an MSB register and an LSB register) where the input referred results are stored after a conversion is completed. Each pair is used to report the ADC's converted result and polarity in binary format.

Example 1: if the IBAT current is 5 A, the ADC's output in 10-bit format is converted back to represent 5 A = 5000 mA = 0b0000100111000100. This value is stored in the registers IBAT_MSB and IBAT_LSB.

If IBAT is -5 A instead, the final result stored in 0b1000100111000100.

ADC Result Access

The required sequence for reading the results of any ADC channel is to first read its MSB register followed by its LSB register.

If the ADC is in one-shot conversion mode (ADC_RATE = 0), the host should issue I²C read commands to any of the results registers (REG 0x13 to 0x23) after the ADC_DONE interrupt is issued.

If the ADC is in continuous conversion mode (ADC_RATE = 1), the host can issue I²C read commands to any of the results registers (REG 0x13 to 0x23) even while the ADC is performing conversions and storing results in these registers.

ADC Based Over-temperature Protection

The two pins TS_BUS and TS_BAT are used to measure temperature of the VBUS connector and the battery respectively, by measuring voltage of an external NTC thermistor. This thermistor has an external pull-up to a 2.4 V supply. The ADC also converts the signal on these two pins to 10-bit results and stores them in the registers TBUS_MSB, TBUS_LSB, TBAT_MSB and TBAT_LSB respectively. These results are used in the following manner described to provide hardware protection for over-temperature of the VBUS connector or battery. The logic to explain this is illustrated in Figure 12.

- There are two registers to configure a digital over-temperature threshold called TBUSOTP and TBATOTP respectively.
- When the voltage measured by the ADC on TS_BUS or TS_BAT drops below the value in the registers TBUSOTP or TBATOTP respectively, the over-temperature hardware protection is triggered.
- If TBUSOTP_EN or TBATOTP_EN bits in the PROTECT_EN register are set to 1, and in addition, the corresponding TBUSADC_EN or TBATADC_EN bits are enabled, then the TBUSOTP or TBATOTP fault being triggered will result in the switch of the FAN54161 to be opened.
- This also causes the interrupt bit TBUSOTP_INT or TBATOTP_INT to be set accordingly, and if unmasked, will assert the INT_N pin low.

Example 1: TBUSOTP_EN = 1 and TBUSADC_EN = 1
If the output of the ADC for the TBUS channel (TBUS_MSB, TBUS_LSB) drops below the value programmed in TBUSOTP, the switch will open and TBUSOTP_INT will be set.

Example 2: TBATOTP_EN = 1 and TBATADC_EN = 0
If the output of the ADC for the TBAT channel (TBAT_MSB, TBAT_LSB) drops below the value programmed in TBATOTP, the switch will not open and the TBATOTP_INT will not be set.

Although the value in the ADC result registers exceeds that in the threshold register, since the ADC is not enabled to convert that channel, the result cannot be trusted and hence is not allowed to control the switch.

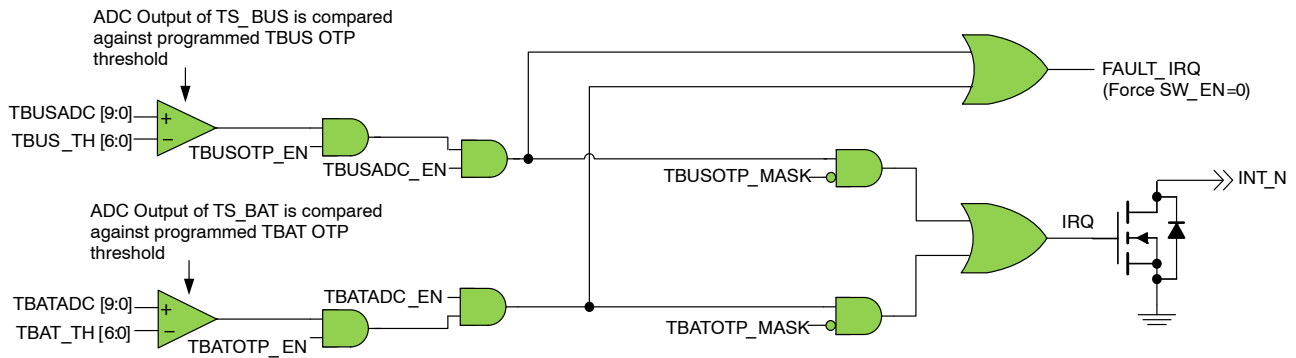

Figure 12. ADC Monitored Hardware Protection Diagram

I²C Interface

Introduction

The FAN54161 I²C specification is compatible with the Standard, Fast Mode, Fast Mode+ and High Speed Mode specifications.

- The FAN54161’s SCL pin is an input and the SDA pin is an open–drain bi–directional output.
- The SDA pin pulls the the SDA bus low only when data is being read out from the FAN54161 or during the “acknowledge” bit duration of a valid I²C transaction.
- All data is shifted in MSB first (Bit 7).
- The FAN54161 supports single register read and write transactions as well as multiple register read transactions.

Selectable I²C Slave Address

The ADR pin sets the 7–bit I²C slave address of the device. The FAN54161 can be set for three unique slave addresses. To set the 7–bit slave address to 0x65h, tie the ADR pin to a valid supply with a 10 kOhm pullup. To set the slave address to 0x66h, float the ADR pin. To set the slave address to 0x67h, connect the ADR pin to ground.

Note that the ADR pin logic state is checked in order to set the corresponding I²C address during power–up from previous state of no power supply or when the RESET_N pin is toggled from LOW to HIGH.

Table 9. I²C Slave Address when ADR = High (0x65h, 7 bit)

A6	A5	A4	A3	A2	A1	A0	R/W
1	1	0	0	1	0	1	X

Table 10. I²C Slave Address when ADR = Float (0x66h, 7 bit)

A6	A5	A4	A3	A2	A1	A0	R/W
1	1	0	0	1	1	0	X

Table 11. I²C Slave Address when ADR = Low (0x67h, 7 bit)

A6	A5	A4	A3	A2	A1	A0	R/W
1	1	0	0	1	1	1	X

Bus Timing

Data is transferred when SCL is LOW. Data is clocked in on the rising edge of SCL. Typically data transitions at or after the subsequent falling edge of SCL in order to provide ample setup time for the next data bit to be ready before the subsequent rising edge of SCL.

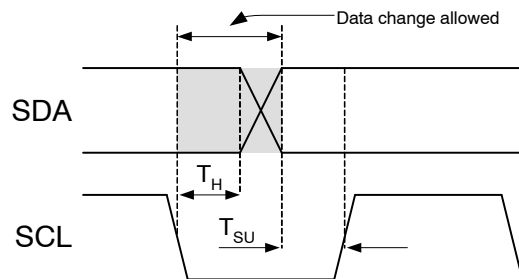

Figure 13. Data Transfer Timing

The idle state of the I²C bus is SDA and SCL both in the high state. A valid transaction begins with a START condition which occurs when SDA transitions from HIGH to LOW when SCL remains HIGH.

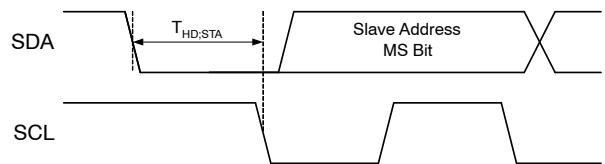

Figure 14. I²C Start Condition

A valid transaction ends with a STOP condition which occurs when SDA transitions from LOW to HIGH when SCL remains HIGH.

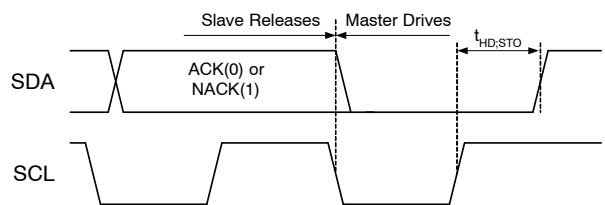

Figure 15. I²C Stop Condition

FAN54161

A REPEATED START condition is functionally equivalent to a STOP condition followed immediately by a START condition.

Read and Write Transactions

Single Register Write Transaction

The FAN54161 supports the following protocol to write to a single register at a time.

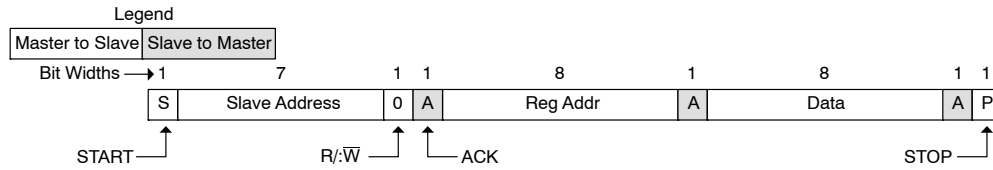

Figure 16. Single Register Write Transaction

Single Register Read Transaction

The FAN54161 supports the following protocol to read from a single register at a time.

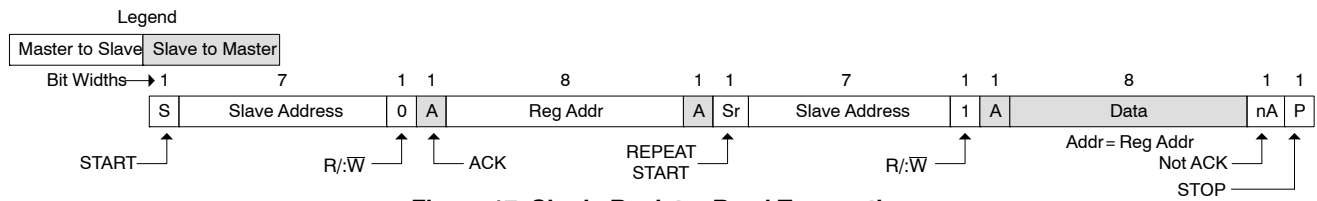

Figure 17. Single Register Read Transaction

Multiple Register Read Transaction

The FAN54161 supports the following protocol to read from multiple registers at a time.

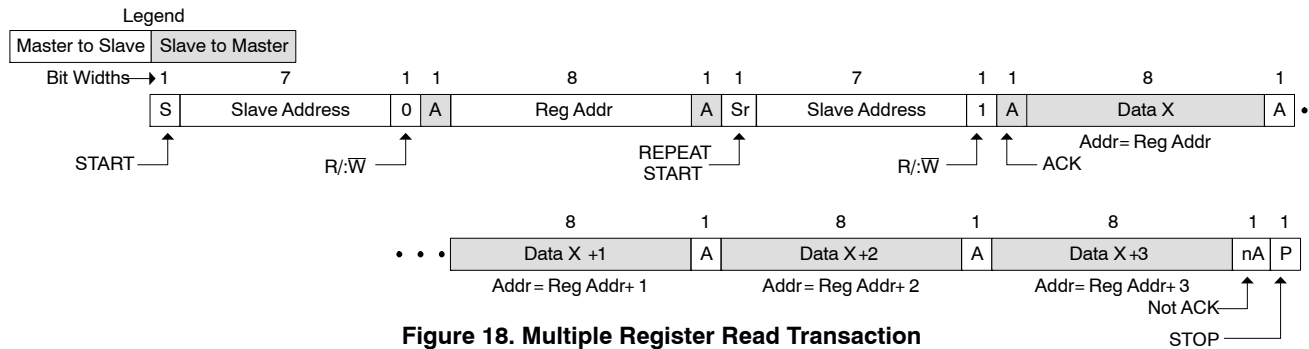

Figure 18. Multiple Register Read Transaction

FAN54161

PCB Layout and Component Placement

Proper PCB layout and component placement will provide an optimal thermal relief path for the FAN54161 IC as well as a low impedance charging path. The VBUS (A6 through G6) and VOUT (A3/A4 through G3/G4) balls, and the associated charging path, carry the majority of the charging current when the FAN54161 switch is closed.

Layout recommendations:

- Increase copper weight to greater than 1 oz, if possible.
- Use large as possible copper area for both VBUS and VOUT planes and ensure that copper floods the landing pads of all the VBUS and VOUT balls.
- Place via-in-pad on all VBUS and VOUT landing pads and mirror the top layer copper to the bottom layer for an additional thermal relief path.
 - ♦ Follow the recommended placement for CBUS and COUT shown in Figure 19.
- Place a floating copper plane on PMID (A5 through G5) to provide an additional thermal relief path.
 - ♦ Place via-in-pad on all PMID landing pads and mirror the top layer copper to the bottom layer for an additional thermal relief path.

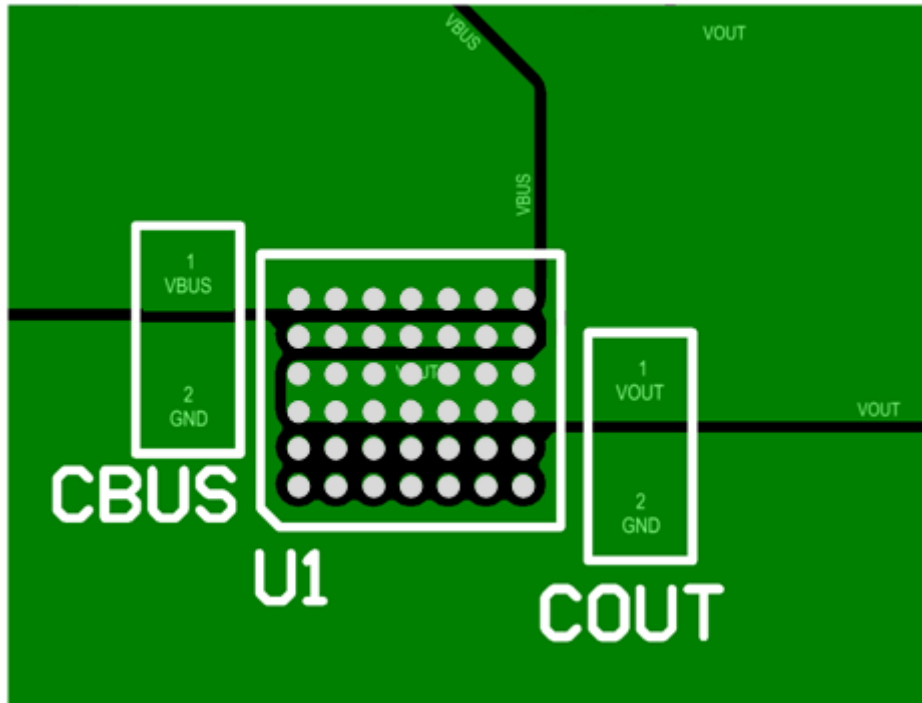

Figure 19. VBUS and VOUT Copper Top Layer Routing

I²C Registers and Bit Descriptions

Register Map

Register		Bit Name							
Name	Adr	7	6	5	4	3	2	1	0
IC INFO	00h	Reserved	Reserved	REV			PN		
INT1 MASK	01h	VBUSOVP_M	IBUSREG_M	VBATREG_M	IBATREG_M	VOREG_M	TBUSOTP_M	TBATOTP_M	IBUSRCB_M
INT2 MASK	02h	Reserved	ADCDONE_M	VDROPALM_M	VDROPOVP_M	VBUSINSERT_M	VBATINSERT_M	TSDN_M	IBUSOCP_M
INT1	03h	VBUSOVP_INT	IBUSREG_INT	VBATREG_INT	IBATREG_INT	VOREG_INT	TBUSOTP_INT	TBATOTP_INT	IBUSRCB_INT
INT2	04h	Reserved	ADCDONE_INT	VDROPALM_INT	VDROPOVP_INT	VBUSINSERT_INT	VBATINSERT_INT	TSDN_INT	IBUSOCP_INT
PROTECT_EN	05h	VBUSOVP_EN	IBUSREG_EN	VBATREG_EN	IBATREG_EN	VOREG_EN	TBUSOTP_EN	TBATOTP_EN	VBUSPD_EN
SW_CONTROL	06h	VDROPOVP_EN	VDROPALM_EN	RSENSE	SW_EN	WDT		IRCB	REG_RST
ADC_CONTROL	07h	ICTEMPADC_EN	Reserved	Reserved	Reserved	ADC_EN	ADC_RATE	AVG_EN	SAMPLES
ADC_CHANNEL	08h	VBUSADC_EN	IBUSADC_EN	VOUTADC_EN	VDROPADC_EN	VBATADC_EN	IBATADC_EN	TBUSADC_EN	TBATADC_EN
PROT_DELAY	09h	IBUSOCP_TH				Reserved	Reserved	IBUSOCP_MODE	OVP_DLY
VBUSOVP	0Ah	Reserved	VBUSOVP_TH						
VOREG	0Bh	Reserved	VOREG						
VDROPOVP	0Ch	VDROPOVP_TH							
VDROP_ALM	0Dh	VDROP_ALM							
VBATREG	0Eh	Reserved	VBATREG						
IBATREG	0Fh	Reserved	IBATREG						
IBUSREG	10h	IBUSREG							
TBUSOTP	11h	Reserved	TBUS_TH						
TBATOTP	12h	Reserved	TBAT_TH						
VBUS_MSB	13h	Reserved	Reserved	Reserved	VBUSADC_MSB				
VBUS_LSB	14h	VBUSADC_LSB							
IBUS_MSB	15h	Reserved	Reserved	Reserved	IBUSADC_MSB				
IBUS_LSB	17h	IBUSADC_LSB							
VOUT_MSB	17h	Reserved	Reserved	Reserved	VOUTADC_MSB				
VOUT_LSB	18h	VOUTADC_LSB							
VDROP_MSB	19h	Reserved	Reserved	Reserved	Reserved	Reserved	Reserved	VDROPADC_MSB	
VDROP_LSB	1Ah	VDROPADC_LSB							
VBAT_MSB	1Bh	Reserved	Reserved	Reserved	VBATADC_MSB				
VBAT_LSB	1Ch	VBATADC_LSB							
IBAT_MSB	1Dh	IBATADC_POL	Reserved	Reserved	IBATADC_MSB				
IBAT_LSB	1Eh	IBATADC_LSB							
TBUS_MSB	1Fh	Reserved	Reserved	Reserved	Reserved	TBUSADC_MSB			
TBUS_LSB	20h	TBUSADC_LSB							
TBAT_MSB	21h	Reserved	Reserved	Reserved	Reserved	TBATADC_MSB			
TBAT_LSB	22h	TBATADC_LSB							
ICTEMP_ADC	23h	ICTEMPADC							
CONTROL1	50h	TJSHDN		Reserved	VOUTOVP_DLY	VOUTOVP_EN	VFAIL_EN	IBUSRCB_EN	IBUSOCP_EN
CONTROL2	51h	Reserved	VOUTOVP_TH						
INT3 MASK	52h	Reserved	Reserved	Reserved	Reserved	VOUTOVP_M	VFAIL_M	VUSBOVP_M	VUSBINSERT_M
INT3	53h	Reserved	Reserved	Reserved	TIMER_INT	VOUTOVP_INT	VFAIL_INT	VUSBOVP_INT	VUSBINSERT_INT
STATUS1	54h	VOREG_ST	VBATREG_ST	IBATREG_ST	IBUSREG_ST	VBUSINSERT_ST	VBATINSERT_ST	Reserved	VUSBINSERT_ST

FAN54161

Bit Descriptions

Default values are in bold text. Default values are with $V_{BAT} = 3.8\text{ V}$ and $V_{BUS} = \text{open}$.

IC INFO				Register Address = 00h	Default = 0000 1010
Bit	Name	Default	Type	Description	
7	Reserved	0	Read	Reserved. Always reads 0.	
6	Reserved	0	Read	Reserved. Always reads 0.	
5:3	REV	001	Read	This indicates the revision number of the IC.	
2:0	PN	010	Read	This indicates the part number of the IC.	

INT1 MASK				Register Address = 01h	Default = 0000 0000
Bit	Name	Default	Type	Description	
7	VBUSOVP_M	0	R/W	This is the interrupt mask for a VBUS over voltage fault. Reset condition: RESET_N falling; REG_RST=1; Watchdog Timer Expiry	
6	IBUSREG_M	0	R/W	This is the interrupt mask for an IBUS over current regulation event where the switch operates in regulation mode to limit the input current to the IBUSREG setting. Reset condition: RESET_N falling; REG_RST=1; Watchdog Timer Expiry	
5	VBATREG_M	0	R/W	This is the interrupt mask for the VBAT CV regulation loop. Reset condition: RESET_N falling; REG_RST=1; Watchdog Timer Expiry	
4	IBATREG_M	0	R/W	This is the interrupt mask for the IBAT CC regulation loop. Reset condition: RESET_N falling; REG_RST=1; Watchdog Timer Expiry	
3	VOREG_M	0	R/W	This is the interrupt mask for the VOUT CV regulation loop. Reset condition: RESET_N falling; REG_RST=1; Watchdog Timer Expiry	
2	TBUSOTP_M	0	R/W	This is the interrupt mask for a T_BUS over temperature fault. Reset condition: RESET_N falling; REG_RST=1; Watchdog Timer Expiry	
1	TBATOTP_M	0	R/W	This is the interrupt mask for a T_BAT over temperature fault. Reset condition: RESET_N falling; REG_RST=1; Watchdog Timer Expiry	
0	IBUSRCB_M	0	R/W	This is the interrupt mask for an IBUS reverse current fault. Reset condition: RESET_N falling; REG_RST=1; Watchdog Timer Expiry	

INT2 MASK				Register Address = 02h	Default = 0000 0000
Bit	Name	Default	Type	Description	
7	Reserved	0	Read	Reserved. Always reads 0.	
6	ADCDONE_M	0	R/W	This is the interrupt mask for a completed ADC conversion. Reset condition: RESET_N falling; REG_RST=1; Watchdog Timer Expiry	
5	VDROPALM_M	0	R/W	This is the interrupt mask for when VDROP rises above its alarm threshold. Reset condition: RESET_N falling; REG_RST=1; Watchdog Timer Expiry	
4	VDROPOVP_M	0	R/W	This is the interrupt mask for when VDROP rises above its OVP threshold. Reset condition: RESET_N falling; REG_RST=1; Watchdog Timer Expiry	
3	VBUSINSERT_M	0	R/W	This is the interrupt mask for when VBUS rises above $V_{BUSUVLO(TH)}$ or falls below $V_{BUSUVLO(TH)} - V_{BUSUVLO(HYS)}$. Reset condition: RESET_N falling; REG_RST=1; Watchdog Timer Expiry	
2	VBATINSERT_M	0	R/W	This is the interrupt mask for when V_{SNSP} rises above $V_{BATINSERT(TH)}$ or falls below $V_{BATINSERT(TH)} - V_{BATINSERT(HYS)}$. Reset condition: RESET_N falling; REG_RST=1; Watchdog Timer Expiry	
1	TSDN_M	0	R/W	This is the interrupt mask for an IC thermal shutdown fault. Reset condition: RESET_N falling; REG_RST=1; Watchdog Timer Expiry	
0	IBUSOCP_M	0	R/W	This is the interrupt mask for an IBUS over current event where the IBUSOCP threshold is exceeded. Reset condition: RESET_N falling; REG_RST=1; Watchdog Timer Expiry	

FAN54161

INT1				Register Address = 03h	Default = 0000 0000
Bit	Name	Default	Type	Description	
7	VBUSOVP_INT	0	R/CLR	This interrupt bit is set when the VBUS voltage exceeds $V_{BUSOVP(TH)}$. Reset condition: RESET_N falling; REG_RST=1; Watchdog Timer Expiry	
6	IBUSREG_INT	0	R/CLR	This interrupt bit is set when IBUS CC loop operates the switch in regulation mode to limit I_{BUS} to $I_{BUSREG(TH)}$. Reset condition: RESET_N falling; REG_RST=1; Watchdog Timer Expiry	
5	VBATREG_INT	0	R/CLR	This interrupt bit is set when the VBAT CV loop is operating the switch in regulation mode to limit $(V_{SNSP}-V_{SNSN})$ to $V_{BATREG(TH)}$. Reset condition: RESET_N falling; REG_RST=1; Watchdog Timer Expiry	
4	IBATREG_INT	0	R/CLR	This interrupt bit is set when the IBAT CC loop is operating the switch in regulation mode to limit I_{BAT} to $I_{BATREG(TH)}$. Reset condition: RESET_N falling; REG_RST=1; Watchdog Timer Expiry	
3	VOREG_INT	0	R/CLR	This interrupt bit is set when the VOUT CV loop is operating the switch in regulation mode to limit V_{OUT} to $V_{OREG(TH)}$. Reset condition: RESET_N falling; REG_RST=1; Watchdog Timer Expiry	
2	TBUSOTP_INT	0	R/CLR	This interrupt bit is set when the temperature of the T_BUS NTC thermistor has exceeded the T_BUS over temperature threshold. The ADC must have the TBUSOTP channel active to trigger this interrupt. Reset condition: RESET_N falling; REG_RST=1; Watchdog Timer Expiry	
1	TBATOTP_INT	0	R/CLR	This interrupt bit is set when the temperature of the T_BAT NTC thermistor has exceeded the T_BAT over temperature threshold. The ADC must have the TBATOTP channel active to trigger this interrupt. Reset condition: RESET_N falling; REG_RST=1; Watchdog Timer Expiry	
0	IBUSRCB_INT	0	R/CLR	This interrupt bit is set when the current from VOUT to VBUS exceeds $I_{RCB(TH)}$. Reset condition: RESET_N falling; REG_RST=1; Watchdog Timer Expiry	

INT2				Register Address = 04h	Default = 0000 0000
Bit	Name	Default	Type	Description	
7	Reserved	0	Read	Reserved. Always reads 0.	
6	ADCDONE_INT	0	R/CLR	This interrupt bit is set when ADC conversion is complete in one-shot mode only Reset condition: RESET_N falling; REG_RST=1; Watchdog Timer Expiry	
5	VDROPALM_INT	0	R/CLR	This interrupt bit is set when the VDROP voltages exceeds $V_{DROPALM(TH)}$. Reset condition: RESET_N falling; REG_RST=1; Watchdog Timer Expiry	
4	VDROPOVP_INT	0	R/CLR	This interrupt bit is set when the VDROP voltages exceeds $V_{DROPOVP(TH)}$. Reset condition: RESET_N falling; REG_RST=1; Watchdog Timer Expiry	
3	VBUSINSERT_INT	0	R/CLR	This interrupt bit is set when the ADC is enabled and VBUS voltage rises above $V_{BUSUVLO(TH)}$ or falls below $V_{BUSUVLO(TH)} - V_{BUSUVLO(HYS)}$. This interrupt is edge triggered. Reset condition: RESET_N falling; REG_RST=1; Watchdog Timer Expiry	
2	VBATINSERT_INT	0	R/CLR	This interrupt bit is set when the ADC is enabled and V_{SNSP} rises above $V_{BATINSERT(TH)}$ or falls below $V_{BATINSERT(TH)} - V_{BATINSERT(HYS)}$. This interrupt is edge triggered. Reset condition: RESET_N falling; REG_RST=1; Watchdog Timer Expiry	
1	TSDN_INT	0	R/CLR	This interrupt bit is set when the die temperature exceeds $T_{SDN(TH)}$. Reset condition: RESET_N falling; REG_RST=1; Watchdog Timer Expiry	
0	IBUSOCP_INT	0	R/CLR	This interrupt bit is set when the IBUS current exceeds $I_{BUSOCP(TH)}$. Reset condition: RESET_N falling; REG_RST=1; Watchdog Timer Expiry	

FAN54161

PROTECT_EN				Register Address = 05h	Default = 1111 1110
Bit	Name	Default	Type	Description	
7	VBUSOVP_EN	1	R/W	A 1 enables VBUS OVP protection. Reset condition: RESET_N falling; REG_RST=1; Watchdog Timer Expiry	
6	IBUSREG_EN	1	R/W	A 1 enables IBUS constant current regulation capability. Reset condition: RESET_N falling; REG_RST=1; Watchdog Timer Expiry	
5	VBATREG_EN	1	R/W	A 1 enables VBAT constant voltage regulation capability. Reset condition: RESET_N falling; REG_RST=1; Watchdog Timer Expiry	
4	IBATREG_EN	1	R/W	A 1 enables IBAT constant current regulation capability. Reset condition: RESET_N falling; REG_RST=1; Watchdog Timer Expiry	
3	VOREG_EN	1	R/W	A 1 enables VOUT constant voltage regulation capability. Reset condition: RESET_N falling; REG_RST=1; Watchdog Timer Expiry	
2	TBUSOTP_EN	1	R/W	A 1 enables T_BUS over temperature protection. Reset condition: RESET_N falling; REG_RST=1; Watchdog Timer Expiry	
1	TBATOTP_EN	1	R/W	A 1 enables T_BAT over temperature protection. Reset condition: RESET_N falling; REG_RST=1; Watchdog Timer Expiry	
0	VBUSPD_EN	0	R/W	A 1 enables an internal 100 Ohm pulldown resistor on VBUS. Reset condition: RESET_N falling; REG_RST=1; Watchdog Timer Expiry	

FAN54161

SW_CONTROL				Register Address = 06h	Default = 0010 1000
Bit	Name	Default	Type	Description	
7	VDROPOVP_EN	0	R/W	A 1 enables the VDROP protection circuit. If this protection is enabled, the switch will open whenever $V_{BUS}-V_{OUT} > V_{DROPOVP(TH)}$ for more than $t_{VDROPGLTCH}$. Reset condition: RESET_N falling; REG_RST=1; Watchdog Timer Expiry	
6	VDROPALM_EN	0	R/W	A 1 enables the VDROP alarm circuit. If this alarm is enabled, the IC will flag the host that $V_{BUS}-V_{OUT}$ has exceeded the $V_{DROPALM(TH)}$. Reset condition: RESET_N falling; REG_RST=1; Watchdog Timer Expiry	
5	RSENSE	1	R/W	Program this bit according to the value of the external sense resistor across RSP and RSN.	
				Code	RSENSE Value
				0	5 mΩ
				1	10 mΩ
Reset condition: RESET_N falling; REG_RST=1; Watchdog Timer Expiry					
4	SW_EN	0	R/W	A 1 enables the switch and hardware protection. This bit will automatically reset to 0 when the switch is opened due to a fault condition other than VBUS UVLO. Reset condition: RESET_N falling; REG_RST=1; Watchdog Timer Expiry	
3:2	WDT	10	R/W	This enables and sets the duration of the watch dog timer. When enabled, the watchdog timer is reset by an I ² C read or write command to any register of the FAN54161. A watchdog timer expiry opens the switch and generates an interrupt.	
				Code	WDT Setting
				00	Disabled
				01	0.5 sec
				10	1.0 sec
11	2.0 sec				
Reset condition: RESET_N falling; REG_RST=1; Watchdog Timer Expiry					
1	IRCB	0	R/W	This bit sets the reverse current blocking protection threshold. The direction of reverse current flow through the switch is from VOUT to VBUS.	
				Code	IRCB Threshold (mA)
				0	100
				1	3000
Reset condition: RESET_N falling; REG_RST=1; Watchdog Timer Expiry					
0	REG_RST	0	W1CLR	Setting this bit will reset all I ² C control and interrupt register bits (except status) to their default value. This bit is self-clear.	
				Code	Action
				0	No Effect
				1	Reset I ² C control and interrupt bits to default values
Reset condition: RESET_N falling; REG_RST=1; Watchdog Timer Expiry					

FAN54161

ADC_CONTROL				Register Address = 07h	Default = 1000 0111
Bit	Name	Default	Type	Description	
7	ICTEMPADC_EN	1	R/W	A 1 enables the ADC measurement of the IC temperature. Reset condition: RESET_N falling; REG_RST=1; Watchdog Timer Expiry	
6	Reserved	0	Read	Reserved. Always reads 0.	
5	Reserved	0	Read	Reserved. Always reads 0.	
4	Reserved	0	Read	Reserved. Always reads 0.	
3	ADC_EN	0	R/W	A 1 enables the ADC. Reset condition: RESET_N falling; REG_RST=1; Watchdog Timer Expiry	
2	ADC_RATE	1	R/W	This bit controls the conversion mode of the ADC.	
				Code	ADC Mode
				0	Single Conversion
				1	Continuous Conversion
Reset condition: RESET_N falling; REG_RST=1; Watchdog Timer Expiry					
1	AVG_EN	1	R/W	A 1 enables ADC measurement averaging. Reset condition: RESET_N falling; REG_RST=1; Watchdog Timer Expiry	
0	SAMPLES	1	R/W	This bit sets the number of samples used for an ADC conversion if averaging is enabled.	
				Code	# of ADC Averaging Samples
				0	8
				1	16
Reset condition: RESET_N falling; REG_RST=1; Watchdog Timer Expiry					

ADC_CHANNEL				Register Address = 08h	Default = 1111 1111
Bit	Name	Default	Type	Description	
7	VBUSADC_EN	1	R/W	A 1 enables ADC measurement of V _{BUS} . Reset condition: RESET_N falling; REG_RST=1; Watchdog Timer Expiry	
6	IBUSADC_EN	1	R/W	A 1 enables ADC measurement of I _{BUS} . Reset condition: RESET_N falling; REG_RST=1; Watchdog Timer Expiry	
5	VOUTADC_EN	1	R/W	A 1 enables ADC measurement of V _{OUT} . Reset condition: RESET_N falling; REG_RST=1; Watchdog Timer Expiry	
4	VDROPADC_EN	1	R/W	A 1 enables ADC measurement of V _{DROP} . Reset condition: RESET_N falling; REG_RST=1; Watchdog Timer Expiry	
3	VBATADC_EN	1	R/W	A 1 enables ADC measurement of V _{BAT} via V _{SNSP} and V _{SNSN} . Reset condition: RESET_N falling; REG_RST=1; Watchdog Timer Expiry	
2	IBATADC_EN	1	R/W	A 1 enables ADC measurement of I _{BAT} through the sense resistor across SRP and SRN. Reset condition: RESET_N falling; REG_RST=1; Watchdog Timer Expiry	
1	TBUSADC_EN	1	R/W	A 1 enables ADC measurement of T _{BUS} . Reset condition: RESET_N falling; REG_RST=1; Watchdog Timer Expiry	
0	TBATADC_EN	1	R/W	A 1 enables ADC measurement of T _{BAT} . Reset condition: RESET_N falling; REG_RST=1; Watchdog Timer Expiry	

FAN54161

PROT_DELAY				Register Address = 09h	Default = 1010 0000		
Bit	Name	Default	Type	Description			
7:4	IBUSOCP_TH	1010	R/W	This sets the IBUS over current protection threshold. When IBUS rises above the IBUS over protection threshold, the switch will open and an interrupt will be generated.			
				Code	IBUS OCP Threshold (A)		
				0000	0.5		
				0001	0.5		
				0010	1.0		
				0011	1.5		
				0100	2.0		
				0101	2.5		
				0110	3.0		
				0111	3.5		
				1000	4.0		
				1001	4.5		
				1010	5.0		
				1011	5.5		
				1100	6.0		
				1101	6.5		
1110	7.0						
1111	7.5						
Reset condition: RESET_N falling; REG_RST=1; Watchdog Timer Expiry							
3	Reserved	0	Read	Reserved. Always reads 0.			
2	Reserved	0	Read	Reserved. Always reads 0.			
1	IBUSOCP_MODE	0	R/W	This bit controls the IBUS over current protection mode of operation.			
				Code	IBUS OCP Response After Over Current Fault	IBUS OCP Deglitch Time	
				0	Open switch and reset SW_EN = 0	50 μ s	
				1	Hiccup Mode (open switch and then attempt to close switch every 100 ms up to 7 times before latching switch open if over current fault still exists)	8 μ s	
Reset condition: RESET_N falling; REG_RST=1; Watchdog Timer Expiry							
0	OVP_DLY	0	R/W	This bit sets the deglitch time of the VBUS and VDROP over voltage protection circuits.			
				Code	VBUS OVP Deglitch Time (μs)	VDROP OVP Deglitch Time (μs)	VDROP Alarm Deglitch Time (μs)
				0	4	4	4
				1	20	20	20
Reset condition: RESET_N falling; REG_RST=1; Watchdog Timer Expiry							

FAN54161

VBUSOVP				Register Address = 0Ah	Default = 0011 0100	
Bit	Name	Default	Type	Description		
7	Reserved	0	Read	Reserved. Always reads 0.		
6:0	VBUSOVP_TH	0110100	R/W	This sets the VBUS over voltage protection threshold. When VBUS rises above the VBUS over protection threshold, the switch will open and an interrupt will be generated.		
				Code	VBUSOVP Threshold (V)	
				0000000	4.200	
				0000001	4.225	
				0000010	4.250	
				-	-	
				0110100	5.500	
				-	-	
				1011100 to 1111111	6.500	
Reset condition: RESET_N falling; REG_RST=1; Watchdog Timer Expiry						

VOREG				Register Address = 0Bh	Default = 0001 0100	
Bit	Name	Default	Type	Description		
7	Reserved	0	Read	Reserved. Always reads 0.		
6:0	VOREG	0010100	R/W	This sets the VOREG regulation threshold of the VOUT CV loop. When VOUT rises to the VOREG threshold, the switch will operate in regulation mode and limit VOUT to the VOREG threshold.		
				Code	VOREG (V)	
				0000000	4.20	
				0000001	4.21	
				0000010	4.22	
				-	-	
				0010100	4.40	
				-	-	
				1001111	4.99	
1010000 to 1111111	5.00					
Reset condition: RESET_N falling; REG_RST=1; Watchdog Timer Expiry						

VDROPOVP				Register Address = 0Ch	Default = 0011 1100	
Bit	Name	Default	Type	Description		
7:0	VDROPOVP_TH	00111100	R/W	This sets the VDROPOVP over voltage protection threshold. When VDROPOVP voltage rises above the VDROPOVP over voltage protection threshold, the switch will open and an interrupt will be generated.		
				Code	VDROPOVP Threshold (V)	
				0000 0000	0	
				0000 0001	5	
				0000 0010	10	
				0000 0011	15	
				-	-	
				0011 1100	300	
				-	-	
				11000111	995	
				1100 1000 to 1111 1111	1000	
Reset condition: RESET_N falling; REG_RST=1; Watchdog Timer Expiry						

FAN54161

VDROP_ALM				Register Address = 0Dh	Default = 0001 0100
Bit	Name	Default	Type	Description	
7:0	VDROP_ALM	00010100	R/W	This sets the VDROP alarm threshold. When VDROP voltage rises above the VDROP alarm threshold, an interrupt will be generated.	
				Code	VDROP Alarm Threshold (V)
				0000 0000	0
				0000 0001	5
				0000 0010	10
				-	-
				0001 0100	100
				-	-
				1100 0111	995
				1100 0000 to 1111 1111	1000
Reset condition: RESET_N falling; REG_RST=1; Watchdog Timer Expiry					

VBATREG				Register Address = 0Eh	Default = 0000 1011
Bit	Name	Default	Type	Description	
7	Reserved	0	Read	Reserved. Always reads 0.	
6:0	VBATREG	0001010	R/W	This sets the VBATREG regulation threshold of the VBAT CV loop. When $V_{SNSP} - V_{SNSN}$ rises to the VBATREG threshold, the switch will operate in regulation mode and limit $V_{SNSP} - V_{SNSN}$ to the VBATREG threshold.	
				Code	VBATREG Threshold (V)
				0000000	4.20
				0000001	4.21
				0000010	4.22
				-	-
				0001010	4.3
				-	-
				1001111	4.99
				1010000 to 1111111	5.00
Reset condition: RESET_N falling; REG_RST=1; Watchdog Timer Expiry					

IBATREG				Register Address = 0Fh	Default = 0010 1000
Bit	Name	Default	Type	Description	
7	Reserved	0	Read	Reserved. Always reads 0.	
6:0	IBATREG	0101000	R/W	This sets the IBATREG regulation threshold of the IBAT CC loop. When the measured IBAT current rises above the IBATREG threshold, the switch will operate in regulation mode to limit the IBAT current to IBATREG. The IBAT current is sensed using the SRP and SRN pins with an external R_{SENSE} resistor.	
				Code	IBATREG Threshold (V)
				0000000	0.10
				0000001	0.10
				0000010	0.10
				0000011	0.15
				-	-
				0101000	2.00
				-	-
				1111101	6.25
				1111110	6.30
				1111111	6.35
Reset condition: RESET_N falling; REG_RST=1; Watchdog Timer Expiry					

FAN54161

IBUSREG				Register Address = 10h	Default = 0100 0110
Bit	Name	Default	Type	Description	
7:0	IBUSREG	01000110	R/W	This sets the IBUSREG regulation threshold of the IBUS CC loop. When the measured IBUS current rises above the IBUSREG threshold, the switch will operate in regulation mode to limit the IBUS current to IBUSREG. The IBUS current is sensed internally through the switch.	
				Code	IBUSREG Threshold (A)
				0000 0000	0.10
				0000 0001	0.10
				0000 0010	0.10
				0000 0011	0.15
				-	-
				0100 0110	3.50
				-	-
				1000 0000	6.40
				1000 0001	6.45
				1000 0010 to 1111 1111	6.50
Reset condition: RESET_N falling; REG_RST=1; Watchdog Timer Expiry					

TBUSOTP				Register Address = 11h	Default = 0001 1110
Bit	Name	Default	Type	Description	
7	Reserved	0	Read	Reserved. Always reads 0.	
6:0	TBUS_TH	0011110	R/W	This sets the T_BUS over temperature threshold. When the ADC measurement of the T_BUS voltage falls below the T_BUS over temperature voltage threshold, the switch will open and a VBUS connector over-temperature interrupt will be generated. An external NTC thermistor is used to measure the temperature of the VBUS connector.	
				Code	T_BUS Over Temperature Threshold (V)
				0000 0000	0.0
				0000 0001	0.02
				0000 0010	0.04
				-	-
				0011110	0.60
				-	-
				1110111	2.38
				1111000 to 1111 1111	2.40
Reset condition: RESET_N falling; REG_RST=1; Watchdog Timer Expiry					

TBATOTP				Register Address = 12h	Default = 0010 0011
Bit	Name	Default	Type	Description	
7	Reserved	0	Read	Reserved. Always reads 0.	
6:0	TBAT_TH	0100011	R/W	This sets the T_BAT over temperature threshold. When the ADC measurement of the T_BAT voltage falls below the T_BAT over temperature voltage threshold, the switch will open and a battery over-temperature interrupt will be generated. An external NTC thermistor can be used to measure the temperature of the battery.	
				Code	T_BAT Over Temperature Threshold (V)
				0000 0000	0.0
				0000 0001	0.02
				0000 0010	0.04
				-	-
				0100011	0.70
				-	-
				1110111	2.38
				1111000 to 1111 1111	2.40
Reset condition: RESET_N falling; REG_RST=1; Watchdog Timer Expiry					

FAN54161

VBUS_MSB				Register Address = 13h	Default = 0000 0000
Bit	Name	Default	Type	Description	
7	Reserved	0	Read	Reserved. Always reads 0.	
6	Reserved	0	Read	Reserved. Always reads 0.	
5	Reserved	0	Read	Reserved. Always reads 0.	
4:0	VBUSADC_MSB	00000	Read	VBUSADC_MSB along with VBUSADC_LSB form the 13 bit result of the VBUS voltage. When $V_{BUS} < 300\text{mV}$, VBUSADC will report 0V.	
				VBUSADC (b)	VBUSADC (h)
				0000000000000	0000
				0000100101100	012C
				0000100101101	012D
				-	-
				1011111010011	17D3
				1011111010100	17D4
				VBUS (mV)	
				0 to 299	
				300	
				301	
				-	
				6099	
				6100	
				Reset condition: RESET_N falling; REG_RST=1; Watchdog Timer Expiry	

VBUS_LSB				Register Address = 14h	Default = 0000 0000
Bit	Name	Default	Type	Description	
7:0	VBUSADC_LSB	00000000	Read	VBUSADC_LSB along with VBUSADC_MSB (REG 13h[4:0]) form the 13 bit result of the VBUS voltage. When $V_{BUS} < 300\text{mV}$, VBUSADC will report 0V.	
				Reset condition: RESET_N falling; REG_RST=1; Watchdog Timer Expiry	

IBUS_MSB				Register Address = 15h	Default = 0000 0000
Bit	Name	Default	Type	Description	
7	Reserved	0	Read	Reserved. Always reads 0.	
6	Reserved	0	Read	Reserved. Always reads 0.	
5	Reserved	0	Read	Reserved. Always reads 0.	
4:0	IBUSADC_MSB	00000	Read	IBUSADC_MSB along with IBUSADC_LSB form the 13 bit result of the IBUS current.	
				IBUSADC (b)	IBUSADC (h)
				0000000000000	0000
				0000000000001	0001
				0000000000010	0002
				-	-
				1101101010111	1B57
				1101101011000	1B58
				IBUS (mA)	
				0	
				1	
				2	
				-	
				6999	
				7000	
				Reset condition: RESET_N falling; REG_RST=1; Watchdog Timer Expiry	

IBUS_LSB				Register Address = 16h	Default = 0000 0000
Bit	Name	Default	Type	Description	
7:0	IBUSADC_LSB	00000000	Read	IBUSADC_MSB along with IBUSADC_LSB (REG15h[4:0]) form the 13 bit result of the IBUS current.	
				Reset condition: RESET_N falling; REG_RST=1; Watchdog Timer Expiry	

FAN54161

VOUT_MSB				Register Address = 17h	Default = 0000 0000
Bit	Name	Default	Type	Description	
7	Reserved	0	Read	Reserved. Always reads 0.	
6	Reserved	0	Read	Reserved. Always reads 0.	
5	Reserved	0	Read	Reserved. Always reads 0.	
4:0	VOUTADC_MSB	00000	Read	VOUTADC_MSB along with VOUTADC_LSB form the 13 bit result of the VOUT voltage.	
				VOUTADC (b)	VOUTADC (h)
				000000000000	0000
				0000000000001	0001
				0000000000010	0002
				-	-
				1001110000111	1387
				1001110001000	1388
				VOUT (mV)	VOUT (mV)
				0	0
				1	1
				2	2
				-	-
				4999	4999
				5000	5000
Reset condition: RESET_N falling; REG_RST=1; Watchdog Timer Expiry					

VOUT_LSB				Register Address = 18h	Default = 0000 0000
Bit	Name	Default	Type	Description	
7:0	VOUTADC_LSB	00000000	Read	VOUTADC_LSB along with VOUTADC_MSB (REG17h[4:0]) form the 13 bit result of the VOUT voltage.	
Reset condition: RESET_N falling; REG_RST=1; Watchdog Timer Expiry					

VDROP_MSB				Register Address = 19h	Default = 0000 0000
Bit	Name	Default	Type	Description	
7	Reserved	0	Read	Reserved. Always reads 0.	
6	Reserved	0	Read	Reserved. Always reads 0.	
5	Reserved	0	Read	Reserved. Always reads 0.	
4	Reserved	0	Read	Reserved. Always reads 0.	
3	Reserved	0	Read	Reserved. Always reads 0.	
2	Reserved	0	Read	Reserved. Always reads 0.	
1:0	VDROPADC_MSB	00	Read	VDROPADC_LSB along with VDROPADC_MSB form the 10 bit result of the VDROP voltage = $V_{BUS} - V_{OUT}$.	
				VDROPADC (b)	VDROPADC (h)
				000000000	0000
				0000000001	0001
				0000000010	0002
				-	-
				1111100111	3E7
				1111101000	3E8
				VDROP (mV)	VDROP (mV)
				0	0
				1	1
				2	2
				-	-
				999	999
				1000	1000
Reset condition: RESET_N falling; REG_RST=1; Watchdog Timer Expiry					

VDROP_LSB				Register Address = 1Ah	Default = 0000 0000
Bit	Name	Default	Type	Description	
7:0	VDROPADC_LSB	00000000	Read	VDROPADC_LSB along with VDROPADC_MSB (REG19h[1:0]) form the 10 bit result of the VDROP voltage = $V_{BUS} - V_{OUT}$.	
Reset condition: RESET_N falling; REG_RST=1; Watchdog Timer Expiry					

FAN54161

VBAT_MSB				Register Address = 1Bh	Default = 0000 0000
Bit	Name	Default	Type	Description	
7	Reserved	0	Read	Reserved. Always reads 0.	
6	Reserved	0	Read	Reserved. Always reads 0.	
5	Reserved	0	Read	Reserved. Always reads 0.	
4:0	VBATADC_MSB	00000	Read	VBATADC_LSB along with VBATADC_MSB form the 13 bit result of the $V_{BAT} = V_{SNSP} - V_{SNSN}$.	
				VBATADC (b)	VBATADC (h)
				0000000000000	0000
				0000000000001	0001
				0000000000010	0002
				-	-
				1001110000111	1387
				1001110001000	1388
					VBAT (mV)
					0
					1
					2
					-
					4999
					5000
				Reset condition: RESET_N falling; REG_RST=1; Watchdog Timer Expiry	

VBAT_LSB				Register Address = 1Ch	Default = 0000 0000
Bit	Name	Default	Type	Description	
7:0	VBATADC_LSB	00000000	Read	VBATADC_LSB along with VBATADC_MSB (REG1B[4:0]) form the 13 bit result of the $V_{BAT} = V_{SNSP} - V_{SNSN}$.	
				Reset condition: RESET_N falling; REG_RST=1; Watchdog Timer Expiry	

IBAT_MSB				Register Address = 1Dh	Default = 0000 0000
Bit	Name	Default	Type	Description	
7	IBATADC_POL	0	Read	Polarity of IBAT_ADC result. 0 – positive (+) 1 – negative (-)	
6	Reserved	0	Read	Reserved. Always reads 0.	
5	Reserved	0	Read	Reserved. Always reads 0.	
4:0	IBATADC_MSB	00000	Read	IBATADC_MSB along with IBATADC_LSB form the 13 bit ADC measurement of the IBAT current measured through R _{SENSE} across SRP and SRN pins.	
				IBUSADC (b)	IBUSADC (h)
				0000000000000	0000
				0000000000001	0001
				0000000000010	0002
				-	-
				1101101010111	1387
				1101101011000	1388
					IBUS (mA)
					0
					1
					2
					-
					6999
					7000
				Reset condition: RESET_N falling; REG_RST=1; Watchdog Timer Expiry	

IBAT_LSB				Register Address = 1Eh	Default = 0000 0000
Bit	Name	Default	Type	Description	
7:0	IBATADC_LSB	00000000	Read	IBATADC_LSB along with IBATADC_MSB (REG1Dh[4:0]) form the 13 bit ADC measurement of the IBAT current measured through R _{SENSE} across SRP and SRN pins.	
				Reset condition: RESET_N falling; REG_RST=1; Watchdog Timer Expiry	

FAN54161

TBUS_MSB				Register Address = 1Fh	Default = 0000 0000
Bit	Name	Default	Type	Description	
7	Reserved	0	Read	Reserved. Always reads 0.	
6	Reserved	0	Read	Reserved. Always reads 0.	
5	Reserved	0	Read	Reserved. Always reads 0.	
4	Reserved	0	Read	Reserved. Always reads 0.	
3:0	TBUSADC_MSB	0000	Read	TBUSADC_MSB along with TBUSADC_LSB form the raw bit ADC measurement of the TS_BUS voltage formed by the external NTC thermistor network used to sense the temperature of the input connector. A 2.4V external reference is recommended.	
				TBUSADC (b)	TBUSADC (h)
				000000000000	0000
				0000000000001	0001
				0000000000010	0002
				-	-
				100101011111	95F
				100101100000	960
					TBAT (mV)
					0
					1
					2
					-
					2399
					2400
Reset condition: RESET_N falling; REG_RST=1; Watchdog Timer Expiry					

TBUS_LSB				Register Address = 20h	Default = 0000 0000
Bit	Name	Default	Type	Description	
7:0	TBUSADC_LSB	00000000	Read	TBUSADC_LSB along with TBUSADC_MSB (REG1Fh[3:0]) form the 12 bit result of the TS_BUS voltage formed by the external NTC thermistor network used to sense the temperature of the input connector. A 2.4V external reference is recommended. Reset condition: RESET_N falling; REG_RST=1; Watchdog Timer Expiry	

TBAT_MSB				Register Address = 21h	Default = 0000 0000
Bit	Name	Default	Type	Description	
7	Reserved	0	Read	Reserved. Always reads 0.	
6	Reserved	0	Read	Reserved. Always reads 0.	
5	Reserved	0	Read	Reserved. Always reads 0.	
4	Reserved	0	Read	Reserved. Always reads 0.	
3:0	TBATADC_MSB	0000	Read	TBATADC_MSB along with TBATADC_LSB form the 12 bit result of the TS_BAT voltage formed by the external NTC thermistor network used to sense the temperature of the battery. A 2.4V external reference is recommended.	
				TBATADC (b)	TBATADC (h)
				000000000000	0000
				0000000000001	0001
				0000000000010	0002
				-	-
				100101011111	95F
				100101100000	960
					TBAT (mV)
					0
					1
					2
					-
					2399
					2400
Reset condition: RESET_N falling; REG_RST=1; Watchdog Timer Expiry					

TBAT_LSB				Register Address = 22h	Default = 0000 0000
Bit	Name	Default	Type	Description	
7:0	TBATADC_LSB	00000000	Read	TBATADC_LSB along with TBATADC_MSB (reg21h[3:0]) form the 12 bit result of the TS_BAT voltage formed by the external NTC thermistor network used to sense the temperature of the battery. A 2.4V external reference is recommended. Reset condition: RESET_N falling; REG_RST=1; Watchdog Timer Expiry	

FAN54161

ICTEMP_LSB				Register Address = 23h	Default = 0000 0000	
Bit	Name	Default	Type	Description		
7:0	ICTEMPADC	00000000	Read	ICTEMPADC forms the 8 bit result of the IC's internal die temperature sensor.		
				ICTEMPADC (b)	ICTEMPADC (h)	ICTEMP (°C)
				00000000	0	0
				-	-	-
				00011001	19	25
				00011010	1A	26
				00011011	1B	27
				-	-	-
				10010101	95	149
				10010110	96	150
Reset condition: RESET_N falling; REG_RST=1; Watchdog Timer Expiry						

CONTROL1				Register Address = 50h	Default = 0100 0011
Bit	Name	Default	Type	Description	
7:6	TJSHDN	01	R/W	TJSHDN programs the thermal shutdown threshold.	
				Code	Junction Temperature Threshold (°C)
				00	115
				01	125
				10	135
				11	145
Reset condition: RESET_N falling; REG_RST=1; Watchdog Timer Expiry					
5	Reserved	0	Read	Reserved	
4	VOUTOVP_DLY	0	R/W	This bit sets the deglitch time of the VOUT over voltage protection circuit.	
				Code	VOUT OVP Deglitch Time (µS)
				00	4
				01	20
Reset condition: RESET_N falling; REG_RST=1; Watchdog Timer Expiry					
3	VOUTOVP_EN	0	R/W	A 1 enables the VOUT OVP protection circuit. If enabled and VOUT > VOUTOVP, the switch is forced open. Reset condition: RESET_N falling; REG_RST=1; Watchdog Timer Expiry	
2	VFAIL_EN	0	R/W	A 1 enables a detection mechanism that senses if the bypass switch is permanently shorted. RESET_N falling; REG_RST=1; Watchdog Timer Expiry	
1	IBUSRCB_EN	1	R/W	A 1 (default setting) enables IBUS reverse current blocking protection. Reset condition: RESET_N falling; REG_RST=1; Watchdog Timer Expiry	
0	IBUSOCP_EN	1	R/W	A 1 (default setting) enables the IBUS over current protection circuit that is set by a programmable IBUSOCP threshold. Reset condition: RESET_N falling; REG_RST=1; Watchdog Timer Expiry	

FAN54161

CONTROL2				Register Address = 51h	Default = 0001 0100	
Bit	Name	Default	Type	Description		
7	Reserved	0	Read	Reserved. Always reads 0.		
6:0	VOUTOVP_TH	0010100	R/W	This sets the VOUT OVP threshold. When VOUT rises above its OVP threshold, the switch will open.		
				Code	VOUT OVP Threshold (V)	
				0000000	4.50	
				0000001	4.51	
				0000010	4.52	
				-	-	
				0010100	4.70	
				-	-	
				1001111	5.29	
				1010000 to 1111111	5.30	
Reset condition: RESET_N falling; REG_RST=1; Watchdog Timer Expiry						

INT3 MASK				Register Address = 52h	Default = 0000 0001
Bit	Name	Default	Type	Description	
7	Reserved	0	Read	Reserved. Always reads 0.	
6	Reserved	0	Read	Reserved. Always reads 0.	
5	Reserved	0	Read	Reserved. Always reads 0.	
4	Reserved	0	Read	Reserved. Always reads 0.	
3	VOUTOVP_M	0	R/W	A 1 sets the interrupt mask for a VOUT OVP fault. Reset condition: RESET_N falling; REG_RST=1; Watchdog Timer Expiry	
2	VFAIL_M	0	R/W	A 1 sets the interrupt mask for a VFAIL fault. Reset condition: RESET_N falling; REG_RST=1; Watchdog Timer Expiry	
1	VUSBOVP_M	0	R/W	A 1 sets the interrupt mask for a VUSBOVP fault. Reset condition: RESET_N falling; REG_RST=1; Watchdog Timer Expiry	
0	VUSBINSERT_M	1	R/W	A 1 (default setting) sets the interrupt mask for a USB insertion or removal event. Reset condition: RESET_N falling; REG_RST=1; Watchdog Timer Expiry	

FAN54161

INT3				Register Address = 53h	Default = 0000 0000
Bit	Name	Default	Type	Description	
7	Reserved	0	Read	Reserved. Always reads 0.	
6	Reserved	0	Read	Reserved. Always reads 0.	
5	Reserved	0	Read	Reserved. Always reads 0.	
4	TIMER_INT	0	R/CLR	This interrupt is set when the watchdog timer has expired. Reset condition: RESET_N falling; REG_RST=1	
3	VOUTOVP_INT	0	R/CLR	This interrupt is set when VOUT exceeds $V_{OUTOVP(TH)}$. Reset condition: RESET_N falling; REG_RST=1; Watchdog Timer Expiry	
2	VFAIL_INT	0	R/CLR	This interrupt is set when the common source voltage of the bypass switch is above the V_{FAIL} threshold when the switch is open (SW_EN=0). A "1" would indicate that the bypass switch has failed and the host processor should flag the user to service the device. Reset condition: RESET_N falling; REG_RST=1; Watchdog Timer Expiry	
1	VUSBOVP_INT	0	R/CLR	This interrupt is set when V_{USB} exceeds the V_{USBOVP} threshold. Reset condition: RESET_N falling; REG_RST=1; Watchdog Timer Expiry	
0	VUSBINSERT_INT	0	R/CLR	This interrupt is set when V_{USB} rises above $V_{USBVLO(TH)}$ or falls below $V_{USBVLO(TH)} - V_{USBVLO(HYS)}$. When an external OVP blocking FET is not used, the floating VUSB pin can still exceed the $V_{USBVLO(TH)}$ threshold during a VBUS OVP event causing a false VUSBINSERT interrupt. It is recommended to mask this bit when no external FET is used to prevent the INT pin from pulling low due to a VBUS OVP event. Masking this bit does not prevent it from being set, so this bit should be ignored when an external OVP blocking FET is not used. Reset condition: RESET_N falling; REG_RST=1; Watchdog Timer Expiry	

STATUS1				Register Address = 54h	Default = 0000 0100
Bit	Name	Default	Type	Description	
7	VOREG_ST	0	Read	A 1 indicates that the VOREG CV regulation loop is active. Reset condition: RESET_N falling; REG_RST=1; Watchdog Timer Expiry	
6	VBATREG_ST	0	Read	A 1 indicates that the VBATREG CV regulation loop is active Reset condition: RESET_N falling; REG_RST=1; Watchdog Timer Expiry	
5	IBATREG_ST	0	Read	A 1 indicates that the IBATREG CC regulation loop is active. Reset condition: RESET_N falling; REG_RST=1; Watchdog Timer Expiry	
4	IBUSREG_ST	0	Read	A 1 indicates that the IBUSREG CC regulation loop is active. Reset condition: RESET_N falling; REG_RST=1; Watchdog Timer Expiry	
3	VBUSINSERT_ST	0	Read	A 1 indicates that V_{BUS} is above $V_{BUSVLO(TH)}$. When the switch is open (SW_EN=0) and the ADC is disabled (ADC_EN=0), this bit is latched to 0 regardless if there is a valid source on VBUS. Reset condition: RESET_N falling; REG_RST=1; Watchdog Timer Expiry	
2	VBATINSERT_ST	1	Read	A 1 indicates that V_{SNSP} is above $V_{BATINSERT(TH)}$. Reset condition: RESET_N falling; REG_RST=1; Watchdog Timer Expiry	
1	Reserved	0	Read	Reserved. Always reads 0.	
0	VUSBINSERT_ST	0	Read	A 1 indicates that V_{USB} is above $V_{USBVLO(TH)}$. Reset condition: RESET_N falling; REG_RST=1; Watchdog Timer Expiry	

FAN54161

PRODUCT SPECIFIC DIMENSIONS

Product	D (mm)	E (mm)	X (mm)	Y (mm)
FAN54161UCX	2.78 +/-0.03	3.06 +/-0.03	0.370	0.310

PACKAGE DIMENSIONS

WLCSP42 2.78x3.06x0.65
CASE 567TY
ISSUE O

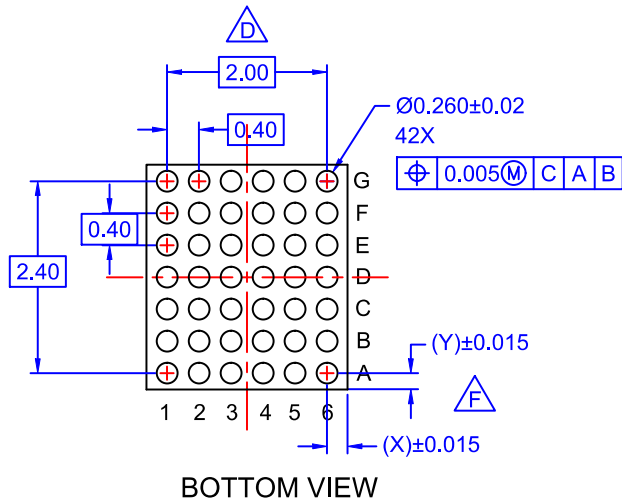
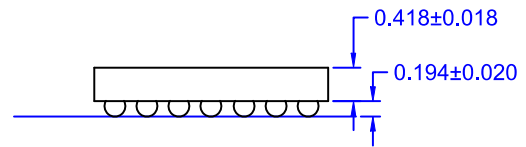
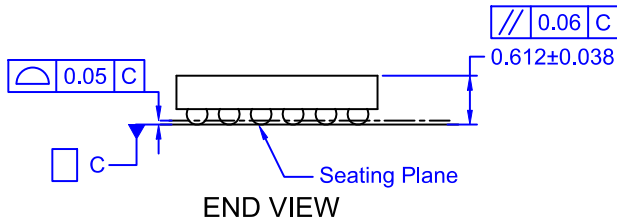
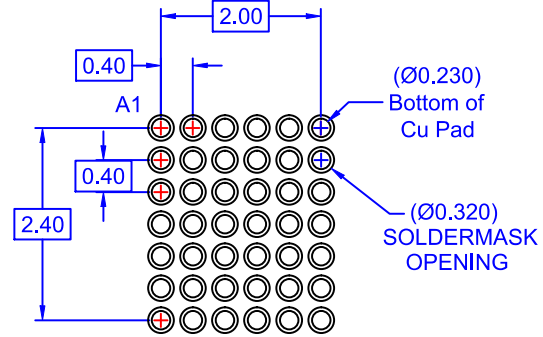
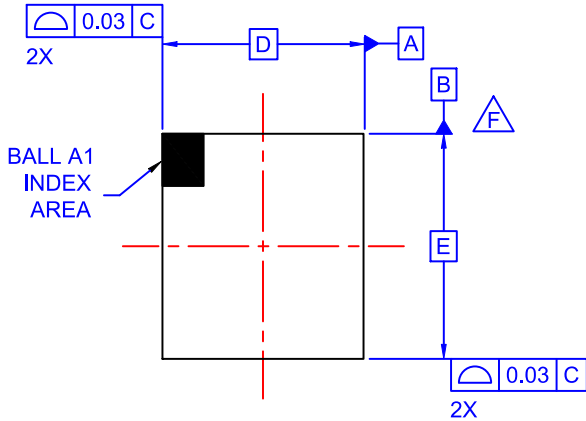

NOTES

- A. NO JEDEC REGISTRATION APPLIES.
- B. DIMENSIONS ARE IN MILLIMETERS.
- C. DIMENSIONS AND TOLERANCE PER ASMEY14.5M, 2009.
- D. DATUM C IS DEFINED BY THE SPHERICAL CROWNS OF THE BALLS.
- E. PACKAGE NOMINAL HEIGHT IS 612 ± 38 MICRONS (574-650 MICRONS).
- F. FOR DIMENSIONS D, E, X, AND Y SEE PRODUCT DATASHEET.

ON Semiconductor and  are trademarks of Semiconductor Components Industries, LLC dba ON Semiconductor or its subsidiaries in the United States and/or other countries. ON Semiconductor owns the rights to a number of patents, trademarks, copyrights, trade secrets, and other intellectual property. A listing of ON Semiconductor's product/patent coverage may be accessed at www.onsemi.com/site/pdf/Patent-Marking.pdf. ON Semiconductor reserves the right to make changes without further notice to any products herein. ON Semiconductor makes no warranty, representation or guarantee regarding the suitability of its products for any particular purpose, nor does ON Semiconductor assume any liability arising out of the application or use of any product or circuit, and specifically disclaims any and all liability, including without limitation special, consequential or incidental damages. Buyer is responsible for its products and applications using ON Semiconductor products, including compliance with all laws, regulations and safety requirements or standards, regardless of any support or applications information provided by ON Semiconductor. "Typical" parameters which may be provided in ON Semiconductor data sheets and/or specifications can and do vary in different applications and actual performance may vary over time. All operating parameters, including "Typicals" must be validated for each customer application by customer's technical experts. ON Semiconductor does not convey any license under its patent rights nor the rights of others. ON Semiconductor products are not designed, intended, or authorized for use as a critical component in life support systems or any FDA Class 3 medical devices or medical devices with a same or similar classification in a foreign jurisdiction or any devices intended for implantation in the human body. Should Buyer purchase or use ON Semiconductor products for any such unintended or unauthorized application, Buyer shall indemnify and hold ON Semiconductor and its officers, employees, subsidiaries, affiliates, and distributors harmless against all claims, costs, damages, and expenses, and reasonable attorney fees arising out of, directly or indirectly, any claim of personal injury or death associated with such unintended or unauthorized use, even if such claim alleges that ON Semiconductor was negligent regarding the design or manufacture of the part. ON Semiconductor is an Equal Opportunity/Affirmative Action Employer. This literature is subject to all applicable copyright laws and is not for resale in any manner.

PUBLICATION ORDERING INFORMATION

LITERATURE FULFILLMENT:

Literature Distribution Center for ON Semiconductor
19521 E. 32nd Pkwy, Aurora, Colorado 80011 USA
Phone: 303-675-2175 or 800-344-3860 Toll Free USA/Canada
Fax: 303-675-2176 or 800-344-3867 Toll Free USA/Canada
Email: orderlit@onsemi.com

N. American Technical Support: 800-282-9855 Toll Free
USA/Canada
Europe, Middle East and Africa Technical Support:
Phone: 421 33 790 2910

ON Semiconductor Website: www.onsemi.com

Order Literature: <http://www.onsemi.com/orderlit>

For additional information, please contact your local
Sales Representative



Компания «ЭлектроПласт» предлагает заключение долгосрочных отношений при поставках импортных электронных компонентов на взаимовыгодных условиях!

Наши преимущества:

- Оперативные поставки широкого спектра электронных компонентов отечественного и импортного производства напрямую от производителей и с крупнейших мировых складов;
- Поставка более 17-ти миллионов наименований электронных компонентов;
- Поставка сложных, дефицитных, либо снятых с производства позиций;
- Оперативные сроки поставки под заказ (от 5 рабочих дней);
- Экспресс доставка в любую точку России;
- Техническая поддержка проекта, помощь в подборе аналогов, поставка прототипов;
- Система менеджмента качества сертифицирована по Международному стандарту ISO 9001;
- Лицензия ФСБ на осуществление работ с использованием сведений, составляющих государственную тайну;
- Поставка специализированных компонентов (Xilinx, Altera, Analog Devices, Intersil, Interpoint, Microsemi, Aeroflex, Peregrine, Syfer, Eurofarad, Texas Instrument, Miteq, Cobham, E2V, MA-COM, Hittite, Mini-Circuits, General Dynamics и др.);

Помимо этого, одним из направлений компании «ЭлектроПласт» является направление «Источники питания». Мы предлагаем Вам помощь Конструкторского отдела:

- Подбор оптимального решения, техническое обоснование при выборе компонента;
- Подбор аналогов;
- Консультации по применению компонента;
- Поставка образцов и прототипов;
- Техническая поддержка проекта;
- Защита от снятия компонента с производства.



Как с нами связаться

Телефон: 8 (812) 309 58 32 (многоканальный)

Факс: 8 (812) 320-02-42

Электронная почта: org@eplast1.ru

Адрес: 198099, г. Санкт-Петербург, ул. Калинина, дом 2, корпус 4, литера А.