

High Isolation X-SPDT (DP4T) SWITCH

■ GENERAL DESCRIPTION

The NJG1800NB2 is a GaAs X (cross) – SPDT (DP4T) switch MMIC, which is designed for switching of balanced (differential) dual band filters. The switch IC features very low insertion loss and very high isolation for balanced signal input. It has integrated DC blocking capacitors at PC1 and PC2 ports. The ESD protection circuits are integrated in the IC to achieve high ESD tolerance.

The NJG1800NB2 is assembled in a very small, lead-free, halogen-free, 1.55mm x 1.15mm, 10-pin EPCSP10-B2 package.

*) X-SPDT is a paired SPDT switch controlled synchronously. The X-SPDT includes two SPDT switches whose RF lines have a crossing inside the chip.

■ PACKAGE OUTLINE

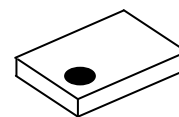

NJG1800NB2

■ APPLICATIONS

Balanced filter switching application

LTE, UMTS, CDMA and GSM Multi-mode or Multi-band applications

Mobile phone, Tablet PC, Data card, Router and others mobile device applications

■ FEATURES

- Low operation voltage $V_{DD}=2.7V$ typ.
- Low control voltage $V_{CTL(H)}=1.8V$ typ.
- High isolation
(Balanced mode) 39dB typ. @f=2.0GHz, $P_{IN}=0dBm$
37dB typ. @f=2.7GHz, $P_{IN}=0dBm$
- Low insertion loss
(Balanced mode) 0.38dB typ. @f=2.0GHz, $P_{IN}=0dBm$
0.36dB typ. @f=2.7GHz, $P_{IN}=0dBm$
- Small and thin package EPCSP10-B2 (Package size: 1.55x1.15x0.55mm)
- RoHS compliant and Halogen Free
- MSL1

■ PIN CONFIGURATION

(Top View)

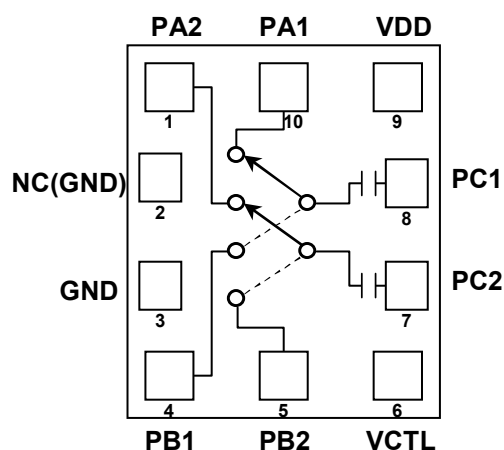

Pin connection

1. PA2
2. NC (GND)
3. GND
4. PB1
5. PB2
6. VCTL
7. PC2
8. PC1
9. VDD
10. PA1

■ TRUTH TABLE

“H”= $V_{CTL(H)}$, “L”= $V_{CTL(L)}$

ON PATH	VCTL
PC1-PA1, PC2-PA2	H
PC1-PB1, PC2-PB2	L

NOTE: The Information on this datasheet will be subject to change without notice.

NJG1800NB2

■ ABSOLUTE MAXIMUM RATINGS

$T_a=+25^{\circ}\text{C}$, Balanced mode $Z_s=Z_l=100\Omega$, Singled mode $Z_s=Z_l=50\Omega$

PARAMETER	SYMBOL	CONDITIONS	RATINGS	UNITS
RF input power	P_{IN}	$V_{DD}=2.7\text{V}$, $V_{CTL}=0\text{V}/1.8\text{V}$	28	dBm
Supply voltage	V_{DD}	VDD terminal	5.0	V
Control voltage	V_{CTL}	VCTL terminal	5.0	V
Power dissipation	P_D	Four-layer FR4 PCB (101.5mmx114.5mm without through-hole), $T_j=150^{\circ}\text{C}$	320	mW
Operating temp.	T_{opr}		-40~+90	$^{\circ}\text{C}$
Storage temp.	T_{stg}		-55~+150	$^{\circ}\text{C}$

■ ELECTRICAL CHARACTERISTICS

Balanced mode $Z_s=Z_l=100\Omega$, Singled mode $Z_s=Z_l=50\Omega$, $T_a=+25^\circ\text{C}$, $V_{DD}=2.7\text{V}$, $V_{CTL(L)}=0\text{V}$, $V_{CTL(H)}=1.8\text{V}$

PARAMETERS	SYMBOL	CONDITIONS	MIN	TYP	MAX	UNITS
Supply voltage	V_{DD}		1.5	2.7	4.5	V
Operating current	I_{DD}	No RF input, $V_{DD}=2.7\text{V}$	-	13	30	μA
Control voltage (LOW)	$V_{CTL(L)}$		0	-	0.45	V
Control voltage (HIGH)	$V_{CTL(H)}$		1.35	1.8	4.5	V
Control current	I_{CTL}	$V_{CTL(H)}=1.8\text{V}$	-	3	10	μA
Balanced mode Insertion loss 1 <small>(Note1)</small>	B-LOSS1	f=0.5GHz, PC-PA,PB	-	0.45	0.65	dB
Balanced mode Insertion loss 2	B-LOSS2	f=1.0GHz, PC-PA,PB	-	0.40	0.60	dB
Balanced mode Insertion loss 3	B-LOSS3	f=2.0GHz, PC-PA,PB	-	0.38	0.58	dB
Balanced mode Insertion loss 4	B-LOSS4	f=2.7GHz, PC-PA,PB	-	0.36	0.56	dB
Balanced mode Isolation 1 <small>(Note1)</small>	B-ISL1	f=0.5 GHz, PC-PA,PB	45	50		dB
Balanced mode Isolation 2	B-ISL2	f=1.0GHz, PC-PA,PB	40	45		dB
Balanced mode Isolation 3	B-ISL3	f=2.0GHz, PC-PA,PB	34	39		dB
Balanced mode Isolation 4	B-ISL4	f=2.7GHz, PC-PA,PB	32	37	-	dB
Input power at 0.2dB compression point	$P_{-0.2\text{dB}}$	f=2.0GHz, PC1-PA1,PB1, PC2-PA2,PB2	18	22	-	dBm
VSWR	VSWR	f=2.0GHz, PC1-PA1,PB1, PC2-PA2,PB2	-	1.2	1.4	
Switching time	T_{sw}	50% CTL to 10%/90% RF	-	1.5	5.0	μs

Note1:

The conversion of singled mode S-parameter to balanced mode S-parameter uses the following formula.

$$B - \text{LOSS}, B - \text{ISL} = \frac{1}{2}(S_{21} - S_{23} - S_{41} + S_{43})$$

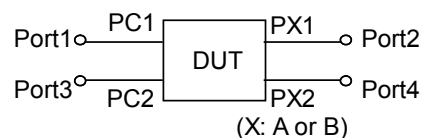

NJG1800NB2

■ TERMINAL INFORMATION

No.	SYMBOL	DESCRIPTION
1	PA2	This port is connected to PC2 terminal by applying High-level (1.35~4.5V) at VCTL terminal. An external capacitor is required to block DC voltage of internal circuit.
2	NC(GND)	No connected terminal. This terminal is not connected with internal circuit. Please connect to the PCB ground Plane.
3	GND	Ground terminal. Please connect this terminal with ground plane as close as possible for good RF performance.
4	PB1	This port is connected to PC1 terminal by applying Low-level (0~0.45V) at VCTL terminal. An external capacitor is required to block DC voltage of internal circuit.
5	PB2	This port is connected to PC2 terminal by applying Low-level (0~0.45V) at VCTL terminal. An external capacitor is required to block DC voltage of internal circuit.
6	VCTL	Control signal input terminal. This terminal is set to high-level (1.35V~4.5V) or low-level (0~0.45V).
7	PC2	Common RF port. This port is connected with either of PA2 or PB2. No external capacitors are required.
8	PC1	Common RF port. This port is connected with either of PA1 or PB1. No external capacitors are required.
9	VDD	A supply voltage terminal (1.5~4.5V). Please place a bypass capacitor between this terminal and GND for avoiding RF noise from outside.
10	PA1	This port is connected to PC1 terminal by applying High-level (1.35~4.5V) at VCTL terminal. An external capacitor is required to block DC voltage of internal circuit.

■ ELECTRICAL CHARACTERISTICS (With application circuit, Loss of external circuit are excluded)

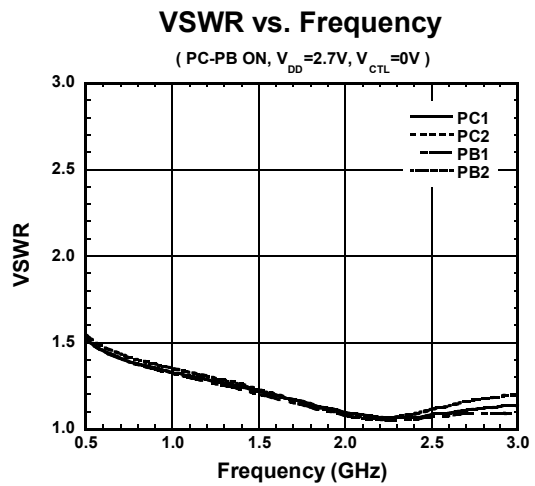
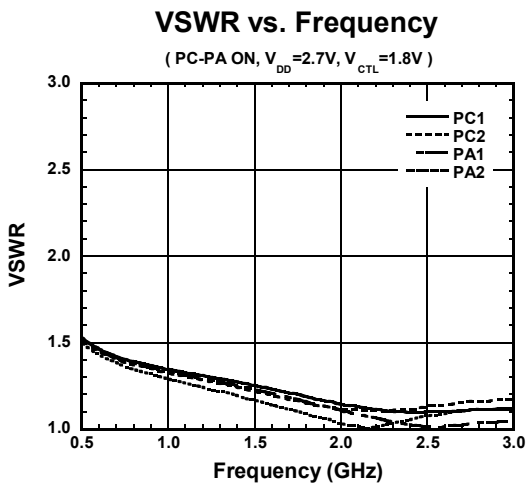
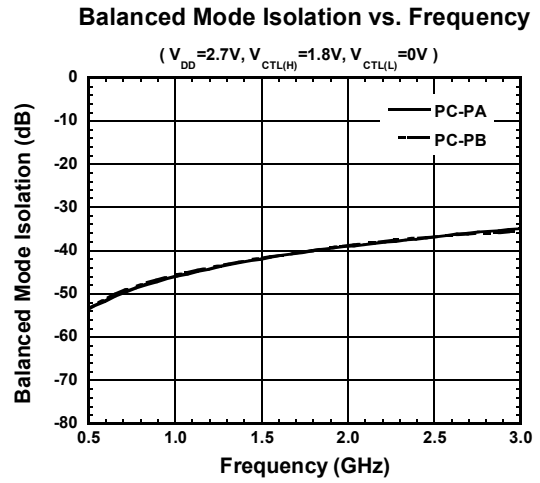
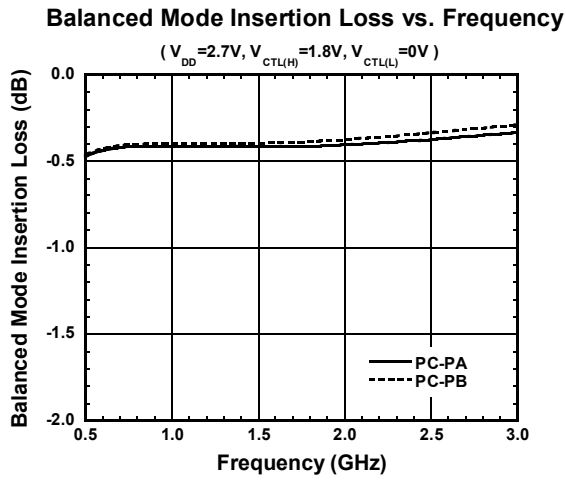

NJG1800NB2

■ ELECTRICAL CHARACTERISTICS (With application circuit, Loss of external circuit are excluded)

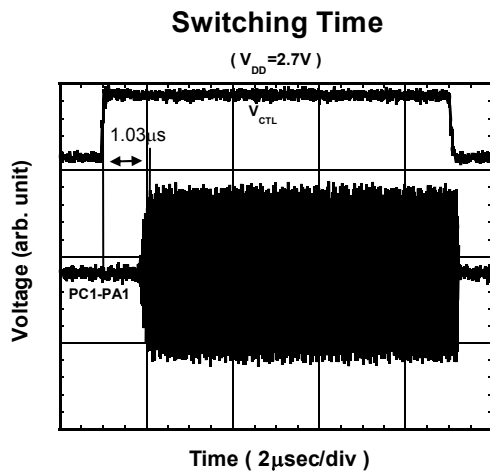
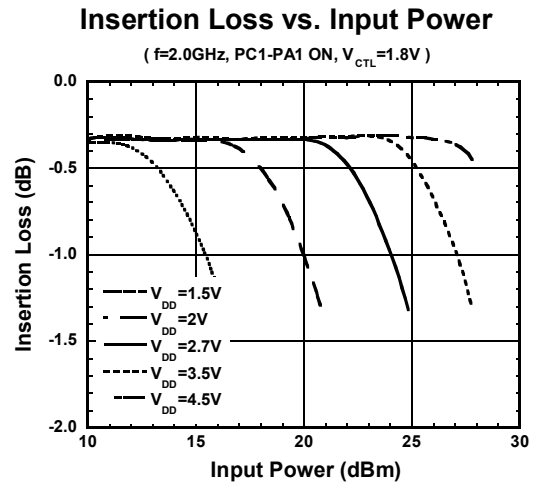
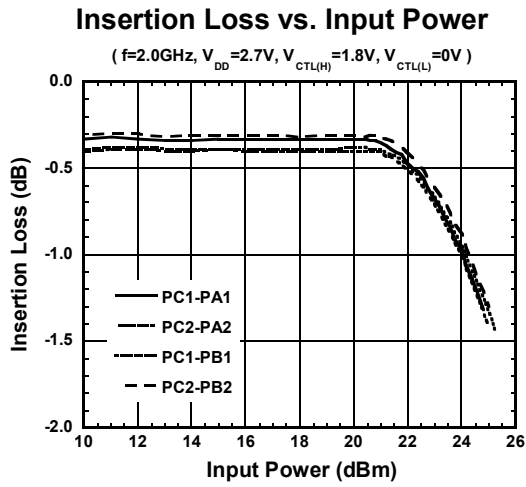

■ ELECTRICAL CHARACTERISTICS (With application circuit, Loss of external circuit are excluded)

Balanced Mode Loss, ISL vs Ambient Temperature

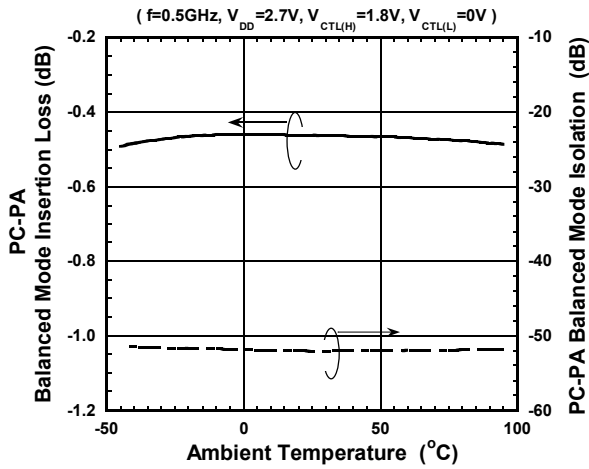

Balanced Mode Loss, ISL vs Ambient Temperature

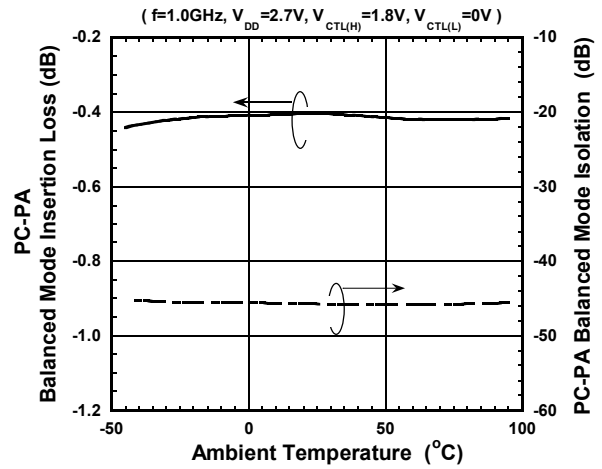

Balanced Mode Loss, ISL vs Ambient Temperature

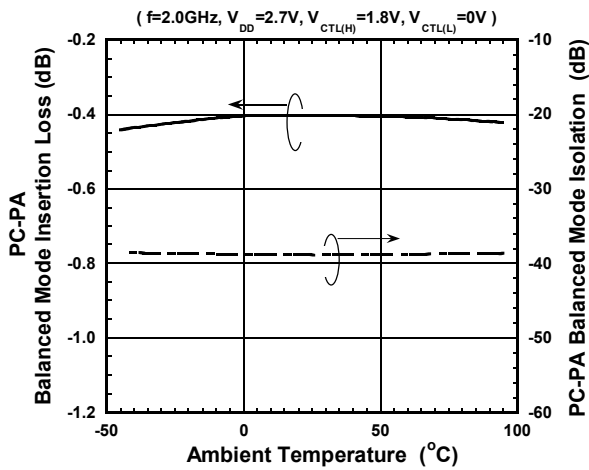

Balanced Mode Loss, ISL vs Ambient Temperature

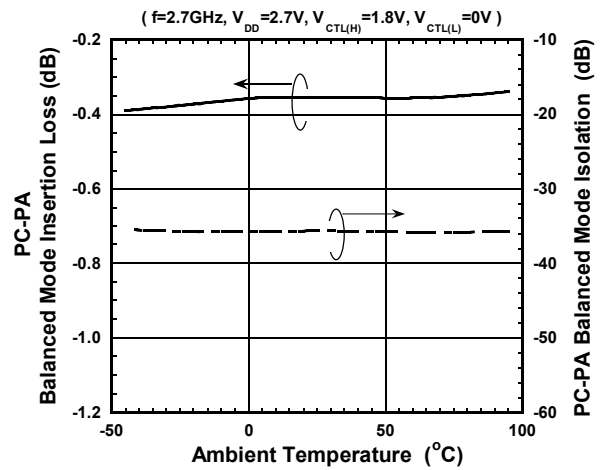

VSWR vs. Ambient Temperature

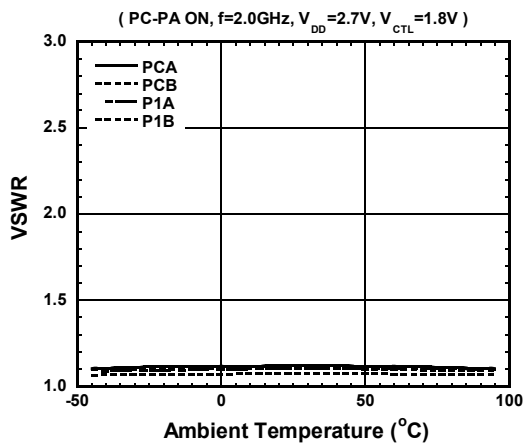

NJG1800NB2

■ ELECTRICAL CHARACTERISTICS (With application circuit, Loss of external circuit are excluded)

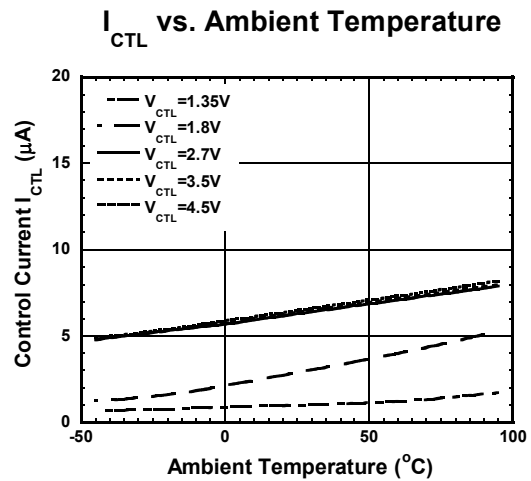
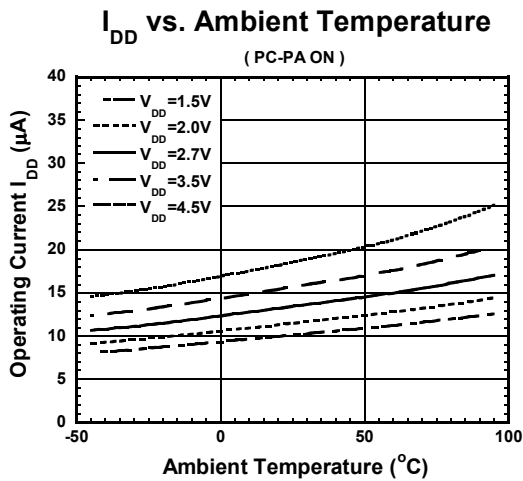
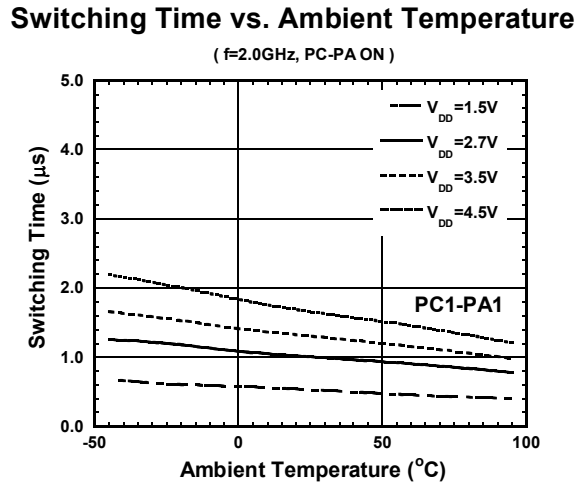
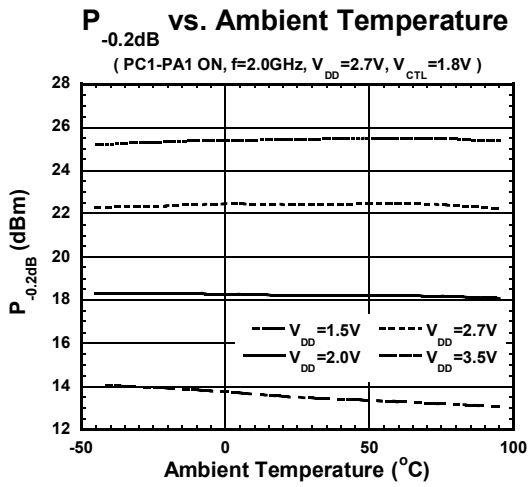

APPLICATION CIRCUIT

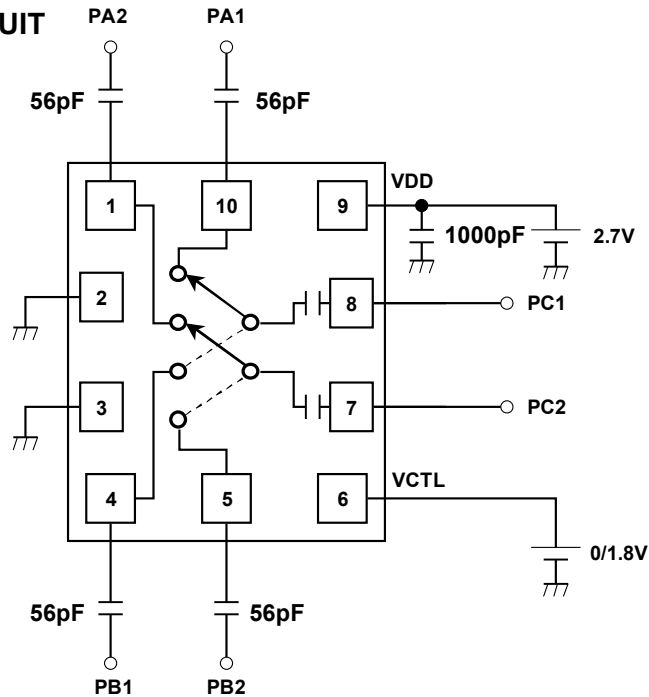

This IC has on-chip DC blocking capacitors at PC1 and PC2 ports, thereby requiring no external DC blocking capacitor for PC1 and PC2 ports. This is effective to reduce the DC blocking capacitors between the LNA port of the RFIC and corresponding X-SPDT (DP4T) switch.

PCB LAYOUT

(TOP VIEW)

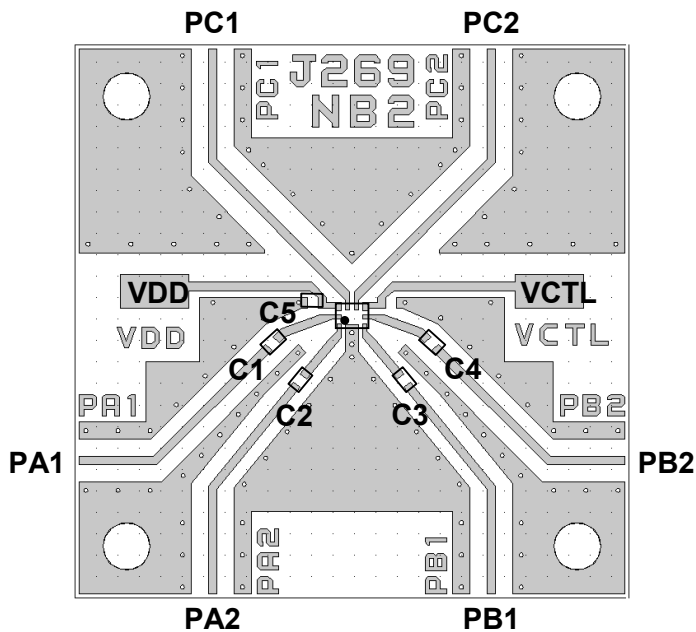

PCB: FR-4, t=0.2mm
 Capacitor Size: 1005
 Strip Line Width: 0.4mm
 PCB Size: 26 x 26mm

Losses of PCB, capacitors and connectors

Frequency (GHz)	Loss (dB)
0.5	0.21
1.0	0.34
2.0	0.51
2.7	0.67

PARTS LIST

PART ID	Value	COMMENT
C1~C4	56pF	MURATA (GRM15)
C5	1000pF	

NJG1800NB2

PCB LAYOUT (EPCSP10-B2)

(TOP VIEW)

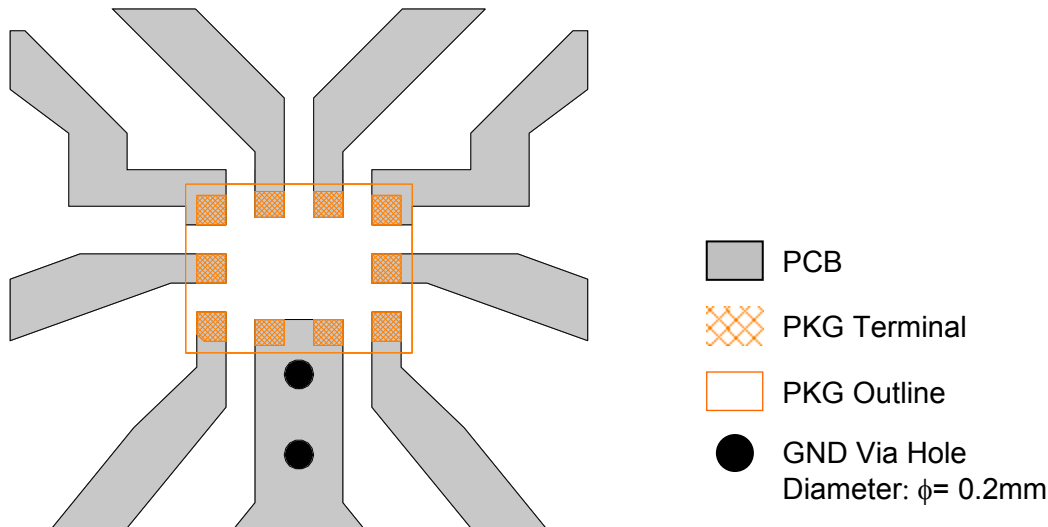

PCB LAYOUT PRECAUTIONS

- [1] The DC current at PA1, PA2, PB1 and PB2 ports must be equal to zero, which can be achieved with DC blocking capacitors (C1~C4). (However, in case there is no possibility that DC current flows, the DC blocking capacitors are unnecessary, e.g. the RF signals are fed by SAW filters that block DC current by nature, etc.)
- [2] To reduce stripline influence on RF characteristics, please locate the bypass capacitor (C5) close to VDD terminal.
- [3] For good isolation, the GND terminals must be connected to the PCB ground plane of substrate, and the through-holes connecting the backside ground plane should be placed near by the pin connection.

EXAMPLE OF TYPICAL USAGE

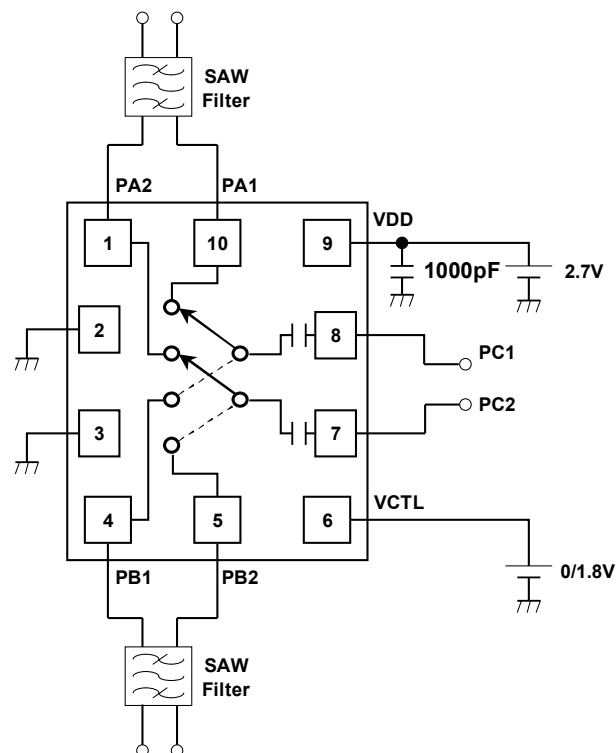

As shown in the example of typically used, no DC blocking capacitors are required at PA1, PA2, PB1 and PB2, where these ports are connected to SAW filters whose DC impedance to the ground is above 100Mohm or close to open circuited.

RECOMMENDED FOOTPRINT PATTERN (EPCSP10-B2)

PKG : 1.15mm x 1.55mm

Pin pitch : 0.4mm

 : Land

 :Mask (Open area) *Metal mask thickness : 100um

 :Resist(Open area)

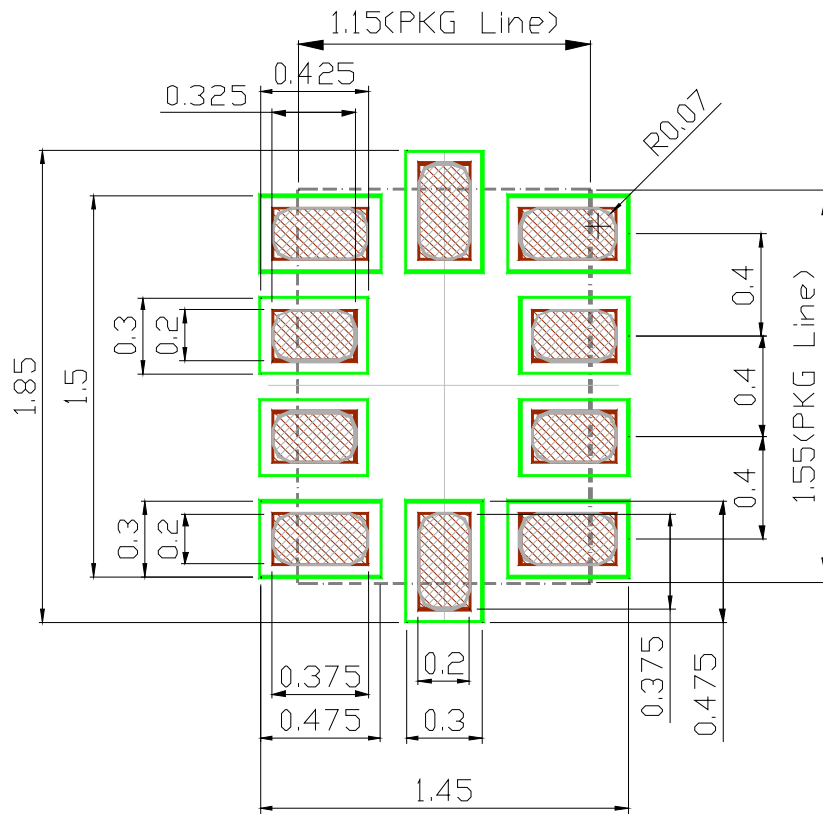

Mouser Electronics

Authorized Distributor

Click to View Pricing, Inventory, Delivery & Lifecycle Information:

[NJR:](#)

[NJG1800NB2-TE1](#)



Компания «ЭлектроПласт» предлагает заключение долгосрочных отношений при поставках импортных электронных компонентов на взаимовыгодных условиях!

Наши преимущества:

- Оперативные поставки широкого спектра электронных компонентов отечественного и импортного производства напрямую от производителей и с крупнейших мировых складов;
- Поставка более 17-ти миллионов наименований электронных компонентов;
- Поставка сложных, дефицитных, либо снятых с производства позиций;
- Оперативные сроки поставки под заказ (от 5 рабочих дней);
- Экспресс доставка в любую точку России;
- Техническая поддержка проекта, помощь в подборе аналогов, поставка прототипов;
- Система менеджмента качества сертифицирована по Международному стандарту ISO 9001;
- Лицензия ФСБ на осуществление работ с использованием сведений, составляющих государственную тайну;
- Поставка специализированных компонентов (Xilinx, Altera, Analog Devices, Intersil, Interpoint, Microsemi, Aeroflex, Peregrine, Syfer, Eurofarad, Texas Instrument, Miteq, Cobham, E2V, MA-COM, Hittite, Mini-Circuits, General Dynamics и др.);

Помимо этого, одним из направлений компании «ЭлектроПласт» является направление «Источники питания». Мы предлагаем Вам помощь Конструкторского отдела:

- Подбор оптимального решения, техническое обоснование при выборе компонента;
- Подбор аналогов;
- Консультации по применению компонента;
- Поставка образцов и прототипов;
- Техническая поддержка проекта;
- Защита от снятия компонента с производства.



Как с нами связаться

Телефон: 8 (812) 309 58 32 (многоканальный)

Факс: 8 (812) 320-02-42

Электронная почта: org@eplast1.ru

Адрес: 198099, г. Санкт-Петербург, ул. Калинина, дом 2, корпус 4, литера А.