

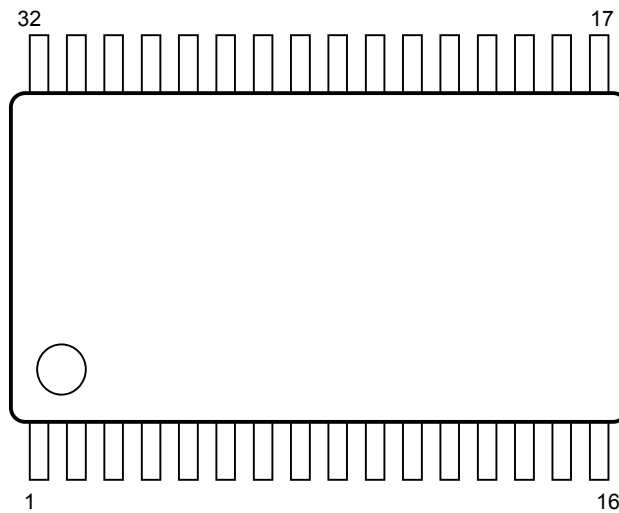

# MUSES72320

## ■ PIN FUNCTION



No.	SYMBOL	FUNCTION	No.	SYMBOL	FUNCTION
1	Z/C REFL	Lch Zero Cross Detection circuit Reference Voltage	17	D_VDD	Digital block Power Supply
2	L_REF	Lch Reference Voltage	18	DATA	Control data signal input
3	L+	Lch Opamp non-inverting input connect terminal	19	CLOCK	Clock signal input
4	L_REF	Lch Reference Voltage	20	LATCH	Latch signal input
5	L-	Lch Opamp inverting input connect terminal	21	D_REF	Digital block Reference Voltage
6	L_REF	Lch Reference Voltage	22	V+	Power Supply (+)
7	OutL	Lch output	23	InR	Rch input
8	DCCAP_L	Switching noise rejection capacitor (Lch)	24	V+	Power Supply (+)
9	DCCAP_R	Switching noise rejection capacitor (Rch)	25	V -	Power Supply (-)
10	OutR	Rch output	26	InL	Lch input
11	R_REF	Rch Reference Voltage	27	V -	Power Supply (-)
12	R-	Rch Opamp inverting input connect terminal	28	D_CAP	Digital block Noise Rejection Capacitor terminal
13	R_REF	Rch Reference Voltage	29	ADR2	Chip address setting terminal 2
14	R+	Rch Opamp non-inverting input connect terminal	30	ADR1	Chip address setting terminal 1
15	R_REF	Rch Reference Voltage	31	ADR0	Chip address setting terminal 0
16	Z/C REFR	Rch Zero Cross Detection circuit Reference Voltage	32	Z/C	Zero Cross Detection circuit ON/OFF setting terminal

## ■ ABSOLUTE MAXIMUM RATING (Ta=25°C)

PARAMETER	SYMBOL	RATING	UNIT
Power Supply Voltage	V <sub>+/-</sub>	+20/-20	V
Maximum Input Voltage	V <sub>IM</sub>	V <sub>+/-</sub>	V
Power Dissipation	P <sub>D</sub>	1000 NOTE: EIA/JEDEC STANDARD Test board (76.2x114.3x1.6mm, 2layer, FR-4) mounting	mW
Operating Temperature Range	Topr	-40 ~ +85	°C
Storage Temperature Range	Tstg	-40 ~ +125	°C

## ■ ELECTRICAL CHARACTERISTICS

PARAMETER	SYMBOL	TEST CONDITION	MIN.	TYP.	MAX.	UNIT
-----------	--------	----------------	------	------	------	------

### ◆ Power Supply (Ta=25°C, V<sub>+/-</sub>=±15V, unless otherwise specified)

Operating Voltage	V <sub>+/-</sub>		±8.5	±15.0	±18.0	V
Supply Current 1	I <sub>CC</sub>	No signal	-	2.0	10.0	mA
Supply Current 2	I <sub>EE</sub>	No signal	-	2.0	10.0	mA

### ◆ Input/Output Characteristics1 (Output)

(Ta=25°C, V<sub>+/-</sub>=±15V, V<sub>IN</sub>=2Vrms, f=1kHz, Volume=0dB, Gain=0dB, V<sub>OUT</sub> with MUSES01, R<sub>L</sub>=47kΩ, unless otherwise specified)

Maximum Input Voltage	V <sub>IM</sub>	f=1kHz, THD=1% Volume=-20dB	10.9	-	-	Vrms
Voltage Gain 1	G <sub>V1</sub>	V <sub>IN</sub> =2Vrms, f=1kHz Volume=0dB	-0.5	0	0.5	dB
Voltage Gain 2	G <sub>V2</sub>	V <sub>IN</sub> =200mVrms, f=1kHz Volume=+15dB	+14	+15	+16	dB
Voltage Gain Error 1	ΔG <sub>V1</sub>	V <sub>IN</sub> =2Vrms, f=1kHz Volume=0dB	-0.5	0	0.5	dB
Voltage Gain Error 2	ΔG <sub>V2</sub>	V <sub>IN</sub> =2Vrms, f=1kHz Volume=-60dB	-1.0	0	1.0	dB
Maximum Attenuation	A <sub>TT</sub>	V <sub>IN</sub> =4Vrms, f=1kHz Volume=-111.5dB, A-weight	-	-111.5	-	dB
Mute level	Mute	f=1kHz, V <sub>IN</sub> =4Vrms Volume=Mute, A-weight	-	-120	-	dB
Channel Separation 1	CS1	f=1kHz, V <sub>IN</sub> =2Vrms, A-weight Volume=0dB, R <sub>g</sub> =0Ω	-	-110	-90	dB
Channel Separation 2	CS2	f=20kHz, V <sub>IN</sub> =2Vrms Volume=0dB, R <sub>g</sub> =0Ω	-	-90	-	dB
Input Impedance	R <sub>IN</sub>	23pin, 26pin	14	20	-	kΩ

### ◆ Input/Output Characteristics2 (Output)

(Ta=25°C, V<sub>+/-</sub>=±15V, V<sub>IN</sub>=2Vrms, f=1kHz, Volume=0dB, Gain=0dB, V<sub>OUT</sub> with MUSES01, R<sub>L</sub>=47kΩ, unless otherwise specified)

Maximum Output Voltage	V <sub>OM</sub>	f=1kHz, THD=1% Volume=-6dB, Gain=+6dB	-	9.5	-	Vrms
Total Harmonic Distortion 1	THD1	f=1kHz, V <sub>IN</sub> =1Vrms BW=400Hz-30kHz	-	0.0005	-	%
Total Harmonic Distortion 2	THD2	f=10kHz, V <sub>IN</sub> =1Vrms BW=400Hz-30kHz	-	0.001	-	%

# MUSES72320

## ■ ELECTRICAL CHARACTERISTICS

PARAMETER	SYMBOL	TEST CONDITION	MIN.	TYP.	MAX.	UNIT
<b>◆ Input/Output Characteristics (Output)</b>						
(Ta=25°C, V <sup>+</sup> /V <sup>-</sup> =±15V, V <sub>IN</sub> =2Vrms, f=1kHz, Volume=0dB, V <sub>OUT</sub> : 3pin, 14pin, R <sub>L</sub> =100kΩ, unless otherwise specified)						
Output Noise1	V <sub>NO1</sub>	Volume=0dB, Rg=0Ω, A-weight,	-	-118 (1.26μ)	-100 (10μ)	dBV (Vrms)
Output Noise2	V <sub>NO2</sub>	Volume=-111.5dB, Rg=0Ω, A-weight,	-	-118 (1.26μ)	-	dBV (Vrms)

## ■ Logic Control Characteristics

PARAMETER	SYMBOL	TEST CONDITION	MIN.	TYP.	MAX.	UNIT
<b>◆ Digital block Power Supply Characteristics</b>						
D_VDD Terminal Input Voltage	V <sub>DVDD</sub>	17pin Terminal Input	-	-	0.8*V <sup>+</sup>	V
D_REF Terminal Input Voltage	V <sub>DREF</sub>	21pin Terminal Input	V <sup>-</sup>	-	-	V
Digital block Supply Voltage Range	V <sub>DD</sub>	V <sub>DD</sub> = V <sub>DVDD</sub> - V <sub>DREF</sub>	3.0	5.0	6.0	V

### ◆ Logic Control Terminal Characteristics

(Ta=25°C, V<sup>+</sup>/V<sup>-</sup>=±15V, V<sub>DREF</sub>=0V, unless otherwise specified)

High Level Input Voltage1	V <sub>IH1</sub>	DATA, CLOCK, LATCH	0.7*V <sub>DD</sub>	-	V <sub>DD</sub>	V
Low Level Input Voltage1	V <sub>IL1</sub>	DATA, CLOCK, LATCH	0	-	0.3*V <sub>DD</sub>	V

### ◆ Chip Address / Zero cross Terminal Characteristics

(Ta=25°C, V<sup>+</sup>/V<sup>-</sup>=±15V, V<sub>DREF</sub>=0V, unless otherwise specified)

High Level Input Voltage2	V <sub>IH2</sub>	ADR0, ADR1, ADR2, Z/C	0.7*V <sub>DD</sub>	-	V <sup>+</sup>	V
Low Level Input Voltage2	V <sub>IL2</sub>	ADR0, ADR1, ADR2, Z/C	0	-	0.3*V <sub>DD</sub>	V

## ■ TERMINAL DESCRIPTION

PIN NO.	SYMBOL	FUNCTION	EQUIVALENT CIRCUIT	TERMINAL DC VOLTAGE
23 26	InR InL	Rch input Lch input		0V
2 4 6 11 13 15	L_REF R_REF	Lch Reference Voltage Rch Reference Voltage		0V
3 14	L+ R+	Lch Opamp non-inverting input connect terminal Rch Opamp non-inverting input connect terminal		0V
5 12	L- R-	Lch Opamp inverting input connect terminal Rch Opamp inverting input connect terminal		0V

# MUSES72320

## ■ TERMINAL DESCRIPTION

PIN NO.	SYMBOL	FUNCTION	EQUIVALENT CIRCUIT	TERMINAL DC VOLTAGE
7 10	OutL OutR	Lch output Rch output		0V
8 9	DCCAP_L DCCAP_R	Switching noise rejection capacitor (Lch) Switching noise rejection capacitor (Rch)		0V
16 1	Z/C REFR Z/C REFL	Rch Zero Cross Detection circuit Reference Voltage Lch Zero Cross Detection circuit Reference Voltage		0V
18 19 20	DATA CLOCK LATCH	Control data signal input Clock signal input Latch signal input		-

## ■ TERMINAL DESCRIPTION

PIN NO.	SYMBOL	FUNCTION	EQUIVALENT CIRCUIT	TERMINAL DC VOLTAGE
21	D_REF	Digital block Reference Voltage		-
17	D_VDD	Digital block Power Supply		-
22 24	V+	Power Supply (+)		V+
32 29 30 31	Z/C ADR2 ADR1 ADR0	Zero Cross Detection circuit ON/OFF setting terminal Chip address setting terminal 2 Chip address setting terminal 1 Chip address setting terminal 0		-
28	D_CAP	Digital block Noise Rejection Capacitor terminal		0V

# MUSES72320

## TEST CIRCUIT 1

Supply Current 1 ( $I_{CC}$ ), Supply Current 1 ( $I_{EE}$ )

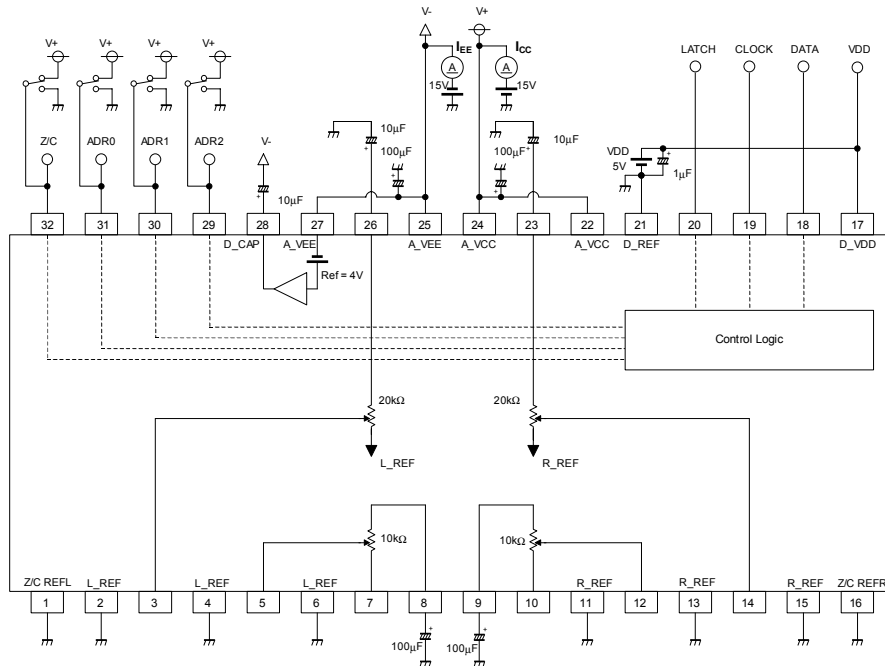

## TEST CIRCUIT 2

Maximum Input Voltage ( $V_{IM}$ ), Maximum Output Voltage ( $V_{OM}$ ), Voltage Gain 1 ( $G_{V1}$ ), Voltage Gain 2 ( $G_{V2}$ ), Maximum Attenuation ( $A_{TT}$ ), Mute level Mute), Total Harmonic Distortion 1(THD1), Total Harmonic Distortion 2(THD2)

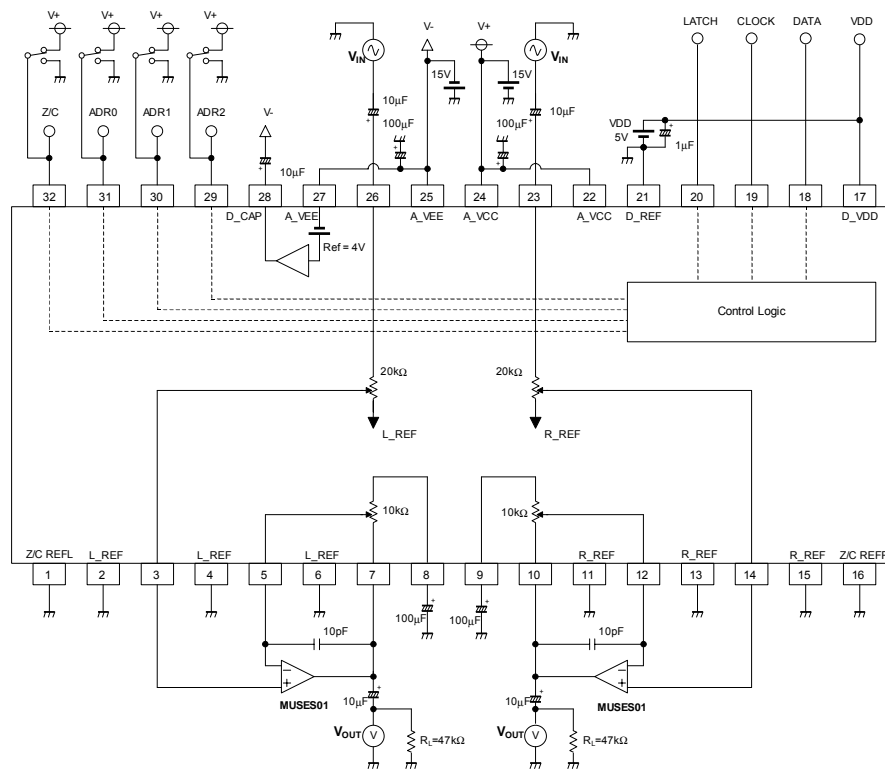





# MUSES72320

## APPLICATION CIRCUIT

<Application circuit with **J-FET** Input type OpAmp.>

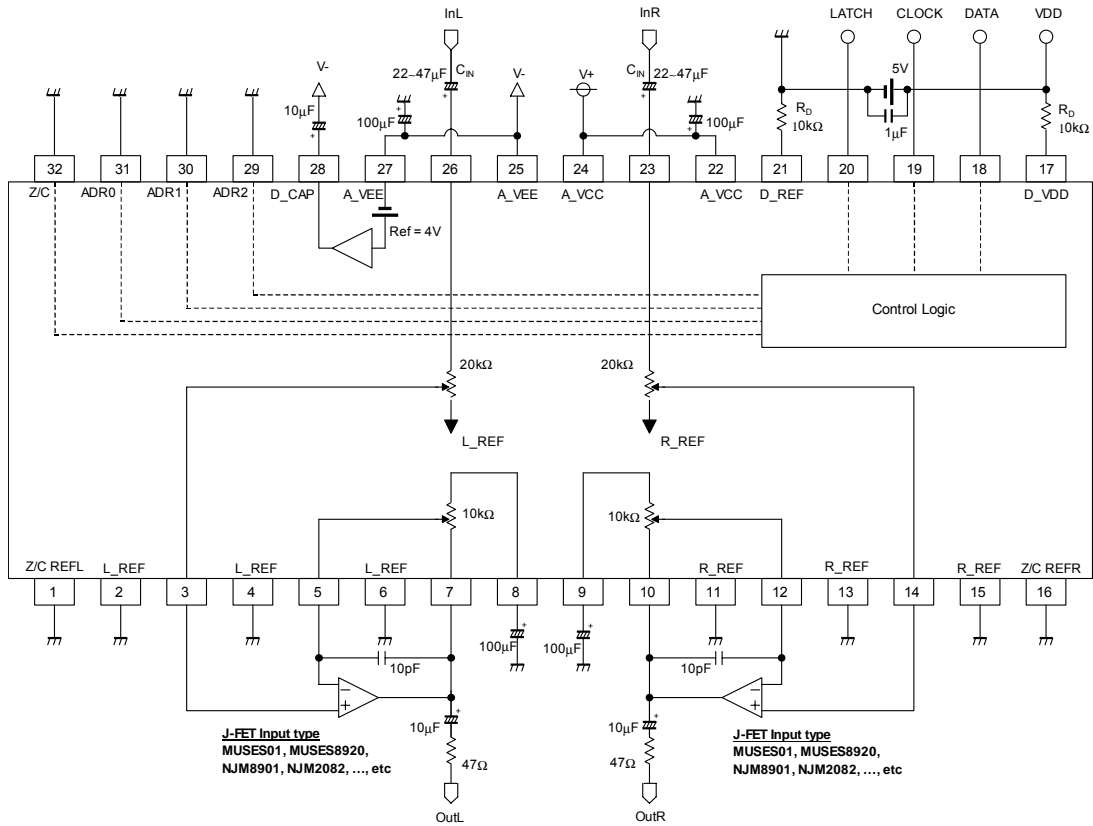

<Application circuit with **Bipolar** Input type OpAmp.>

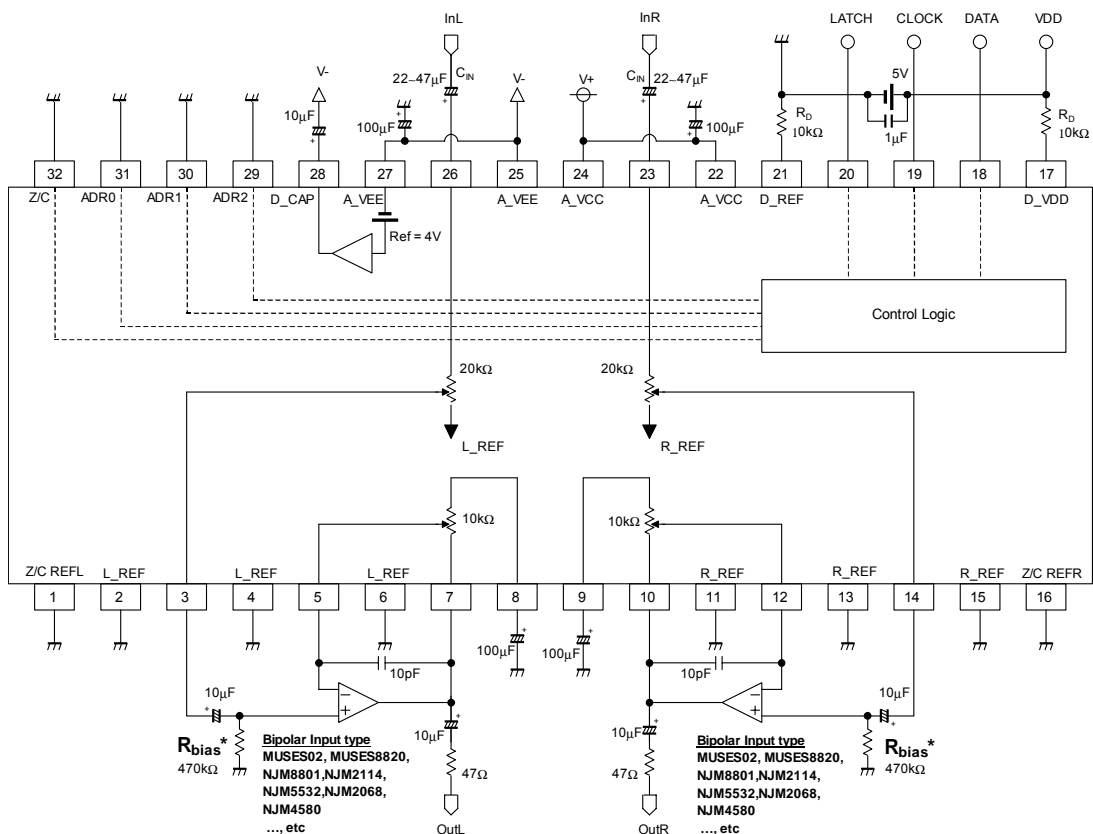

## ■ NOTES

It is necessary to adjust  $R_D$  to 10k $\Omega$  for the overcurrent protection.

The input coupling capacitors( $C_{IN}$ ) and the input resistance( $R_{IN}=20k\Omega$ ) form a high-pass filter with the corner frequency determined in  $[fc=1/(2\pi R_{IN}C_{IN})]$ .

The  $R_{bias}$  affects the Volume(Att.) linearity characteristic. When  $R_{bias}$  value is too small, the amount of attenuation increases, so that the output amplitude becomes small and THD deteriorates by an internal analog switch. On the other hand, when  $R_{bias}$  is too large, it may be affected at the noise from the outside. Please decide resistance value after it verifies it enough by an actual application.

Separate for REF terminals for High and Middle voltage(AC) and REF terminals for Low voltage(AC) in the pattern design.

Pin No.	Function	Purpose
2	Lch Reference Voltage	for Low voltage(AC) signal
4	Lch Reference Voltage	for Middle voltage(AC) signal
6	Lch Reference Voltage	for High voltage(AC) signal
11	Rch Reference Voltage	for High voltage(AC) signal
13	Rch Reference Voltage	for Middle voltage(AC) signal
15	Rch Reference Voltage	for Low voltage(AC) signal

Table.1 Purpose of Reference Voltage Terminal

# MUSES72320

## ■ CONTROL DATA FORMAT

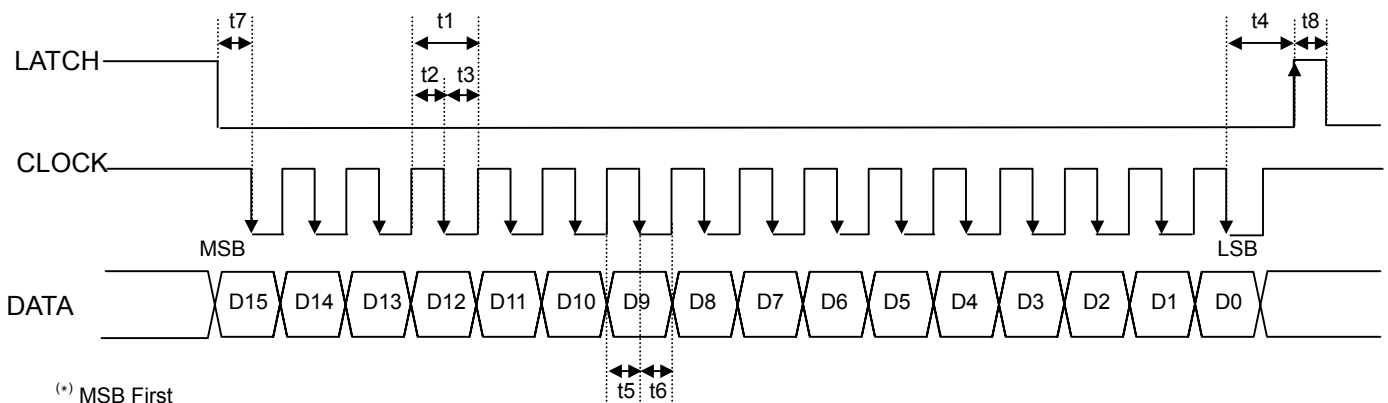

Note.) Set CLOCK in High to prevent incorrect operation during a standby period.

SYMBOL	PARAMETER	MIN	TYP	MAX	UNIT
t1	CLOCK Clock Width	4	-	-	μsec
t2	CLOCK Pulse Width (High)	2	-	-	μsec
t3	CLOCK Pulse Width (Low)	2	-	-	μsec
t4	LATCH Rise Hold Time	4	-	-	μsec
t5	DATA Setup Time	1.6	-	-	μsec
t6	DATA Hold Time	1.6	-	-	μsec
t7	CLOCK Setup Time	1.6	-	-	μsec
t8	LATCH High Pulse Width	1.6	-	-	μsec

## ■ CONTROL DATA

MUSES72320 control data is constructed with 16bits.

MSB														LSB	
D15	D14	D13	D12	D11	D10	D9	D8	D7	D6	D5	D4	D3	D2	D1	D0
Data								Select Address				Chip Address			

MSB														LSB	
D15	D14	D13	D12	D11	D10	D9	D8	D7	D6	D5	D4	D3	D2	D1	D0
Lch Volume Control (Att.)								0	0	0	0	0	*	*	*
0	0	Lch Volume Control (Gain)						0	0	0	1	0	*	*	*
Rch Volume Control (Att.)								0	0	1	0	0	*	*	*
0	0	Rch Volume Control (Gain)						0	0	1	1	0	*	*	*
L/R Cont 1	L/R Cont 2	Z/C	Don't Care	Don't Care	Don't Care	Don't Care	Don't Care	0	1	0	0	0	*	*	*

\* Chip address is set by chip address select terminals (ADR0, ADR1, ADR2) status.

Chip address select terminal			Chip address			
ADR2 (31pin)	ADR1 (30pin)	ADR0 (29pin)	D3	D2	D1	D0
Low	Low	Low	0	0	0	0
Low	Low	High	0	0	0	1
Low	High	Low	0	0	1	0
Low	High	High	0	0	1	1
High	Low	Low	0	1	0	0
High	Low	High	0	1	0	1
High	High	Low	0	1	1	0
High	High	High	0	1	1	1

## ■ INITIAL CONDITION

MSB														LSB	
D15	D14	D13	D12	D11	D10	D9	D8	D7	D6	D5	D4	D3	D2	D1	D0
0	0	0	0	0	0	0	0	0	0	0	0	0	*	*	*
0	0	0	0	0	0	0	0	0	0	0	1	0	*	*	*
0	0	0	0	0	0	0	0	0	0	1	0	0	*	*	*
0	0	0	0	0	0	0	0	0	0	1	1	0	*	*	*
0	0	0	0	0	0	0	0	0	1	0	0	0	*	*	*

Note.) This product starts up by MUTE setting in power "ON". Use it after removing MUTE of each setting.

If any audio signal is inputted in input signal terminal before power "ON", it may cause initial condition abnormality.

In conditions of use such as the above, it prevents that abnormality by setting MUTE before power "OFF"

# MUSES72320

## ■ DEFINITION OF RESISTOR

◆Volume Control (Att.) : 0dB to -111.5dB / 0.5dBstep.

: Lch Volume and Rch Volume are controlled independently when L/R Cont 1 = "0".

D15	D14	D13	D12	D11	D10	D9	D8	D7	D6	D5	D4	D3	D2	D1	D0
Lch Volume Control (Att.)								0	0	0	0	*	*	*	*
Rch Volume Control (Att.)								0	0	1	0	*	*	*	*

< Volume Control Data >

Data								Setting
D15	D14	D13	D12	D11	D10	D9	D8	
0	0	0	0	0	0	0	0	Mute <sup>(*)</sup>
0	0	0	1	0	0	0	0	0dB
0	0	0	1	0	0	0	1	-0.5dB
0	0	0	1	0	0	1	0	-1.0dB
0	0	0	1	0	0	1	1	-1.5dB
0	0	0	1	0	1	0	0	-2.0dB
0	0	0	1	0	1	0	1	-2.5dB
0	0	0	1	0	1	1	0	-3.0dB
0	0	0	1	0	1	1	1	-3.5dB
0	0	0	1	1	0	0	0	-4.0dB
0	0	0	1	1	0	0	1	-4.5dB
0	0	0	1	1	0	1	0	-5.0dB
0	0	0	1	1	0	1	1	-5.5dB
0	0	0	1	1	1	0	0	-6.0dB
0	0	0	1	1	1	0	1	-6.5dB
0	0	0	1	1	1	1	0	-7.0dB
0	0	0	1	1	1	1	1	-7.5dB
0	0	1	0	0	0	0	0	-8.0dB
0	0	1	0	0	0	0	1	-8.5dB
0	0	1	0	0	0	1	0	-9.0dB
0	0	1	0	0	0	1	1	-9.5dB
0	0	1	0	0	1	0	0	-10.0dB
0	0	1	0	0	1	0	1	-10.5dB
0	0	1	0	0	1	1	0	-11.0dB
0	0	1	0	0	1	1	1	-11.5dB
0	0	1	0	1	0	0	0	-12.0dB
0	0	1	0	1	0	0	1	-12.5dB
0	0	1	0	1	0	1	0	-13.0dB
0	0	1	0	1	0	1	1	-13.5dB
0	0	1	0	1	1	0	0	-14.0dB
0	0	1	0	1	1	0	1	-14.5dB
0	0	1	0	1	1	1	0	-15.0dB
0	0	1	0	1	1	1	1	-15.5dB
0	0	1	1	0	0	0	0	-16.0dB
0	0	1	1	0	0	0	1	-16.5dB
0	0	1	1	0	0	1	0	-17.0dB
0	0	1	1	0	0	1	1	-17.5dB
0	0	1	1	0	1	0	0	-18.0dB
0	0	1	1	0	1	0	1	-18.5dB
0	0	1	1	0	1	1	0	-19.0dB
0	0	1	1	0	1	1	1	-19.5dB
0	0	1	1	1	0	0	0	-20.0dB
0	0	1	1	1	0	0	1	-20.5dB
0	0	1	1	1	0	1	0	-21.0dB
0	0	1	1	1	0	1	1	-21.5dB
0	0	1	1	1	1	0	0	-22.0dB
0	0	1	1	1	1	0	1	-22.5dB
0	0	1	1	1	1	1	0	-23.0dB
0	0	1	1	1	1	1	1	-23.5dB

< Volume Control Data >

Data								Setting
D15	D14	D13	D12	D11	D10	D9	D8	
0	1	0	0	0	0	0	0	-24.0dB
0	1	0	0	0	0	0	1	-24.5dB
0	1	0	0	0	0	1	0	-25.0dB
0	1	0	0	0	0	1	1	-25.5dB
0	1	0	0	0	1	0	0	-26.0dB
0	1	0	0	0	1	0	1	-26.5dB
0	1	0	0	0	1	1	0	-27.0dB
0	1	0	0	0	1	1	1	-27.5dB
0	1	0	0	1	0	0	0	-28.0dB
0	1	0	0	1	0	0	1	-28.5dB
0	1	0	0	1	0	1	0	-29.0dB
0	1	0	0	1	0	1	1	-29.5dB
0	1	0	0	1	1	0	0	-30.0dB
0	1	0	0	1	1	0	1	-30.5dB
0	1	0	0	1	1	1	0	-31.0dB
0	1	0	0	1	1	1	1	-31.5dB
0	1	0	1	0	0	0	0	-32.0dB
0	1	0	1	0	0	0	1	-32.5dB
0	1	0	1	0	0	1	0	-33.0dB
0	1	0	1	0	0	1	1	-33.5dB
0	1	0	1	0	1	0	0	-34.0dB
0	1	0	1	0	1	0	1	-34.5dB
0	1	0	1	0	1	1	0	-35.0dB
0	1	0	1	0	1	1	1	-35.5dB
0	1	0	1	1	0	0	0	-36.0dB
0	1	0	1	1	0	0	1	-36.5dB
0	1	0	1	1	0	1	0	-37.0dB
0	1	0	1	1	0	1	1	-37.5dB
0	1	0	1	1	1	0	0	-38.0dB
0	1	0	1	1	1	0	1	-38.5dB
0	1	0	1	1	1	1	0	-39.0dB
0	1	0	1	1	1	1	1	-39.5dB
0	1	1	0	0	0	0	0	-40.0dB
0	1	1	0	0	0	0	1	-40.5dB
0	1	1	0	0	0	1	0	-41.0dB
0	1	1	0	0	0	1	1	-41.5dB
0	1	1	0	0	1	0	0	-42.0dB
0	1	1	0	0	1	0	1	-42.5dB
0	1	1	0	0	1	1	0	-43.0dB
0	1	1	0	0	1	1	1	-43.5dB
0	1	1	0	1	0	0	0	-44.0dB
0	1	1	0	1	0	0	1	-44.5dB
0	1	1	0	1	0	1	0	-45.0dB
0	1	1	0	1	0	1	1	-45.5dB
0	1	1	0	1	1	0	0	-46.0dB
0	1	1	0	1	1	0	1	-46.5dB
0	1	1	0	1	1	1	0	-47.0dB
0	1	1	0	1	1	1	1	-47.5dB

# MUSES72320

< Volume Control Data >

Data								Setting
D15	D14	D13	D12	D11	D10	D9	D8	
0	1	1	1	0	0	0	0	-48.0dB
0	1	1	1	0	0	0	1	-48.5dB
0	1	1	1	0	0	1	0	-49.0dB
0	1	1	1	0	0	1	1	-49.5dB
0	1	1	1	0	1	0	0	-50.0dB
0	1	1	1	0	1	0	1	-50.5dB
0	1	1	1	0	1	1	0	-51.0dB
0	1	1	1	0	1	1	1	-51.5dB
0	1	1	1	1	0	0	0	-52.0dB
0	1	1	1	1	0	0	1	-52.5dB
0	1	1	1	1	0	1	0	-53.0dB
0	1	1	1	1	0	1	1	-53.5dB
0	1	1	1	1	1	0	0	-54.0dB
0	1	1	1	1	1	0	1	-54.5dB
0	1	1	1	1	1	1	0	-55.0dB
0	1	1	1	1	1	1	1	-55.5dB
1	0	0	0	0	0	0	0	-56.0dB
1	0	0	0	0	0	0	1	-56.5dB
1	0	0	0	0	0	1	0	-57.0dB
1	0	0	0	0	0	1	1	-57.5dB
1	0	0	0	0	1	0	0	-58.0dB
1	0	0	0	0	1	0	1	-58.5dB
1	0	0	0	0	1	1	0	-59.0dB
1	0	0	0	0	1	1	1	-59.5dB
1	0	0	0	1	0	0	0	-60.0dB
1	0	0	0	1	0	0	1	-60.5dB
1	0	0	0	1	0	1	0	-61.0dB
1	0	0	0	1	0	1	1	-61.5dB
1	0	0	0	1	1	0	0	-62.0dB
1	0	0	0	1	1	0	1	-62.5dB
1	0	0	0	1	1	1	0	-63.0dB
1	0	0	0	1	1	1	1	-63.5dB
1	0	0	1	0	0	0	0	-64.0dB
1	0	0	1	0	0	0	1	-64.5dB
1	0	0	1	0	0	1	0	-65.0dB
1	0	0	1	0	0	1	1	-65.5dB
1	0	0	1	0	1	0	0	-66.0dB
1	0	0	1	0	1	0	1	-66.5dB
1	0	0	1	0	1	1	0	-67.0dB
1	0	0	1	0	1	1	1	-67.5dB
1	0	0	1	1	0	0	0	-68.0dB
1	0	0	1	1	0	0	1	-68.5dB
1	0	0	1	1	0	1	0	-69.0dB
1	0	0	1	1	0	1	1	-69.5dB
1	0	0	1	1	1	0	0	-70.0dB
1	0	0	1	1	1	0	1	-70.5dB
1	0	0	1	1	1	1	0	-71.0dB
1	0	0	1	1	1	1	1	-71.5dB



< Volume Control Data >

Data								Setting
D15	D14	D13	D12	D11	D10	D9	D8	
1	0	1	0	0	0	0	0	-72.0dB
1	0	1	0	0	0	0	1	-72.5dB
1	0	1	0	0	0	1	0	-73.0dB
1	0	1	0	0	0	1	1	-73.5dB
1	0	1	0	0	1	0	0	-74.0dB
1	0	1	0	0	1	0	1	-74.5dB
1	0	1	0	0	1	1	0	-75.0dB
1	0	1	0	0	1	1	1	-75.5dB
1	0	1	0	1	0	0	0	-76.0dB
1	0	1	0	1	0	0	1	-76.5dB
1	0	1	0	1	0	1	0	-77.0dB
1	0	1	0	1	0	1	1	-77.5dB
1	0	1	0	1	1	0	0	-78.0dB
1	0	1	0	1	1	0	1	-78.5dB
1	0	1	0	1	1	1	0	-79.0dB
1	0	1	0	1	1	1	1	-79.5dB
1	0	1	1	0	0	0	0	-80.0dB
1	0	1	1	0	0	0	1	-80.5dB
1	0	1	1	0	0	1	0	-81.0dB
1	0	1	1	0	0	1	1	-81.5dB
1	0	1	1	0	1	0	0	-82.0dB
1	0	1	1	0	1	0	1	-82.5dB
1	0	1	1	0	1	1	0	-83.0dB
1	0	1	1	0	1	1	1	-83.5dB
1	0	1	1	1	0	0	0	-84.0dB
1	0	1	1	1	0	0	1	-84.5dB
1	0	1	1	1	0	1	0	-85.0dB
1	0	1	1	1	0	1	1	-85.5dB
1	0	1	1	1	1	0	0	-86.0dB
1	0	1	1	1	1	0	1	-86.5dB
1	0	1	1	1	1	1	0	-87.0dB
1	0	1	1	1	1	1	1	-87.5dB
1	1	0	0	0	0	0	0	-88.0dB
1	1	0	0	0	0	0	1	-88.5dB
1	1	0	0	0	0	1	0	-89.0dB
1	1	0	0	0	0	1	1	-89.5dB
1	1	0	0	0	1	0	0	-90.0dB
1	1	0	0	0	1	0	1	-90.5dB
1	1	0	0	0	1	1	0	-91.0dB
1	1	0	0	0	1	1	1	-91.5dB
1	1	0	0	1	0	0	0	-92.0dB
1	1	0	0	1	0	0	1	-92.5dB
1	1	0	0	1	0	1	0	-93.0dB
1	1	0	0	1	0	1	1	-93.5dB
1	1	0	0	1	1	0	0	-94.0dB
1	1	0	0	1	1	0	1	-94.5dB
1	1	0	0	1	1	1	0	-95.0dB
1	1	0	0	1	1	1	1	-95.5dB

# MUSES72320

## < Volume Control Data >

Data								Setting
D15	D14	D13	D12	D11	D10	D9	D8	
1	1	0	1	0	0	0	0	-96.0dB
1	1	0	1	0	0	0	1	-96.5dB
1	1	0	1	0	0	1	0	-97.0dB
1	1	0	1	0	0	1	1	-97.5dB
1	1	0	1	0	1	0	0	-98.0dB
1	1	0	1	0	1	0	1	-98.5dB
1	1	0	1	0	1	1	0	-99.0dB
1	1	0	1	0	1	1	1	-99.5dB
1	1	0	1	1	0	0	0	-100.0dB
1	1	0	1	1	0	0	1	-100.5dB
1	1	0	1	1	0	1	0	-101.0dB
1	1	0	1	1	0	1	1	-101.5dB
1	1	0	1	1	1	0	0	-102.0dB
1	1	0	1	1	1	0	1	-102.5dB
1	1	0	1	1	1	1	0	-103.0dB
1	1	0	1	1	1	1	1	-103.5dB
1	1	1	0	0	0	0	0	-104.0dB
1	1	1	0	0	0	0	1	-104.5dB
1	1	1	0	0	0	1	0	-105.0dB
1	1	1	0	0	0	1	1	-105.5dB
1	1	1	0	0	1	0	0	-106.0dB
1	1	1	0	0	1	0	1	-106.5dB
1	1	1	0	0	1	1	0	-107.0dB
1	1	1	0	0	1	1	1	-107.5dB
1	1	1	0	1	0	0	0	-108.0dB
1	1	1	0	1	0	0	1	-108.5dB
1	1	1	0	1	0	1	0	-109.0dB
1	1	1	0	1	0	1	1	-109.5dB
1	1	1	0	1	1	0	0	-110.0dB
1	1	1	0	1	1	0	1	-110.5dB
1	1	1	0	1	1	1	0	-111.0dB
1	1	1	0	1	1	1	1	-111.5dB
1	1	1	1	1	1	1	1	Mute

(\*)Initial Setting

◆Volume Control (Gain.) : +31.5dB to 0dB / 0.5dBstep.

: Lch Volume and Rch Volume are controlled independently when L/R Cont 2 = "0".

D15	D14	D13	D12	D11	D10	D9	D8	D7	D6	D5	D4	D3	D2	D1	D0
0	0	Lch Volume Control (Gain)						0	0	0	1	0	*	*	*
0	0	Rch Volume Control (Gain)						0	0	1	1	0	*	*	*

< Volume Control Data >

Data							Setting
D14	D13	D12	D11	D10	D9	D8	
0	0	0	0	0	0	0	0dB <sup>(+)</sup>
1	0	0	0	0	0	0	+0.25dB
0	0	0	0	0	0	1	+0.5dB
0	0	0	0	0	1	0	+1.0dB
0	0	0	0	0	1	1	+1.5dB
0	0	0	0	1	0	0	+2.0dB
0	0	0	0	1	0	1	+2.5dB
0	0	0	0	1	1	0	+3.0dB
0	0	0	0	1	1	1	+3.5dB
0	0	0	1	0	0	0	+4.0dB
0	0	0	1	0	0	1	+4.5dB
0	0	0	1	0	1	0	+5.0dB
0	0	0	1	0	1	1	+5.5dB
0	0	0	1	1	0	0	+6.0dB
0	0	0	1	1	0	1	+6.5dB
0	0	0	1	1	1	0	+7.0dB
0	0	0	1	1	1	1	+7.5dB
0	0	1	0	0	0	0	+8.0dB
1	0	1	0	0	0	0	+8.25dB
0	0	1	0	0	0	1	+8.5dB
0	0	1	0	0	1	0	+9.0dB
0	0	1	0	0	1	1	+9.5dB
0	0	1	0	1	0	0	+10.0dB
0	0	1	0	1	0	1	+10.5dB
0	0	1	0	1	1	0	+11.0dB
0	0	1	0	1	1	1	+11.5dB
0	0	1	1	0	0	0	+12.0dB
0	0	1	1	0	0	1	+12.5dB
0	0	1	1	0	1	0	+13.0dB
0	0	1	1	0	1	1	+13.5dB
0	0	1	1	1	0	0	+14.0dB
0	0	1	1	1	0	1	+14.5dB
0	0	1	1	1	1	0	+15.0dB
0	0	1	1	1	1	1	+15.5dB
0	1	0	0	0	0	0	+16.0dB
1	1	0	0	0	0	0	+16.25dB
0	1	0	0	0	0	1	+16.5dB
0	1	0	0	0	1	0	+17.0dB
0	1	0	0	0	1	1	+17.5dB
0	1	0	0	1	0	0	+18.0dB
0	1	0	0	1	0	1	+18.5dB
0	1	0	0	1	1	0	+19.0dB
0	1	0	0	1	1	1	+19.5dB
0	1	0	1	0	0	0	+20.0dB
0	1	0	1	0	0	1	+20.5dB
0	1	0	1	0	1	0	+21.0dB
0	1	0	1	0	1	1	+21.5dB
0	1	0	1	1	0	0	+22.0dB
0	1	0	1	1	0	1	+22.5dB
0	1	0	1	1	1	0	+23.0dB
0	1	0	1	1	1	1	+23.5dB

# MUSES72320

## < Volume Control Data >

Data							Setting
D14	D13	D12	D11	D10	D9	D8	
0	1	1	0	0	0	0	+24.0dB
1	1	1	0	0	0	0	+24.25dB
0	1	1	0	0	0	1	+24.5dB
0	1	1	0	0	1	0	+25.0dB
0	1	1	0	0	1	1	+25.5dB
0	1	1	0	1	0	0	+26.0dB
0	1	1	0	1	0	1	+26.5dB
0	1	1	0	1	1	0	+27.0dB
0	1	1	0	1	1	1	+27.5dB
0	1	1	1	0	0	0	+28.0dB
0	1	1	1	0	0	1	+28.5dB
0	1	1	1	0	1	0	+29.0dB
0	1	1	1	0	1	1	+29.5dB
0	1	1	1	1	0	0	+30.0dB
0	1	1	1	1	0	1	+30.5dB
0	1	1	1	1	1	0	+31.0dB
0	1	1	1	1	1	1	+31.5dB

(\*)Initial Setting

- ◆L/R Cont 1 : Select " the independent control" or " the Lch-Rch link control" of the method of the volume control (Att).
- L/R Cont 2 : Select " the independent control" or " the Lch-Rch link control" of the method of the volume control (Gain).
- Z/C : Zero Cross Detection circuit ON/OFF setting

D15	D14	D13	D12	D11	D10	D9	D8	D7	D6	D5	D4	D3	D2	D1	D0
L/R Cont 1	L/R Cont 2	Z/C	Don't Care	Don't Care	Don't Care	TEST	TEST	0	1	0	0	0	*	*	*

### <L/R Cont 1 : Method of the volume control (Att).>

D15	Setting
0	Lch, Rch independent control (*)
1	Lch-Rch link control

(\*)Initial Setting

### <L/R Cont 2 : Method of the volume control (Gain).>

D14	Setting
0	Lch, Rch independent control (*)
1	Lch-Rch link control

(\*)Initial Setting

### \* Command table when Lch, Rch interconnected control

D15	D14	D13	D12	D11	D10	D9	D8	D7	D6	D5	D4	D3	D2	D1	D0
Lch-Rch link control (Att.)								0	0	0	0	0	*	*	*
Lch-Rch link control (Gain)								0	0	0	1	0	*	*	*
No Acceptable								0	0	1	0	0	*	*	*
No Acceptable								0	0	1	1	0	*	*	*

<Z/C : Zero Cross Detection circuit ON/OFF setting >

D13	Setting
0	Zero Cross Detection circuit: ON <sup>(*)</sup>
1	Zero Cross Detection circuit: OFF

<sup>(\*)</sup>Initial Setting

\* Zero cross detection circuit is ON When "Z/C terminal = Low" and "Z/C bit =0" are set.

		Z/C bit ("D13")	
		0	1
Z/C terminal (32pin)	Low	Zero Cross Detection circuit : ON	Zero Cross Detection circuit : OFF
	High	Zero Cross Detection circuit : OFF	Zero Cross Detection circuit : OFF

# MUSES72320

## ◆Volume Control (Att) +0.25dB to -111.5dB(0.25dB/step) setting example

Using Volume Control(Gain) +0.25dB enables to set 0.25dB/step in the range of +0.25dB to -111.5dB.  
(+8.25dB, +16.25, +24.25 also can be used)

< Volume Control Data >

Lch / Rch Volume Control (Gain)							Lch / Rch Volume Control (Att)								Gain Setting
D14	D13	D12	D11	D10	D9	D8	D15	D14	D13	D12	D11	D10	D9	D8	
0	1	1	1	1	1	1	0	0	0	1	0	0	0	0	+31.5dB
0	1	1	1	1	1	0	0	0	0	1	0	0	0	0	+31.0dB
0	1	1	1	1	0	1	0	0	0	1	0	0	0	0	+30.5dB
0	1	1	1	1	0	0	0	0	0	1	0	0	0	0	+30.0dB
0	1	1	1	0	1	1	0	0	0	1	0	0	0	0	+29.5dB
0	1	1	1	0	1	0	0	0	0	1	0	0	0	0	+29.0dB
0	1	1	1	0	0	1	0	0	0	1	0	0	0	0	+28.5dB
0	1	1	1	0	0	0	0	0	0	1	0	0	0	0	+28.0dB
0	1	1	0	1	1	1	0	0	0	1	0	0	0	0	+27.5dB
0	1	1	0	1	1	0	0	0	0	1	0	0	0	0	+27.0dB
:							:								:
:							:								:
0	0	0	0	1	0	0	0	0	0	1	0	0	0	0	+2.0dB
0	0	0	0	0	1	1	0	0	0	1	0	0	0	0	+1.5dB
0	0	0	0	0	1	0	0	0	0	1	0	0	0	0	+1.0dB
0	0	0	0	0	0	1	0	0	0	1	0	0	0	0	+0.5dB
1	0	0	0	0	0	0	0	0	0	1	0	0	0	0	+0.25dB
0	0	0	0	0	0	0	0	0	0	1	0	0	0	0	+0dB
1	0	0	0	0	0	0	0	0	0	1	0	0	0	1	-0.25dB
0	0	0	0	0	0	0	0	0	0	1	0	0	0	1	-0.5dB
1	0	0	0	0	0	0	0	0	0	1	0	0	1	0	-0.75dB
0	0	0	0	0	0	0	0	0	0	1	0	0	1	0	-1.0dB
1	0	0	0	0	0	0	0	0	0	1	0	0	1	1	-1.25dB
0	0	0	0	0	0	0	0	0	0	1	0	0	1	1	-1.5dB
1	0	0	0	0	0	0	0	0	0	1	0	1	0	0	-1.75dB
0	0	0	0	0	0	0	0	0	0	1	0	1	0	0	-2.0dB
1	0	0	0	0	0	0	0	0	0	1	0	1	0	1	-2.25dB
0	0	0	0	0	0	0	0	0	0	1	0	1	0	1	-2.5dB
1	0	0	0	0	0	0	0	0	0	1	0	1	1	0	-2.75dB
0	0	0	0	0	0	0	0	0	0	1	0	1	1	0	-3.0dB
1	0	0	0	0	0	0	0	0	0	1	0	1	1	1	-3.25dB
0	0	0	0	0	0	0	0	0	0	1	0	1	1	1	-3.5dB
1	0	0	0	0	0	0	0	0	0	1	1	0	0	0	-3.75dB
0	0	0	0	0	0	0	0	0	0	1	1	0	0	0	-4.0dB
1	0	0	0	0	0	0	0	0	0	1	1	0	0	1	-4.25dB
0	0	0	0	0	0	0	0	0	0	1	1	0	0	1	-4.5dB
1	0	0	0	0	0	0	0	0	0	1	1	0	1	0	-4.75dB
0	0	0	0	0	0	0	0	0	0	1	1	0	1	0	-5.0dB
1	0	0	0	0	0	0	0	0	0	1	1	0	1	1	-5.25dB
0	0	0	0	0	0	0	0	0	0	1	1	0	1	1	-5.5dB
1	0	0	0	0	0	0	0	0	0	1	1	1	0	0	-5.75dB
0	0	0	0	0	0	0	0	0	0	1	1	1	0	0	-6.0dB
:							:								:
:							:								:
1	0	0	0	0	0	0	1	1	1	0	1	1	0	1	-110.25dB
0	0	0	0	0	0	0	1	1	1	0	1	1	0	1	-110.5dB
1	0	0	0	0	0	0	1	1	1	0	1	1	1	0	-110.75dB
0	0	0	0	0	0	0	1	1	1	0	1	1	1	0	-111.0dB
1	0	0	0	0	0	0	1	1	1	0	1	1	1	1	-111.25dB
0	0	0	0	0	0	0	1	1	1	0	1	1	1	1	-111.5dB
0	0	0	0	0	0	0	1	1	1	1	1	1	1	1	Mute

## ■ TYPICAL CHARACTERISTICS

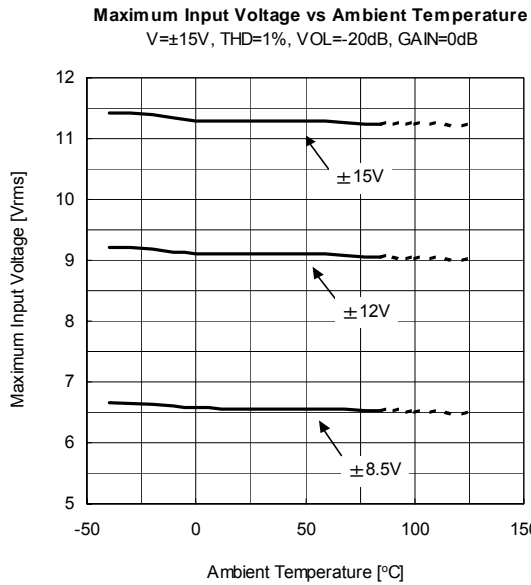
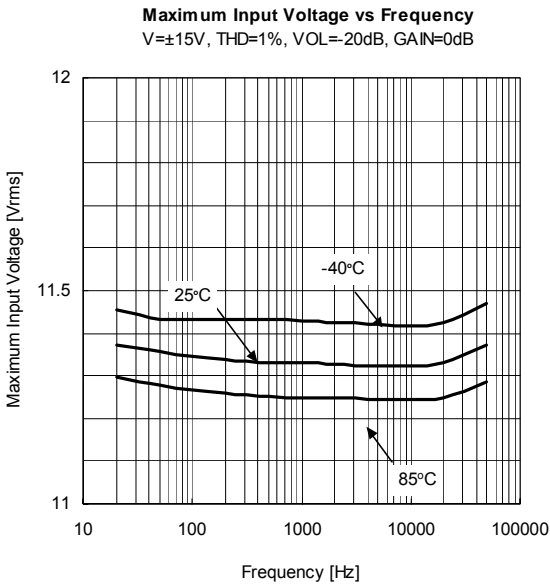
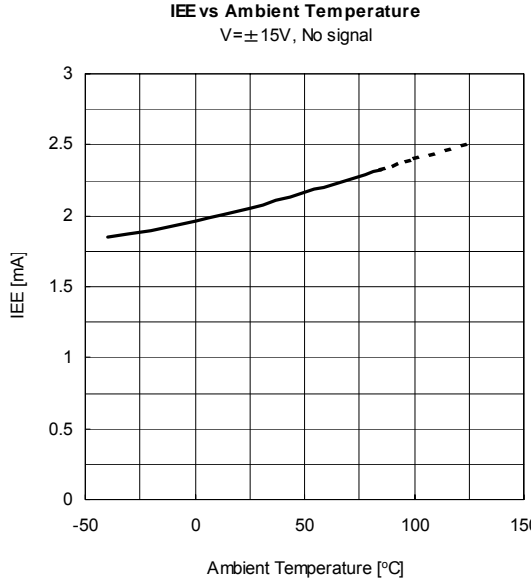
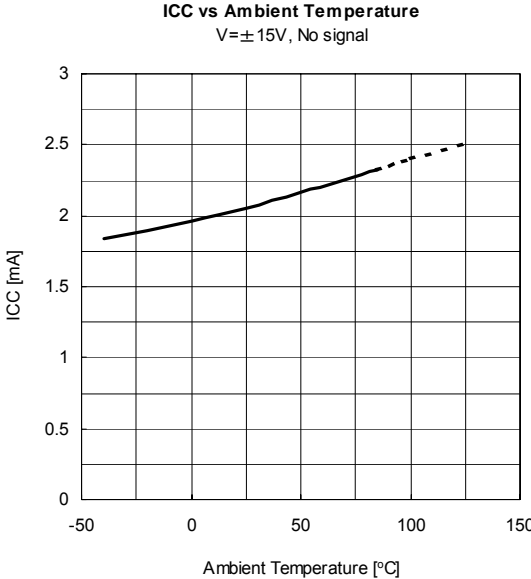
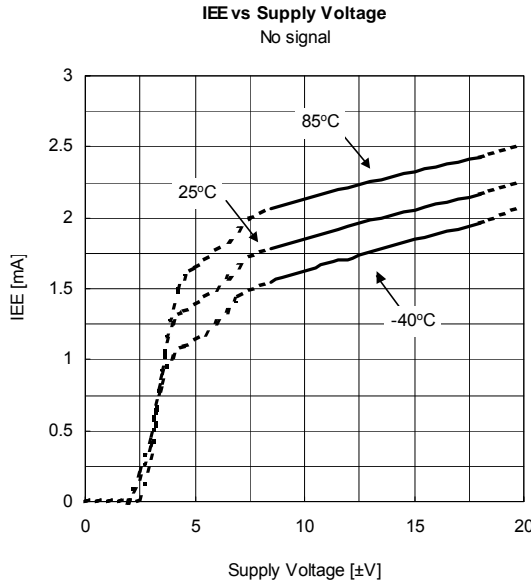
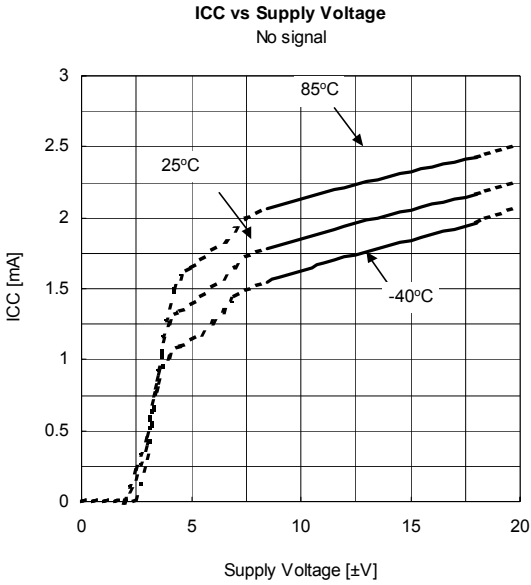

**Volume Gain Output vs Volume Setting**

V=±15V, f=1kHz, Vin=4Vrms, GAIN=0dB, Bandpass

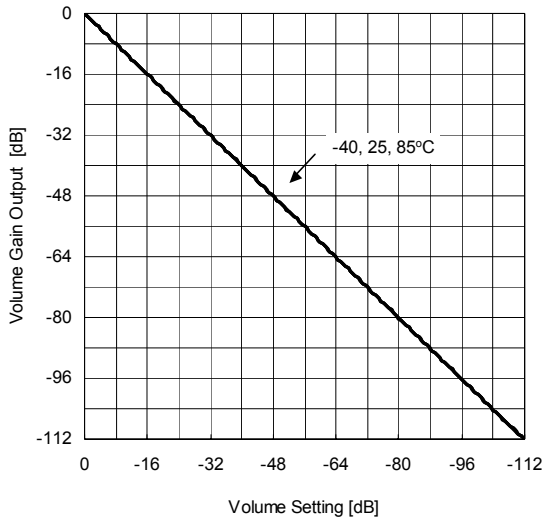

**Volume Gain Output vs Frequency**

V=±15V, f=1kHz, Vin=4Vrms, GAIN=0dB, Bandpass

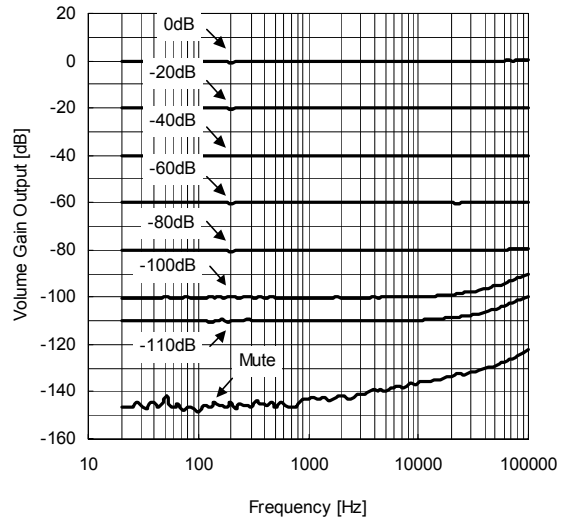

**Volume Gain Output Error vs Volume Setting**

V=±15V, f=1kHz, Vin=4Vrms, GAIN=0dB, Bandpass

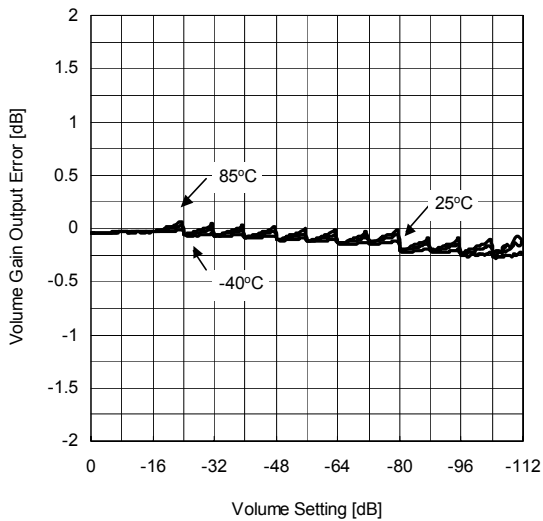

**Volume Gain Output Error vs Volume Setting**

V=±15V, f=1kHz, Vin=100mVrms, VOL=0dB, Bandpass

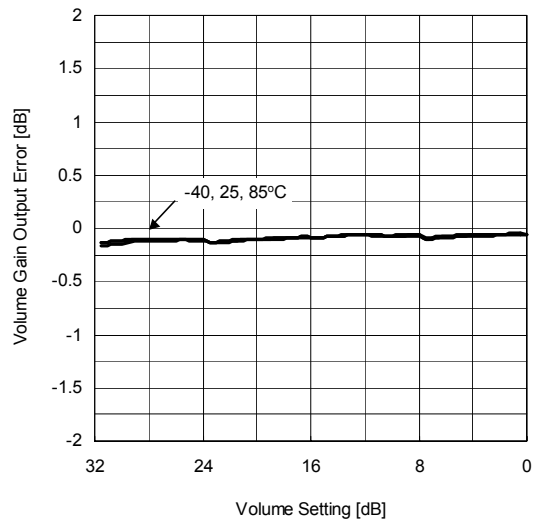

**Volume Resolution vs Volume Setting**

V=±15V, f=1kHz, Vin=4Vrms, GAIN=0dB, Bandpass

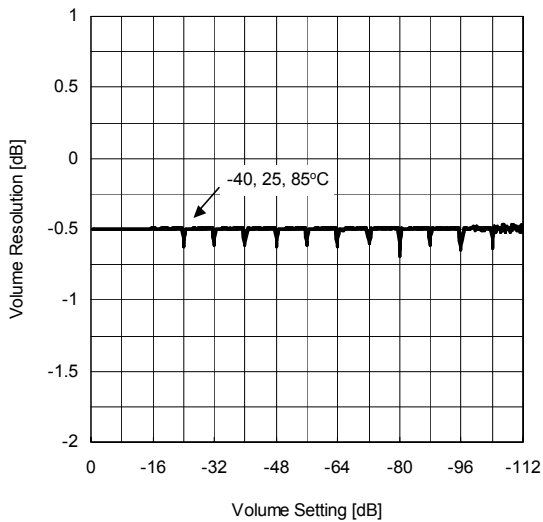

**Volume Resolution vs Volume Setting**

V=±15V, f=1kHz, Vin=100mVrms, VOL=0dB, Bandpass

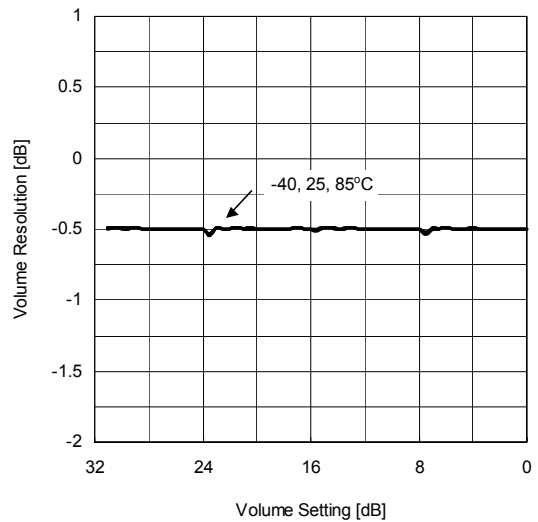



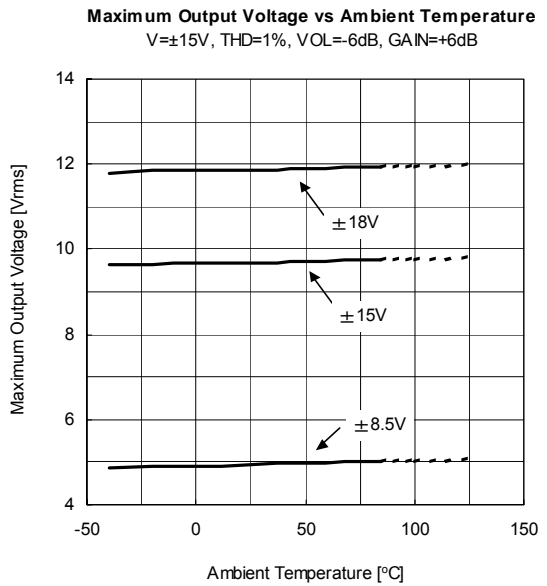
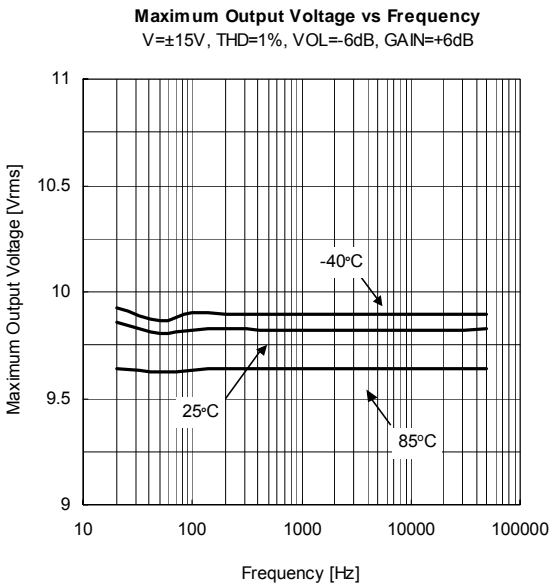
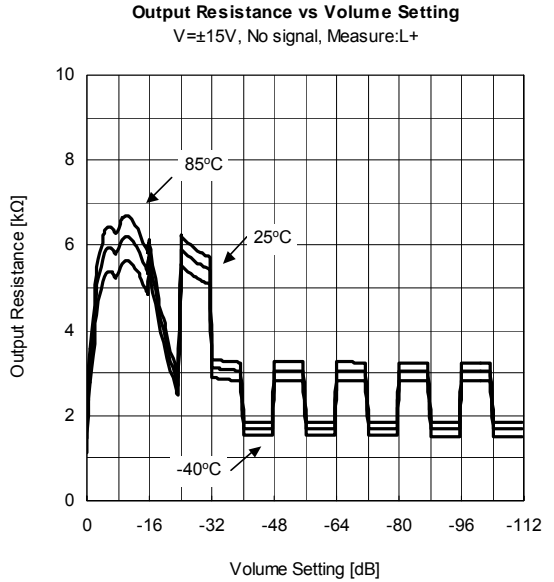
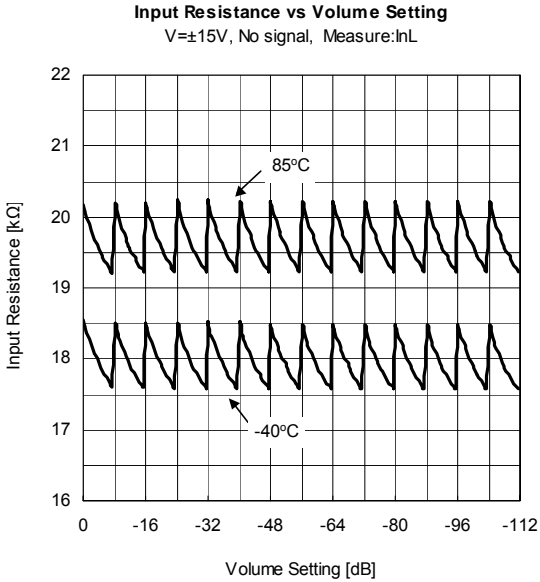
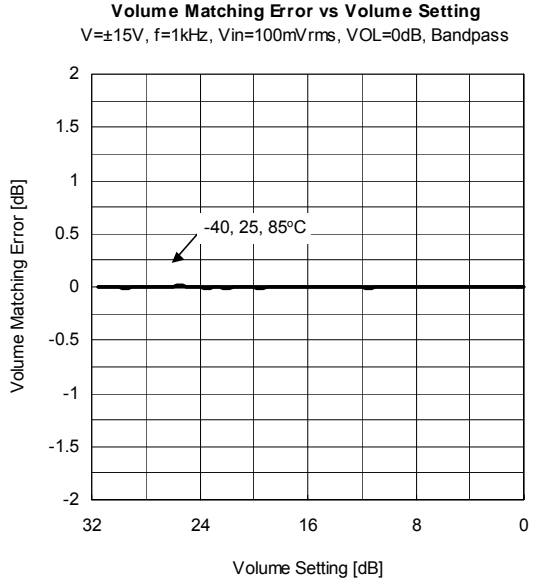
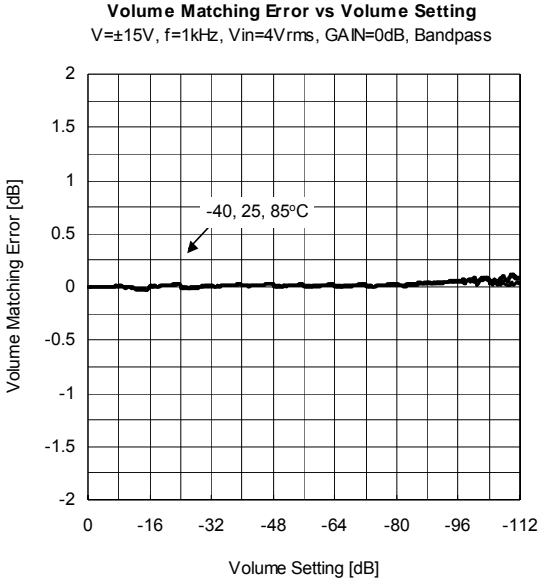

**[CAUTION]**

The specifications on this databook are only given for information, without any guarantee as regards either mistakes or omissions. The application circuits in this databook are described only to show representative usages of the product and not intended for the guarantee or permission of any right including the industrial rights.



Компания «ЭлектроПласт» предлагает заключение долгосрочных отношений при поставках импортных электронных компонентов на взаимовыгодных условиях!

Наши преимущества:

- Оперативные поставки широкого спектра электронных компонентов отечественного и импортного производства напрямую от производителей и с крупнейших мировых складов;
- Поставка более 17-ти миллионов наименований электронных компонентов;
- Поставка сложных, дефицитных, либо снятых с производства позиций;
- Оперативные сроки поставки под заказ (от 5 рабочих дней);
- Экспресс доставка в любую точку России;
- Техническая поддержка проекта, помощь в подборе аналогов, поставка прототипов;
- Система менеджмента качества сертифицирована по Международному стандарту ISO 9001;
- Лицензия ФСБ на осуществление работ с использованием сведений, составляющих государственную тайну;
- Поставка специализированных компонентов (Xilinx, Altera, Analog Devices, Intersil, Interpoint, Microsemi, Aeroflex, Peregrine, Syfer, Eurofarad, Texas Instrument, Miteq, Cobham, E2V, MA-COM, Hittite, Mini-Circuits, General Dynamics и др.);

Помимо этого, одним из направлений компании «ЭлектроПласт» является направление «Источники питания». Мы предлагаем Вам помощь Конструкторского отдела:

- Подбор оптимального решения, техническое обоснование при выборе компонента;
- Подбор аналогов;
- Консультации по применению компонента;
- Поставка образцов и прототипов;
- Техническая поддержка проекта;
- Защита от снятия компонента с производства.



#### Как с нами связаться

**Телефон:** 8 (812) 309 58 32 (многоканальный)

**Факс:** 8 (812) 320-02-42

**Электронная почта:** [org@eplast1.ru](mailto:org@eplast1.ru)

**Адрес:** 198099, г. Санкт-Петербург, ул. Калинина, дом 2, корпус 4, литера А.