



SANYO Semiconductors

DATA SHEET

An ON Semiconductor Company

LV8711T — Bi-CMOS LSI PWM Constant-Current Control Stepping Motor Driver

Overview

The LV8711T is a PWM constant-current control stepping motor driver.

Features

- Two circuits of PWM constant-current control H-bridge drivers incorporated
- Control of the stepping motor to 1-2 phase excitations possible
- Reference voltage output: 1.0V
- Short circuit protection circuit incorporated
- Abnormal condition warning output pin incorporated
- Upper and lower regenerative diodes incorporated
- Thermal shutdown circuit incorporated

Specifications

Absolute Maximum Ratings at Ta = 25°C

Parameter	Symbol	Conditions	Ratings	Unit
Motor supply voltage	VM max		18	V
Logic supply voltage	V _{CC} max		6	V
Logic input voltage	V _{IN}		6	V
Output peak current	I _O peak	Per ch, tw ≤ 10ms, duty 20%	1.0	A
Output continuous current	I _O max	Per ch	800	mA
Allowable power dissipation	Pd max	*	1.45	W
Operating temperature	T _{opr}		-20 to +85	°C
Storage temperature	T _{stg}		-55 to +150	°C

* Specified circuit board : 57.0mm×57.0mm×1.7mm, glass epoxy printed circuit board.

■ Any and all SANYO Semiconductor Co.,Ltd. products described or contained herein are, with regard to "standard application", intended for the use as general electronics equipment (home appliances, AV equipment, communication device, office equipment, industrial equipment etc.). The products mentioned herein shall not be intended for use for any "special application" (medical equipment whose purpose is to sustain life, aerospace instrument, nuclear control device, burning appliances, transportation machine, traffic signal system, safety equipment etc.) that shall require extremely high level of reliability and can directly threaten human lives in case of failure or malfunction of the product or may cause harm to human bodies, nor shall they grant any guarantee thereof. If you should intend to use our products for applications outside the standard applications of our customer who is considering such use and/or outside the scope of our intended standard applications, please consult with us prior to the intended use. If there is no consultation or inquiry before the intended use, our customer shall be solely responsible for the use.

■ Specifications of any and all SANYO Semiconductor Co.,Ltd. products described or contained herein stipulate the performance, characteristics, and functions of the described products in the independent state, and are not guarantees of the performance, characteristics, and functions of the described products as mounted in the customer's products or equipment. To verify symptoms and states that cannot be evaluated in an independent device, the customer should always evaluate and test devices mounted in the customer's products or equipment.

LV8711T

Recommended Operating Ratings at Ta = 25°C

Parameter	Symbol	Conditions	Ratings	Unit
Motor supply voltage range	VM		4 to 16	V
Logic supply voltage range	V _{CC}		2.7 to 5.5	V
Logic input voltage range	V _{IN}		-0.3 to V _{CC} +0.3	V
VREF input voltage range	VREF		0 to V _{CC} -1.8	V

Electrical Characteristics at Ta = 25°C, VM = 12V, V_{CC} = 3.3, VREF = 1.0V

Parameter	Symbol	Conditions	Ratings			Unit
			min	typ	max	
General						
Standby mode current drain	IMstn	PS = "L", no load			1	μA
	I _{CC} stn	PS = "L", no load			1	μA
Current drain	IM	PS = "H", no load		1.0	1.5	mA
	I _{CC}	PS = "H", no load		1.7	3.0	mA
Thermal shutdown temperature	TSD	Design guarantee	150	180		°C
Thermal hysteresis width	ΔTSD	Design guarantee		40		°C
V _{CC} low voltage cutting voltage	V _{th} V _{CC}		2.1	2.4	2.7	V
Low voltage hysteresis voltage	V _{th} HYS		100	130	160	mV
Reference voltage						
REG5 output voltage	VREG5		4.5	5	5.5	V
Output						
Output on resistance	R _{on} U	I _O = -800mA, Source-side		0.78	1.0	Ω
	R _{on} D	I _O = 800mA, Sink-side		0.32	0.43	Ω
Output leakage current	I _O leak	V _O = 15V			10	μA
Diode forward voltage	VD	ID = -800mA		1.0	1.2	V
Logic input						
Logic pin input current	I _{IN} L	V _{IN} = 0.8V	4	8	12	μA
	I _{IN} H	V _{IN} = 3.3V	22	33	45	μA
Logic high-level input voltage	V _{INH}		2.0			V
Logic low-level input voltage	V _{INL}				0.8	V
Constant-current control						
REG1 output voltage	VREG1		0.95	1.0	1.05	V
VREF input current	I _{REF}	VREF = 1.0V	-0.5			μA
Current setting reference voltage	V _{tatt} 00	VREF = 1.0V	0.192	0.200	0.208	V
	V _{tatt} 01	VREF = 1.0V	0.152	0.160	0.168	V
	V _{tatt} 10	VREF = 1.0V	0.092	0.100	0.108	V
	V _{tatt} 11	VREF = 1.0V	0.032	0.040	0.048	V
Chopping frequency	F _{chop}	C _{chop} = 220pF	36	45	54	kHz
CHOP pin threshold voltage	V _{CHOP} H		0.6	0.7	0.8	V
	V _{CHOP} L		0.17	0.2	0.23	V
CHOP pin charge/discharge current	I _{chop}		7	10	13	μA
Output short-circuit protection						
EMO pin saturation voltage	V _{sat} EMO	I _{EMO} = 1mA		250	400	mV

LV8711T

Package Dimensions

unit : mm (typ)

3260A

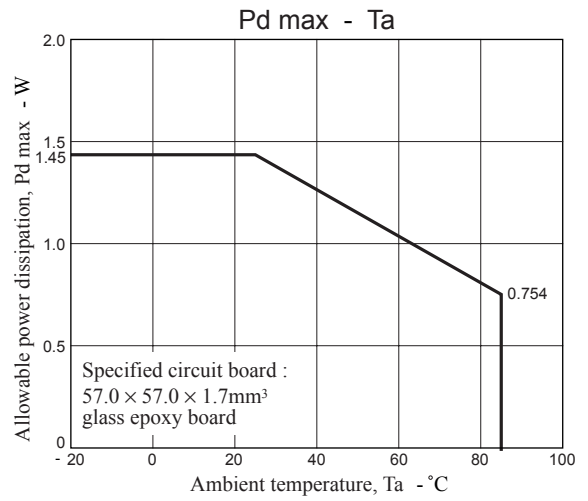
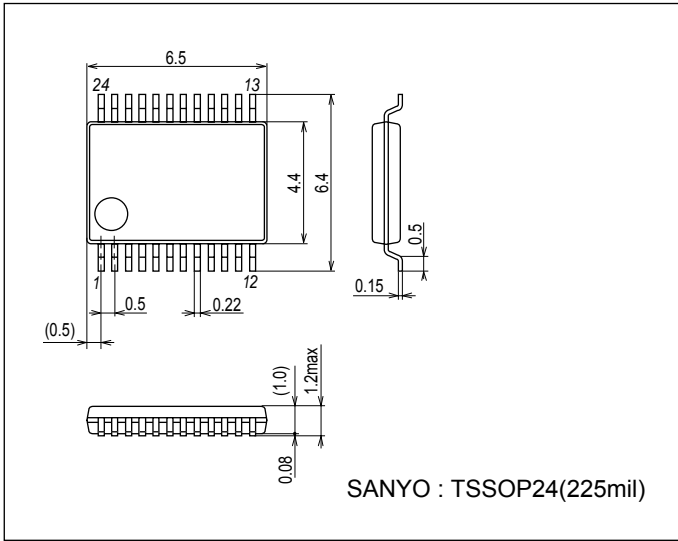

Pin Assignment

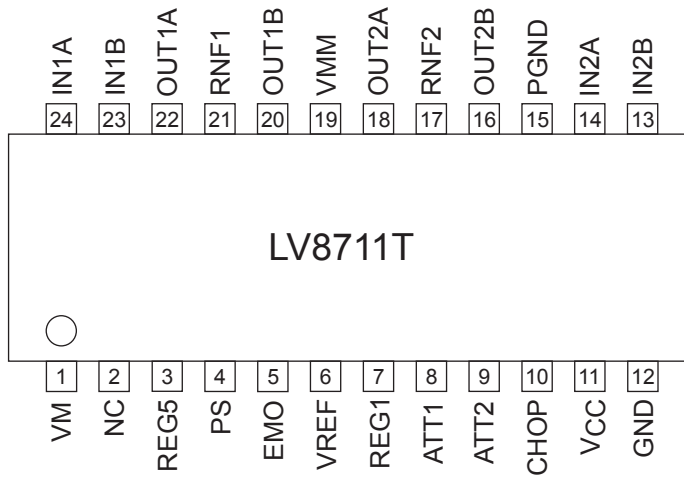

Block Diagram

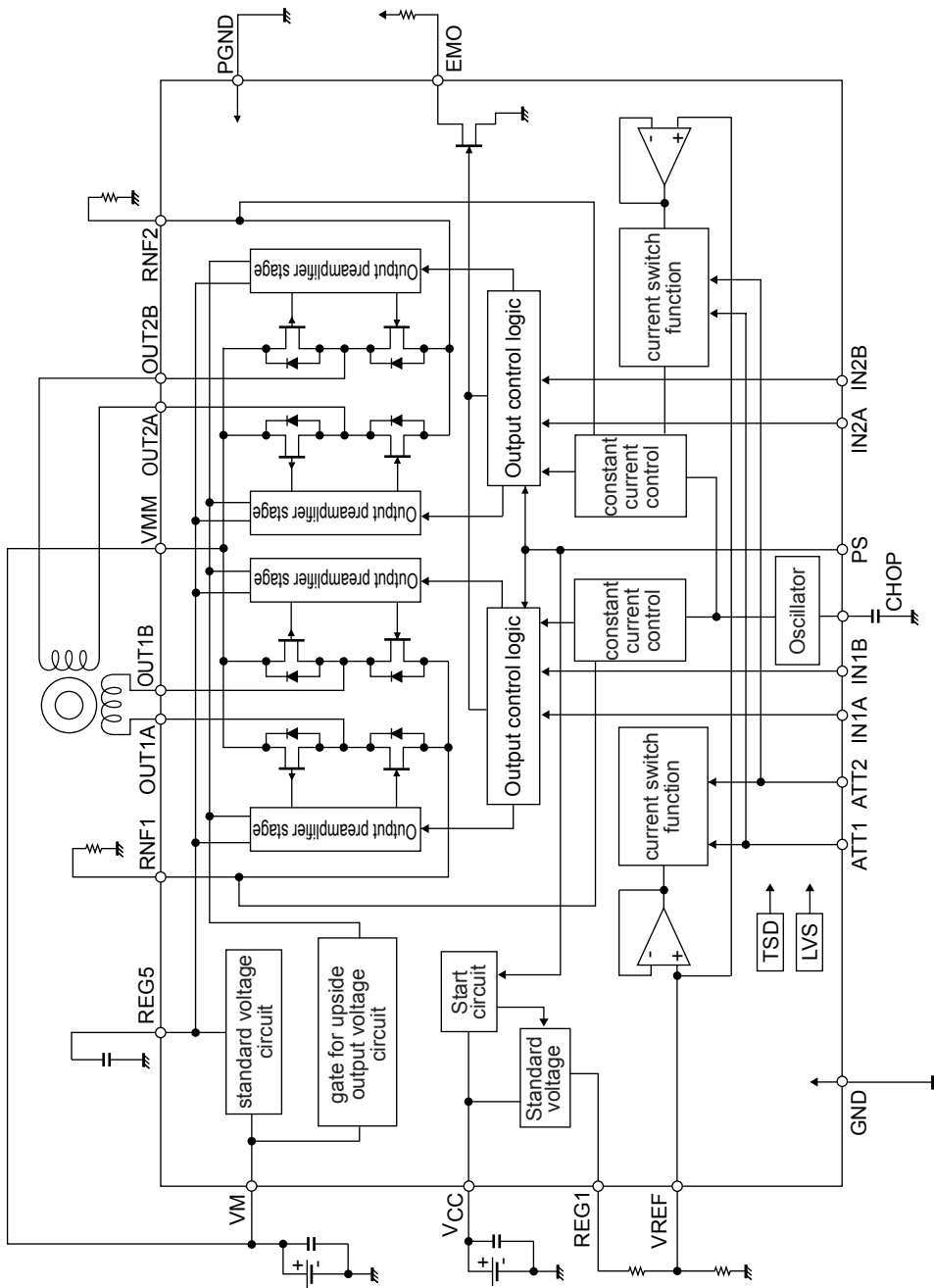

LV8711T

Pin Functions

Pin No.	Pin Name	Pin Function	Equivalent Circuit
8 9 13 14 23 24	ATT1 ATT2 IN2B IN2A IN1B IN1A	Energization current switching pin 1. Energization current switching pin 2. Channel 2 driver output control input pin. Channel 2 driver output control input pin. Channel 1 driver output control input pin. Channel 1 driver output control input pin.	
4	PS	Enable input pin.	
16 17 18 20 21 22	OUT2B RNF2 OUT2A OUT1B RNF1 OUT1A	Channel 2 OUTB output pin. Channel 2 current sensing resistor connection pin. Channel 2 OUTA output pin. Channel 1 OUTB output pin. Channel 1 current sensing resistor connection pin. Channel 1 OUTA output pin.	
3	REG5	Internal reference voltage output pin.	

Continued on next page.

LV8711T

Continued from preceding page.

Pin No.	Pin Name	Pin Function	Equivalent Circuit
5	EMO	Abnormal condition warning output pin.	
6	VREF	Channel 1 and 2 current setting reference voltage input pin.	
7	REG1	Current setting reference voltage output pin.	
10	CHOP	Chopping frequency setting capacitor connection pin.	

(5) Constant-current control time chart (chopping operate)

In each current mode, the operation sequence is as described below:

- At first of chopping cycle, the IC goes to CHARGE mode. (The Blanking section in which the CHARGE mode is forced regardless of the magnitudes of the coil current (I_{COIL}) and the set current (I_{REF}) exists for $1\mu s$.)
- In Blanking section, the IC compares the coil current (I_{COIL}) and the set current (I_{REF}).
If the $I_{COIL} < I_{REF}$ state is existent in Blanking section.

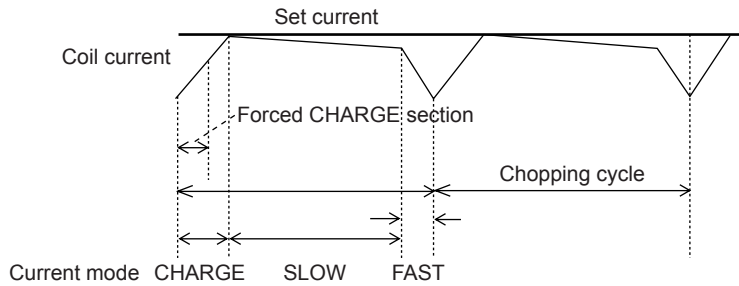

Charge mode continues until $I_{COIL} \geq I_{REF}$. After that the IC switches to SLOW DECAY mode and then switches to FAST DECAY mode for the last about $1\mu s$.

If the $I_{COIL} < I_{REF}$ state is non-existent in Blanking section.

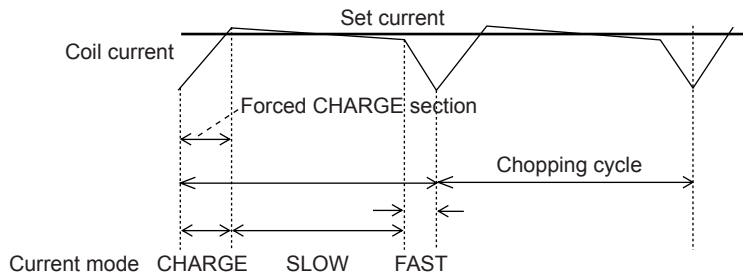

The IC switches to SLOW DECAY after Blanking section, and then switches to FAST DECAY mode for the last about $1\mu s$.

The IC repeats the above operation.

LV8711T

(6) Typical current waveform in each excitation mode

6-1) STM Drive mode

Two-phase excitation (CW mode)

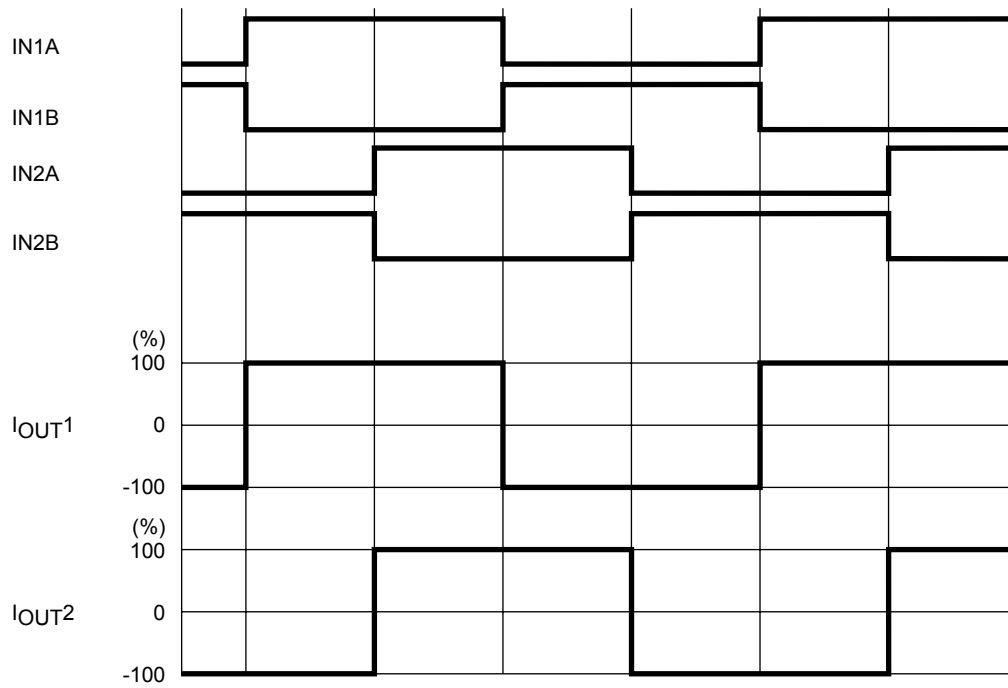

1-2 phase excitation (CW mode)

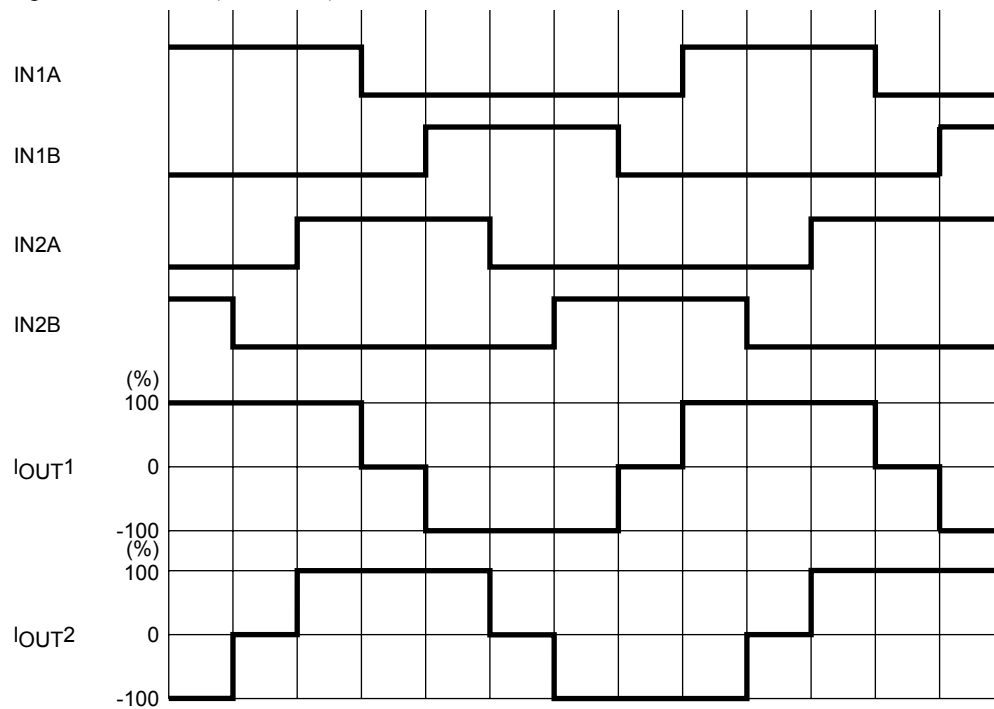

6-2) DCM Drive mode

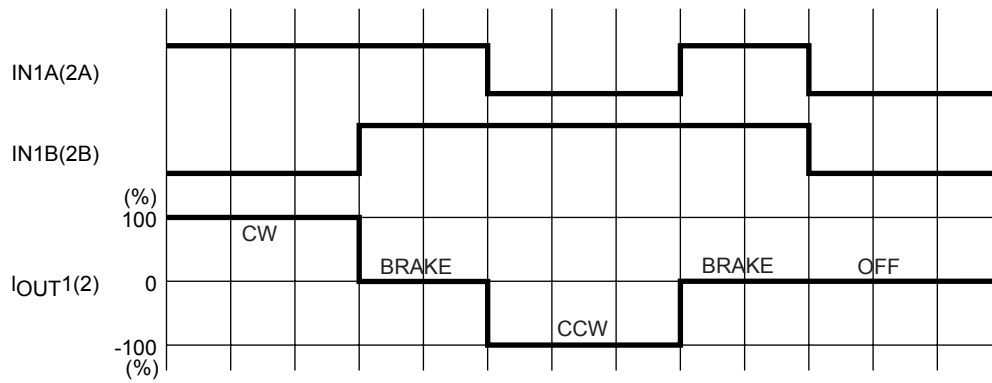

(7) Output short-circuit protection

To protect IC from damage due to short-circuit of the output caused by lightning or ground fault, the output short-circuit protection circuit to put the output in the OFF mode is incorporated.

7-1) Protective function operation (Latch method)

When detecting the output short-circuit state, the short-circuit protection circuit is activated.

When short-circuit state is detected $\approx 4\mu\text{s}$ (count by the internal timer), detected output is OFF at the time.

Then, when the output exceeds the timer latch time counted by the internal counter, the output is ON. Still, the short circuit state is detected, the IC switches all output to stand-by mode and keep the state.

This state is released by setting PS = Low

(8) Abnormal condition warning output pin

EMO, warning output pin of thermal shutdown circuit and the output short-circuit protection circuit, is an open-drain output. EMO outputs ON when output short-circuit is detected.

When detecting the output overdrive, the EMO outputs ON. If the junction temperature goes down at the time, EMO outputs OFF automatically.

(9) Recommended power-on sequence

Provide a wait time of $10\mu\text{s}$ or more after V_{CC} power supply rises before supplying VM power supply.

Provide a wait time of $10\mu\text{s}$ or more after VM power supply rises before setting the PS pin High.

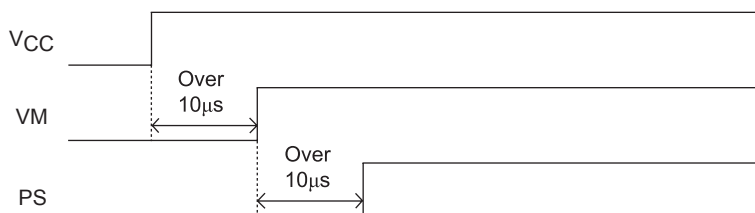

The above power-on sequence is only a recommendation, and there are no risks of damage or over current to the IC even if this sequence is not followed.

Application Circuit Example

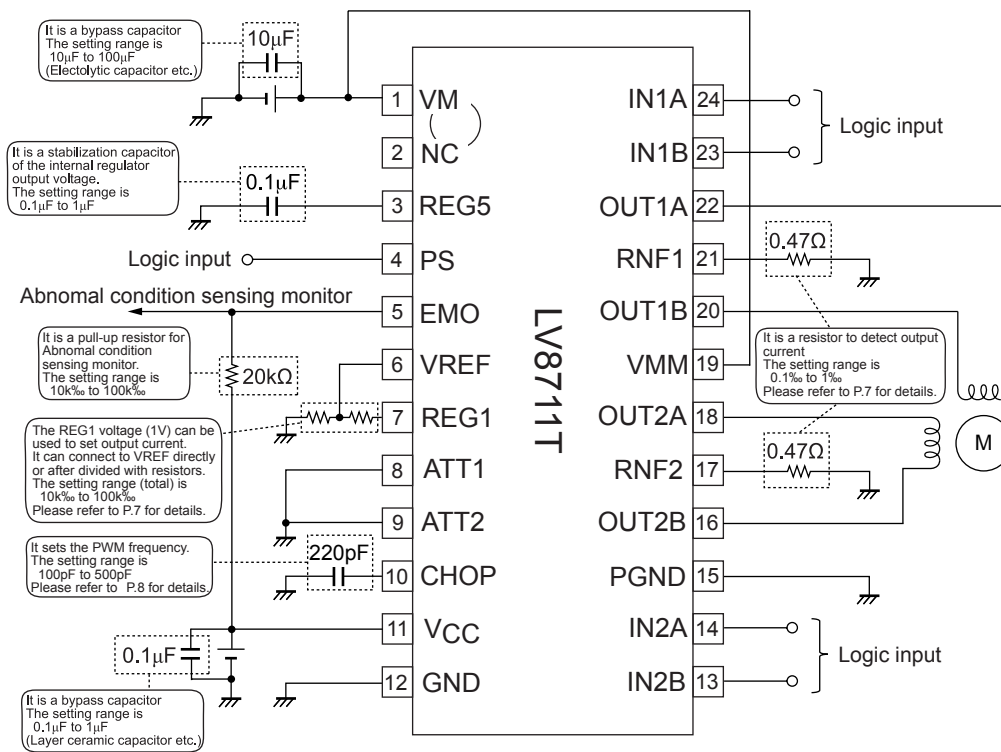

Each constant setting method for the above circuit diagram example is as follows :

Current LIMIT (100%) set

$$VREF = 1.0V \text{ (when internal regulator output is connected)}$$

$$I_{LIMIT} = VREF / 5 / RNF \text{ resistance}$$

$$= 1.0V / 5 / 0.47\Omega = 425mA$$

Chopping frequency setting

$$F_{chop} = I_{chop} / (C_{chop} \times V_t \times 2)$$

$$= 10\mu A / (220pF \times 0.5V \times 2) = 45 \text{ kHz}$$

- SANYO Semiconductor Co.,Ltd. assumes no responsibility for equipment failures that result from using products at values that exceed, even momentarily, rated values (such as maximum ratings, operating condition ranges, or other parameters) listed in products specifications of any and all SANYO Semiconductor Co.,Ltd. products described or contained herein.
- SANYO Semiconductor Co.,Ltd. strives to supply high-quality high-reliability products, however, any and all semiconductor products fail or malfunction with some probability. It is possible that these probabilistic failures or malfunction could give rise to accidents or events that could endanger human lives, trouble that could give rise to smoke or fire, or accidents that could cause damage to other property. When designing equipment, adopt safety measures so that these kinds of accidents or events cannot occur. Such measures include but are not limited to protective circuits and error prevention circuits for safe design, redundant design, and structural design.
- In the event that any or all SANYO Semiconductor Co.,Ltd. products described or contained herein are controlled under any of applicable local export control laws and regulations, such products may require the export license from the authorities concerned in accordance with the above law.
- No part of this publication may be reproduced or transmitted in any form or by any means, electronic or mechanical, including photocopying and recording, or any information storage or retrieval system, or otherwise, without the prior written consent of SANYO Semiconductor Co.,Ltd.
- Any and all information described or contained herein are subject to change without notice due to product/technology improvement, etc. When designing equipment, refer to the "Delivery Specification" for the SANYO Semiconductor Co.,Ltd. product that you intend to use.
- Information (including circuit diagrams and circuit parameters) herein is for example only; it is not guaranteed for volume production.
- Upon using the technical information or products described herein, neither warranty nor license shall be granted with regard to intellectual property rights or any other rights of SANYO Semiconductor Co.,Ltd. or any third party. SANYO Semiconductor Co.,Ltd. shall not be liable for any claim or suits with regard to a third party's intellectual property rights which has resulted from the use of the technical information and products mentioned above.

This catalog provides information as of March, 2010. Specifications and information herein are subject to change without notice.



Компания «ЭлектроПласт» предлагает заключение долгосрочных отношений при поставках импортных электронных компонентов на взаимовыгодных условиях!

Наши преимущества:

- Оперативные поставки широкого спектра электронных компонентов отечественного и импортного производства напрямую от производителей и с крупнейших мировых складов;
- Поставка более 17-ти миллионов наименований электронных компонентов;
- Поставка сложных, дефицитных, либо снятых с производства позиций;
- Оперативные сроки поставки под заказ (от 5 рабочих дней);
- Экспресс доставка в любую точку России;
- Техническая поддержка проекта, помощь в подборе аналогов, поставка прототипов;
- Система менеджмента качества сертифицирована по Международному стандарту ISO 9001;
- Лицензия ФСБ на осуществление работ с использованием сведений, составляющих государственную тайну;
- Поставка специализированных компонентов (Xilinx, Altera, Analog Devices, Intersil, Interpoint, Microsemi, Aeroflex, Peregrine, Syfer, Eurofarad, Texas Instrument, Miteq, Cobham, E2V, MA-COM, Hittite, Mini-Circuits, General Dynamics и др.);

Помимо этого, одним из направлений компании «ЭлектроПласт» является направление «Источники питания». Мы предлагаем Вам помощь Конструкторского отдела:

- Подбор оптимального решения, техническое обоснование при выборе компонента;
- Подбор аналогов;
- Консультации по применению компонента;
- Поставка образцов и прототипов;
- Техническая поддержка проекта;
- Защита от снятия компонента с производства.



Как с нами связаться

Телефон: 8 (812) 309 58 32 (многоканальный)

Факс: 8 (812) 320-02-42

Электронная почта: org@eplast1.ru

Адрес: 198099, г. Санкт-Петербург, ул. Калинина, дом 2, корпус 4, литера А.