

| REVISIONS | | | | | |
|-----------|-----|----------------------|-----------|-------|-------|
| REV | ECO | DESCRIPTION | DATE | BY | APPR |
| A1 | - | RELEASE | 2JUL2018 | JAH | |
| A2 | - | UPDATE DRAWING | 18/MAR/19 | BROOK | TOMMY |
| A3 | - | MODIFIED DESCRIPTION | 12JUL19 | BROOK | TOMMY |

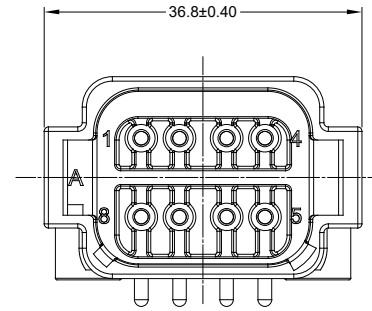
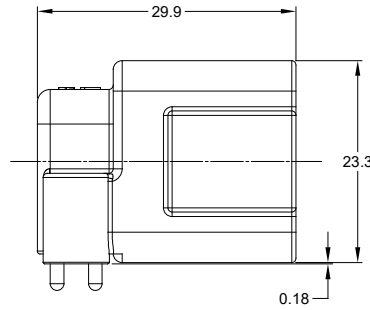
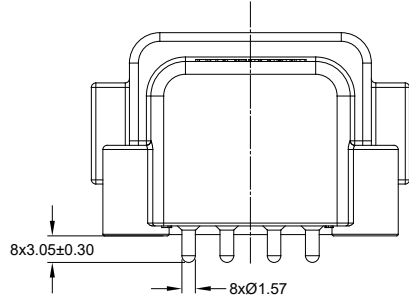
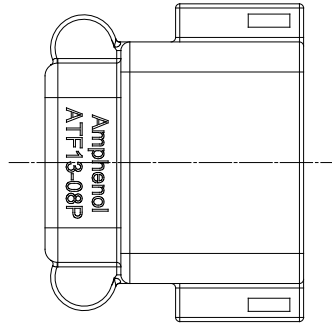
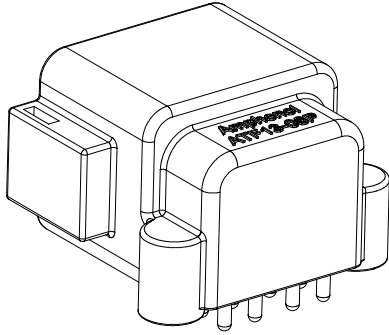

NOTES: UNLESS OTHERWISE SPECIFIED

1 SEE SHEET 2 FOR KEY ARRANGEMENTS AND COLORS.

2. MATERIAL:
 HOUSING: THERMOPLASTIC; COLOR: SEE SHEET 2
 CONTACT: COPPER ALLOY
 PLATING: NICKEL UNDERPLATE
 SEE CHART FOR OVERALL FINISH

3. MODIFICATIONS: RIGHT ANGLE PCB MOUNT, SCREW BOSS

4. SPECIFICATIONS:
 4.1 CURRENT RATING: 13 AMPS
 4.2 OPERATING TEMPERATURE: -55°C TO +125°C
 4.3 DIELECTRIC WITHSTANDING VOLTAGE: LESS THAN 2 MILLIAMPS CURRENT LEAKAGE @ 1500 VOLTS AC.
 4.4 INSULATION RESISTANCE: 1000 MEGOHMS MIN @ 25°C.
 4.5 MOISTURE RESISTANCE: IP67 (MATED CONDITION)
 4.6 MATING CYCLE DURABILITY: 100 CYCLES
 4.7 RoHS COMPLIANT

5. MATING PART: AT06-08SX* PLUG
 (X = A,B,C,D KEYS; * = MODIFICATIONS AND COLORS)

6. ALL DIMENSIONS ARE FOR REFERENCE USE ONLY.

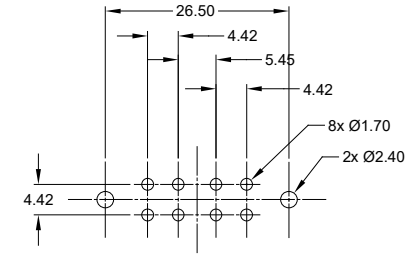
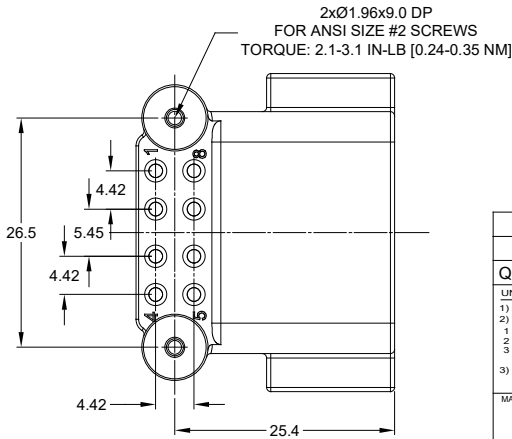

RECOMMENDED PCB LAYOUT

| SEE PART NUMBER CHART | | DESCRIPTION | | ITEM |
|--|----------------|---------------------|----------|-----------|
| PART NUMBER | | DESCRIPTION | | ITEM |
| QUANTITY | MATERIALS LIST | | | |
| UNLESS OTHERWISE SPECIFIED | | | | |
| 1) All dimensions are in metric (mm). | | | | |
| 2) Tolerances are as follows: | | | | |
| 1 PL DEC ±0.30 Fractions ±1/64 | | | | |
| 2 PL DEC ±0.15 Angles ±1° | | | | |
| 3 PL DEC ±0.08 | | | | |
| 3) Note reference = | | | | |
| MATERIAL SPECIFICATIONS: | | SIGNATURES | | DATE |
| PROCESS SPECIFICATIONS: | | DRAWN: BROOKDING | | 12/JUL/19 |
| NEXT ASSY: | | CHECKED: ORIONLI | | 12/JUL/19 |
| | | ENGINEER: | | |
| | | APPROVAL: TOMMY.XIE | | 12/JUL/19 |
| | | CUSTOMER: | | |
| THIS DRAWING IS SUPPLIED FOR INFORMATION ONLY. DESIGN FEATURES, SPECIFICATIONS AND PERFORMANCE DATA SHOWN HEREON ARE THE PROPERTY OF THE AMPHENOL CORPORATION. NO RIGHTS OF REPRODUCTION ARE IMPLIED. ALL DIMENSIONS ARE SUBJECT TO NORMAL MANUFACTURING VARIATIONS. | | | | |
| SIZE | TYPE | DWG NO. | REVISION | |
| B | C- | ATF13-8PX-BM1X | A3 | |
| SCALE | NONE | SHEET 1 OF 2 | | |

TITLE: RIGHT ANGLE RECEPT. AT 8 PIN, SCREW BOSS, BOARDLOCK
 DWG NO.: ATF13-8PX-BM1X
 REV: A3
 SH: 1
 OF: 2

| REVISIONS | | | | | |
|-----------|-----|----------------------|-----------|-------|-------|
| REV | ECO | DESCRIPTION | DATE | BY | APPR |
| A1 | - | RELEASE | 2JUL2018 | JAH | |
| A2 | - | UPDATE DRAWING | 18/MAR/19 | BROOK | TOMMY |
| A3 | - | MODIFIED DESCRIPTION | 12JUL19 | BROOK | TOMMY |

P/N ATF13-08PA-BM1X
KEY-A CONFIGURATION
COLOR: GREY

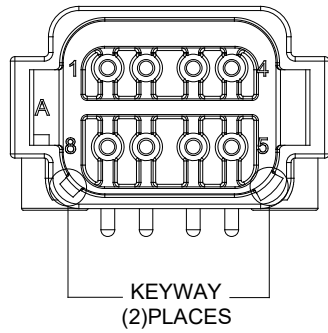

P/N ATF13-08PB-BM1X
KEY-B CONFIGURATION
COLOR: BLACK

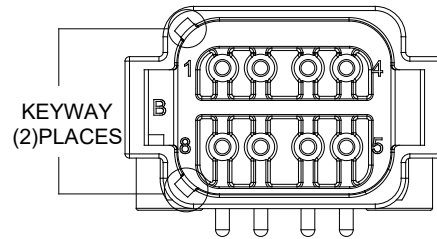

P/N ATF13-08PC-BM1X
KEY-C CONFIGURATION
COLOR: GREEN

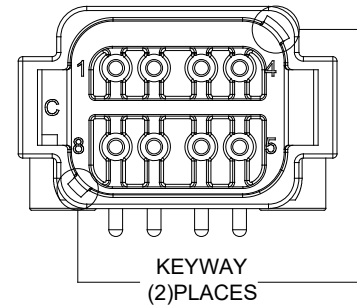

P/N ATF13-08PD-BM1X
KEY-D CONFIGURATION
COLOR: BROWN

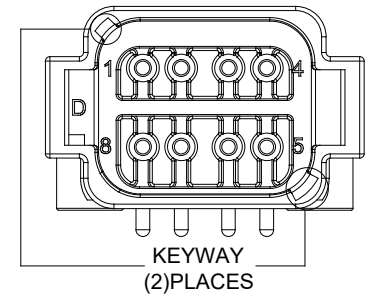

| ATF13-08PA-BM1X VARIANTS | |
|--------------------------|-----------------|
| CONTACT PLATING | PART NUMBER |
| GOLD | ATF13-08PA-BM11 |
| TIN | ATF13-08PA-BM13 |

| ATF13-08PB-BM1X VARIANTS | |
|--------------------------|-----------------|
| CONTACT PLATING | PART NUMBER |
| GOLD | ATF13-08PB-BM11 |
| TIN | ATF13-08PB-BM13 |

| ATF13-08PC-BM1X VARIANTS | |
|--------------------------|-----------------|
| CONTACT PLATING | PART NUMBER |
| GOLD | ATF13-08PC-BM11 |
| TIN | ATF13-08PC-BM13 |

| ATF13-08PD-BM1X VARIANTS | |
|--------------------------|-----------------|
| CONTACT PLATING | PART NUMBER |
| GOLD | ATF13-08PD-BM11 |
| TIN | ATF13-08PD-BM13 |

| | | | | | | |
|--|--|-------------------|--|--|--|--|
| SEE PART NUMBER CHART | | PART NUMBER | | DESCRIPTION | | ITEM |
| QUANTITY | | MATERIALS LIST | | | | |
| UNLESS OTHERWISE SPECIFIED: 1) All dimensions are in metric (mm). 2) Tolerances are as follows: 1 PL DEC ±0.30 Fractions ±1/64 2 PL DEC ±0.15 Angles ±1° 3 PL DEC ±0.08 | | SIGNATURES | | DATE | | <p style="text-align: center;">Amphenol</p> <p style="text-align: center;">Sine Systems - www.amphenol-sine.com 44724 Morley Drive Clinton Township, MI 48036</p> <p style="text-align: center;">RIGHT ANGLE RECEPTACLE, AT 8 PIN, SCREW BOSS, BOARDLOCK</p> |
| 3) Note reference = | | DRAWN: BROOK.DING | | 12/JUL/19 | | |
| MATERIAL SPECIFICATIONS: | | CHECKED: ORION.LI | | 12/JUL/19 | | |
| PROCESS SPECIFICATIONS: | | ENGINEER: | | APPROVAL: TOMMY.XIE | | |
| NEXT ASSY: | | CUSTOMER: | | THIS DRAWING IS SUPPLIED FOR INFORMATION ONLY. DESIGN FEATURES, SPECIFICATIONS AND PERFORMANCE DATA SHOWN HEREON ARE THE PROPERTY OF THE AMPHENOL CORPORATION. NO RIGHTS OF REPRODUCTION ARE IMPLIED. ALL DIMENSIONS ARE SUBJECT TO NORMAL MANUFACTURING VARIATIONS. | | REVISION |
| | | SCALE: NONE | | SIZE: B C- TYPE: C- DWG NO: ATF13-8PX-BM1X | | A3 |
| | | | | SHEET 2 OF 2 | | |

TITLE: RIGHT ANGLE RECEPT. AT 8 PIN, SCREW BOSS, BOARDLOCK
DWG NO: ATF13-8PX-BM1X
REV: A3
SH: 2
OF: 2



Компания «ЭлектроПласт» предлагает заключение долгосрочных отношений при поставках импортных электронных компонентов на взаимовыгодных условиях!

Наши преимущества:

- Оперативные поставки широкого спектра электронных компонентов отечественного и импортного производства напрямую от производителей и с крупнейших мировых складов;
- Поставка более 17-ти миллионов наименований электронных компонентов;
- Поставка сложных, дефицитных, либо снятых с производства позиций;
- Оперативные сроки поставки под заказ (от 5 рабочих дней);
- Экспресс доставка в любую точку России;
- Техническая поддержка проекта, помощь в подборе аналогов, поставка прототипов;
- Система менеджмента качества сертифицирована по Международному стандарту ISO 9001;
- Лицензия ФСБ на осуществление работ с использованием сведений, составляющих государственную тайну;
- Поставка специализированных компонентов (Xilinx, Altera, Analog Devices, Intersil, Interpoint, Microsemi, Aeroflex, Peregrine, Syfer, Eurofarad, Texas Instrument, Miteq, Cobham, E2V, MA-COM, Hittite, Mini-Circuits, General Dynamics и др.);

Помимо этого, одним из направлений компании «ЭлектроПласт» является направление «Источники питания». Мы предлагаем Вам помощь Конструкторского отдела:

- Подбор оптимального решения, техническое обоснование при выборе компонента;
- Подбор аналогов;
- Консультации по применению компонента;
- Поставка образцов и прототипов;
- Техническая поддержка проекта;
- Защита от снятия компонента с производства.



Как с нами связаться

Телефон: 8 (812) 309 58 32 (многоканальный)

Факс: 8 (812) 320-02-42

Электронная почта: org@eplast1.ru

Адрес: 198099, г. Санкт-Петербург, ул. Калинина, дом 2, корпус 4, литера А.