

FEATURES

2.25 V to 5.5 V operating voltage range

Low power consumption (4 μ A)

High voltage (22 V) tolerance on inputs

Output stages

ADCMP370: open-drain, high voltage (22 V tolerance)

ADCMP371: push-pull

50 nA input bias current

150 nA input offset current

9 mV input offset voltage

Rail-to-rail, common-mode input range

Specified over -40°C to $+85^{\circ}\text{C}$ temperature range

5-lead SC70 packaging

APPLICATIONS

Voltage detectors

Battery management systems

Analog-to-digital converters

Low voltage applications

Battery-powered electronics

Portable equipment

GENERAL DESCRIPTION

The ADCMP370/ADCMP371 are general-purpose comparators with input offset voltages of 9 mV (maximum) and low power consumption, which make them ideal for battery-powered, portable equipment.

The ADCMP371 has a push-pull output stage, while the ADCMP370 has an open-drain output. The inputs on both parts and the output on the ADCMP370 can tolerate voltages up to 22 V, making them suitable for use as voltage detectors in portable equipment.

The devices are available in space-efficient, 5-lead SC70 packaging.

FUNCTIONAL BLOCK DIAGRAMS

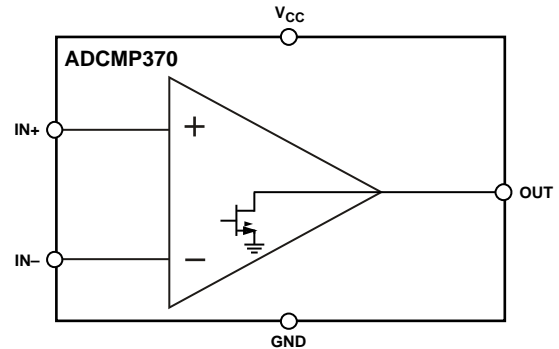

Figure 1.

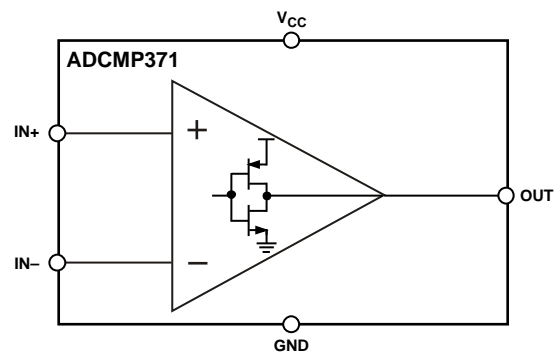

Figure 2.

Rev. B

Information furnished by Analog Devices is believed to be accurate and reliable. However, no responsibility is assumed by Analog Devices for its use, nor for any infringements of patents or other rights of third parties that may result from its use. Specifications subject to change without notice. No license is granted by implication or otherwise under any patent or patent rights of Analog Devices. Trademarks and registered trademarks are the property of their respective owners.

TABLE OF CONTENTS

Features	1	Pin Configuration and Function Descriptions.....	5
Applications.....	1	Typical Performance Characteristics	6
General Description	1	Applications.....	9
Functional Block Diagrams.....	1	Basic Comparator.....	9
Revision History	2	Adding Hysteresis.....	9
Specifications.....	3	Outline Dimensions	11
Absolute Maximum Ratings.....	4	Ordering Guide	11
ESD Caution.....	4		

REVISION HISTORY

3/11—Rev. A to Rev. B

Changes to Figure 19 Caption.....	9
Changes to Adding Hysteresis Section	9
Added Figure 21 and Figure 22, Renumbered Sequentially	10
Updated Outline Dimensions	11

1/06—Rev. 0 to Rev. A

Changes to Features.....	1
Changes to Figure 19.....	9
Changes to Figure 20 Caption.....	10
Updated Outline Dimensions	11

10/04—Revision 0: Initial Version

SPECIFICATIONS

V_{CC} = full operating range, T_A = -40°C to $+85^{\circ}\text{C}$, unless otherwise noted.

Table 1.

Parameter	Min	Typ	Max	Unit	Test Conditions/Comments
SUPPLY					
V_{CC} Operating Voltage Range	2.25		5.5	V	
Supply Current		4	7	μA	
COMMON-MODE INPUT RANGE	0		V_{CC}	V	
INPUT OFFSET VOLTAGE			9	mV	$V_{IN} = V_{CC} / 2$
INPUT OFFSET VOLTAGE AVERAGE DRIFT		5		$\mu\text{V}/^{\circ}\text{C}$	$V_{CM} = 0\text{ V}$
INPUT BIAS CURRENT			50	nA	$V_{IN} = V_{CC} / 2$
INPUT OFFSET CURRENT			150	nA	$V_{IN} = V_{CC} / 2$
OUT VOLTAGE LOW			0.4	V	$IN+ < IN-, I_{SINK} = 1.2\text{ mA}$
OUT VOLTAGE HIGH (ADCMP371)	$0.8V_{CC}$			V	$IN+ > IN-, I_{SOURCE} = 500\ \mu\text{A}$
OUT LEAKAGE CURRENT (ADCMP370)			1	μA	$IN+ > IN-, OUT = 22\text{ V}$
Output Rise Time		30		ns	$C_{OUT} = 15\text{ pF}$
Output Fall Time		45		ns	$C_{OUT} = 15\text{ pF}$
TIMING					
Propagation Delay		5		μs	Input overdrive = 10 mV
		2		μs	Input overdrive = 100 mV

ADCMP370/ADCMP371

ABSOLUTE MAXIMUM RATINGS

$T_A = 25^\circ\text{C}$, unless otherwise noted.

Table 2.

Parameter	Rating
V_{CC}	-0.3 V to +6 V
IN+, IN-	-0.3 V to +25 V
OUT (ADCMP370)	-0.3 V to +25 V
OUT (ADCMP371)	-0.3 V to $V_{CC} + 0.3$ V
Operating Temperature Range	-40°C to +85°C
Storage Temperature Range	-65°C to +150°C
θ_{JA} Thermal Impedance, SC70	146°C/W
Lead Temperature	
Soldering (10 sec)	300°C
Vapor Phase (60 sec)	215°C
Infrared (15 sec)	220°C

Stresses above those listed under Absolute Maximum Ratings may cause permanent damage to the device. This is a stress rating only; functional operation of the device at these or any other conditions above those indicated in the operational section of this specification is not implied. Exposure to absolute maximum rating conditions for extended periods may affect device reliability.

ESD CAUTION

ESD (electrostatic discharge) sensitive device. Electrostatic charges as high as 4000 V readily accumulate on the human body and test equipment and can discharge without detection. Although this product features proprietary ESD protection circuitry, permanent damage may occur on devices subjected to high energy electrostatic discharges. Therefore, proper ESD precautions are recommended to avoid performance degradation or loss of functionality.



PIN CONFIGURATION AND FUNCTION DESCRIPTIONS

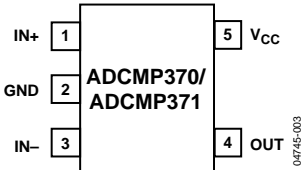

Figure 3. Pin Configuration

Table 3. Pin Function Descriptions

Pin No.	Mnemonic	Description
1	IN+	Noninverting Input.
2	GND	Ground.
3	IN-	Inverting Input.
4	OUT	Comparator Output. Open drain for ADCMP370. Push-pull for ADCMP371.
5	V _{CC}	Power Supply.

TYPICAL PERFORMANCE CHARACTERISTICS

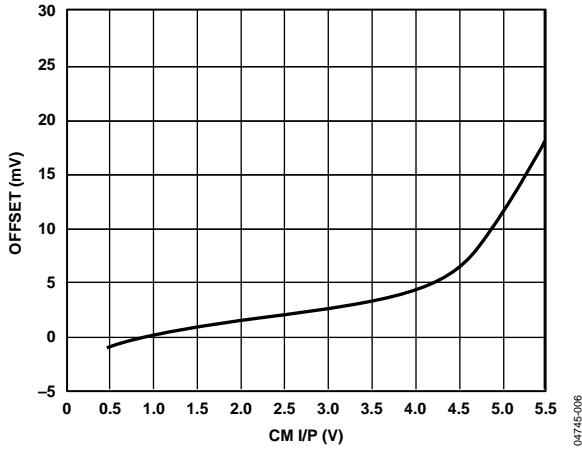

Figure 4. Input Offset vs. Common-Mode Input Voltage

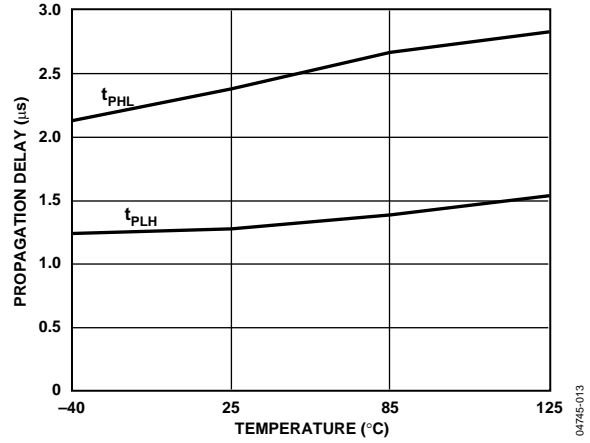

Figure 7. Propagation Delay vs. Temperature

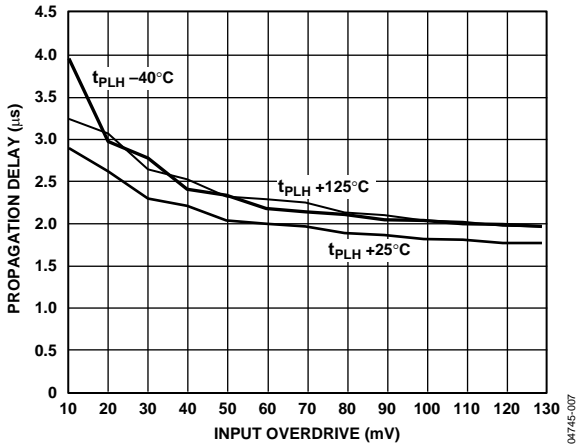

Figure 5. Propagation Delay vs. Input Overdrive (Low to High)

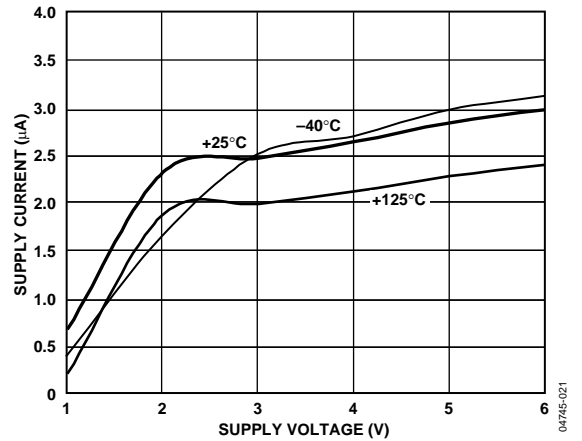

Figure 8. Supply Current vs. Supply Voltage (Output Low)

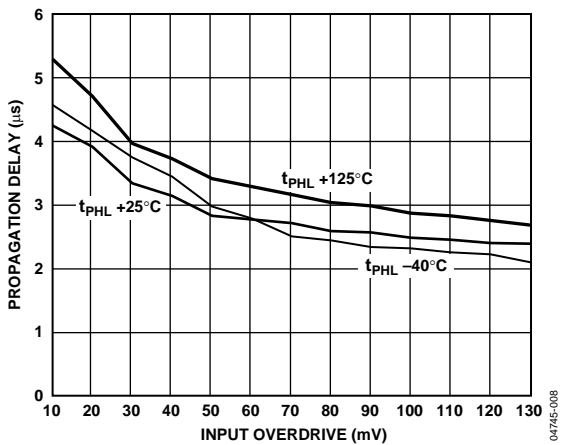

Figure 6. Propagation Delay vs. Input Overdrive (High to Low)

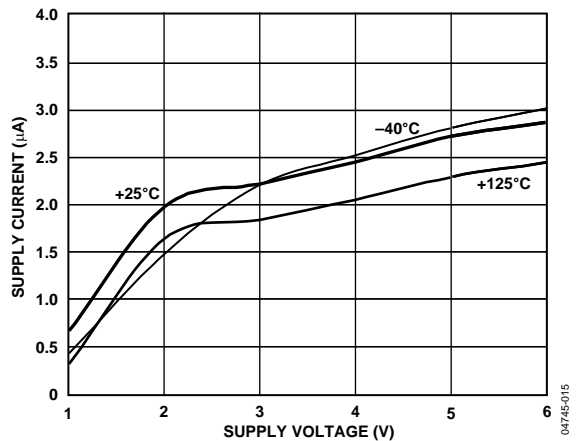

Figure 9. Supply Current vs. Supply Voltage (Output High)

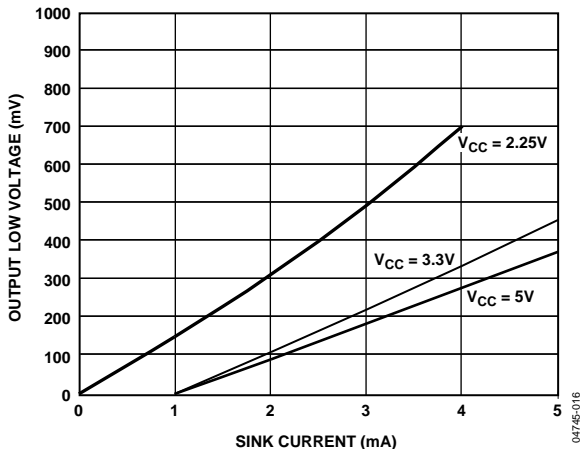

Figure 10. Output Low Voltage vs. Sink Current

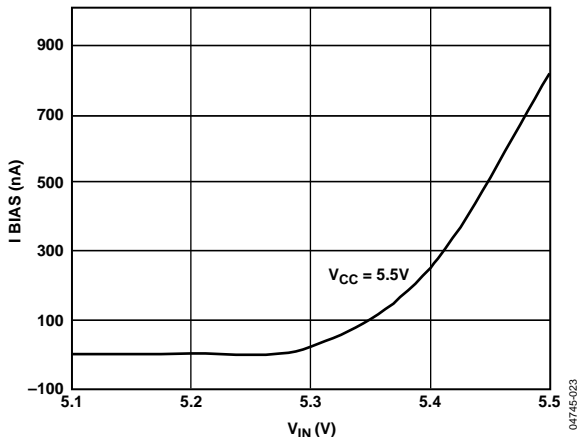

Figure 13. Input Bias Current vs. Input Voltage

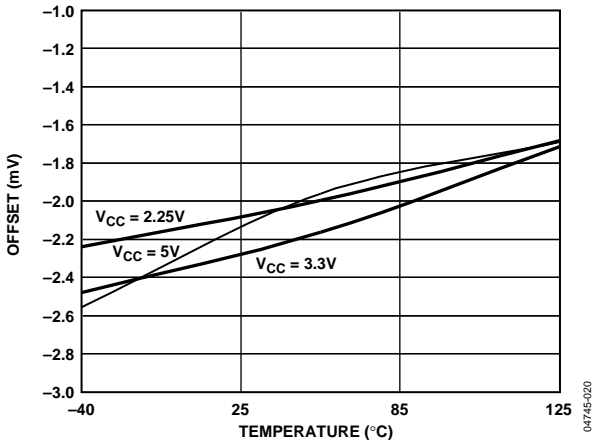

Figure 11. Input Offset vs. Temperature

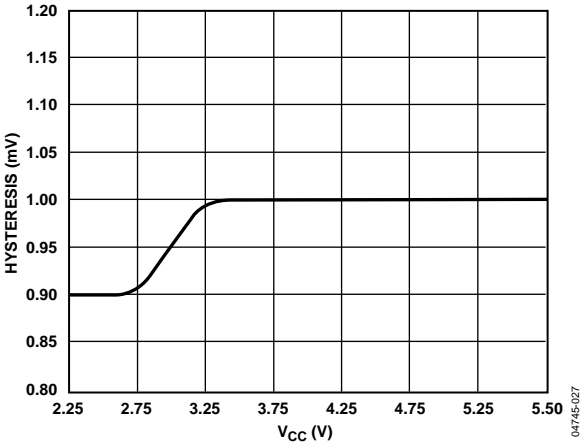

Figure 14. Hysteresis vs. Supply Voltage

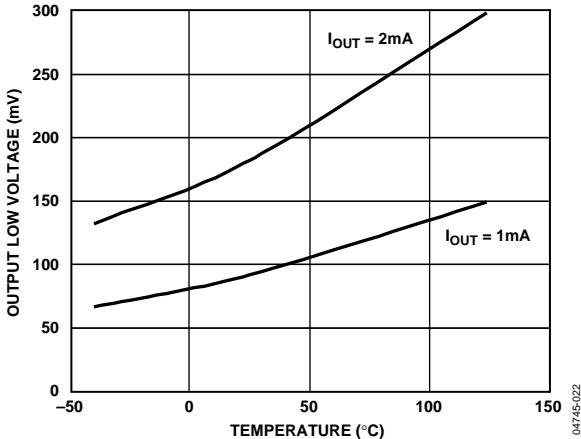

Figure 12. Output Low Voltage vs. Temperature

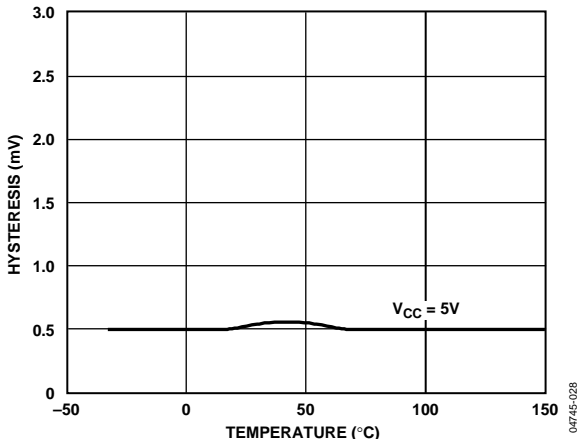

Figure 15. Hysteresis vs. Temperature

ADCMP370/ADCMP371

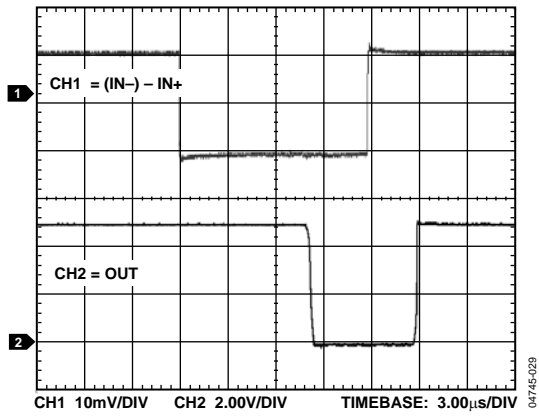

Figure 16. Propagation Delay Timing 10 mV Overdrive

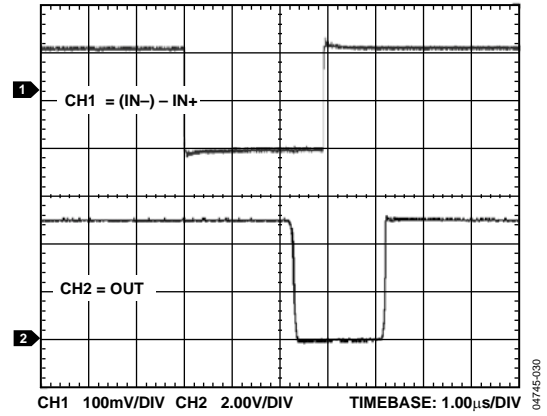

Figure 17. Propagation Delay Timing 100 mV Overdrive

APPLICATIONS

BASIC COMPARATOR

In its most basic configuration, a comparator can be used to convert an analog input signal to a digital output signal. The analog signal on IN+ is compared to the voltage on IN–, and the voltage at OUT is either high or low, depending on whether IN+ is at a higher or lower potential than IN–, respectively.

The ADCMP370 and ADCMP371 have different digital output structures. The ADCMP370 has an open-drain output stage that requires an external resistor to pull OUT to the logic high voltage level when the output transistor is switched off. This voltage level can be as high as 22 V. The same 22 V tolerance also applies to the inputs of the comparators. The pull-up resistor should be large enough to avoid excessive power dissipation but small enough to switch logic levels reasonably quickly when the comparator output is connected to other digital circuitry. A suitable value is between 1 kΩ and 10 kΩ. The ADCMP371 has a push-pull output stage, which has an internal PMOS pull-up and, therefore, does not require an external resistor. Faster switching speeds between low and high rails are possible, but the logic high level is limited to V_{CC}.

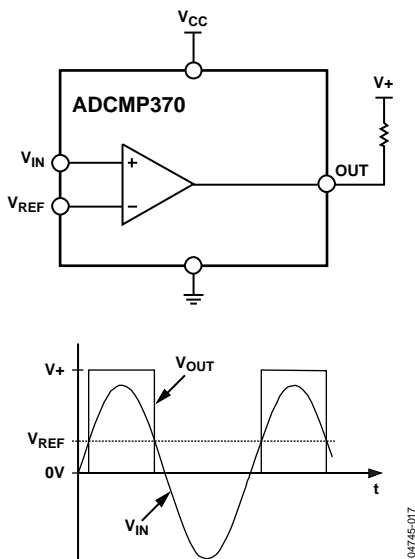

Figure 18. Basic Comparator and Input and Output Signals

ADDING HYSTERESIS

To prevent oscillations at the output caused by noise or slowly moving signals passing the switching threshold, positive feedback can be used to add hysteresis to the differential input.

For the noninverting configuration, shown in Figure 19, two resistors are used to create different switching thresholds, depending on whether the input signal is increasing or decreasing in magnitude. When the input voltage is increasing, the threshold is above V_{REF}, and when it is decreasing, the threshold is below V_{REF}.

The upper input threshold level is given by

$$V_{IN_HI} = \frac{V_{REF}(R1 + R2) - V_{CC}R1}{R2}$$

The lower input threshold level is given by

$$V_{IN_LO} = \frac{V_{REF}(R1 + R2)}{R2}$$

The hysteresis is the difference between these voltage levels

$$\Delta V_{IN} = \frac{V_{CC}R1}{R2}$$

In the example in Figure 19, Resistor R1 and Resistor R2 are chosen to give 1 V hysteresis about the reference of 2.5 V, with V_{CC} = 5 V.

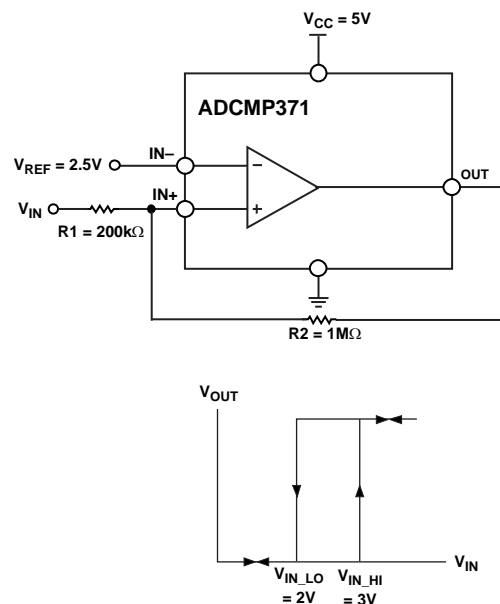

Figure 19. Noninverting ADCMP371 Comparator Configuration with Hysteresis

With the inverting configuration, the upper and lower switching thresholds are

$$V_{IN_HI} = \frac{V_{CC}R2}{(R1 \parallel R3) + R2}$$

$$V_{IN_HI} = \frac{V_{CC} \times R2(R1 + R3)}{(R1 \times R3) + (R2 \times R1) + (R2 \times R3)}$$

$$V_{IN_LO} = \frac{V_{CC}(R2 \parallel R3)}{R1 + (R2 \parallel R3)}$$

$$V_{IN_LO} = \frac{V_{CC} \times R2 \times R3}{(R1 \times R3) + (R2 \times R1) + (R2 \times R3)}$$

ADCMP370/ADCMP371

The hysteresis is the difference between these voltage levels and is given by

$$\Delta V_{IN} = \frac{V_{CC} \times R1 \times R2}{(R1 \times R3) + (R2 \times R1) + (R2 \times R3)}$$

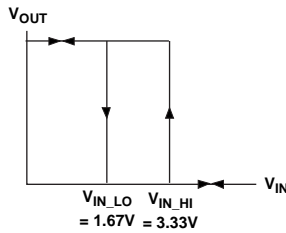
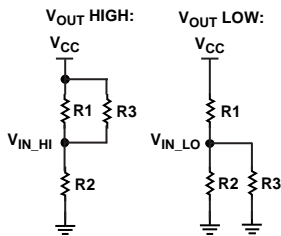
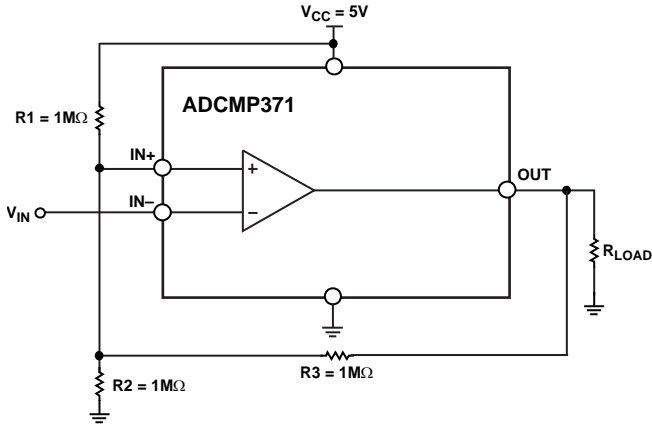

Figure 20. Inverting ADCMP371 Comparator Configuration with Hysteresis

For the ADCMP370 configuration, a pull-up resistor is required for the open-drain output, which affects the hysteresis calculation. The noninverting ADCMP370 configuration is shown in Figure 21. The upper switching threshold is

$$V_{IN_HI} = \frac{V_{REF} (R1 + R2 + R_{PULLUP}) - V_{CC} R1}{R2 + R_{PULLUP}}$$

The lower input threshold level is given by

$$V_{IN_LO} = \frac{V_{REF} (R1 + R2)}{R2}$$

The hysteresis is the difference between these voltage levels

$$\Delta V_{IN} = \frac{V_{CC} R1}{R2 + R_{PULLUP}}$$

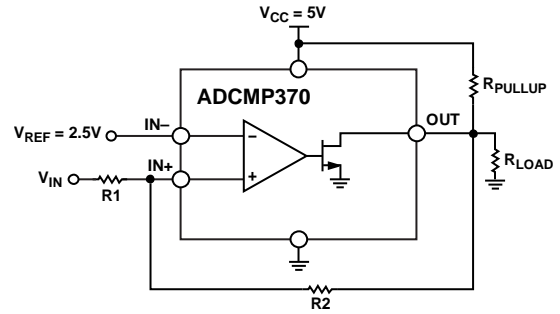

Figure 21. Noninverting ADCMP370 Comparator Configuration with Hysteresis

The inverting ADCMP370 configuration is shown in Figure 22. The upper and lower switching thresholds are

$$V_{IN_HI} = \frac{V_{CC} R2}{(R1 \parallel (R3 + R_{PULLUP})) + R2}$$

$$V_{IN_HI} = \frac{V_{CC} \times R2 (R1 + (R3 + R_{PULLUP}))}{(R1 \times (R3 + R_{PULLUP})) + (R2 \times R1) + (R2 \times (R3 + R_{PULLUP}))}$$

$$V_{IN_LO} = \frac{V_{CC} (R2 \parallel (R3 + R_{PULLUP}))}{R1 + (R2 \parallel (R3 + R_{PULLUP}))}$$

$$V_{IN_LO} = \frac{V_{CC} \times R2 \times (R3 + R_{PULLUP})}{(R1 \times (R3 + R_{PULLUP})) + (R2 \times R1) + (R2 \times (R3 + R_{PULLUP}))}$$

assuming $R_{LOAD} \gg R1, R2, R3, R_{PULLUP}$.

The hysteresis is the difference between these voltage levels and is given by

$$\Delta V_{IN} = \frac{V_{CC} \times R1 \times R2}{(R1 \times (R3 + R_{PULLUP})) + (R2 \times R1) + (R2 \times (R3 + R_{PULLUP}))}$$

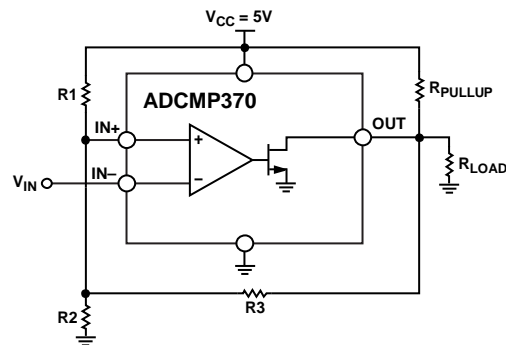
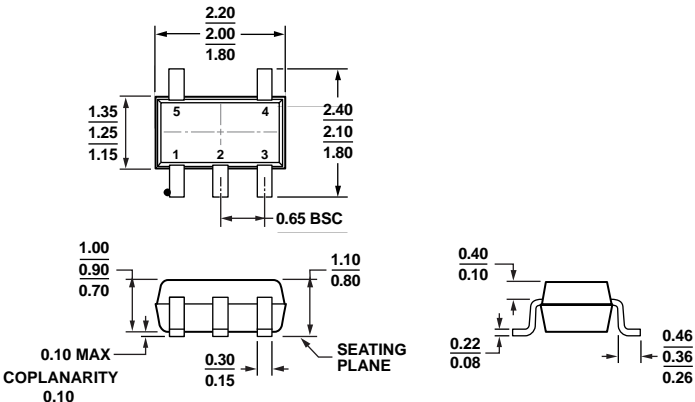

Figure 22. Inverting ADCMP370 Comparator Configuration with Hysteresis

OUTLINE DIMENSIONS



COMPLIANT TO JEDEC STANDARDS MO-203-AA

Figure 23. 5-Lead Thin Shrink Small Outline Transistor Package [SC70] (KS-5)

Dimensions shown in millimeters

07200P-A

ORDERING GUIDE

Model ¹	Temperature Range	Package Description	Package Option	Branding
ADCMP370AKS-REEL	-40°C to +85°C	5-Lead SC70	KS-5	M1F
ADCMP370AKS-REEL7	-40°C to +85°C	5-Lead SC70	KS-5	M1F
ADCMP370AKSZ-REEL	-40°C to +85°C	5-Lead SC70	KS-5	M8P
ADCMP370AKSZ-REEL7	-40°C to +85°C	5-Lead SC70	KS-5	M8P
ADCMP371AKS-REEL	-40°C to +85°C	5-Lead SC70	KS-5	M1G
ADCMP371AKS-REEL7	-40°C to +85°C	5-Lead SC70	KS-5	M1G
ADCMP371AKSZ-REEL7	-40°C to +85°C	5-Lead SC70	KS-5	M8W

¹ Z = RoHS Compliant Part.

NOTES



Компания «ЭлектроПласт» предлагает заключение долгосрочных отношений при поставках импортных электронных компонентов на взаимовыгодных условиях!

Наши преимущества:

- Оперативные поставки широкого спектра электронных компонентов отечественного и импортного производства напрямую от производителей и с крупнейших мировых складов;
- Поставка более 17-ти миллионов наименований электронных компонентов;
- Поставка сложных, дефицитных, либо снятых с производства позиций;
- Оперативные сроки поставки под заказ (от 5 рабочих дней);
- Экспресс доставка в любую точку России;
- Техническая поддержка проекта, помощь в подборе аналогов, поставка прототипов;
- Система менеджмента качества сертифицирована по Международному стандарту ISO 9001;
- Лицензия ФСБ на осуществление работ с использованием сведений, составляющих государственную тайну;
- Поставка специализированных компонентов (Xilinx, Altera, Analog Devices, Intersil, Interpoint, Microsemi, Aeroflex, Peregrine, Syfer, Eurofarad, Texas Instrument, Miteq, Cobham, E2V, MA-COM, Hittite, Mini-Circuits, General Dynamics и др.);

Помимо этого, одним из направлений компании «ЭлектроПласт» является направление «Источники питания». Мы предлагаем Вам помощь Конструкторского отдела:

- Подбор оптимального решения, техническое обоснование при выборе компонента;
- Подбор аналогов;
- Консультации по применению компонента;
- Поставка образцов и прототипов;
- Техническая поддержка проекта;
- Защита от снятия компонента с производства.



Как с нами связаться

Телефон: 8 (812) 309 58 32 (многоканальный)

Факс: 8 (812) 320-02-42

Электронная почта: org@eplast1.ru

Адрес: 198099, г. Санкт-Петербург, ул. Калинина, дом 2, корпус 4, литера А.