

REVISONS		DATE	BY	APP'D
F	REV PER ECO-07-017102	31AUG07	PY	BW

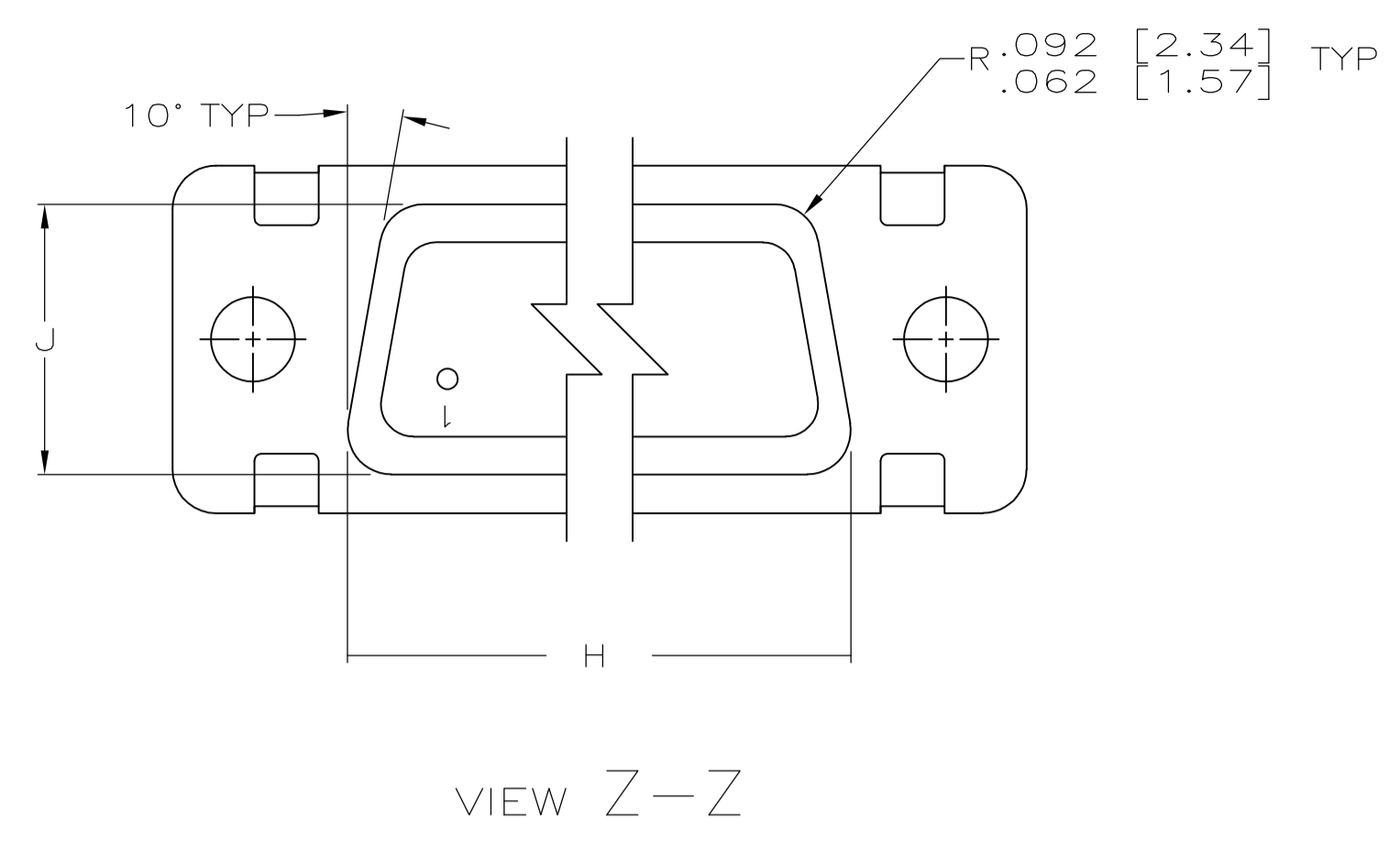

- 1 SEE SHEET 2 FOR RECOMMENDED P.C. BOARD LAYOUT. TRUE POSITION TOLERANCE FOR P.C. BOARD LAYOUT IS .010 [0.25] AT MAX MATERIAL CONDITION. SUGGESTED BOARD THICKNESS IS .094 [2.39]
- 2 THE CONNECTORS DESCRIBED IN THIS DOCUMENT MEET THE REQUIREMENTS OF MIL-C-24308 AND MATE WITH ANY RECEPTACLE CONNECTOR WITH SAME INSERT ARRANGEMENT.
- 3 MARK WITH .047 [1.19]-.062 [1.57] HIGH CHARACTERS. FAR SIDE REFERS TO THE WIDE SIDE OF THE KEYSTONE. NEAR SIDE REFERS TO THE NARROW SIDE OF THE KEYSTONE. IF THE REAR SHELL IS TOO SMALL FOR THE ENTIRE MILITARY PART NUMBER, MARKING SHALL BE LOCATED AS FOLLOWS:
 - A. "M24308" ON FRONT SHELL, FAR SIDE.
 - B. SLASH SHEET AND DASH NUMBER ON REAR SHELL, FAR SIDE.
 - C. "AMP" AND DATE CODE ON FRONT SHELL, NEAR SIDE.
 - D. AMP PART NUMBER ON REAR SHELL, NEAR SIDE.
 IF THE FRONT SHELL IS TOO SMALL FOR "AMP", AMP PART NUMBER AND DATE CODE, THEN SPLIT AS FOLLOWS:
 - A. AMP PART NUMBER ON REAR SHELL, NEAR SIDE.
 - B. "AMP" AND DATE CODE ON FRONT SHELL, NEAR SIDE.
 - C. MILITARY PART NUMBER ON REAR SHELL, FAR SIDE.

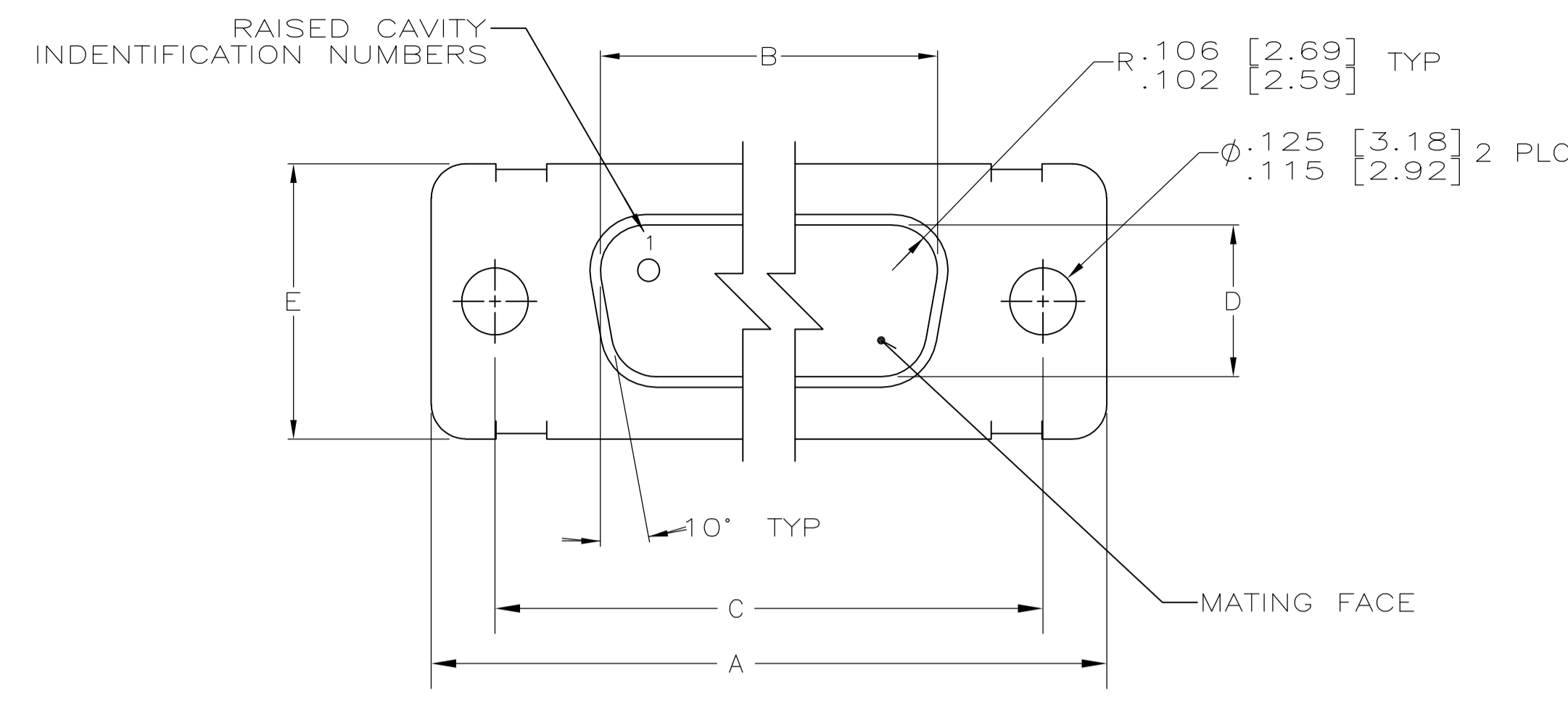
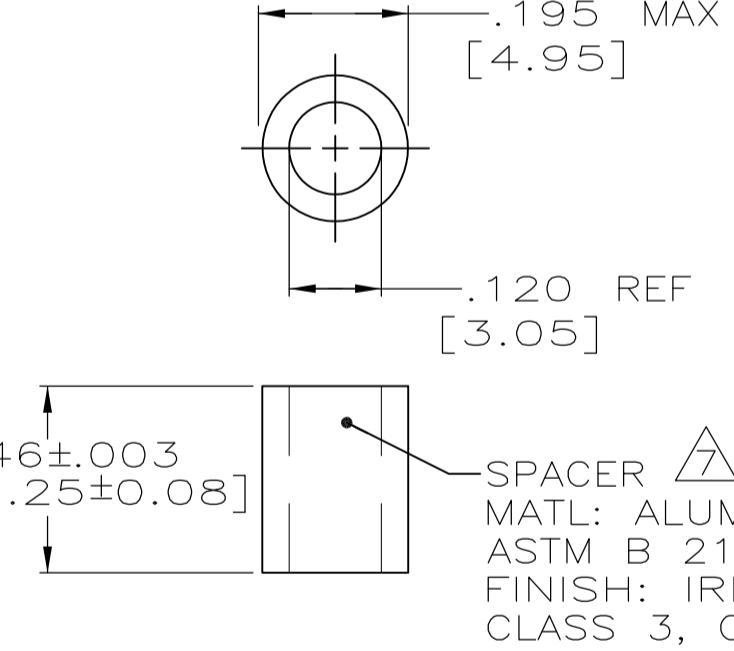
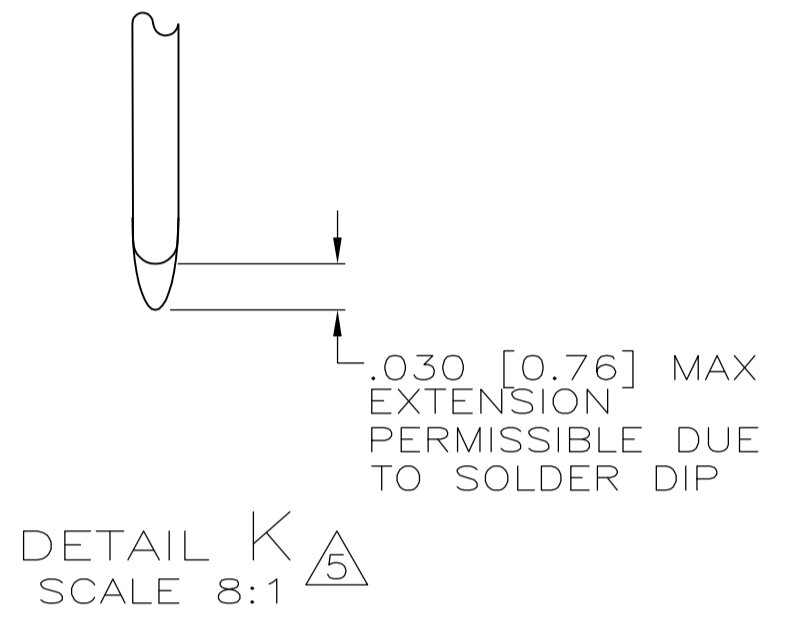
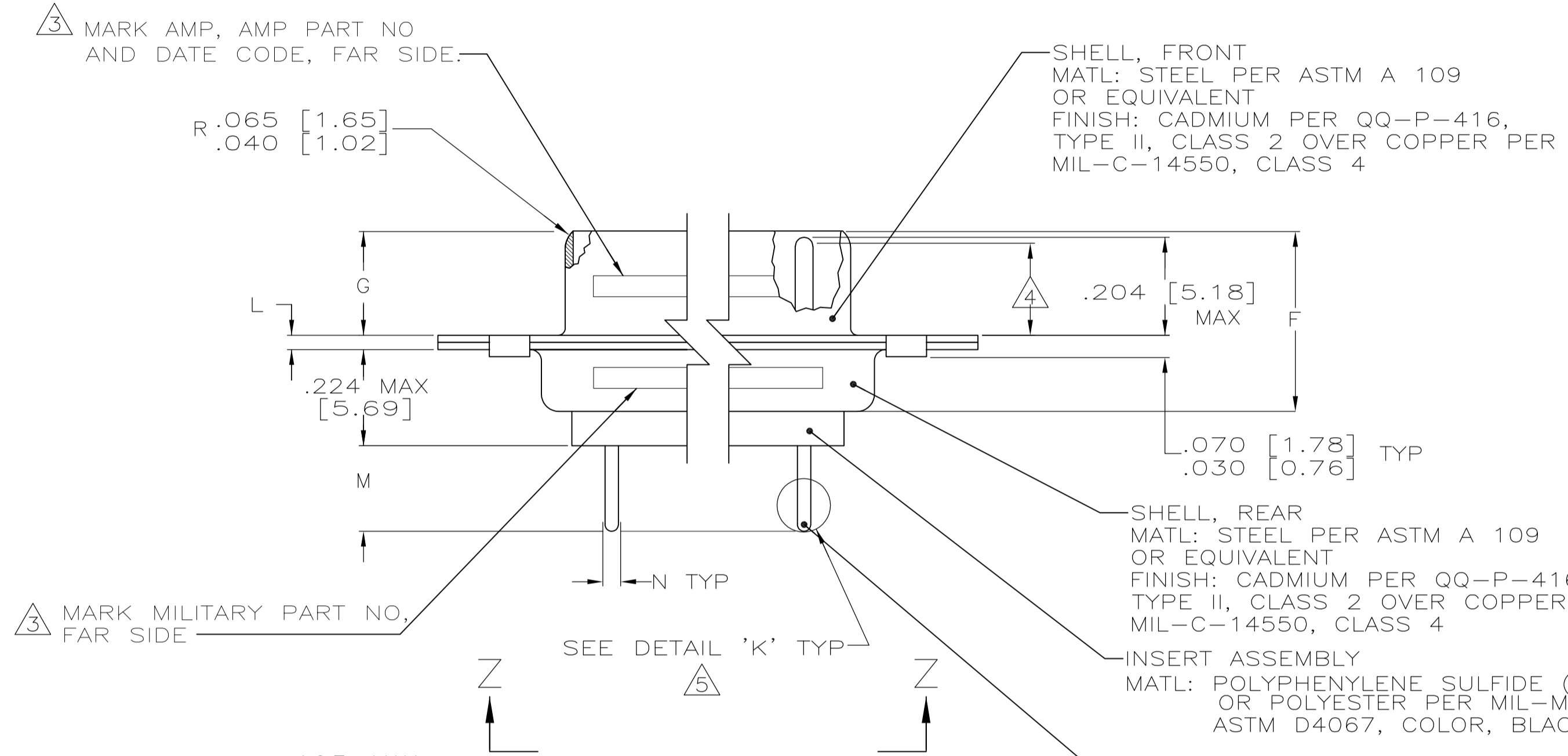

- 4 REQUIREMENT FOR FULL PIN DIAMETER EXTENSION: .159 [4.04] MIN, SHELL SIZES 1 AND 2. .150 [3.81] MIN, SHELL SIZES 3, 4, AND 5.
- 5 SOLDER DIP PER MIL-STD-2000 COMPOSITION Sn63 CONFORMING TO QQ-S-571. COVERAGE SHALL BE COMPLETE TO A DISTANCE .020 [0.51] MAX FROM INSERT ASSEMBLY.
- 6. THE SOLDER DIP PROCESS IS PERFORMED SUBSEQUENT TO THE COMPLETION OF PRODUCTION OF THE MILITARY QUALIFIED CONNECTOR. DIMENSIONS APPLY PRIOR TO SOLDER DIPPING.
- 7 SPACERS (QTY 2) ARE SUPPLIED WITH CONNECTORS (NOT ATTACHED TO THE CONNECTOR).
- 8. DIMENSIONS AND TOLERANCES PER ANSI Y14.5M-1982.
- 9. THIS DRAWING SHALL BE INTERPRETED IN ACCORDANCE WITH APPLICABLE STANDARDS LISTED IN MIL-STD-100.

N	M	L	J	H	G	F	E	D	C	B	A	INSERT ARRANGEMENT	NO OF POS	SHELL SIZE	MILITARY P/N ON CONNECTOR	AMP P/N ON CONNECTOR	PART NUMBER
.043 .037	.208 .168	.049 .029	.544 [13.82] .524 [13.31]	2.188-55.58 2.168 [55.07]	.236 [5.99]	.436 [11.07]	.620 [15.75] .590 [14.99]	.446 [11.33] .436 [11.07]	2.411 [61.24] 2.401 [60.99]	2.084 [52.93] 2.074 [52.68]	2.650 [67.31] 2.620 [66.55]	MS18277-1	50	5	M24308/24-23F	1218127-5	1-1218127-0
			1.635-41.53 1.615 [41.02]	2.282-57.96 2.262 [57.45]					1.857 [47.17] 1.847 [46.91]	2.187 [55.55] 2.177 [55.30]	2.744 [69.70] 2.714 [68.94]	MS18276-1	37	4	M24308/24-22F	1218127-4	1218127-9
[1.09 0.94]	[5.28 4.27]	.040 [1.02] .020 [0.51]	.432 [10.97] .412 [10.46]	1.635-41.53 1.615 [41.02]	.238 [6.05] .229 [5.82]	.432 [10.97] .412 [10.46]	.509 [12.93] .479 [12.17]	.334 [8.48] .324 [8.23]	1.857 [47.17] 1.847 [46.91]	1.539 [39.09] 1.529 [38.84]	2.103 [53.42] 2.073 [52.65]	MS18275-1	25	3	M24308/24-21F	1218127-3	1218127-8
			1.093-27.76 1.073 [27.25]	1.317 [33.45] 1.307 [33.20]					.999 [25.37] .989 [25.12]	1.556 [39.52] 1.526 [38.76]	MS18274-1	15	2	M24308/24-20F	1218127-2	1218127-7	
[1.09 0.94]	[5.28 4.27]	.049 [1.24] .029 [0.74]	.544 [13.82] .524 [13.31]	2.188-55.58 2.168 [55.07]	.236 [5.99] .224 [5.69]	.436 [11.07] .416 [10.57]	.620 [15.75] .590 [14.99]	.446 [11.33] .436 [11.07]	2.411 [61.24] 2.401 [60.99]	2.084 [52.93] 2.074 [52.68]	2.650 [67.31] 2.620 [66.55]	MS18277-1	50	5	M24308/24-23F	1218127-5	1218127-5
			1.635-41.53 1.615 [41.02]	2.282-57.96 2.262 [57.45]					1.857 [47.17] 1.847 [46.91]	2.187 [55.55] 2.177 [55.30]	2.744 [69.70] 2.714 [68.94]	MS18276-1	37	4	M24308/24-22F	1218127-4	1218127-4
[1.09 0.94]	[5.28 4.27]	.040 [1.02] .020 [0.51]	.432 [10.97] .412 [10.46]	1.635-41.53 1.615 [41.02]	.238 [6.05] .229 [5.82]	.432 [10.97] .412 [10.46]	.509 [12.93] .479 [12.17]	.334 [8.48] .324 [8.23]	1.857 [47.17] 1.847 [46.91]	1.539 [39.09] 1.529 [38.84]	2.103 [53.42] 2.073 [52.65]	MS18275-1	25	3	M24308/24-21F	1218127-3	1218127-3
			1.093-27.76 1.073 [27.25]	1.317 [33.45] 1.307 [33.20]					.999 [25.37] .989 [25.12]	1.556 [39.52] 1.526 [38.76]	MS18274-1	15	2	M24308/24-20F	1218127-2	1218127-2	
[1.09 0.94]	[5.28 4.27]	.049 [1.24] .029 [0.74]	.544 [13.82] .524 [13.31]	2.188-55.58 2.168 [55.07]	.236 [5.99] .229 [5.82]	.436 [11.07] .416 [10.57]	.620 [15.75] .590 [14.99]	.446 [11.33] .436 [11.07]	2.411 [61.24] 2.401 [60.99]	2.084 [52.93] 2.074 [52.68]	2.650 [67.31] 2.620 [66.55]	MS18277-1	50	5	M24308/24-23F	1218127-5	1218127-5
			1.635-41.53 1.615 [41.02]	2.282-57.96 2.262 [57.45]					1.857 [47.17] 1.847 [46.91]	2.187 [55.55] 2.177 [55.30]	2.744 [69.70] 2.714 [68.94]	MS18276-1	37	4	M24308/24-22F	1218127-4	1218127-4
[1.09 0.94]	[5.28 4.27]	.040 [1.02] .020 [0.51]	.432 [10.97] .412 [10.46]	1.635-41.53 1.615 [41.02]	.238 [6.05] .229 [5.82]	.432 [10.97] .412 [10.46]	.509 [12.93] .479 [12.17]	.334 [8.48] .324 [8.23]	1.857 [47.17] 1.847 [46.91]	1.539 [39.09] 1.529 [38.84]	2.103 [53.42] 2.073 [52.65]	MS18275-1	25	3	M24308/24-21F	1218127-3	1218127-3
			1.093-27.76 1.073 [27.25]	1.317 [33.45] 1.307 [33.20]					.999 [25.37] .989 [25.12]	1.556 [39.52] 1.526 [38.76]	MS18274-1	15	2	M24308/24-20F	1218127-2	1218127-2	
[1.09 0.94]	[5.28 4.27]	.049 [1.24] .029 [0.74]	.544 [13.82] .524 [13.31]	2.188-55.58 2.168 [55.07]	.236 [5.99] .229 [5.82]	.436 [11.07] .416 [10.57]	.620 [15.75] .590 [14.99]	.446 [11.33] .436 [11.07]	2.411 [61.24] 2.401 [60.99]	2.084 [52.93] 2.074 [52.68]	2.650 [67.31] 2.620 [66.55]	MS18277-1	50	5	M24308/24-23F	1218127-5	1218127-5
			1.635-41.53 1.615 [41.02]	2.282-57.96 2.262 [57.45]					1.857 [47.17] 1.847 [46.91]	2.187 [55.55] 2.177 [55.30]	2.744 [69.70] 2.714 [68.94]	MS18276-1	37	4	M24308/24-22F	1218127-4	1218127-4
[1.09 0.94]	[5.28 4.27]	.040 [1.02] .020 [0.51]	.432 [10.97] .412 [10.46]	1.635-41.53 1.615 [41.02]	.238 [6.05] .229 [5.82]	.432 [10.97] .412 [10.46]	.509 [12.93] .479 [12.17]	.334 [8.48] .324 [8.23]	1.857 [47.17] 1.847 [46.91]	1.539 [39.09] 1.529 [38.84]	2.103 [53.42] 2.073 [52.65]	MS18275-1	25	3	M24308/24-21F	1218127-3	1218127-3
			1.093-27.76 1.073 [27.25]	1.317 [33.45] 1.307 [33.20]					.999 [25.37] .989 [25.12]	1.556 [39.52] 1.526 [38.76]	MS18274-1	15	2	M24308/24-20F	1218127-2	1218127-2	
[1.09 0.94]	[5.28 4.27]	.049 [1.24] .029 [0.74]	.544 [13.82] .524 [13.31]	2.188-55.58 2.168 [55.07]	.236 [5.99] .229 [5.82]	.436 [11.07] .416 [10.57]	.620 [15.75] .590 [14.99]	.446 [11.33] .436 [11.07]	2.411 [61.24] 2.401 [60.99]	2.084 [52.93] 2.074 [52.68]	2.650 [67.31] 2.620 [66.55]	MS18277-1	50	5	M24308/24-23F	1218127-5	1218127-5
			1.635-41.53 1.615 [41.02]	2.282-57.96 2.262 [57.45]					1.857 [47.17] 1.847 [46.91]	2.187 [55.55] 2.177 [55.30]	2.744 [69.70] 2.714 [68.94]	MS18276-1	37	4	M24308/24-22F	1218127-4	1218127-4
[1.09 0.94]	[5.28 4.27]	.040 [1.02] .020 [0.51]	.432 [10.97] .412 [10.46]	1.635-41.53 1.615 [41.02]	.238 [6.05] .229 [5.82]	.432 [10.97] .412 [10.46]	.509 [12.93] .479 [12.17]	.334 [8.48] .324 [8.23]	1.857 [47.17] 1.847 [46.91]	1.539 [39.09] 1.529 [38.84]	2.103 [53.42] 2.073 [52.65]	MS18275-1	25	3	M24308/24-21F	1218127-3	1218127-3
			1.093-27.76 1.073 [27.25]	1.317 [33.45] 1.307 [33.20]					.999 [25.37] .989 [25.12]	1.556 [39.52] 1.526 [38.76]	MS18274-1	15	2	M24308/24-20F	1218127-2	1218127-2	

THIS DRAWING IS A CONTROLLED DOCUMENT.

DIMENSIONS: INCHES	TOLERANCES UNLESS OTHERWISE SPECIFIED:	0 PLC ± -	1 PLC ± -	2 PLC ± -	3 PLC ± -	4 PLC ± -	ANGLES ± -
--------------------	--	-----------	-----------	-----------	-----------	-----------	------------

MATERIAL: SEE CALLOUTS FINISH: SEE CALLOUTS

WEIGHT: -

CUSTOMER DRAWING

SCALE: 4:1 SHEET 1 OF 2 REV F

TYCO ELECTRONICS CORPORATION
HARRISBURG, PA 17105-3608

AMPLIMITE PLUG ASSY, LOW PROFILE
SIZE 20 POSTED, .040 DIA LONG POST
SERIES 109, SHELL SIZES 1 THRU 5

SIZE: A1 CASE CODE: 00779 DRAWING NO: 1218127

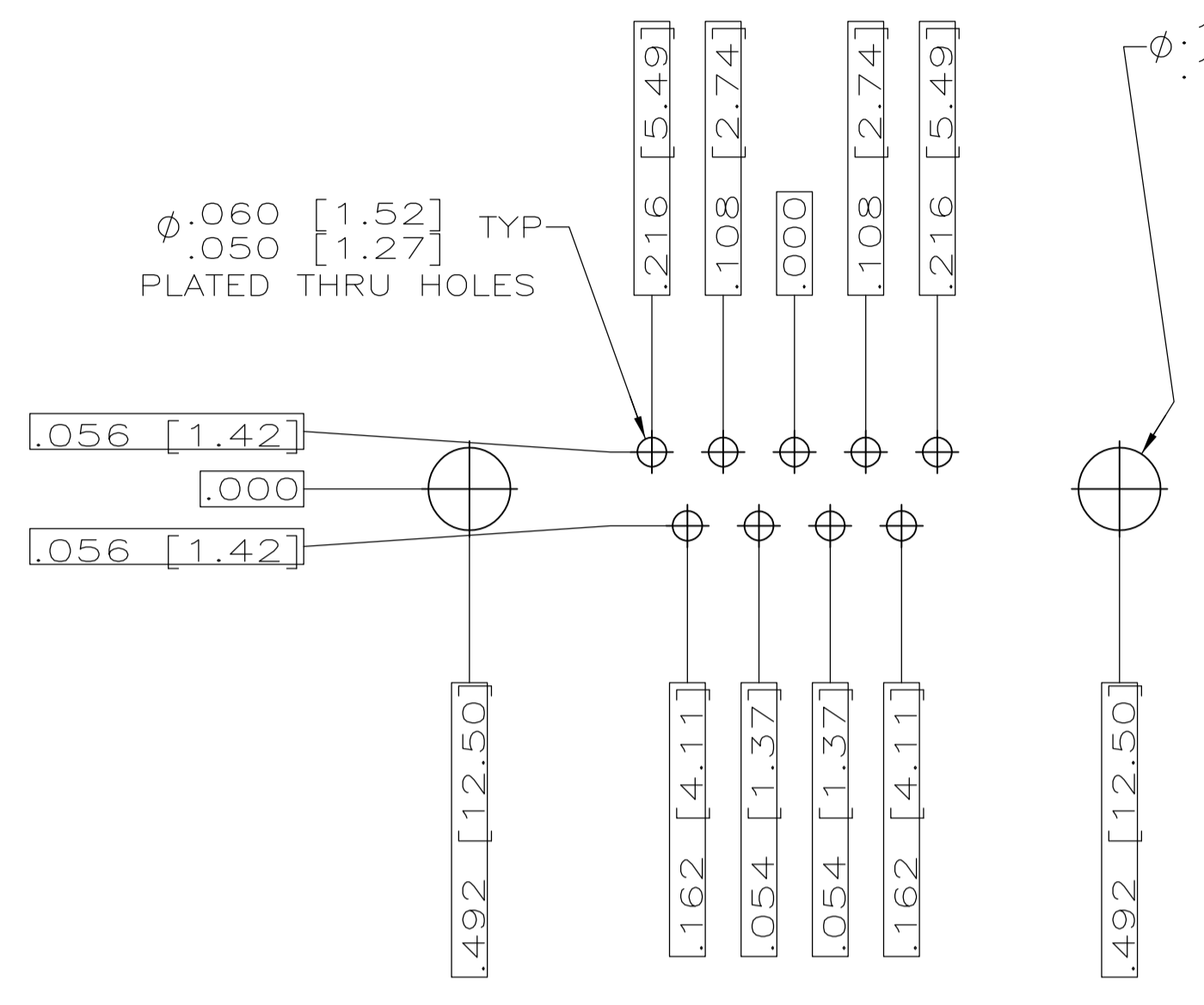

RECOMMENDED P.C. BOARD LAYOUT
SHELL SIZE 1 (9 POSITION) ⚠

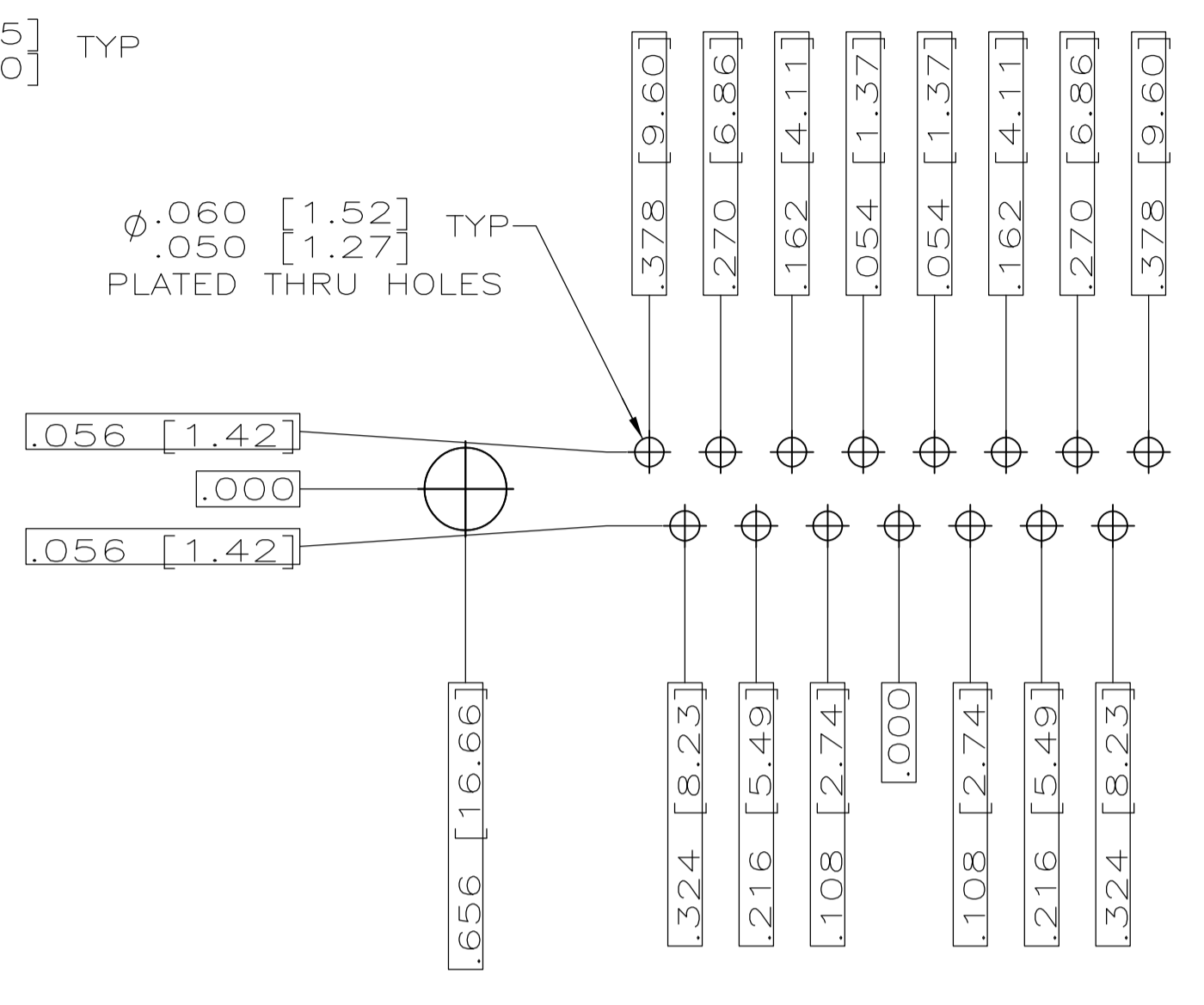

RECOMMENDED P.C. BOARD LAYOUT
SHELL SIZE 2 (15 POSITION) ⚠

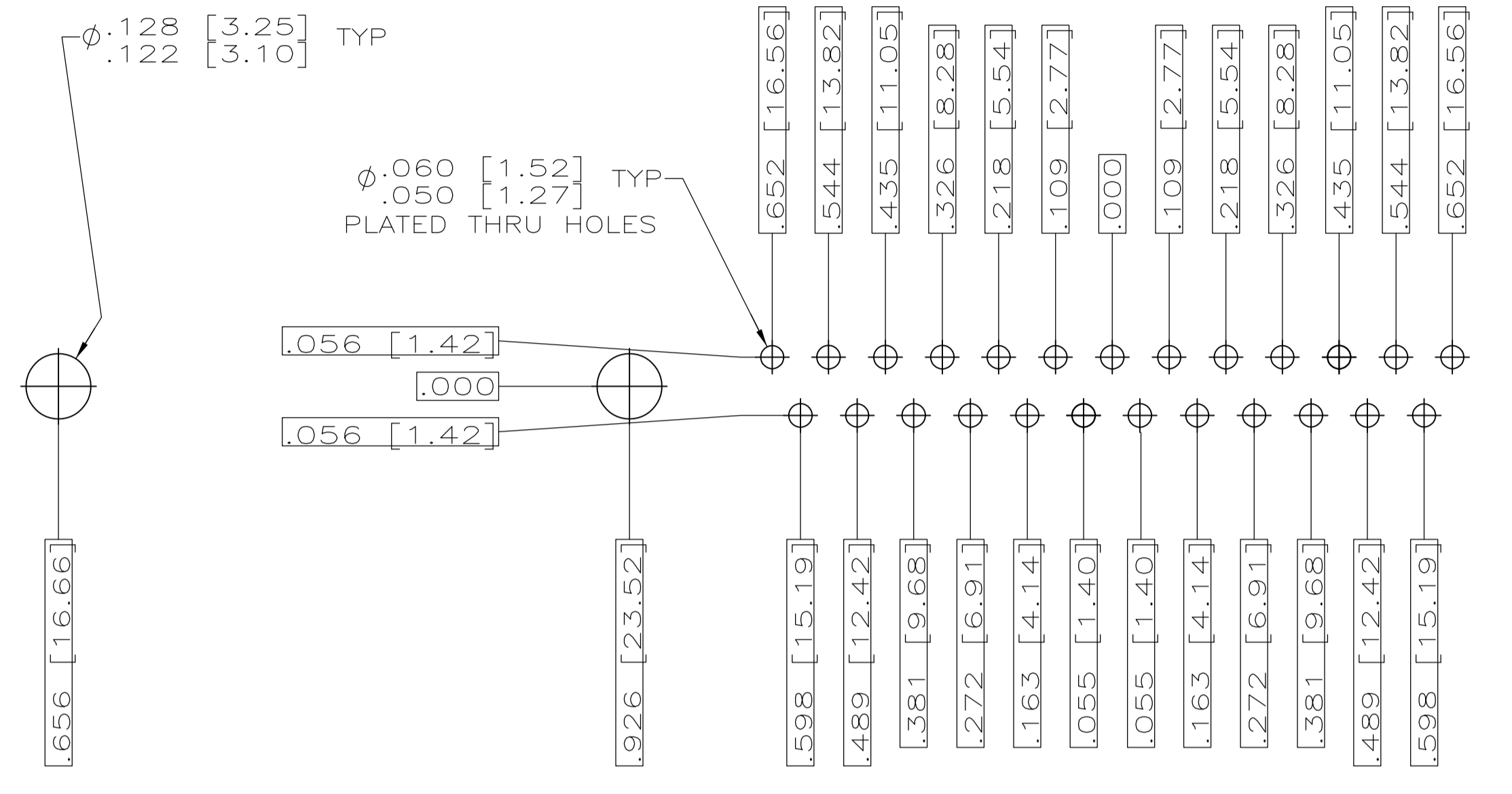

RECOMMENDED P.C. BOARD LAYOUT
SHELL SIZE 3 (25 POSITION) ⚠

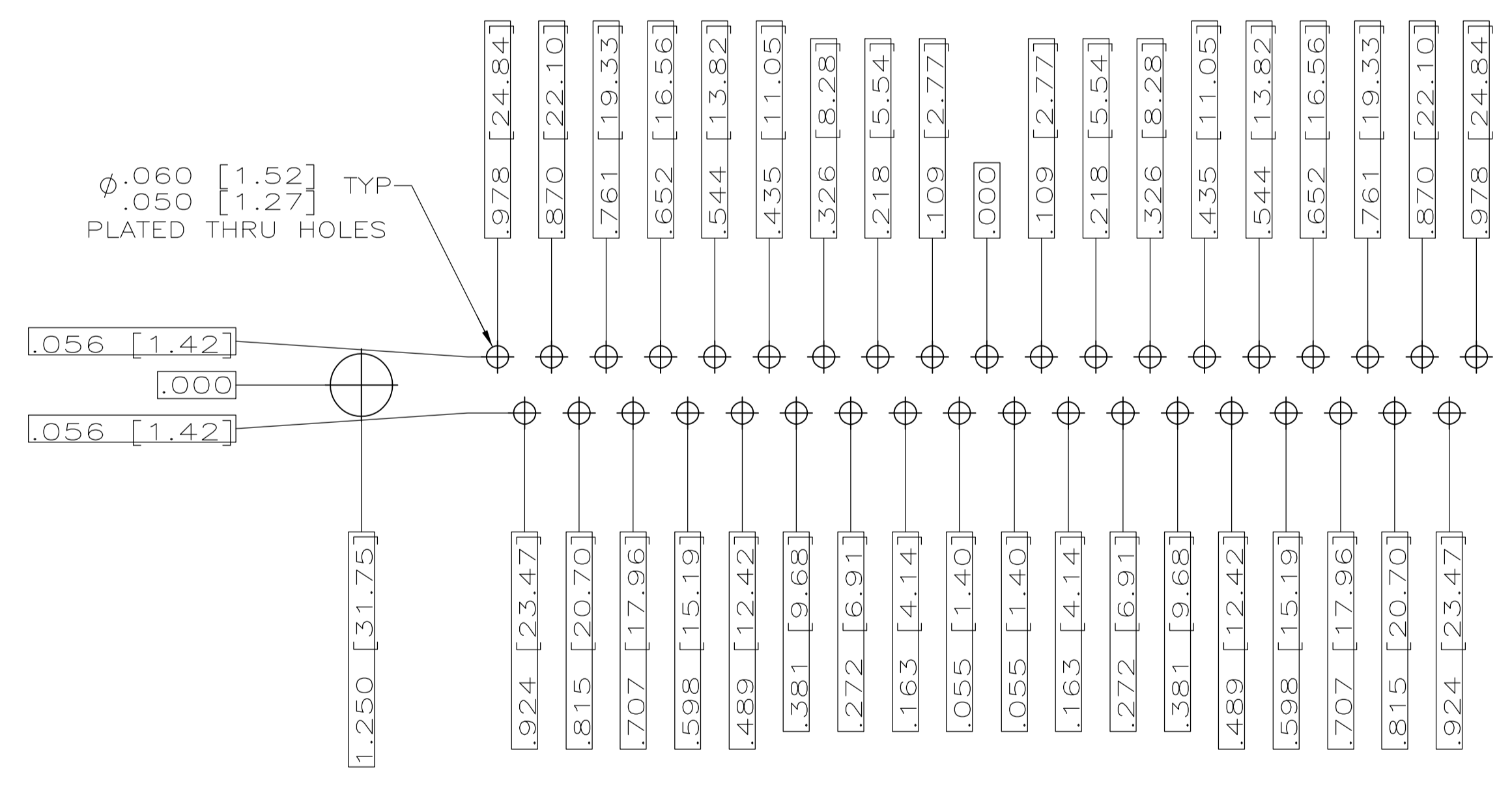

RECOMMENDED P.C. BOARD LAYOUT
SHELL SIZE 4 (37 POSITION) ⚠

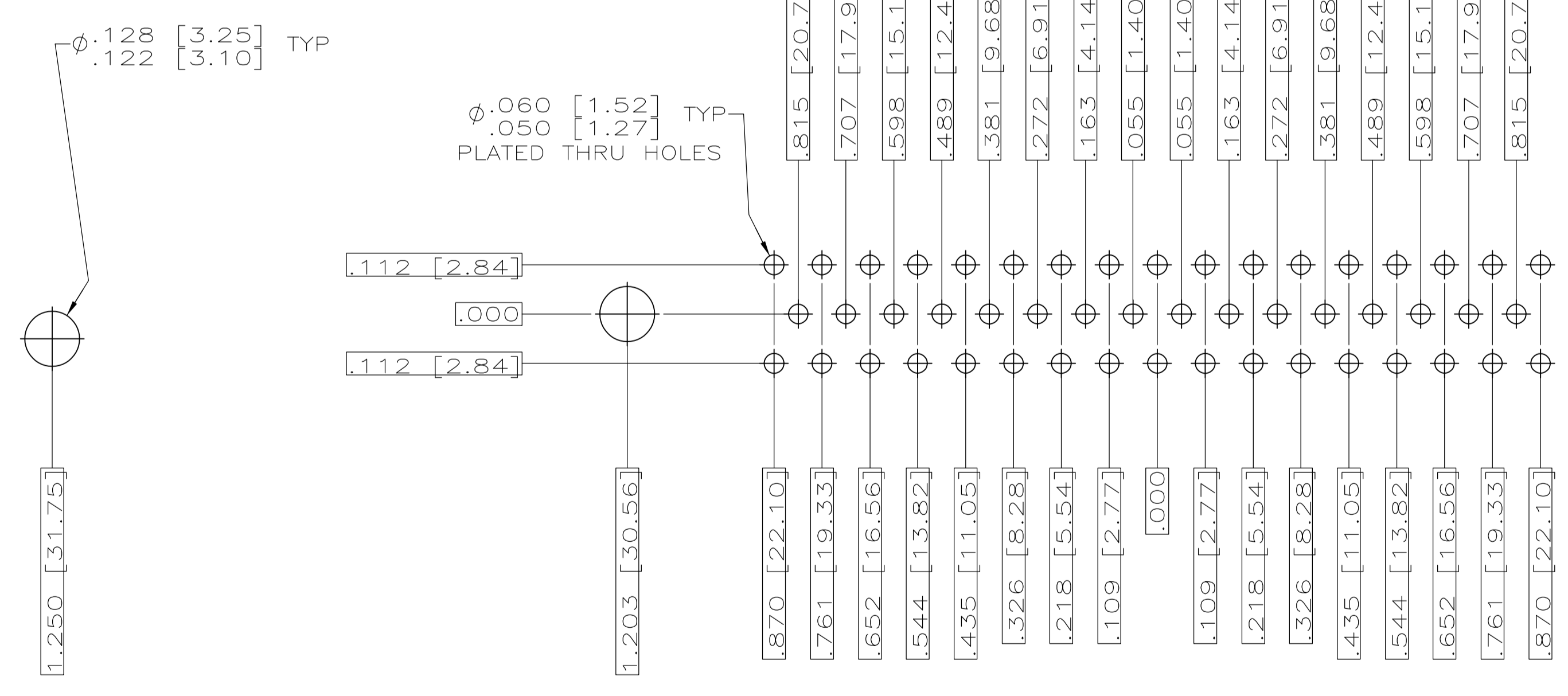

RECOMMENDED P.C. BOARD LAYOUT
SHELL SIZE 5 (50 POSITION) ⚠

THIS DRAWING IS A CONTROLLED DOCUMENT.		DIN P. YEAGER 30DEC97	Tyco Electronics Corporation Harrisburg, PA 17105-3608
DIMENSIONS: INCHES		CHK G. OVER 30DEC97	
TOLERANCES UNLESS OTHERWISE SPECIFIED:		APVD G. OVER 30DEC97	NAME AMPLIMITE PLUG ASSY, LOW PROFILE SIZE 20 POSTED P.C. BOARD CONTACTS, .040 DIA LONG POST, SERIES 109.
0 PL ± .005		PRODUCT SPEC	
1 PL ± .005		APPLICATION SPEC	SIZE A1
2 PL ± .005		WEIGHT	CAGE CODE 00779
3 PL ± .005		CUSTOMER DRAWING	DRAWING NO. 1218127
4 PL ± .005		SCALE 4:1	SHEET 2 OF 2
FINISH		RESTRICTED TO	REV F



Компания «ЭлектроПласт» предлагает заключение долгосрочных отношений при поставках импортных электронных компонентов на взаимовыгодных условиях!

Наши преимущества:

- Оперативные поставки широкого спектра электронных компонентов отечественного и импортного производства напрямую от производителей и с крупнейших мировых складов;
- Поставка более 17-ти миллионов наименований электронных компонентов;
- Поставка сложных, дефицитных, либо снятых с производства позиций;
- Оперативные сроки поставки под заказ (от 5 рабочих дней);
- Экспресс доставка в любую точку России;
- Техническая поддержка проекта, помощь в подборе аналогов, поставка прототипов;
- Система менеджмента качества сертифицирована по Международному стандарту ISO 9001;
- Лицензия ФСБ на осуществление работ с использованием сведений, составляющих государственную тайну;
- Поставка специализированных компонентов (Xilinx, Altera, Analog Devices, Intersil, Interpoint, Microsemi, Aeroflex, Peregrine, Syfer, Eurofarad, Texas Instrument, Miteq, Cobham, E2V, MA-COM, Hittite, Mini-Circuits, General Dynamics и др.);

Помимо этого, одним из направлений компании «ЭлектроПласт» является направление «Источники питания». Мы предлагаем Вам помощь Конструкторского отдела:

- Подбор оптимального решения, техническое обоснование при выборе компонента;
- Подбор аналогов;
- Консультации по применению компонента;
- Поставка образцов и прототипов;
- Техническая поддержка проекта;
- Защита от снятия компонента с производства.



Как с нами связаться

Телефон: 8 (812) 309 58 32 (многоканальный)

Факс: 8 (812) 320-02-42

Электронная почта: org@eplast1.ru

Адрес: 198099, г. Санкт-Петербург, ул. Калинина, дом 2, корпус 4, литера А.