



MCP661
Line Driver
Demo Board
User's Guide

Note the following details of the code protection feature on Microchip devices:

- Microchip products meet the specification contained in their particular Microchip Data Sheet.
- Microchip believes that its family of products is one of the most secure families of its kind on the market today, when used in the intended manner and under normal conditions.
- There are dishonest and possibly illegal methods used to breach the code protection feature. All of these methods, to our knowledge, require using the Microchip products in a manner outside the operating specifications contained in Microchip's Data Sheets. Most likely, the person doing so is engaged in theft of intellectual property.
- Microchip is willing to work with the customer who is concerned about the integrity of their code.
- Neither Microchip nor any other semiconductor manufacturer can guarantee the security of their code. Code protection does not mean that we are guaranteeing the product as "unbreakable."

Code protection is constantly evolving. We at Microchip are committed to continuously improving the code protection features of our products. Attempts to break Microchip's code protection feature may be a violation of the Digital Millennium Copyright Act. If such acts allow unauthorized access to your software or other copyrighted work, you may have a right to sue for relief under that Act.

Information contained in this publication regarding device applications and the like is provided only for your convenience and may be superseded by updates. It is your responsibility to ensure that your application meets with your specifications. MICROCHIP MAKES NO REPRESENTATIONS OR WARRANTIES OF ANY KIND WHETHER EXPRESS OR IMPLIED, WRITTEN OR ORAL, STATUTORY OR OTHERWISE, RELATED TO THE INFORMATION, INCLUDING BUT NOT LIMITED TO ITS CONDITION, QUALITY, PERFORMANCE, MERCHANTABILITY OR FITNESS FOR PURPOSE. Microchip disclaims all liability arising from this information and its use. Use of Microchip devices in life support and/or safety applications is entirely at the buyer's risk, and the buyer agrees to defend, indemnify and hold harmless Microchip from any and all damages, claims, suits, or expenses resulting from such use. No licenses are conveyed, implicitly or otherwise, under any Microchip intellectual property rights.

Trademarks

The Microchip name and logo, the Microchip logo, dsPIC, KEELOQ, KEELOQ logo, MPLAB, PIC, PICmicro, PICSTART, rfPIC and UNI/O are registered trademarks of Microchip Technology Incorporated in the U.S.A. and other countries.

FilterLab, Hampshire, HI-TECH C, Linear Active Thermistor, MXDEV, MXLAB, SEEVAL and The Embedded Control Solutions Company are registered trademarks of Microchip Technology Incorporated in the U.S.A.

Analog-for-the-Digital Age, Application Maestro, CodeGuard, dsPICDEM, dsPICDEM.net, dsPICworks, dsSPEAK, ECAN, ECONOMONITOR, FanSense, HI-TIDE, In-Circuit Serial Programming, ICSP, ICEPIC, Mindi, MiWi, MPASM, MPLAB Certified logo, MPLIB, MPLINK, mTouch, Omniscent Code Generation, PICC, PICC-18, PICKit, PICDEM, PICDEM.net, PICTail, PIC³² logo, REAL ICE, rLAB, Select Mode, Total Endurance, TSHARC, WiperLock and ZENA are trademarks of Microchip Technology Incorporated in the U.S.A. and other countries.

SQTP is a service mark of Microchip Technology Incorporated in the U.S.A.

All other trademarks mentioned herein are property of their respective companies.

© 2009, Microchip Technology Incorporated, Printed in the U.S.A., All Rights Reserved.

 Printed on recycled paper.

QUALITY MANAGEMENT SYSTEM
CERTIFIED BY DNV
== ISO/TS 16949:2002 ==

Microchip received ISO/TS-16949:2002 certification for its worldwide headquarters, design and wafer fabrication facilities in Chandler and Tempe, Arizona; Gresham, Oregon and design centers in California and India. The Company's quality system processes and procedures are for its PIC[®] MCUs and dsPIC[®] DSCs, KEELOQ[®] code hopping devices, Serial EEPROMs, microperipherals, nonvolatile memory and analog products. In addition, Microchip's quality system for the design and manufacture of development systems is ISO 9001:2000 certified.



MCP661 LINE DRIVER DEMO BOARD USER'S GUIDE

Table of Contents

Preface	1
Introduction.....	1
Document Layout	1
Conventions Used in this Guide	2
Recommended Reading.....	3
The Microchip Web Site	3
Customer Support	3
Document Revision History	3
Chapter 1. Product Overview	
1.1 Introduction	5
1.2 Kit Contents	5
1.3 Intended Use	6
1.4 Description	6
Chapter 2. Installation and Operation	
2.1 Introduction	9
2.2 Required Tools	9
2.3 Configuring the Lab Equipment and PCB	10
Appendix A. Schematics and Layouts	
A.1 Introduction	11
A.2 Board – Schematic	12
A.3 Board – Top Silk Screen, Top Solder Mask and Top Metal	13
A.4 Board – Top Silk Screen and Top Solder Mask	13
A.5 Board – Bottom Metal Layer (Top View)	14
A.6 Board – Bottom Metal Layer (Bottom View)	14
Appendix B. Bill Of Materials (BOM)	
B.1 MCP661 Line Driver Demo Board BOM	15
Worldwide Sales and Service	16

MCP661 Line Driver Demo Board User's Guide

NOTES:



MCP661 LINE DRIVER DEMO BOARD USER'S GUIDE

Preface

NOTICE TO CUSTOMERS

All documentation becomes dated, and this manual is no exception. Microchip tools and documentation are constantly evolving to meet customer needs, so some actual dialogs and/or tool descriptions may differ from those in this document. Please refer to our web site (www.microchip.com) to obtain the latest documentation available.

Documents are identified with a "DS" number. This number is located on the bottom of each page, in front of the page number. The numbering convention for the DS number is "DSXXXXA", where "XXXX" is the document number and "A" is the revision level of the document.

For the most up-to-date information on development tools, see the MPLAB® IDE on-line help. Select the Help menu, and then Topics to open a list of available on-line help files.

INTRODUCTION

This chapter contains general information that will be useful to know before using the MCP661 Line Driver Demo Board. Items discussed in this chapter include:

- Document Layout
- Conventions Used in this Guide
- Recommended Reading
- The Microchip Web Site
- Customer Support
- Document Revision History

DOCUMENT LAYOUT

This document describes how to use the MCP661 Line Driver Demo Board. The manual layout is as follows:

- **Chapter 1. "Product Overview"** - Important information about the MCP661 Line Driver Demo Board.
- **Chapter 2. "Installation and Operation"** – Covers the initial set-up of the MCP661 Line Driver Demo Board. It lists the required tools, shows how to set up the board and how to connect lab equipment. It then demonstrates how to use this board.
- **Appendix A. "Schematics and Layouts"** – Shows the schematic and board layouts for the MCP661 Line Driver Demo Board.
- **Appendix B. "Bill Of Materials (BOM)"** – Lists the parts used to populate the MCP661 Line Driver Demo Board. Also lists alternate components.

MCP661 Line Driver Demo Board User's Guide

CONVENTIONS USED IN THIS GUIDE

This manual uses the following documentation conventions:

DOCUMENTATION CONVENTIONS

Description	Represents	Examples
Arial font:		
Italic characters	Referenced books	<i>MPLAB[®] IDE User's Guide</i>
	Emphasized text	...is the <i>only</i> compiler...
Initial caps	A window	the Output window
	A dialog	the Settings dialog
	A menu selection	select Enable Programmer
Quotes	A field name in a window or dialog	"Save project before build"
Underlined, italic text with right angle bracket	A menu path	<u><i>File>Save</i></u>
Bold characters	A dialog button	Click OK
	A tab	Click the Power tab
N'Rnnnn	A number in verilog format, where N is the total number of digits, R is the radix and n is a digit.	4'b0010, 2'hF1
Text in angle brackets < >	A key on the keyboard	Press <Enter>, <F1>
Courier New font:		
Plain Courier New	Sample source code	#define START
	Filenames	autoexec.bat
	File paths	c:\mcc18\h
	Keywords	_asm, _endasm, static
	Command-line options	-Opa+, -Opa-
	Bit values	0, 1
	Constants	0xFF, 'A'
Italic Courier New	A variable argument	<i>file.o</i> , where <i>file</i> can be any valid filename
Square brackets []	Optional arguments	mcc18 [options] <i>file</i> [options]
Curly brackets and pipe character: { }	Choice of mutually exclusive arguments; an OR selection	errorlevel {0 1}
Ellipses...	Replaces repeated text	var_name [, var_name...]
	Represents code supplied by user	void main (void) { ... }

RECOMMENDED READING

This user's guide describes how to use MCP661 Line Driver Demo Board. Other useful documents are listed below. The following Microchip documents are available and recommended as supplemental reference resources.

MCP661/2/3/5 Data Sheet, “60 MHz, 6 mA Op Amps”, (DS22194)

Gives detailed information on the op amp family that is used as the DUT on the MCP661 Line Driver Demo Board.

THE MICROCHIP WEB SITE

Microchip provides online support via our web site at www.microchip.com. This web site is used as a means to make files and information easily available to customers. Accessible by using your favorite Internet browser, the web site contains the following information:

- **Product Support** – Data sheets and errata, application notes and sample programs, design resources, user's guides and hardware support documents, latest software releases and archived software
- **General Technical Support** – Frequently Asked Questions (FAQs), technical support requests, online discussion groups, Microchip consultant program member listing
- **Business of Microchip** – Product selector and ordering guides, latest Microchip press releases, listing of seminars and events, listings of Microchip sales offices, distributors and factory representatives

CUSTOMER SUPPORT

Users of Microchip products can receive assistance through several channels:

- Distributor or Representative
- Local Sales Office
- Field Application Engineer (FAE)
- Technical Support
- Development Systems Information Line

Customers should contact their distributor, representative or field application engineer for support. Local sales offices are also available to help customers. A listing of sales offices and locations is included in the back of this document.

Technical support is available through the web site at: <http://support.microchip.com>

DOCUMENT REVISION HISTORY

Revision A (November 2009)

- Initial Release of this Document.

MCP661 Line Driver Demo Board User's Guide

NOTES:

Chapter 1. Product Overview

1.1 INTRODUCTION

The MCP661 Line Driver Demo Board is described by the following:

- Assembly # : 114-00270-R1
- Order # : MCP661DM-LD
- Name: MCP661 Line Driver Demo Board

Items discussed in this chapter include:

- Kit Contents
- Intended Use
- Description

1.2 KIT CONTENTS

- Assembled printed circuit board, 102-00270
- Important Information "Read First"



FIGURE 1-1: MCP661 Line Driver Demo Board Kit Contents.

MCP661 Line Driver Demo Board User's Guide

1.3 INTENDED USE

The MCP661 Line Driver Demo Board shows the MCP661 used in a very basic application for high speed op amps; a 50Ω line (coax) driver. It gives:

- A 30 MHz solution
- High speed PCB layout techniques
- A means to test AC response, step response and distortion

The application circuit implemented on this PCB is discussed briefly in the MCP661/2/3/5 data sheet's application circuit section.

1.4 DESCRIPTION

1.4.1 Simplified Circuit

Figure 1-2 shows a simplified circuit diagram of the MCP661 Line Driver Demo Board. Details of the power supply and connectors have been left out.

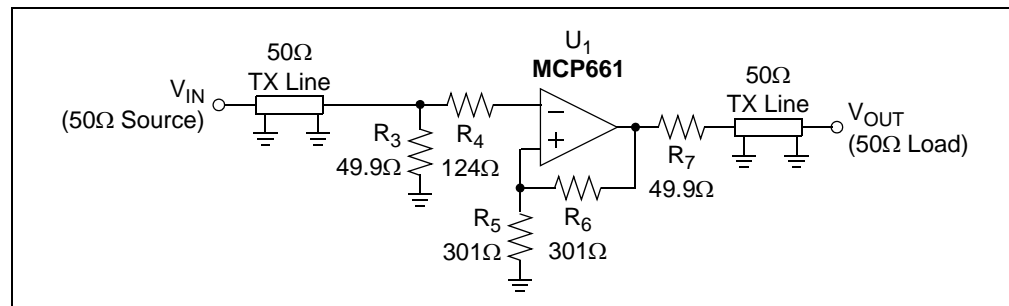

FIGURE 1-2: Simplified Circuit Diagram.

The 50Ω source drives the matched 50Ω transmission line at the input; R_3 provides this match. Thus, the input transmission line can be treated as a simple connection for circuit analysis (ignoring the time delay).

R_4 provides matched input resistances for U_1 's inputs. It also sets a pole around 100 MHz, since U_1 's C_{CM} is about 9 pF.

U_1 (MCP661) is set at a gain of 2 V/V so that the overall gain is 1 V/V (R_7 and the Load attenuate the signal by 0.5 V/V). U_1 's large output current makes it possible to drive the back-matched output transmission line (R_7 , the 50Ω line and the 50Ω load at the far end) to more than $\pm 2V$ (the load at the far end sees $\pm 1V$).

U_1 's output headroom limits would be $V_{OL} = -2.3V$ and $V_{OH} = +2.3V$, leaving some design room for the $\pm 2V$ signal. The open-loop gain (A_{OL}) typically does not decrease significantly with a 100Ω load. The maximum power dissipated by the op amp is about 48 mW, so the temperature rise (for the MCP661 in the SOIC-8 package) is under 8°C.

The output transmission line can be treated as a simple connection for circuit analysis (ignoring the time delay).

1.4.2 Power Supply

Figure 1-3 shows the power supply circuitry. R_1 and R_2 provide high frequency isolation of the supply lines. They also help with series resonances in the supplies. C_1 and C_2 provide the bulk bypassing, while C_3 and C_4 provide the local bypassing, for U_1 (MCP661).

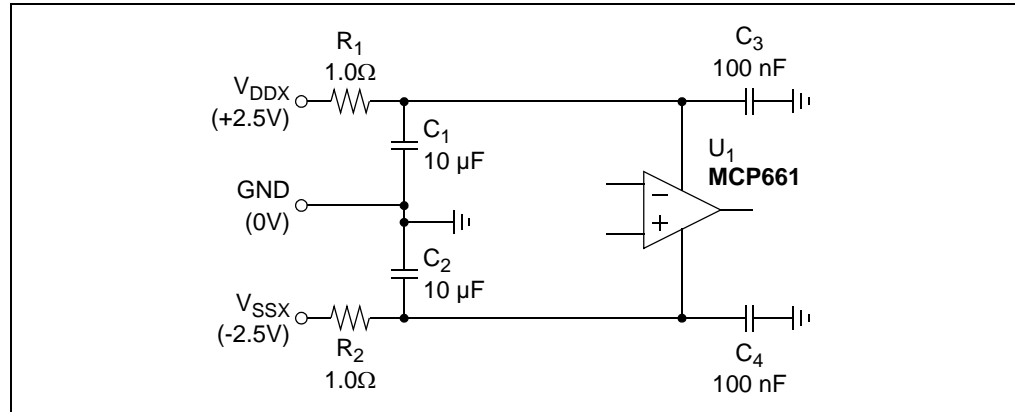

FIGURE 1-3: Power Supply.

1.4.3 Connectors and Transmission Lines

The power supplies use surface mount test points to connect to the lab supplies. The signal input and output are connected via BNC receptacles (and coax cables) to 50Ω lab equipment.

The PCB has two 50Ω transmission lines between the BNC receptacles and the matching resistors (R_3 and R_7 in Figure 1-2). They are 100 mils (2.54 mm) wide, which is a value commonly used for standard FR4 PCBs with only two layers. These lines are as long as possible; they end at the matching resistors (to avoid parasitic capacitance issues).

MCP661 Line Driver Demo Board User's Guide

NOTES:

Chapter 2. Installation and Operation

2.1 INTRODUCTION

This chapter shows how to set up and operate the MCP661 Line Driver Demo Board. Items discussed in this chapter include:

- Required Tools
- Configuring the Lab Equipment and PCB

2.2 REQUIRED TOOLS

- Lab Power Supply with dual outputs (one tracks the other):
 - For +2.5V, 0V and -2.5V
- Sine Wave Source (function generator, network analyzer, spectrum analyzer, etc):
 - Sine wave output to 100 MHz, or so
 - 50 Ω output impedance
 - -2.5V to +2.5V minimum range
- Signal Analyzer (oscilloscope, network analyzer, spectrum analyzer, etc):
 - 50 Ω input impedance
 - At least 100 MHz bandwidth

MCP661 Line Driver Demo Board User's Guide

2.3 CONFIGURING THE LAB EQUIPMENT AND PCB

Lab equipment is connected to this board as shown in Figure 2-1. The BNC receptacles and (surface mount) test points allow lab equipment to be connected to these boards.

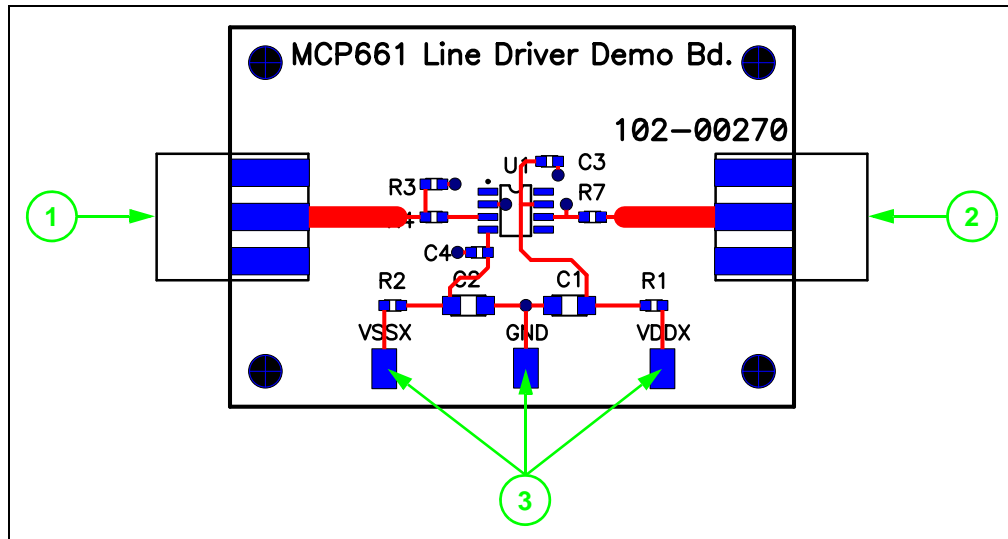

FIGURE 2-1: Lab Equipment Connections.

The arrows and numbers in the drawing signify the following:

1. BNC Recepticle for V_{IN} .
2. BNC Recepticle for V_{OUT} .
3. $\pm 2.5V$ Power Supplies, with GND, for U1 (MCP661).
 - a) $V_{DDX} = +2.5V$.
 - b) $GND = 0V$.
 - c) $V_{SSX} = -2.5V$.



MCP661 LINE DRIVER DEMO BOARD USER'S GUIDE

Appendix A. Schematics and Layouts

A.1 INTRODUCTION

This appendix contains the schematic and layouts for the MCP661 Line Driver Demo Board.

- Board – Schematic
- Board – Top Silk Screen, Top Solder Mask and Top Metal
- Board – Top Silk Screen and Top Solder Mask
- Board – Bottom Metal (Top View)
- Board – Bottom Metal (Bottom View)

The Gerber files for this board are available on the Microchip website (www.microchip.com) and are contained in the zip file "00270R1_Gerbers.zip".

A.3 BOARD – TOP SILK SCREEN, TOP SOLDER MASK AND TOP METAL

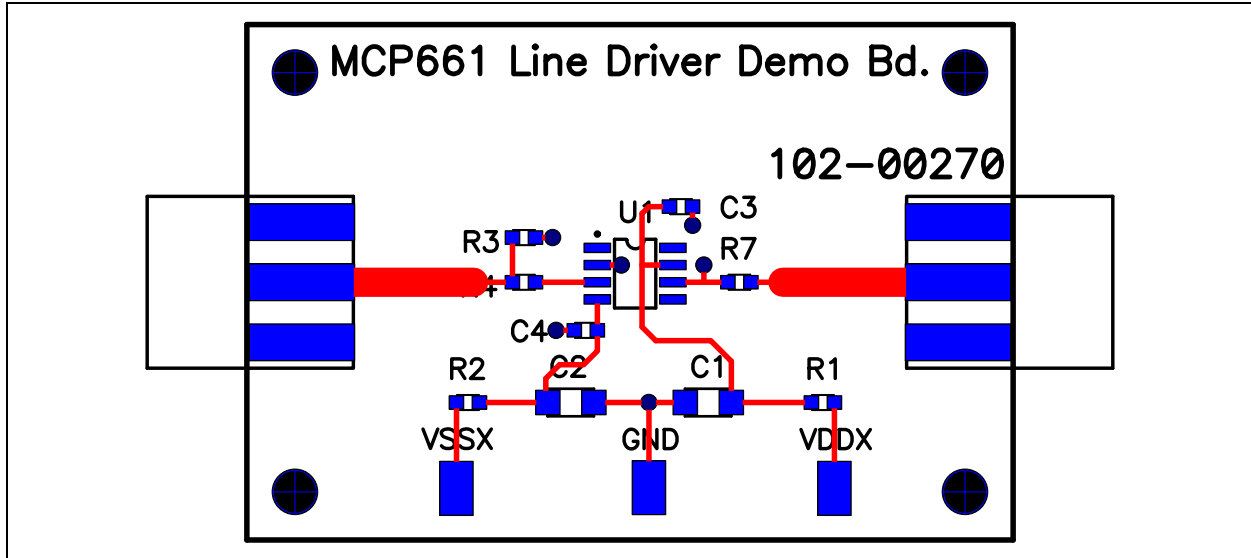

A.4 BOARD – TOP SILK SCREEN AND TOP SOLDER MASK

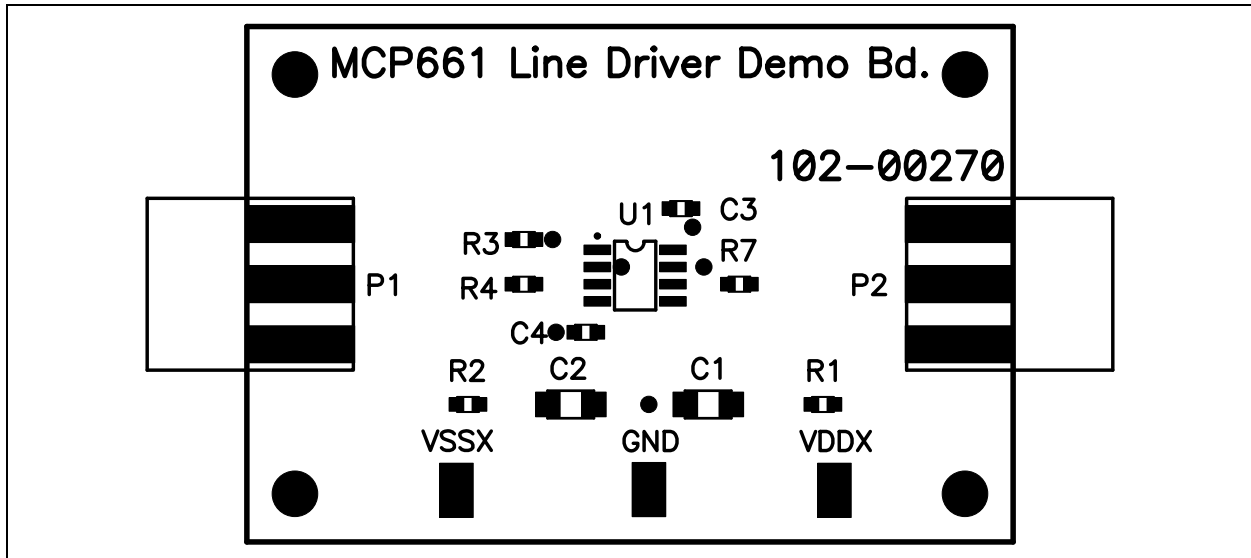

MCP661 Line Driver Demo Board User's Guide

A.5 BOARD – BOTTOM METAL LAYER (TOP VIEW)

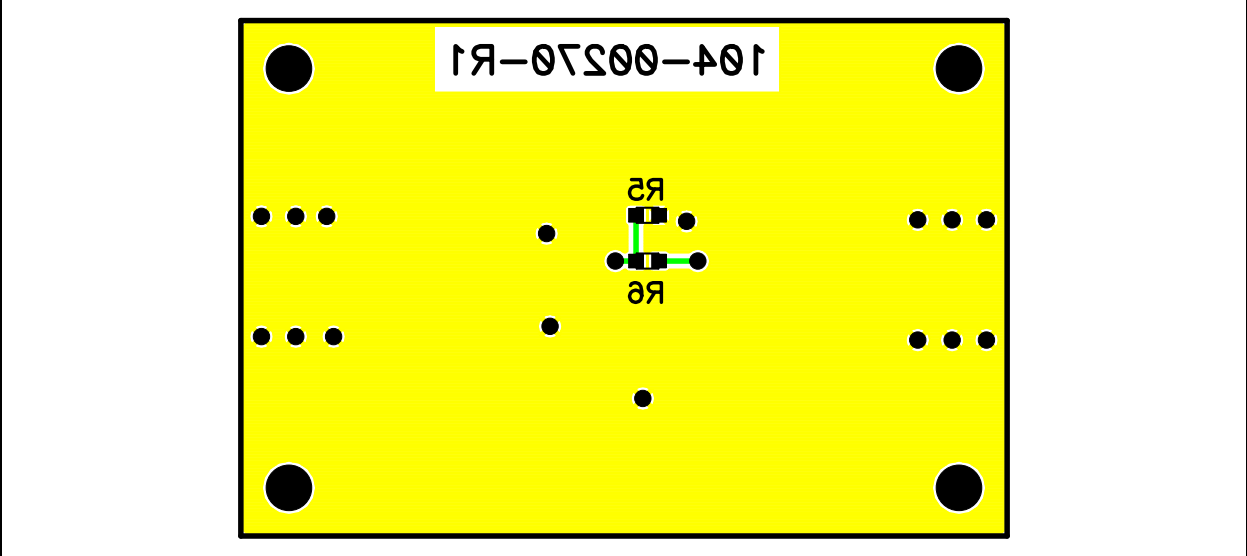

A.6 BOARD – BOTTOM METAL LAYER (BOTTOM VIEW)

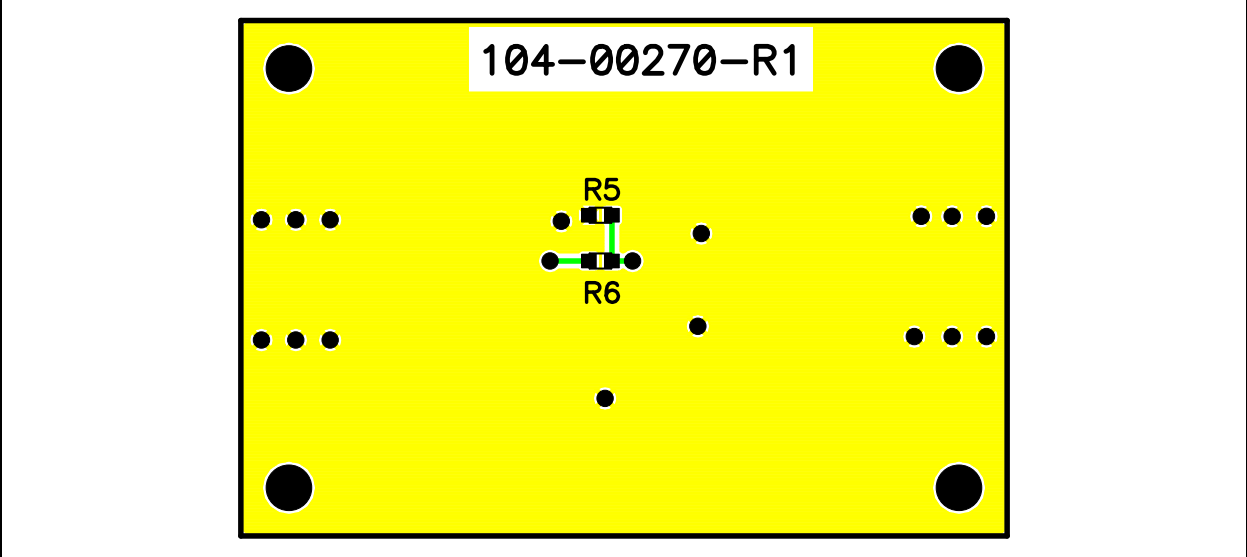

Appendix B. Bill Of Materials (BOM)

B.1 MCP661 LINE DRIVER DEMO BOARD BOM

The BOM in Table B-1 shows all of the components assembled on the PCB. Table B-2 shows alternate components that can be placed on this PCB (after modification).

TABLE B-1: BILL OF MATERIALS FOR ASSEMBLED PCB

Qty.	Reference Designator	Description	Manufacturer	Part Number
2	C3, C4	100 nF, 0603 SMD, X7R, 16V, 10%	Panasonic®-ECG	ECJ-1VB1C104K
2	C1, C2	10 µF, 1206 SMD, X7R, 16V, 10%	Panasonic-ECG	ECJ-3YX1C106K
2	P1, P2	BNC Recepticle, 50Ω, Top Mount (1)	Amphenol	031-5329-52RFX
2	R3, R7	49.9Ω, 0603 SMD, 1%, 1/10W	Yageo®	RC0603FR-0749R9L
1	R4	124Ω, 0603 SMD, 1%, 1/10W	Yageo	RC0603FR-07124RL
2	R5, R6	301Ω, 0603 SMD, 1%, 1/10W	Yageo	RC0603FR-07301RL
2	R1, R2	1.0Ω, 0603 SMD, 5%, 1/10W	Yageo	RC0603JR-071RL
3	TP1 – TP3	SMD, Test Point	Keystone Electronics®	5016
1	U1	MCP661, SOIC-8, Single Op Amp	Microchip Technology Inc.	MCP661-E/SN
1	PCB	2 layer PCB (2.23 in x 1.50 in)	Microchip Technology Inc.	102-00270
4	(for PCB mounting)	Hemispherical Bumpon Standoff, 0.44 in x 0.20 in	3M	SJ-5003 (BLACK)

Note 1: These are mounted on the side to reduce strain on the cables in the lab.

2: The components listed in this Bill of Materials are representative of the PCB assembly. The released BOM used in manufacturing uses all RoHS-compliant components.

TABLE B-2: BILL OF MATERIALS FOR ALTERNATE COMPONENTS

Qty.	Reference Designator	Description	Manufacturer	Part Number
0	(for PCB mounting)	Stand-off, Hex, 0.500", 4 x 40 Thread, Nylon, 0.285" max. O.D.	Keystone Electronics	1902C
0	(for PCB mounting)	Machine Screw, Phillips, 4 x 40 Thread, 1/4" long, Nylon	Building Fasteners	NY PMS 440 0025 PH

Note 1: The components listed in this Bill of Materials are representative of the PCB assembly. The released BOM used in manufacturing uses all RoHS-compliant components.



WORLDWIDE SALES AND SERVICE

AMERICAS

Corporate Office

2355 West Chandler Blvd.
Chandler, AZ 85224-6199
Tel: 480-792-7200
Fax: 480-792-7277
Technical Support:
<http://support.microchip.com>
Web Address:
www.microchip.com

Atlanta

Duluth, GA
Tel: 678-957-9614
Fax: 678-957-1455

Boston

Westborough, MA
Tel: 774-760-0087
Fax: 774-760-0088

Chicago

Itasca, IL
Tel: 630-285-0071
Fax: 630-285-0075

Cleveland

Independence, OH
Tel: 216-447-0464
Fax: 216-447-0643

Dallas

Addison, TX
Tel: 972-818-7423
Fax: 972-818-2924

Detroit

Farmington Hills, MI
Tel: 248-538-2250
Fax: 248-538-2260

Kokomo

Kokomo, IN
Tel: 765-864-8360
Fax: 765-864-8387

Los Angeles

Mission Viejo, CA
Tel: 949-462-9523
Fax: 949-462-9608

Santa Clara

Santa Clara, CA
Tel: 408-961-6444
Fax: 408-961-6445

Toronto

Mississauga, Ontario,
Canada
Tel: 905-673-0699
Fax: 905-673-6509

ASIA/PACIFIC

Asia Pacific Office

Suites 3707-14, 37th Floor
Tower 6, The Gateway
Harbour City, Kowloon
Hong Kong
Tel: 852-2401-1200
Fax: 852-2401-3431

Australia - Sydney

Tel: 61-2-9868-6733
Fax: 61-2-9868-6755

China - Beijing

Tel: 86-10-8528-2100
Fax: 86-10-8528-2104

China - Chengdu

Tel: 86-28-8665-5511
Fax: 86-28-8665-7889

China - Hong Kong SAR

Tel: 852-2401-1200
Fax: 852-2401-3431

China - Nanjing

Tel: 86-25-8473-2460
Fax: 86-25-8473-2470

China - Qingdao

Tel: 86-532-8502-7355
Fax: 86-532-8502-7205

China - Shanghai

Tel: 86-21-5407-5533
Fax: 86-21-5407-5066

China - Shenyang

Tel: 86-24-2334-2829
Fax: 86-24-2334-2393

China - Shenzhen

Tel: 86-755-8203-2660
Fax: 86-755-8203-1760

China - Wuhan

Tel: 86-27-5980-5300
Fax: 86-27-5980-5118

China - Xiamen

Tel: 86-592-2388138
Fax: 86-592-2388130

China - Xian

Tel: 86-29-8833-7252
Fax: 86-29-8833-7256

China - Zhuhai

Tel: 86-756-3210040
Fax: 86-756-3210049

ASIA/PACIFIC

India - Bangalore

Tel: 91-80-3090-4444
Fax: 91-80-3090-4080

India - New Delhi

Tel: 91-11-4160-8631
Fax: 91-11-4160-8632

India - Pune

Tel: 91-20-2566-1512
Fax: 91-20-2566-1513

Japan - Yokohama

Tel: 81-45-471- 6166
Fax: 81-45-471-6122

Korea - Daegu

Tel: 82-53-744-4301
Fax: 82-53-744-4302

Korea - Seoul

Tel: 82-2-554-7200
Fax: 82-2-558-5932 or
82-2-558-5934

Malaysia - Kuala Lumpur

Tel: 60-3-6201-9857
Fax: 60-3-6201-9859

Malaysia - Penang

Tel: 60-4-227-8870
Fax: 60-4-227-4068

Philippines - Manila

Tel: 63-2-634-9065
Fax: 63-2-634-9069

Singapore

Tel: 65-6334-8870
Fax: 65-6334-8850

Taiwan - Hsin Chu

Tel: 886-3-6578-300
Fax: 886-3-6578-370

Taiwan - Kaohsiung

Tel: 886-7-536-4818
Fax: 886-7-536-4803

Taiwan - Taipei

Tel: 886-2-2500-6610
Fax: 886-2-2508-0102

Thailand - Bangkok

Tel: 66-2-694-1351
Fax: 66-2-694-1350

EUROPE

Austria - Wels

Tel: 43-7242-2244-39
Fax: 43-7242-2244-393

Denmark - Copenhagen

Tel: 45-4450-2828
Fax: 45-4485-2829

France - Paris

Tel: 33-1-69-53-63-20
Fax: 33-1-69-30-90-79

Germany - Munich

Tel: 49-89-627-144-0
Fax: 49-89-627-144-44

Italy - Milan

Tel: 39-0331-742611
Fax: 39-0331-466781

Netherlands - Drunen

Tel: 31-416-690399
Fax: 31-416-690340

Spain - Madrid

Tel: 34-91-708-08-90
Fax: 34-91-708-08-91

UK - Wokingham

Tel: 44-118-921-5869
Fax: 44-118-921-5820

03/26/09



Компания «ЭлектроПласт» предлагает заключение долгосрочных отношений при поставках импортных электронных компонентов на взаимовыгодных условиях!

Наши преимущества:

- Оперативные поставки широкого спектра электронных компонентов отечественного и импортного производства напрямую от производителей и с крупнейших мировых складов;
- Поставка более 17-ти миллионов наименований электронных компонентов;
- Поставка сложных, дефицитных, либо снятых с производства позиций;
- Оперативные сроки поставки под заказ (от 5 рабочих дней);
- Экспресс доставка в любую точку России;
- Техническая поддержка проекта, помощь в подборе аналогов, поставка прототипов;
- Система менеджмента качества сертифицирована по Международному стандарту ISO 9001;
- Лицензия ФСБ на осуществление работ с использованием сведений, составляющих государственную тайну;
- Поставка специализированных компонентов (Xilinx, Altera, Analog Devices, Intersil, Interpoint, Microsemi, Aeroflex, Peregrine, Syfer, Eurofarad, Texas Instrument, Miteq, Cobham, E2V, MA-COM, Hittite, Mini-Circuits, General Dynamics и др.);

Помимо этого, одним из направлений компании «ЭлектроПласт» является направление «Источники питания». Мы предлагаем Вам помощь Конструкторского отдела:

- Подбор оптимального решения, техническое обоснование при выборе компонента;
- Подбор аналогов;
- Консультации по применению компонента;
- Поставка образцов и прототипов;
- Техническая поддержка проекта;
- Защита от снятия компонента с производства.



Как с нами связаться

Телефон: 8 (812) 309 58 32 (многоканальный)

Факс: 8 (812) 320-02-42

Электронная почта: org@eplast1.ru

Адрес: 198099, г. Санкт-Петербург, ул. Калинина, дом 2, корпус 4, литера А.