

Keywords: Fremont (MAXREFDES6#), subsystem reference design, analog front-end (AFE)

SUBSYSTEM BOARD 5721

Fremont (MAXREFDES6#): 16-Bit, High-Accuracy, 0 to 100mV Input, Isolated Analog Front-End (AFE)

Sep 19, 2013

Abstract: The Fremont (MAXREFDES6#) subsystem reference design meets the high-resolution needs of low-voltage output sensor applications. Boards for purchase, hardware and firmware design files, and FFTs and histograms from lab measurements provide complete system information for rapid prototyping and development.

Introduction

Smart factories, industrial, and medical applications continue to utilize more sensors, of various configurations. While low-voltage sensors provide essential data, they also require/generate high signal-to-noise ratios, rendering many discrete and integrated analog-to-digital converters (ADCs) insufficient for these applications.

[More detailed image \(JPG\)](#)

The compact Fremont ([MAXREFDES6#](#)) subsystem reference design (**Figure 1**) accurately measures low voltage, 0 to 100mV, single-ended analog signals with a high-accuracy, 16-bit analog front end (AFE) complete with an isolated data path. The design optimizes the functions of an ultra-precision low-noise buffer ([MAX9632](#)); a highly accurate ADC ([MAX11100](#)); an ultra-high-precision 4.096V voltage reference ([MAX6126](#)); a 600VRMS monolithic data isolator ([MAX14850](#)); and low-dropout (LDO) regulators providing regulated +6V, +5V, and -5V power rails ([MAX1659](#) and [MAX1735](#)). This oneofakind AFE solution works in many applications requiring low-voltage input, high impedance, and high-accuracy analog-to-digital conversion.

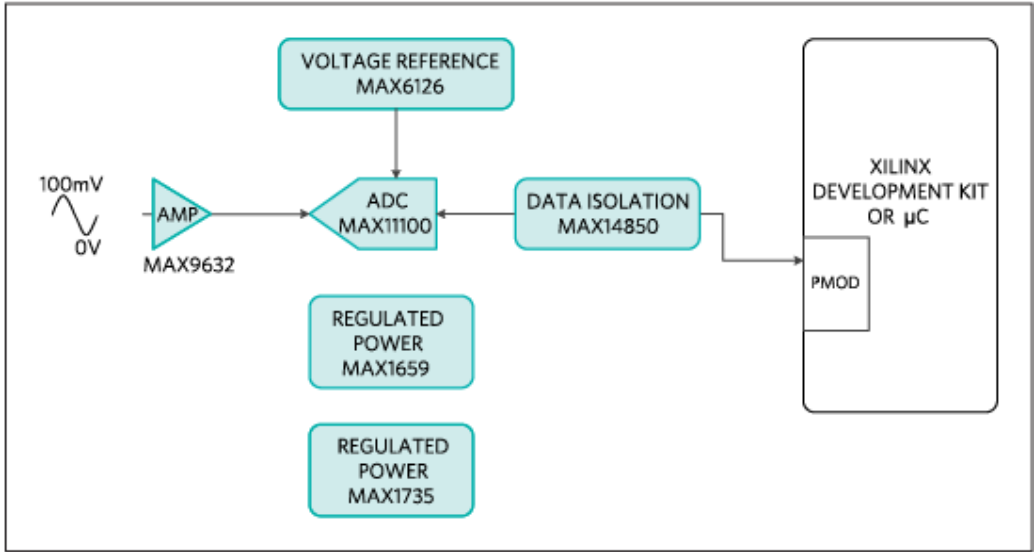

Figure 1. The Fremont subsystem design block diagram.

Features

- High-accuracy analog input
- High impedance
- 0 to 100mV input range
- Isolated data path
- Small printed-circuit board (PCB) area
- Device drivers
- Example C source code
- Pmod™-compatible form factor

Applications

- Low-voltage output sensors
- Process control
- Medical

Competitive Advantages

- Unique single-ended architecture
- Optimized board size
- Magnetically immune data path isolation

Detailed Description of Hardware

Fremont interfaces with field-programmable gate array (FPGA) development boards using a Pmod connector. The Pmod specification allows for both 3.3V and 5V modules as well as various pin assignments. Fremont requires a 3.3V supply voltage and uses the SPI pin assignments as illustrated here.

Table 1 shows the power requirements. **Table 2** shows the supported platforms and ports.

Power Type	Input	Input Voltage (V)	Input Current (mA, typ)
External power	EXT_V+	7	22
	EXT_V-	-6	20

Supported Platforms	Ports
Nexys™ 3 platform (Spartan®-6)	JB1
ZedBoard™ platform (Zynq®-7020)	JA1

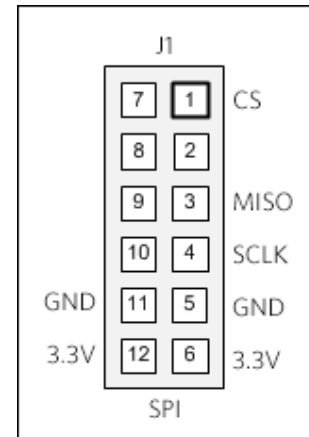

The MAX9632 (U1) op amp input circuit amplifies and buffers a 0 to 100mV signal to match the input range of the ADC (MAX11100), which is 0 to 4.096V.

The MAX11100 (U2) is a 16-bit, successive-approximation register (SAR) ADC with AutoShutdown™ and fast 1.1µs wake-up features. The ADC's reference input is driven by an ultra-high-precision 4.096V voltage reference, the MAX6126 (U3), with 0.02% initial accuracy and a 3ppm/°C maximum temperature coefficient (tempco).

The Fremont hardware design provides isolated data (MAX14850) for a high-accuracy, high-impedance, 0 to 100mV signal, analog-to-digital conversion application.

External power supplies power the Fremont board prior to voltage regulation. The MAX1659 LDO regulator provides +6V and +5V rails and the MAX1735 LDO regulator provides the -5V rail. The MAX14850 (U5) isolates the digital data up to 600V.

To power the Fremont board, connect the ground terminal of the external power supplies to the GND2 connector. Connect the +7V to +16.5V supply to the EXT_V+ connector, and the -6V supply to the EXT_V- connector.

Detailed Description of Firmware for Nexys 3 Platform

Table 2 shows currently supported platforms and ports. Support for additional platforms may be added periodically under Firmware Files in the All Design Files section below.

The Fremont firmware released for the Nexys 3 development kit targets a Microblaze™ soft-core microcontroller placed inside a Xilinx® Spartan-6 FPGA.

The firmware allows for immediate interfacing to the hardware, and for collection and saving of samples. **Figure 2a** shows the simple process flow. The firmware is in C, developed using the Xilinx software development kit (SDK) tool, based on the Eclipse™ open source standard. Custom Fremont-specific design functions (driver in the maximDeviceSpecificUtilities.c file) were created utilizing the standard Xilinx XSpi core version 3.03a. The SPI clock frequency is set to 3.125MHz.

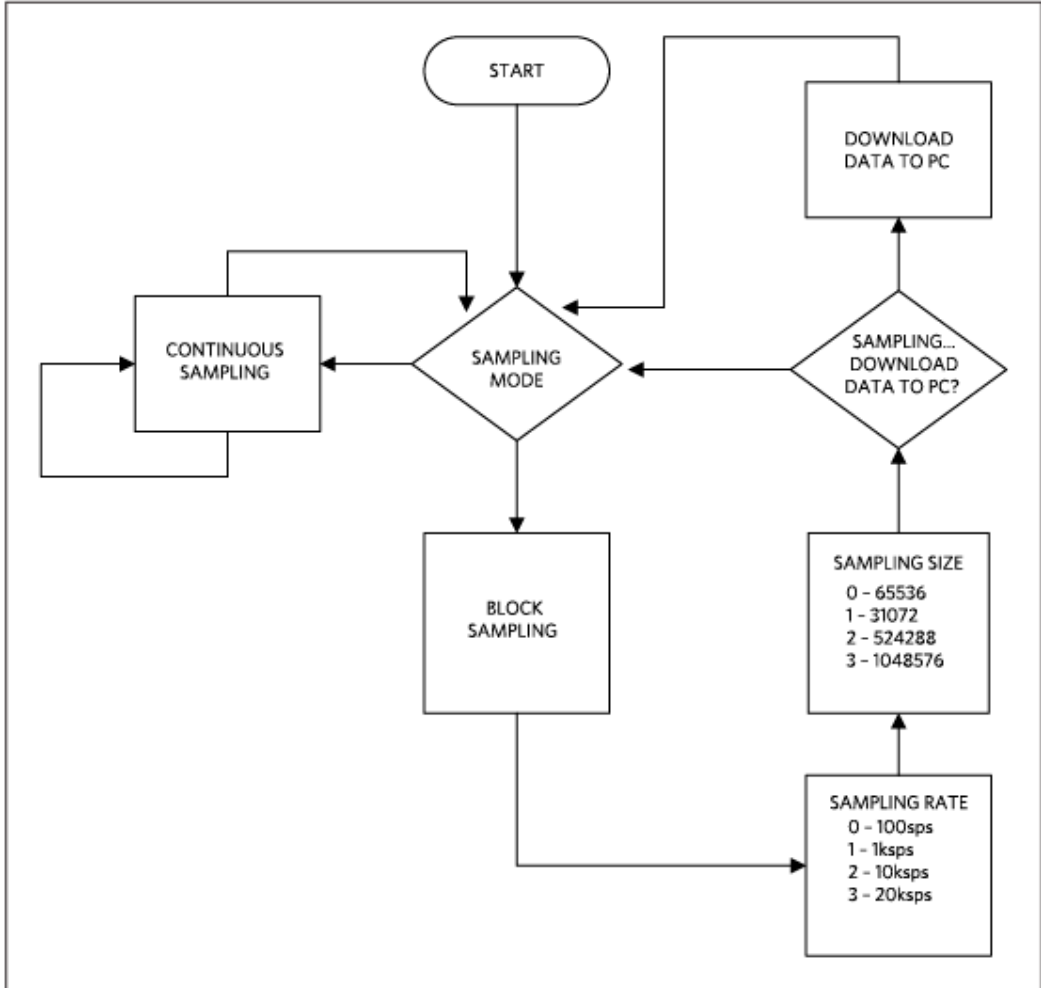

Figure 2a. The Fremont firmware flowchart for Nexys 3 platform.

The firmware accepts commands, writes status, and can download blocks of sampled data to a standard terminal program over a virtual COM port. The complete source code speeds customer development. Code documentation resides in the corresponding firmware platform files.

Detailed Description of Firmware for ZedBoard Platform

The Fremont firmware design also supports the ZedBoard kit and targets an ARM® Cortex® -A9 processor placed inside a Xilinx Zynq system-on-chip (SoC).

The firmware features an AXI MAX11100 custom IP core to optimize the sampling rate and SPI timing stability.

The firmware allows for immediate interfacing to the hardware, for collection and saving of samples. **Figure 2b** shows the simple process flow. The firmware is in C, developed using the Xilinx SDK tool, based on the Eclipse™ open source standard. Custom Fremont-specific design functions (driver in the `maximDeviceSpecificUtilities.c` file) were created utilizing the AXI MAX11100 custom IP core. The SPI clock frequency is 4.54MHz when the sample rate is 189.4ksps. The SPI clock frequency is set to 2.5MHz for all other sampling rate.

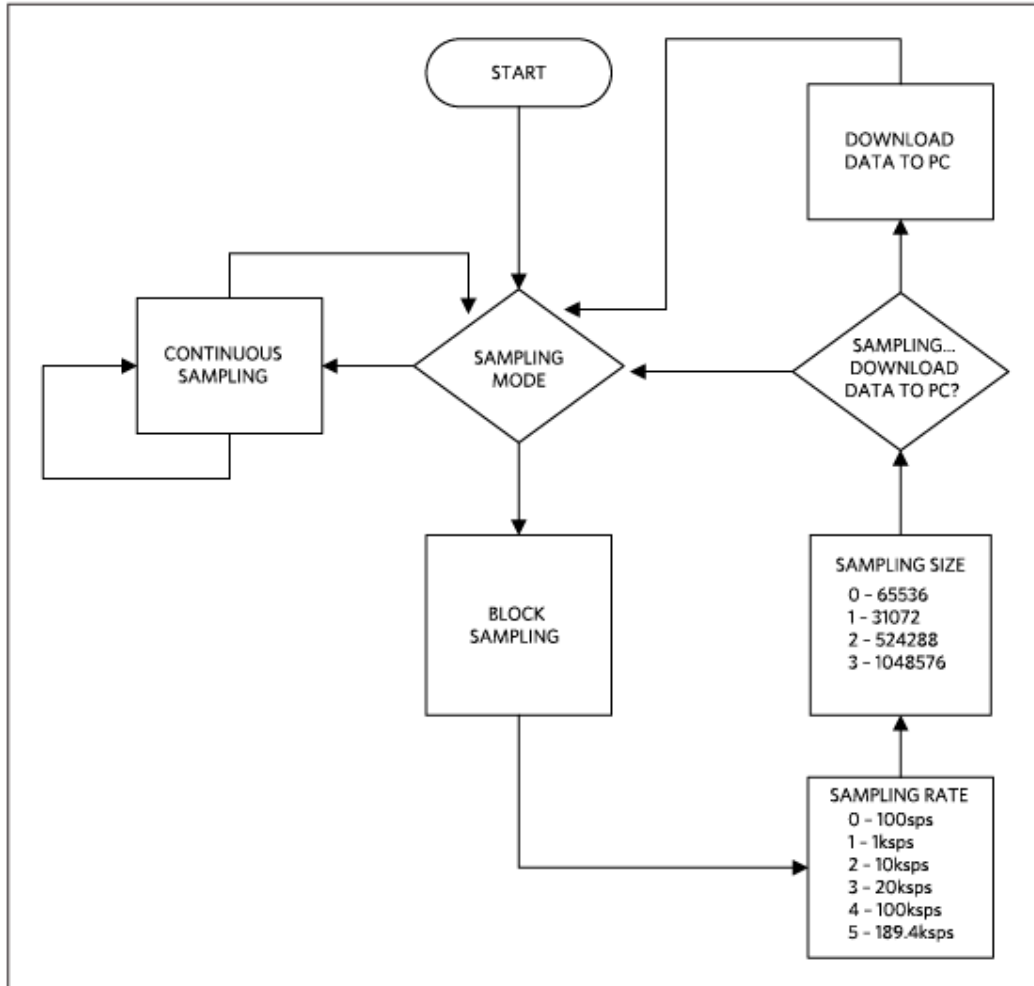

Figure 2b. The Fremont firmware flowchart ZedBoard platform.

The firmware accepts commands, writes status, and can download blocks of sampled data to a standard terminal program over a virtual COM port. The complete source code speeds customer development. Code documentation resides in the corresponding firmware platform files.

Quick Start

Required equipment:

- Windows® PC with two USB ports
- Fremont (MAXREFDES6#) board
- Fremont-supported platform (i.e., Nexys 3 development kit or ZedBoard kit)

Industrial sensor or signal source

Download, read, and carefully follow each step in the appropriate Fremont Quick Start Guide:

[Fremont \(MAXREFDES6#\) Nexys 3 Quick Start Guide](#)

[Fremont \(MAXREFDES6#\) ZedBoard Quick Start Guide](#)

Lab Measurements

Equipment:

- HP 33120A waveform generator
- Voltage calibrator DVC-8500
- Windows PC with two USB ports
- Fremont (MAXREFDES6#) board
- Nexys 3 development kit
- +7V power supply
- -6V power supply

Take special care and use proper equipment when testing the Fremont design. Any high-accuracy design requires sources and measurement equipment of higher accuracy than the design under test. Duplication of the presented test data requires a low distortion signal source. A HP 33120A function generator produced the input signal, and the FFTs were created using the FFT control in SignalLab from [Mitov Software](#).

Figure 3 and **Figure 4** show AC and DC performance.

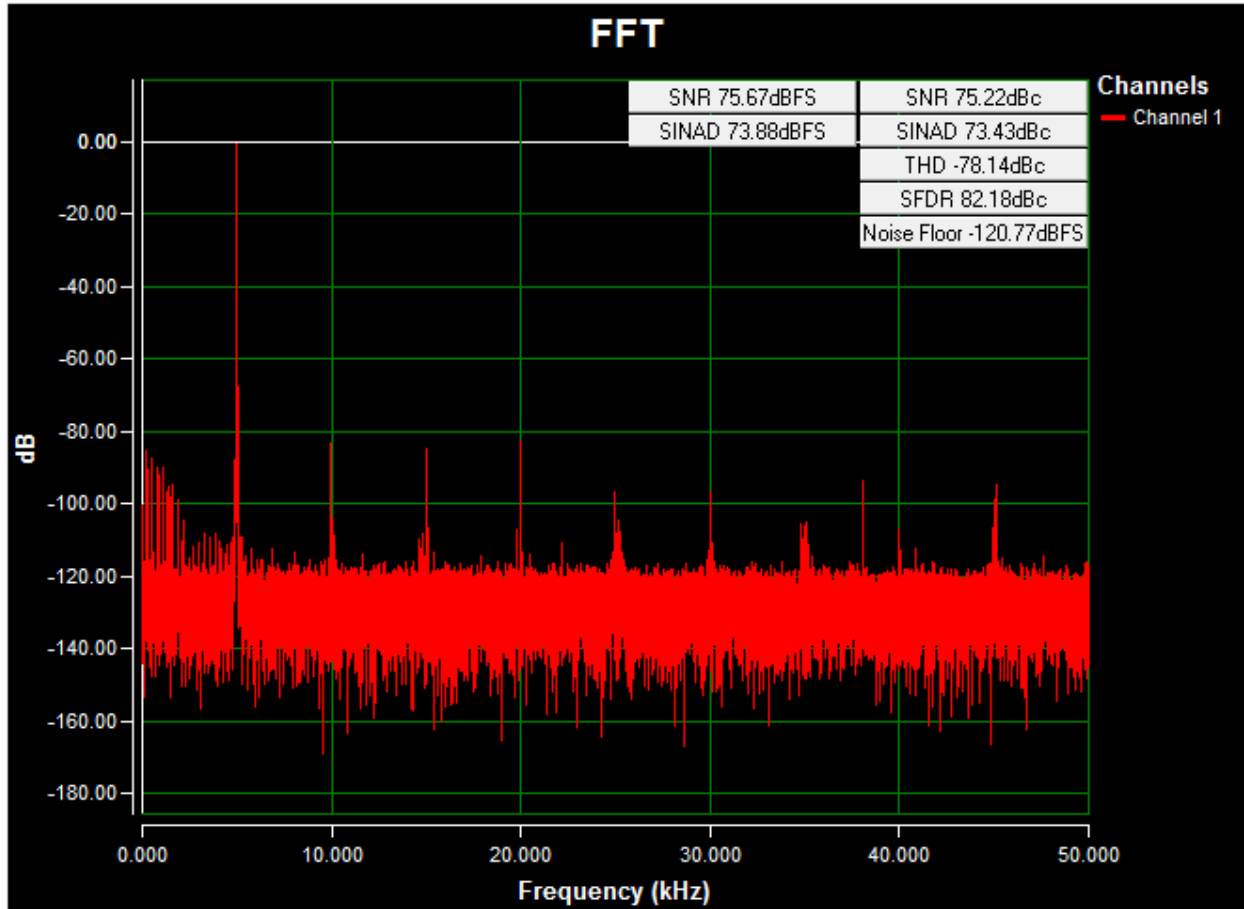

Figure 3. AC FFT using on-board isolated power, a 0 to 100mV, 1kHz sine-wave input signal, high-impedance input, a 20ksps sample rate, and a Blackman-Harris window.

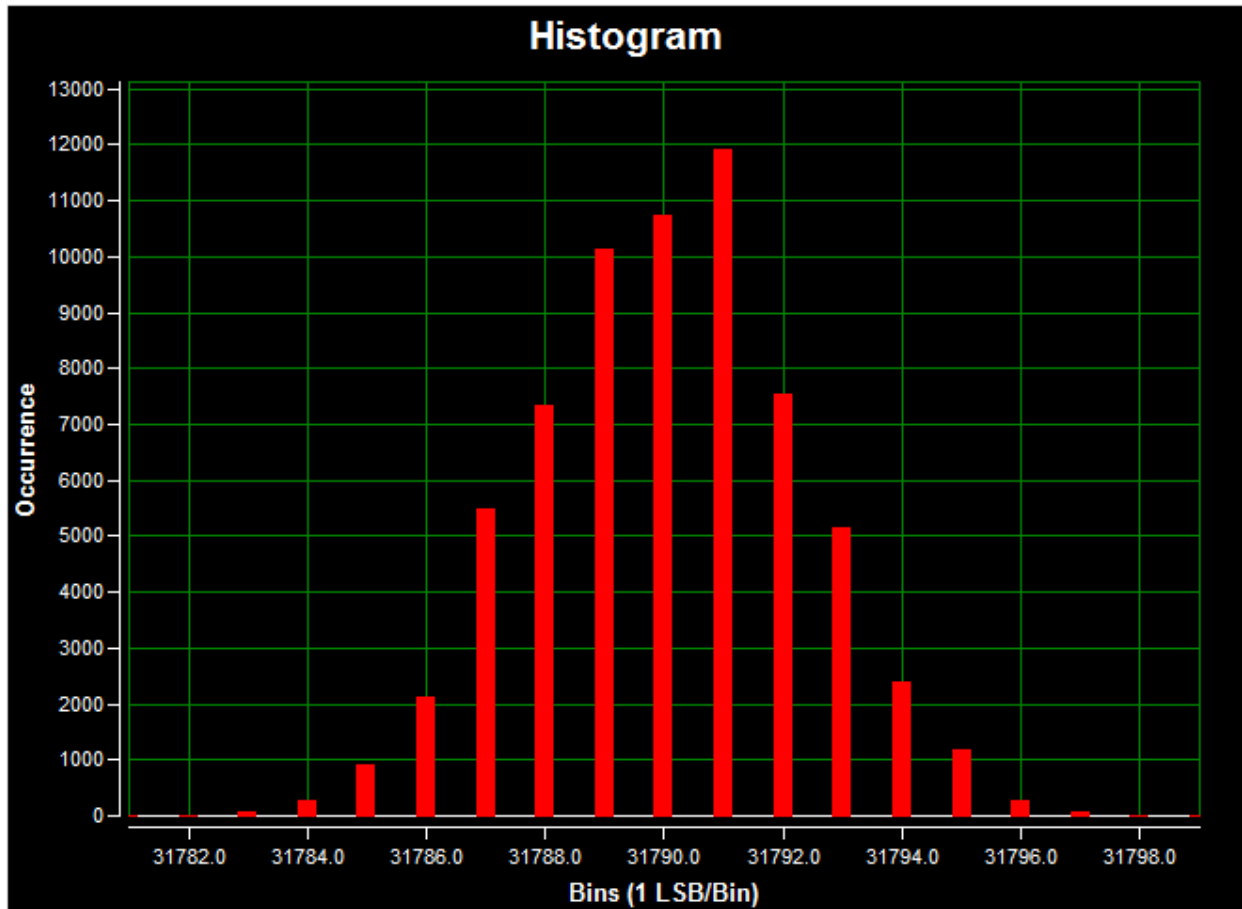

Figure 4. DC histogram using on-board isolated power; a 50mV input signal; a 20ksps sample rate; 65,536 samples; a code spread of 19 LSBs with 95.7% of the codes falling within the nine center LSBs; and a standard deviation of 2.236.

All Design Files

[Download All Design Files](#)

Hardware Files

- [Schematic](#)
- [Bill of materials \(BOM\)](#)
- [PCB layout](#)
- [PCB Gerber](#)
- [PCB CAD \(PADS 9.0\)](#)

Firmware Files

- [Nexys 3 Platform](#)
- [ZedBoard Platform \(Zynq-7000\)](#)

Buy Reference Design

Buy Direct: [Fremont \(MAXREFDES6#\)](#)

Or

Order the Fremont reference design (MAXREFDES6#) from your local Maxim representative.

ARM is a registered trademark and registered service mark of ARM Limited.

AutoShutdown is a trademark of Maxim Integrated Products, Inc.

Cortex is a registered trademark of ARM Limited.

Eclipse is a trademark of Eclipse Foundation, Inc.

MicroBlaze is a trademark of Xilinx, Inc.

Nexys is a trademark of Digilent Inc.

Pmod is a trademark of Digilent Inc.

Spartan is a registered trademark of Xilinx, Inc.

Windows is a registered trademark and registered service mark of Microsoft Corporation.

Xilinx is a registered trademark and registered service mark of Xilinx, Inc.

ZedBoard is a trademark of ZedBoard.org.

Zynq is a registered trademark of Xilinx, Inc.

Related Parts

MAX11100	16-Bit, +5V, 200ksps ADC with 10µA Shutdown	Free Samples
MAX14850	Six-Channel Digital Isolator	
MAX1659	350mA, 16.5V Input, Low-Dropout Linear Regulators	Free Samples
MAX1735	200mA, Negative-Output, Low-Dropout Linear Regulator in SOT23	Free Samples
MAX6126	Ultra-High-Precision, Ultra-Low-Noise, Series Voltage Reference	Free Samples
MAX9632	36V, Precision, Low-Noise, Wide-Band Amplifier	Free Samples
MAXREFDES6	Fremont (MAXREFDES6#): 16-Bit, High-Accuracy, 0 to 100mV Input, Isolated Analog Front-End (AFE)	

More Information

For Technical Support: <http://www.maximintegrated.com/support>

For Samples: <http://www.maximintegrated.com/samples>

Other Questions and Comments: <http://www.maximintegrated.com/contact>

Application Note 5721: <http://www.maximintegrated.com/an5721>

SUBSYSTEM BOARD 5721, AN5721, AN 5721, APP5721, Appnote5721, Appnote 5721

© 2013 Maxim Integrated Products, Inc.

Additional Legal Notices: <http://www.maximintegrated.com/legal>



Компания «ЭлектроПласт» предлагает заключение долгосрочных отношений при поставках импортных электронных компонентов на взаимовыгодных условиях!

Наши преимущества:

- Оперативные поставки широкого спектра электронных компонентов отечественного и импортного производства напрямую от производителей и с крупнейших мировых складов;
- Поставка более 17-ти миллионов наименований электронных компонентов;
- Поставка сложных, дефицитных, либо снятых с производства позиций;
- Оперативные сроки поставки под заказ (от 5 рабочих дней);
- Экспресс доставка в любую точку России;
- Техническая поддержка проекта, помощь в подборе аналогов, поставка прототипов;
- Система менеджмента качества сертифицирована по Международному стандарту ISO 9001;
- Лицензия ФСБ на осуществление работ с использованием сведений, составляющих государственную тайну;
- Поставка специализированных компонентов (Xilinx, Altera, Analog Devices, Intersil, Interpoint, Microsemi, Aeroflex, Peregrine, Syfer, Eurofarad, Texas Instrument, Miteq, Cobham, E2V, MA-COM, Hittite, Mini-Circuits, General Dynamics и др.);

Помимо этого, одним из направлений компании «ЭлектроПласт» является направление «Источники питания». Мы предлагаем Вам помощь Конструкторского отдела:

- Подбор оптимального решения, техническое обоснование при выборе компонента;
- Подбор аналогов;
- Консультации по применению компонента;
- Поставка образцов и прототипов;
- Техническая поддержка проекта;
- Защита от снятия компонента с производства.



Как с нами связаться

Телефон: 8 (812) 309 58 32 (многоканальный)

Факс: 8 (812) 320-02-42

Электронная почта: org@eplast1.ru

Адрес: 198099, г. Санкт-Петербург, ул. Калинина, дом 2, корпус 4, литера А.