

DA12-M Series

12 Watts

Total Power: 12 Watts
Input Voltage: 90 - 264 Vac
of Outputs: Single

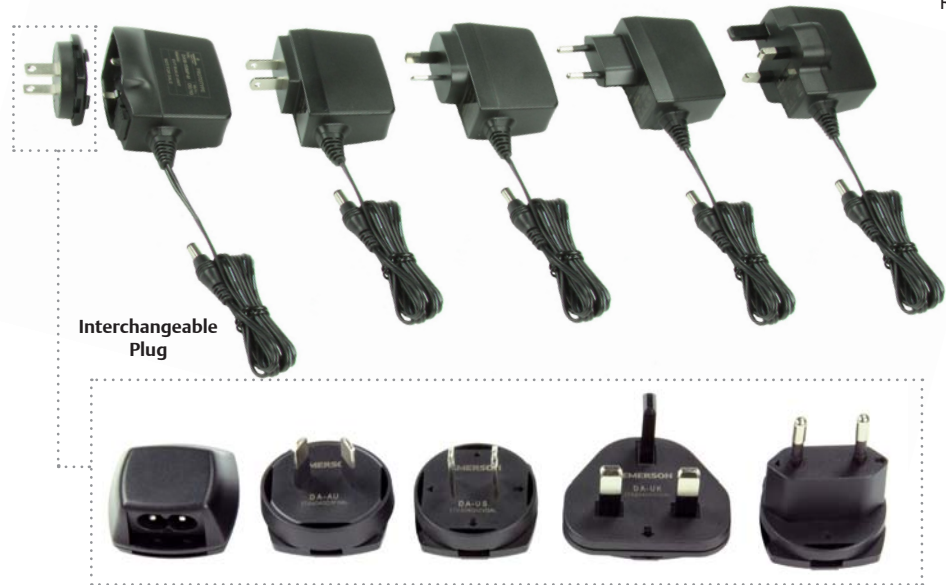

Special Features

- 5 V and 12 V versions
- Medical and ITE Safeties
- Switching wallmount power supply
- Available in interchangeable & fixed ac plug configurations
- CE Mark EMC, LVD & ErP 2011
- Universal AC input
- Fully regulated output
- Overload and short circuit protection
- Thermal protection
- Energy Star and CeC compliant
- Efficiency level V
- Constant voltage
- High MTBF
- Built in EMI filter (CISPR 22 Class B)

Safety

- **UL** 60950, 60601-1
- **cUL** 60950, 60601-1
- **TUV** 60950-1, 60601-1
- **AS/NZS** 60950-1, 60601-1
- **CB** Certificate and report
- **CE** EMC, LVD & ErP 2011 for EU & UK versions
- **PSE** Denan (US only)

Electrical Specifications

Input	
Input range:	90 - 264 Vac (wide range)
Frequency:	47 - 63 Hz
Inrush current:	28 A @ 264 Vac
Input current:	0.25 A rms @ 120 Vac; 0.15 A @ 240 Vac
EMI/RFI:	FCC Part 15, Subpart B Class B & EN55022 (CISPR 22) Class B
Safety ground leakage current:	100 μ A @ 50/60 Hz, 264 Vac input
Output	
Voltage (Vo):	5.0 V and 12.0 V
Voltage regulation:	\pm 5% @ constant voltage mode
Maximum Power (Po):	12 W for 12 V models, 10 W for 5 V models
Hold-up time:	10 ms. typical at full load @ 230 Vac
Overvoltage protection:	Non-latching type
Overload protection:	Output shortcircuit protection auto recover Overload protected @ 150% above maximum rating
Overtemperature protection:	Auto recovery
Output cable/connector barrel polarity:	DC cable with 2.5 mm x 5.5mm barrel plug, 2.1 mm x 5.5 mm available on DC multi-plug version. For others please contact factory. DC plug center +v DC plug outer -v

Environmental Specifications

Operating temperature:	0 ° to +40 °C ambient		
Storage temperature:	-40 °C to +85 °C		
Electromagnetic susceptibility:	Designed to meet EN55024		
Humidity:	Operating; non-condensing 5% to 95% RH		
Vibration:	Frequency/PSD: 5 - 350 Hz	0.0001 g ² /Hz	
	350 - 500 Hz - 6dB/Oct.		
	500 Hz	0.00005g ² /Hz	
	Acceleration:	0.21 gRMS	
	Duration:	20 min per second	

AC Plug Configuration for Fixed Plug

U.S. 2-prong	US
Europe 2-prong	EU
United Kingdom 3-prong	UK
Australia 2-prong	AU

AC Plug Configuration for Interchangeable Plug

U.S. 2-prong	DA-US
Europe 2-prong	DA-EU
United Kingdom 3-prong	DA-UK
Australia 2-prong	DA-AU
C8 - 2 receptacle	DA-C8

Ordering Information - DA12 Adapter

Model Number	Maximum Power	Output Voltage	Minimum Load	Maximum Load	Regulation ²	Ripple P/P (PAR) ³
DA12-120US-M	12 W	12.0 V	0.2 A	1.0	± 5%	120 mV
DA12-120EU-M	12 W	12.0 V	0.2 A	1.0	± 5%	120 mV
DA12-120UK-M	12 W	12.0 V	0.2 A	1.0	± 5%	120 mV
DA12-120AU-M	12 W	12.0 V	0.2 A	1.0	± 5%	120 mV
DA12-120MP-M*	12 W	12.0 V	0.2 A	1.0	± 5%	120 mV
DA12-120MP-M2.1**	12 W	12.0 V	0.2 A	1.0	± 5%	120 mV
DA12-050US-M	10 W	5.0 V	0.2 A	2.0	± 5%	50 mV
DA12-050EU-M	10 W	5.0 V	0.2 A	2.0	± 5%	50 mV
DA12-050UK-M	10 W	5.0 V	0.2 A	2.0	± 5%	50 mV
DA12-050AU-M	10 W	5.0 V	0.2 A	2.0	± 5%	50 mV
DA12-050MP-M*	10 W	5.0 V	0.2 A	2.0	± 5%	50 mV
DA12-050MP-M2.1**	10 W	5.0 V	0.2 A	2.0	± 5%	50 mV

* Interchangeable version - AC Plugs must be purchased separately to be used with DA12-120MP-M and DA12-050MP-M

** 2.1 mm x 5.5 mm barrel plug

Ordering Information - DA12 Interchangeable Plug

Model Number	
DA-US	DA-C8
DA-EU	DA-JP
DA-UK	DA-CH
DA-AU	DA-KR
DA-All	Includes DA-US, DA-EU, DA-UK, and DA-AU

1. Peak current lasting < 30 seconds with a maximum 10% duty cycle.
2. At 25 °C including initial tolerance, line voltage, load currents and output voltages adjusted to factory settings.
3. Peak-to-peak with 20 mHz bandwidth and 10 μF in parallel with a 0.1 μF capacitor at rated line voltage and load ranges.
4. Power supplies will operate with no-load.

Mechanical Drawings

DA12-XXXUS-M

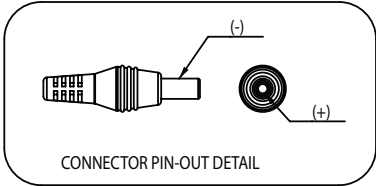
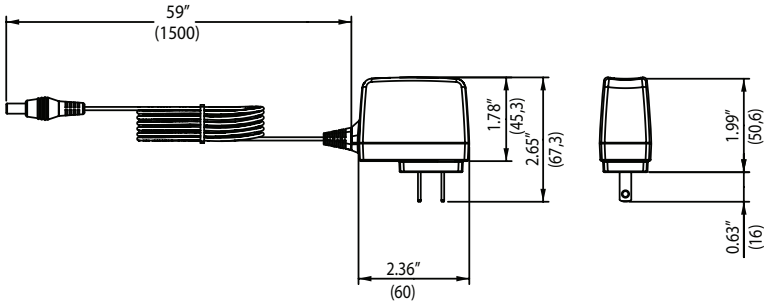

DA12-XXXAU-M

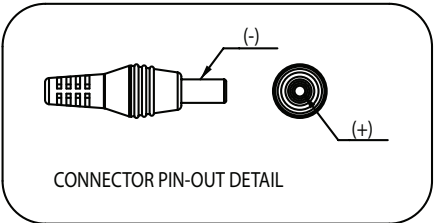
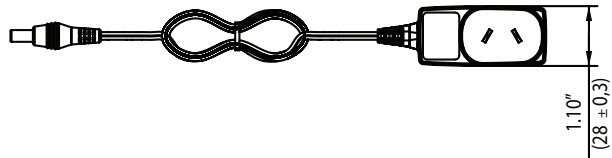
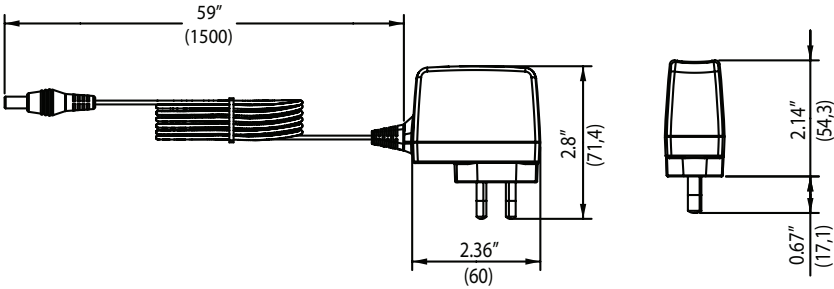

DA12-XXXEU-M

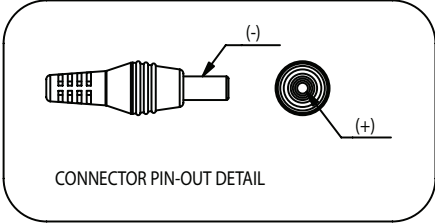
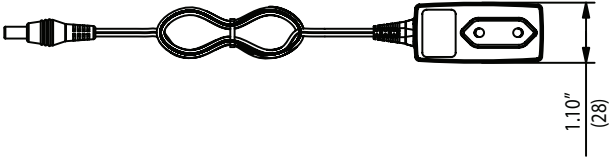
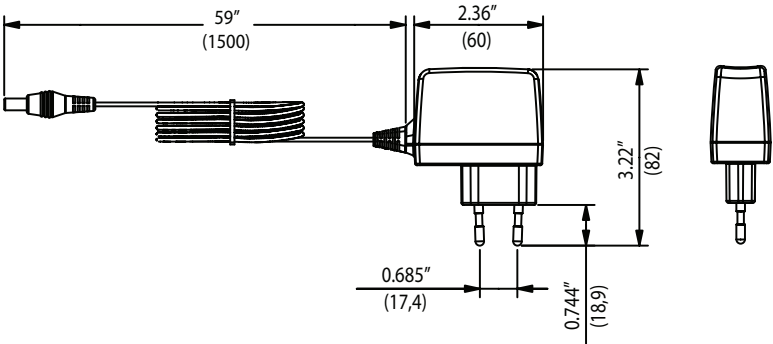

DA12-XXXUK-M

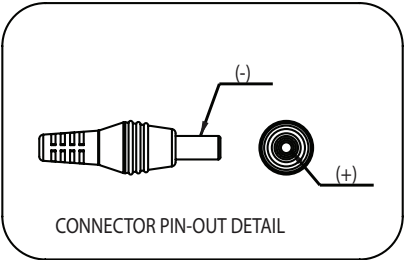
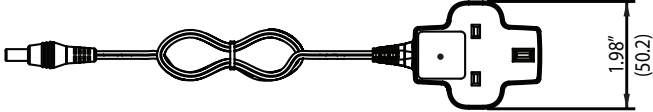
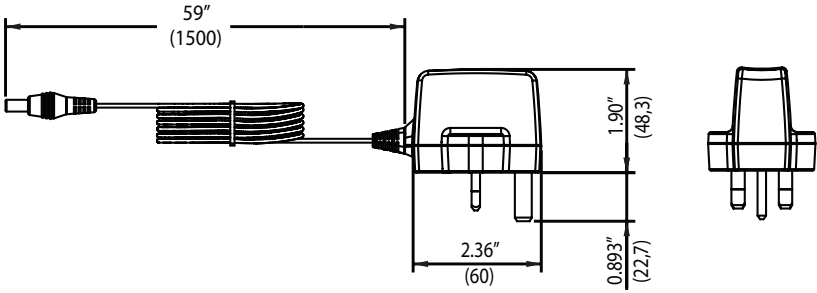

DA12-MP Interchangeable Plug Adapter

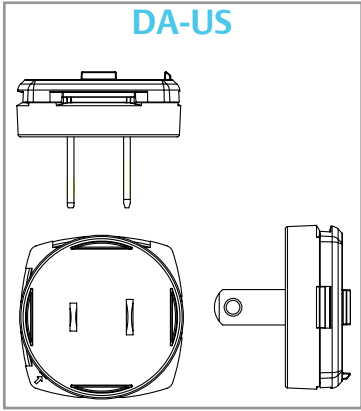
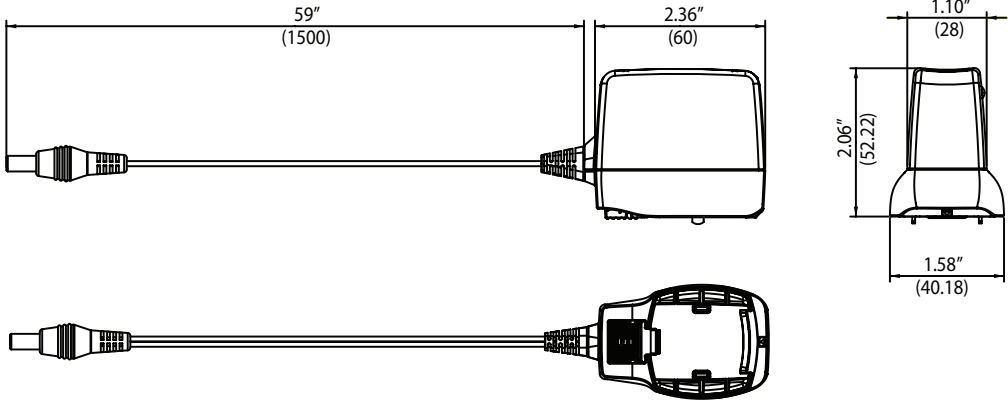

*Can be inserted straight or 90°

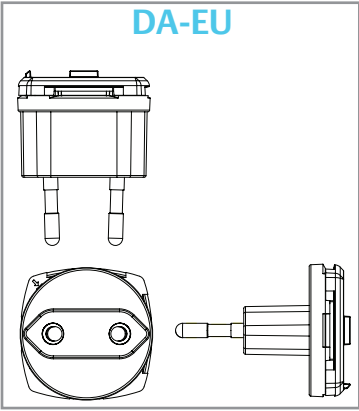
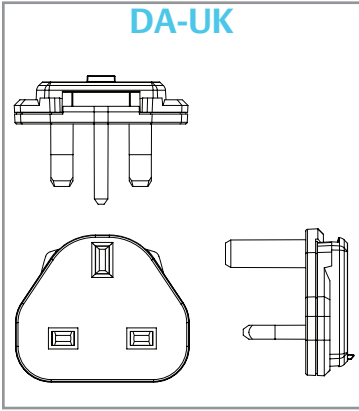

*Can be inserted straight or 90°

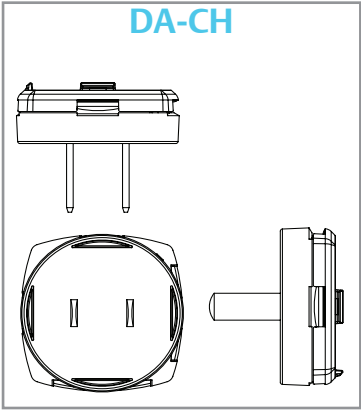
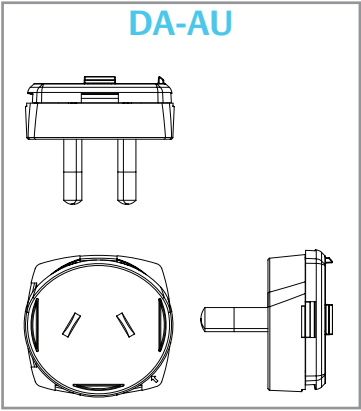

*Can be inserted straight or 90°

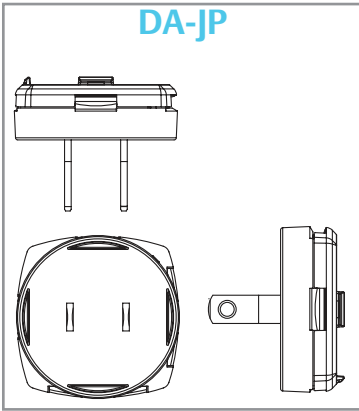

*Can be inserted straight or 90°

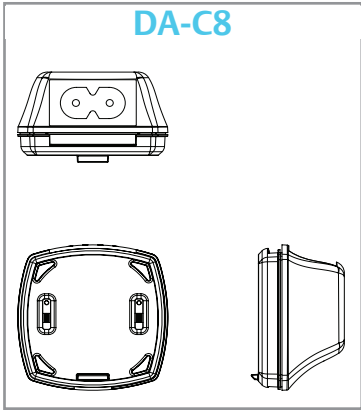
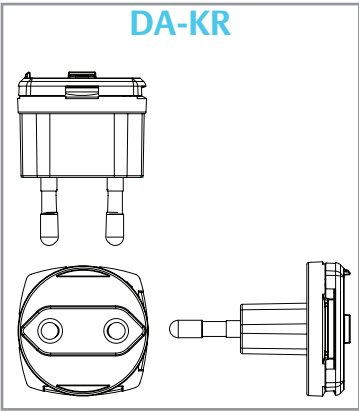

Notes:

1. Specifications subject to change without notice.
2. All dimensions in inches (mm), tolerance is ± .02".
3. Weight: 0.25 lb/0.114 kg
4. Warranty: 2 years

Americas

5810 Van Allen Way
Carlsbad, CA 92008
USA
Telephone: +1 760 930 4600
Facsimile: +1 760 930 0698

Europe (UK)

Waterfront Business Park
Merry Hill, Dudley
West Midlands, DY5 1LX
United Kingdom
Telephone: +44 (0) 1384 842 211
Facsimile: +44 (0) 1384 843 355

Asia (HK)

14/F, Lu Plaza
2 Wing Yip Street
Kwun Tong, Kowloon
Hong Kong
Telephone: +852 2176 3333
Facsimile: +852 2176 3888

For global contact, visit:

www.Emerson.com/EmbeddedPower
[techsupport.embeddedpower](mailto:techsupport.embeddedpower@emerson.com)
[@emerson.com](mailto:techsupport.embeddedpower@emerson.com)

While every precaution has been taken to ensure accuracy and completeness in this literature, Emerson Network Power assumes no responsibility, and disclaims all liability for damages resulting from use of this information or for any errors or omissions.

Emerson Network Power.
The global leader in enabling
business-critical continuity.

- AC Power
- Connectivity
- DC Power
- Embedded Computing
- **Embedded Power**
- Monitoring
- Outside Plant
- Power Switching & Controls
- Precision Cooling
- Racks & Integrated Cabinets
- Services
- Surge Protection

EmersonNetworkPower.com

Emerson Network Power and the Emerson Network Power logo are trademarks and service marks of Emerson Electric Co.
©2011 Emerson Electric Co.



Компания «ЭлектроПласт» предлагает заключение долгосрочных отношений при поставках импортных электронных компонентов на взаимовыгодных условиях!

Наши преимущества:

- Оперативные поставки широкого спектра электронных компонентов отечественного и импортного производства напрямую от производителей и с крупнейших мировых складов;
- Поставка более 17-ти миллионов наименований электронных компонентов;
- Поставка сложных, дефицитных, либо снятых с производства позиций;
- Оперативные сроки поставки под заказ (от 5 рабочих дней);
- Экспресс доставка в любую точку России;
- Техническая поддержка проекта, помощь в подборе аналогов, поставка прототипов;
- Система менеджмента качества сертифицирована по Международному стандарту ISO 9001;
- Лицензия ФСБ на осуществление работ с использованием сведений, составляющих государственную тайну;
- Поставка специализированных компонентов (Xilinx, Altera, Analog Devices, Intersil, Interpoint, Microsemi, Aeroflex, Peregrine, Syfer, Eurofarad, Texas Instrument, Miteq, Cobham, E2V, MA-COM, Hittite, Mini-Circuits, General Dynamics и др.);

Помимо этого, одним из направлений компании «ЭлектроПласт» является направление «Источники питания». Мы предлагаем Вам помощь Конструкторского отдела:

- Подбор оптимального решения, техническое обоснование при выборе компонента;
- Подбор аналогов;
- Консультации по применению компонента;
- Поставка образцов и прототипов;
- Техническая поддержка проекта;
- Защита от снятия компонента с производства.



Как с нами связаться

Телефон: 8 (812) 309 58 32 (многоканальный)

Факс: 8 (812) 320-02-42

Электронная почта: org@eplast1.ru

Адрес: 198099, г. Санкт-Петербург, ул. Калинина, дом 2, корпус 4, литера А.