

Proximity Sensor Accessories Y92E

Proximity Sensor Accessories to Mount, Protect and Optimize Sensor Efficiency

- General purpose plastic mounting brackets
- Spring mount threaded cylindrical housings in anodized aluminum and stainless steel to reduce sensor damage due to collisions
- Spring mount blocks in anodized aluminum or stainless steel
- Fast mount cylindrical tubes in nickel-plated brass and Fluoroplastic coated versions simplifies mounting and eliminates sensor positioning
- Fluoroplastic sensor caps and ceramic face discs protect sensor face from heat and abrasion
- Threaded metal block mounts
- Flat and right angle brackets in CRS or stainless steel fixed or adjustable versions
- Weld jacket for cable and cordset protection



■ General Purpose Plastic Mounting Brackets

Ordering Information

Note: Shaded models are normally stocked. Un-shaded models require 2-3 weeks delivery.

Description	Applicable sensor series	Model
Fits 3.5 mm dia. unthreaded sensor	E2C-C (Stainless Bracket)	Y92E-F3R5
Fits M5 size sensors	E2C-C (Stainless Bracket)	Y92E-F5R4
Fits M8 size sensors	E2E, E2A, E2F, E2C-T, E2C, E2C-H, E3HT	Y92E-B8
Fits M12 size sensors	E2E, E2E2, E2A, E2F, E2C, E2EC, E2K-X, E2FQ, E2EQ, E2C-H, E2EV	Y92E-B12
Fits M18 size sensors	E2E, E2E2, E2A, E2F, E2C, E2K-X, E2KQ, E2FQ, E2EQ, E2ES, E2C-H, E2EV, E2EY, E2EZ, F92A, E3F2	Y92E-B18
Fits M30 size sensors	E2E, E2E2, E2A, E2F, E2C, E2K-X, E2FQ, E2EQ, E2ES, E2EV, E2EY, E2EZ, B7AP	Y92E-B30

Dimensions

Unit: mm (inch)

Mounting Brackets

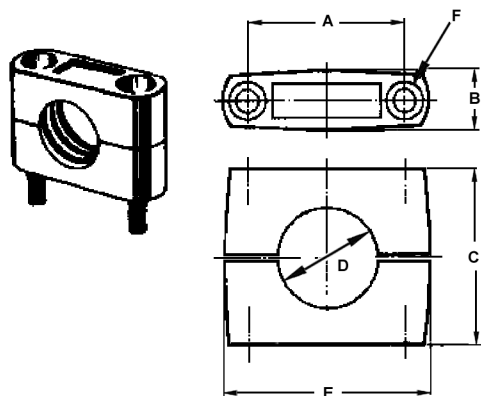

Drawing dimensions						Model
A	B max.	C	D dia.	E max.	F	
18±0.2 (0.71±0.01)	10 (0.39)	18 (0.71)	8 (0.31)	28 (1.10)	M4 x 20 bolt	Y92E-B8
24±0.2 (0.94±0.01)	12.5 (0.49)	20 (0.79)	12 (0.47)	37 (1.46)	M4 x 25 bolt	Y92E-B12
32±0.2 (1.26±0.01)	17 (0.67)	30 (1.18)	18 (0.71)	47 (1.85)	M5 x 32 bolt	Y92E-B18
45±0.2 (1.77±0.01)	17 (0.67)	50 (1.97)	30 (1.18)	60 (2.36)	M5 x 50 bolt	Y92E-B30

Y92E-F3R5

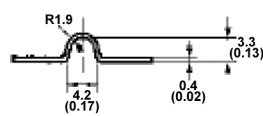

Y92E-F5R4

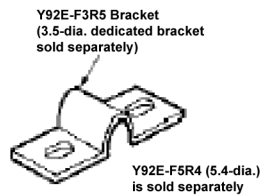
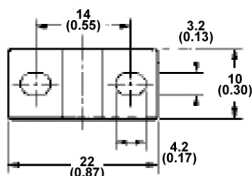
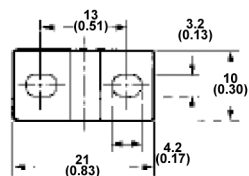
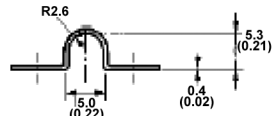

■ Replacement Mounting Hardware (2 Locknuts and 1 Washer)

Ordering Information

Note: Shaded models are normally stocked. Un-shaded models require 2-3 weeks delivery.

Description		Model
Mounting hardware including one pair of metal nuts and one washer	Fits M8 size sensors	M8-MHWS
	Fits M12 size sensors	M12-MHWS
	Fits M18 size sensors	M18-MHWS
	Fits M30 size sensors	M30-MHWS

■ Swiveling Universal Mounting Bracket

Attach threaded barrel photoelectric, ultrasonic and proximity sensors as well as limit switch-style devices having M30 threaded bases. Achieve easy flexible aiming and secure mounting with these durable, glass-filled nylon brackets. Simplifies sensor installation and setup, designed for M12, M18 and M30 Threaded Sensors.



Ordering Information

Note: Shaded models are normally stocked. Un-shaded models require 2-3 weeks delivery.

Thread	Model
M12 x 1	Y92E-SUMB-12
M18 x 1	Y92E-SUMB-18
M30 x 1.5	Y92E-SUMB-30

Dimensions

Unit: mm (inch)

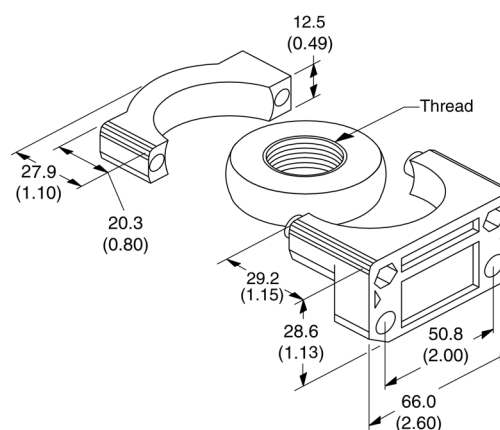

■ Proximity Sensor Spring Mount Threaded Housings

Acts as a shock absorber



Build compliance into your sensor mounting brackets to eliminate sensor damage due to target and tooling collisions. Spring mount threaded housings offer over-travel protection, resistance to abrasion, quicker installation and spare parts reduction. Spring mount threaded housings are available in anodized aluminum construction or in stainless steel versions for M8, M12, M18 and M30 shielded or unshielded proximity sensors. Plastic end caps are utilized to deflect targets approaching the sensor laterally and are included with the hardware.

Ordering Information

Note: Shaded models are normally stocked. Un-shaded models require 2-3 weeks delivery.

Barrel size	Description	Model
M8	Spring Mount for M8 Shielded Anodized Aluminum	Y92E-GS08
M8	Spring Mount for M8 Unshielded Anodized Aluminum	Y92E-GS08N
M12	Spring Mount for M12 Shielded Anodized Aluminum	Y92E-GS12
M12	Spring Mount for M12 Unshielded Anodized Aluminum	Y92E-GS12N
M18	Spring Mount for M18 Shielded Anodized Aluminum	Y92E-GS18
M18	Spring Mount for M18 Unshielded Anodized Aluminum	Y92E-GS18N
M30	Spring Mount for M30 Shielded Anodized Aluminum	Y92E-GS30
M30	Spring Mount for M30 Unshielded Anodized Aluminum	Y92E-GS30N
M8	Spring Mount for M8 Shielded Stainless Steel	Y92E-GS08-SS
M8	Spring Mount for M8 Unshielded Stainless Steel	Y92E-GS08N-SS
M12	Spring Mount for M12 Shielded Stainless Steel	Y92E-GS12-SS
M12	Spring Mount for M12 Unshielded Stainless Steel	Y92E-GS12N-SS
M18	Spring Mount for M18 Shielded Stainless Steel	Y92E-GS18-SS
M18	Spring Mount for M18 Unshielded Stainless Steel	Y92E-GS18N-SS
M30	Spring Mount for M30 Shielded Stainless Steel	Y92E-GS30-SS
M30	Spring Mount for M30 Unshielded Stainless Steel	Y92E-GS30N-SS

Dimensions

Unit: mm (inch)

Spring Mount Threaded Housings

Model numbers ending in "U" are unshielded type and are depicted on the right. "O" dimension in the table is total allowable over travel. Stainless Steel version dimensions are identical.

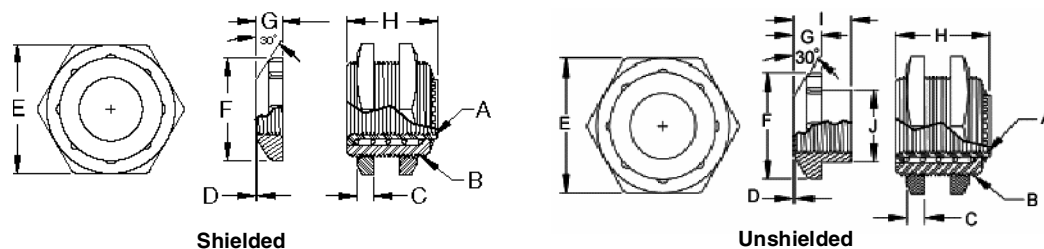

A	B	C	D	E	F	G	H	I	J	O	Model
M8x1	M16 x1.5	3.1 (0.12)	0.25 (0.01)	22.1 (0.87)	15.1 (0.59)	5.1 (0.20)	22.1 (0.87)	N/A	N/A	9.04 (0.35)	Y92E-GS08
								9.51 (0.37)	11 (0.43)		Y92E-GS08N
M12x1	M22 x1.5	4.06 (0.16)	0.51 (0.02)	28.6 (1.12)	22.9 (0.90)	6.35 (0.25)	22.1 (0.87)	N/A	N/A	10.4 (0.41)	Y92E-GS12
								17.3 (0.68)	14.7 (0.58)		Y92E-GS12N
M18x1	M30 x1.5	5.10 (0.20)	0.76 (0.03)	35.8 (1.41)	29.7 (1.17)	8.38 (0.33)	29.7 (1.17)	N/A	N/A	12.4 (0.49)	Y92E-GS18
								17.8 (0.70)	23.9 (0.94)		Y92E-GS18N
M30x1.5	M47 x1.5			51.0 (2.01)	43.7 (1.72)	7.62 (0.30)	37.3 (1.47)	N/A	N/A	14.5 (0.57)	Y92E-GS30
								20.9 (0.90)	38.6 (1.52)		Y92E-GS30N

■ Proximity Sensor Spring Mount Blocks

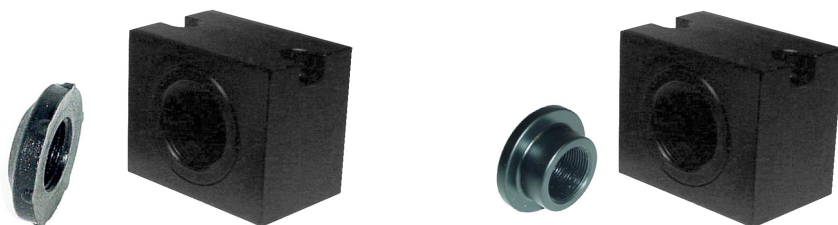

Shielded Models

Unshielded Models

Offers the same protection as the threaded housings, available in anodized aluminum for M12, M18 and M30 shielded or unshielded proximity sensors. Plastic beveled end caps are included.

Ordering Information

Note: Shaded models are normally stocked. Un-shaded models require 2-3 weeks delivery.

Barrel size	Description	Model
M8	Spring Mount Block for M8 Shielded Anodized Aluminum	Y92E-GSB08
M8	Spring Mount Block for M8 Unshielded Anodized Aluminum	Y92E-GSB08N
M12	Spring Mount Block for M12 Shielded Anodized Aluminum	Y92E-GSB12
M12	Spring Mount Block for M12 Unshielded Anodized Aluminum	Y92E-GSB12N
M18	Spring Mount Block for M18 Shielded Anodized Aluminum	Y92E-GSB18
M18	Spring Mount Block for M18 Unshielded Anodized Aluminum	Y92E-GSB18N
M30	Spring Mount Block for M30 Shielded Anodized Aluminum	Y92E-GSB30
M30	Spring Mount Block for M30 Unshielded Anodized Aluminum	Y92E-GSB30N

Dimensions

Unit: mm (inch)

Spring Mount Blocks

Model numbers ending in "N" are unshielded type and are depicted on the right, shielded models are depicted on the left. "O" dimension in the table is total allowable over travel. Dimensions for Stainless Steel versions are identical.

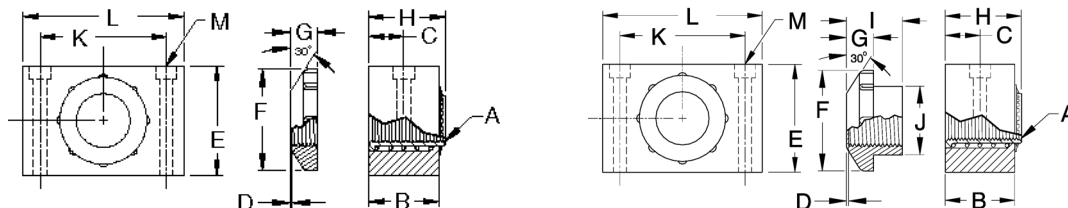

A	B	C	D	E	F	G	H	I	J	K	L	M	O	Model
M8x1	19.0 (0.75)	9.52 (0.37)	0.25 (0.01)	15.8 (0.62)	15.2 (0.60)	5.33 (0.21)	22.1 (0.87)	N/A	N/A	18.4 (0.72)	25.4 (1.00)	3.58 (0.14)	8.89 (0.35)	Y92E-GSB08
								9.51 (0.37)	11 (0.43)					Y92E-GSB08N
M12x1			0.51 (0.02)	25.4 (1.00)	22.9 (0.90)	6.35 (0.25)		N/A	N/A	24.8 (0.98)	38.1 (1.50)	5.16 (0.20)	10.4 (0.41)	Y92E-GSB12
								17.3 (0.68)	14.7 (0.58)					Y92E-GSB12N
M18x1	25.4 (1.00)	12.7 (0.50)	0.76 (0.03)	31.7 (1.25)	29.7 (1.17)	8.38 (0.33)	29.7 (1.17)	N/A	N/A	30.7 (1.21)		4.60 (0.18)	12.4 (0.47)	Y92E-GSB18
								17.8 (0.70)	23.9 (0.94)					Y92E-GSB18N
M30 x1.5	34.9 (1.38)	17.5 (0.68)		50.8 (2.00)	43.7 (1.72)	7.62 (0.30)	37.4 (1.47)	N/A	N/A	51.5 (2.03)	63.5 (2.50)	6.73 (0.26)	14.5 (0.57)	Y92E-GSB30
								22.9 (0.90)	38.6 (1.52)					Y92E-GSB30N

■ Replacement Beveled Plastic End Caps for Use with Spring Mounts



Replacement beveled plastic end caps only are available for spring mount threaded and block style housings. Please determine the Prox. Barrel size and if it is shielded or unshielded type. Shielded types are glass filled Nylon, unshielded types are Delrin®.

Ordering Information

Note: Shaded models are normally stocked. Un-shaded models require 2-3 weeks delivery.

For barrel size	Description	Model
M8	Replacement End Cap for M8 Prox Shielded	Y92E-ES08
M8	Replacement End Cap for M8 Prox Unshielded	Y92E-ES08M
M12	Replacement End Cap for M12 Prox Shielded	Y92E-ES12
M12	Replacement End Cap for M12 Prox Unshielded	Y92E-ES12M
M18	Replacement End Cap for M18 Prox Shielded	Y92E-ES18
M18	Replacement End Cap for M18 Prox Unshielded	Y92E-ES18M
M30	Replacement End Cap for M30 Prox Shielded	Y92E-ES30
M30	Replacement End Cap for M30 Prox Unshielded	Y92E-ES30M

Dimensions

Unit: mm (inch)

Replacement Beveled Plastic Caps for Use with Spring Mount Housings

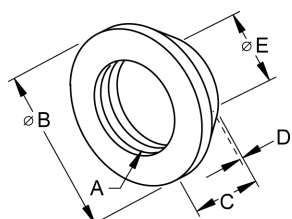

Shielded Type Glass Filled Nylon

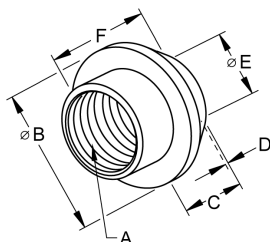

Unshielded Type Delrin®

A	B	C	D	E	F	Model
M8x1	15.2 (.600)	5.28 (.210)	0.38 (.015)	6.45 (.250)	N/A	Y92E-ES08
	14.5 (.570)	5.08 (.200)			9.50 (.370)	Y92E-ES08M
M12x1	24.4 (.960)	6.35 (.250)	0.76 (.030)	11.4 (.450)	N/A	Y92E-ES12
	22.9 (.900)				17.3 (.680)	Y92E-ES12M
M18x1	31.3 (1.23)	8.38 (.330)		17.5 (.730)	N/A	Y92E-ES18
	34.0 (1.34)				17.8 (.700)	Y92E-ES18M
M30x1.5	43.7 (1.72)	7.62 (.300)	1.02 (.040)	29.2 (1.15)	N/A	Y92E-ES30
	44.5 (1.75)	7.87 (.310)			22.9 (.900)	Y92E-ES30M

■ Fast Mount Tubes, Fluoroplastic Coated Fast Mount Tubes and Fluoroplastic Resin Caps for Proximity Sensors



Install proximity sensors into the tube and simply twist to secure. Maintains sensing gap, reduces installation time. Standard versions are nickel-plated brass, Fluoroplastic coated versions protect the sensor from the harshest environments. Fluoroplastic resin end caps for fast mount tubes are also listed below. Dimensions differ from standard sensor caps for use on sensors not mounted in fast mount tubes. Caps are sold separately. Fast Mount Tubes are not Spring Loaded.

Ordering Information

Note: Shaded models are normally stocked. Un-shaded models require 2-3 weeks delivery.

Barrel size	Description	Model
M8 Short	Fast Mount Tube for M8 Short Barrel Prox NPB	Y92E-G08S
M8 Long	Fast Mount Tube for M8 Long Barrel Prox NPB	Y92E-G08L
M12 Short	Fast Mount Tube for M12 Short Barrel Prox NPB	Y92E-G12S
M12 Long	Fast Mount Tube for M12 Long Barrel Prox NPB	Y92E-G12L
M18 Short	Fast Mount Tube for M18 Short Barrel Prox NPB	Y92E-G18S
M18 Long	Fast Mount Tube for M18 Long Barrel Prox NPB	Y92E-G18L
M30 Short	Fast Mount Tube for M30 Short Barrel Prox NPB	Y92E-G30S
M30 Long	Fast Mount Tube for M30 Long Barrel Prox NPB	Y92E-G30L
M8 Short	Fast Mount Tube for M8 Short Barrel Prox Fluoroplastic Coated	Y92E-G08S-T
M8 Long	Fast Mount Tube for M8 Long Barrel Prox Fluoroplastic Coated	Y92E-G08L-T
M12 Short	Fast Mount Tube for M12 Short Barrel Prox Fluoroplastic Coated	Y92E-G12S-T
M12 Long	Fast Mount Tube for M12 Long Barrel Prox Fluoroplastic Coated	Y92E-G12L-T
M18 Short	Fast Mount Tube for M18 Short Barrel Prox Fluoroplastic Coated	Y92E-G18S-T
M18 Long	Fast Mount Tube for M18 Long Barrel Prox Fluoroplastic Coated	Y92E-G18L-T
M30 Short	Fast Mount Tube for M30 Short Barrel Prox Fluoroplastic Coated	Y92E-G30S-T
M30 Long	Fast Mount Tube for M30 Long Barrel Prox Fluoroplastic Coated	Y92E-G30L-T
M8	Fluoroplastic Cap for M8 Prox mounted in a Fast Mount Tube	Y92E-EG08-T
M12	Fluoroplastic Cap for M12 Prox mounted in a Fast Mount Tube	Y92E-EG12-T
M18	Fluoroplastic Cap for M18 Prox mounted in a Fast Mount Tube	Y92E-EG18-T
M30	Fluoroplastic Cap for M30 Prox mounted in a Fast Mount Tube	Y92E-EG30-T

Dimensions

Unit: mm (inch)

Fast Mount Tubes

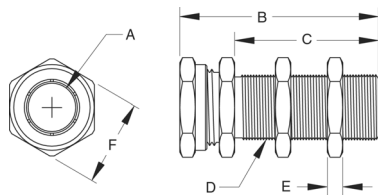

A	B	C	D	E	F	Model
8.18 (0.32)	32.4 (1.28)	17.5 (0.69)	M12x1	3.85 (0.15)	16.9 (0.67)	Y92E-G08S
	48.0 (1.93)	34.0 (1.34)				Y92E-G08L
12.1 (0.48)	33.7 (1.34)	19.5 (0.77)	M16x1	4.01 (0.16)	21.8 (0.86)	Y92E-G12S
	44.8 (1.76)	30.0 (1.18)				Y92E-G12L
18.1 (0.71)	38.5 (1.52)	20.0 (0.79)	M24x1.5	4.95 (0.19)	30.0 (1.18)	Y92E-G18S
	58.0 (2.28)	40.0 (1.57)				Y92E-G18L
30.1 (1.19)	35.0 (1.50)	20.0 (0.79)	M36x1.5	6.13 (0.24)	41.0 (1.61)	Y92E-G30S
	58.0 (2.28)	40.0 (1.57)				Y92E-G30L

Fluoroplastic Resin Sensor Caps for use with Sensors in Fast Mount Tubes

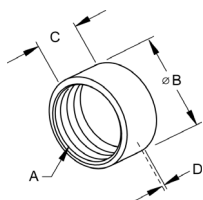

A	B	C	D	Model
M12x1	14.7 (0.58)	8.89 (0.35)	0.89 (.035)	Y92E-EG08-T
M16x1	19.1 (.750)	7.11 (0.28)	1.02 (.040)	Y92E-EG12-T
M24x1.5	28.4 (1.12)	8.89 (0.35)	1.27 (.0)	Y92E-EG18-T
M36x1.5	41.1 (1.62)		1.78 (.070)	Y92E-EG30-T

■ Sensor Caps Standard Versions in Fluoroplastic or Ceramic (not for use with fast mount tubes)



Ordering Information

Note: Shaded models are normally stocked. Un-shaded models require 2-3 weeks delivery.

Barrel size	Description	Model
M12	Fluoroplastic Sensor Cap for M12 Shielded Prox	Y92E-SC12-T
M12	Fluoroplastic Sensor Cap for M12 Unshielded Prox	Y92E-SC12N-T
M12	Ceramic Sensor Cap for M12 Shielded Prox	Y92E-SC12-C
M12	Ceramic Sensor Cap for M12 Unshielded Prox	Y92E-SC12N-C
M18	Fluoroplastic Sensor Cap for M18 Shielded Prox	Y92E-SC18-T
M18	Fluoroplastic Sensor Cap for M18 Unshielded Prox	Y92E-SC18N-T
M18	Ceramic Sensor Cap for M18 Shielded Prox	Y92E-SC18-C
M18	Ceramic Sensor Cap for M18 Unshielded Prox	Y92E-SC18N-C
M30	Fluoroplastic Sensor Cap for M30 Shielded Prox	Y92E-SC30-T
M30	Fluoroplastic Sensor Cap for M30 Unshielded Prox	Y92E-SC30N-T
M30	Ceramic Sensor Cap for M30 Shielded Prox	Y92E-SC30-C
M30	Ceramic Sensor Cap for M30 Unshielded Prox	Y92E-SC30N-C

Dimensions

Unit: mm (inch)

Sensor Caps Standard Versions in Fluoroplastic or Ceramic

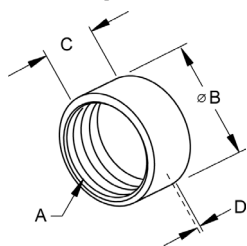

A	B	C	D	Model
M12x1	14.7 (0.58)	8.90 (0.35)	0.89 (.035)	Y92E-SC12
		15.2 (0.60)		Y92E-SC12N
M18x1	24.1 (0.95)	8.90 (0.35)	1.14 (.045)	Y92E-SC18
		17.8 (0.70)		Y92E-SC18N
M30x1.5	38.1 (1.50)	9.90 (0.39)	2.03 (0.08)	Y92E-SC30
		25.4 (1.00)		Y92E-SC30N

■ Sensor Caps Standard Versions Polyallylate Resin (not for use with fast mount tubes)

Ordering Information

Note: Shaded models are normally stocked. Un-shaded models require 2-3 weeks delivery.

Barrel size	Description	Model
M12	Polyallylate Resin Sensor Cap for M12 Shielded Prox	Y92E-E12
M12	Polyallylate Resin Sensor Cap for M12 Unshielded Prox	Y92E-E12M
M18	Polyallylate Resin Sensor Cap for M18 Shielded Prox	Y92E-E18
M18	Polyallylate Resin Sensor Cap for M18 Unshielded Prox	Y92E-E18M
M30	Polyallylate Resin Sensor Cap for M30 Shielded Prox	Y92E-E30
M30	Polyallylate Resin Sensor Cap for M30 Unshielded Prox	Y92E-E30M

Dimensions

Unit: mm (inch)

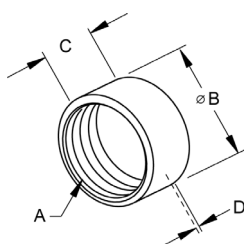

A	B	C	D	Model
M12x1	14mm dia.	5	0.5	Y92E-E12
		12		Y92E-E12M
M18x1	21mm dia.	6	1	Y92E-E18
		16		Y92E-E18M
M30x1.5	33mm dia.	8	1.5	Y92E-E30
		21		Y92E-E30M

■ Ceramic Face Disc

A ceramic face disc can be bonded to the sensing face of M12, M18 and M30 Proximity Sensors to protect the sensor from highly abrasive environments.



Ordering Information

Note: Shaded models are normally stocked. Un-shaded models require 2-3 weeks delivery.

Barrel size	Description	Model
M8	Ceramic Face Disc for M8 Prox	Y92E-CF08
M12	Ceramic Face Disc for M12 Prox	Y92E-CF12
M18	Ceramic Face Disc for M18 Prox	Y92E-CF18
M30	Ceramic Face Disc for M30 Prox	Y92E-CF30

Dimensions

Unit: mm (inch)

M8, M12, M18 and M30 Proximity Sensors

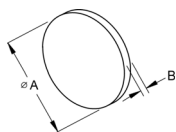

A	B	Model
5.80 (0.23)	0.3 (0.012)	Y92E-CF08
10.4 (0.41)		Y92E-CF12
15.2 (0.60)	0.50 (.020)	Y92E-CF18
27.9 (1.10)		Y92E-CF30

■ Silicone Rubber Protective Covers

Ordering Information

Note: Shaded models are normally stocked. Un-shaded models require 2-3 weeks delivery.

Barrel size	Description	Model
M12	Silicone Rubber Protective Cover for M12 Prox	Y92E-E12-2
M18	Silicone Rubber Protective Cover for M18 Prox	Y92E-E18-2
M30	Silicone Rubber Protective Cover for M30 Prox	Y92E-E30-2

Dimensions

Unit: mm (inch)

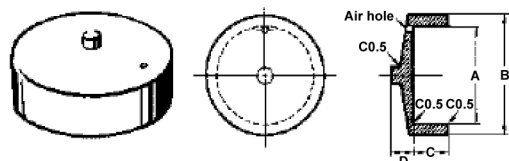

Dimensions				Model
A dia.	B dia.	C	D	
11.0 (0.43)	14.0 (0.55)	5.0 (0.20)	1.0 (0.04)	Y92E-E12-2
17.0 (0.67)	21.0 (0.83)	6.0 (0.24)	3.0 (0.12)	Y92E-E18-2
28.5 (1.12)	33.0 (1.30)	8.0 (0.32)	6.0 (0.24)	Y92E-E30-2

■ Block Mounts Threaded Metal (Anodized Aluminum)

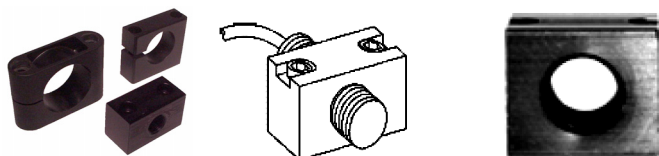

Install your proximity sensors into rugged heavy-duty anodized aluminum threaded block style mounts.

Ordering Information

Note: Shaded models are normally stocked. Un-shaded models require 2-3 weeks delivery.

Barrel size	Description	Model
M8	Block Mount Threaded Metal for M8 Barrel Prox	Y92E-B08MT
M12	Block Mount Threaded Metal for M12 Barrel Prox	Y92E-B12MT
M18	Block Mount Threaded Metal for M18 Barrel Prox	Y92E-B18MT
M30	Block Mount Threaded Metal for M30 Barrel Prox	Y92E-B30MT

Dimensions

Unit: mm (inch)

M8, M12, M18 and M30 Version

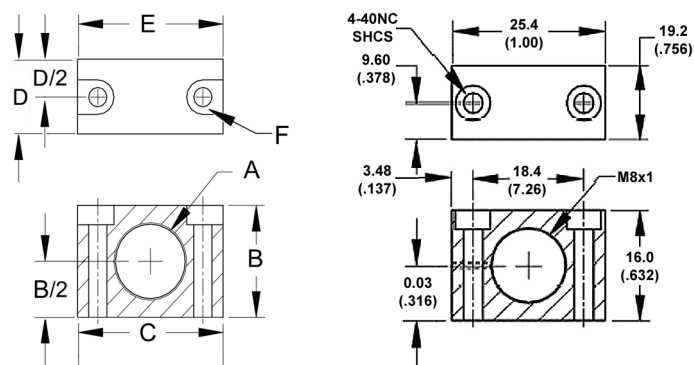

A	B	C	D	E	F	G	Model
M12x1	25.4 (1.00)	19.2 (.758)	38.1 (1.50)	25.0 (.980)	6.60 (.260)	10-32 SHCS	Y92E-B12MT
M18x1	31.8 (1.25)	25.4 (1.00)		30.7 (1.21)	3.70 (.145)	8-32 SHCS	Y92E-B18MT
M30x1.5	50.8 (2.00)	33.1 (1.30)	63.5 (2.50)	51.6 (2.03)	5.97 (.235)	1/4 SHCS	Y92E-B30MT

■ Flat and Right Angle Mounting Brackets

Brackets are available in fixed or slotted (adjustable) versions.

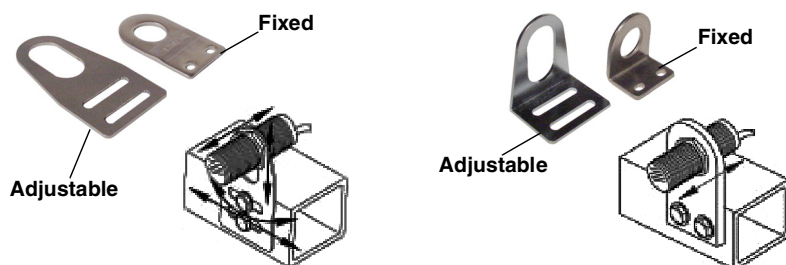

Ordering Information

Note: Shaded models are normally stocked. Un-shaded models require 2-3 weeks delivery.

For barrel size	Description	Model
M12	Flat Bracket Fixed for M12 Prox 303 Stainless Steel	Y92E-B12FS
M18	Flat Bracket Fixed for M18 Prox 303 Stainless Steel	Y92E-B18FS
M30	Flat Bracket Fixed for M30 Prox 303 Stainless Steel	Y92E-B30FS
M8	Flat Bracket Adjustable for M8 Prox Zinc-plated CRS	Y92E-B08FRAS
M12	Flat Bracket Adjustable for M12 Prox Zinc-plated CRS	Y92E-B12FRAS
M18	Flat Bracket Adjustable for M18 Prox Zinc-plated CRS	Y92E-B18FRAS
M30	Flat Bracket Adjustable for M30 Prox Zinc-plated CRS	Y92E-B30FRAS
M12	Right Angle Bracket Fixed for M12 Prox 303 SS	Y92E-B12AS
M18	Right Angle Bracket Fixed for M18 Prox 303 SS	Y92E-B18AS
M30	Right Angle Bracket Fixed for M30 Prox 303 SS	Y92E-B30AS
M8	Right Angle Bracket Adjustable for M8 Prox Zinc-plated CRS	Y92E-B08RAS
M12	Right Angle Bracket Adjustable for M12 Prox Zinc-plated CRS	Y92E-B12RAS
M18	Right Angle Bracket Adjustable for M18 Prox Zinc-plated CRS	Y92E-B18RAS
M30	Right Angle Bracket Adjustable for M30 Prox Zinc-plated CRS	Y92E-B30RAS

Dimensions

Unit: mm (inch)

Flat Bracket Fixed Hole

Mounting; Material is 303 Stainless Steel.

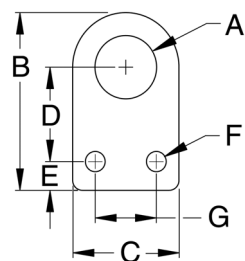

A	B	C	D	E	F	G	Material thickness	Model
12.1 (.476)	48.8 (1.92)	31.8 (1.25)	5.50 (.216)	19.1 (.750)	11.9 (.470)	32.9 (1.30)	3.05 (.120)	Y92E-B12FS
18.1 (.713)	58.4 (2.30)	38.1 (1.50)	6.12 (.241)	25.4 (1.00)	7.37 (.290)	41.4 (1.63)		Y92E-B18FS
30.1 (1.18)	87.1 (3.43)	50.8 (2.00)	9.93 (.312)	31.8 (1.25)	9.53 (.375)	61.4 (2.42)		Y92E-B30FS

Flat Bracket Slotted (Adjustable) Hole

Mounting; Material is Zinc-plated carbon steel.

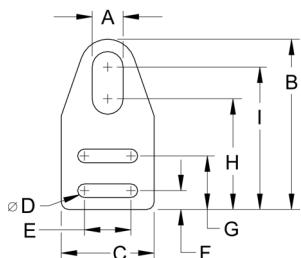

A	B	C	D	E	F	G	H	I	Material thickness	Model	
8.10 (.319)	54.3 (2.14)	31.7 (1.25)	5.60 (.220)	15.9 (.625)	7.14 (.281)	19.0 (.749)	38.7 (1.52)	46.2 (1.82)	1.78 (.070)	Y92E-B08FRAS	
12.1 (.476)	69.9 (2.75)	38.1 (1.50)		19.1 (.750)	7.92 (.312)		22.2 (.875)	45.7 (1.80)		58.4 (2.30)	Y92E-B12FRAS
18.1 (.713)	82.6 (3.25)	44.5 (1.75)		25.4 (1.00)				50.8 (2.00)		66.7 (2.63)	Y92E-B18FRAS
30.1 (1.18)	105 (4.11)	57.2 (2.25)	7.24 (.285)	34.8 (1.37)	10.3 (.406)	30.9 (1.22)	49.0 (1.93)	61.2 (2.14)	2.16 (.095)	Y92E-B30FRAS	

Right Angle Bracket Fixed Hole

Mounting; Material is 303 Stainless Steel.

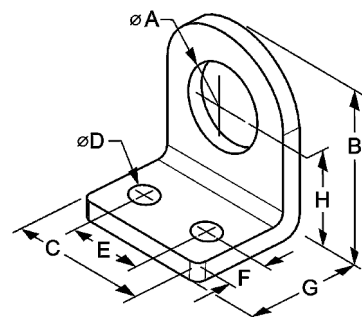

A	B	C	D	E	F	G	H	Material thickness	Model
12.1 (.476)	28.6 (1.13)	31.8 (1.25)	5.50 (.216)	19.1 (.750)	11.9 (.470)	25.4 (1.00)	13.5 (.530)	3.00 (.118)	Y92E-B12AS
18.1 (.713)	38.5 (1.52)	38.1 (1.50)	6.12 (.241)	25.4 (1.00)	7.37 (.290)		19.8 (.781)		Y92E-B18AS
30.1 (1.18)	54.3 (2.14)	50.8 (2.00)	7.92 (.312)	31.8 (1.25)	9.53 (.375)	38.0 (1.50)	28.6 (1.13)		Y92E-B30AS

Right Angle Bracket Slotted (Adjustable) Hole

Mounting; Material is Zinc-plated carbon steel.

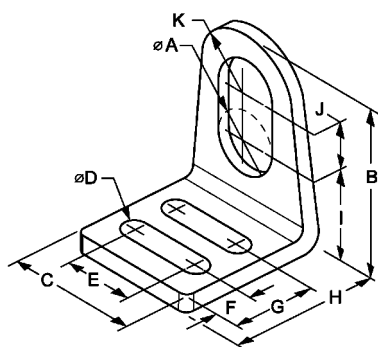

A	B	C	D	E	F	G	H	I	J	K	Material thickness	Model
8.1 (.319)	25.4 (1.00)	31.8 (1.25)	5.54 (.218)	15.9 (.625)	7.14 (.281)	19 (.749)	31.8 (1.25)	9.83 (.387)	7.62 (.300)	7.95 (.313)	1.78 (.070)	Y92E-B08RAS
12.1 (.476)	38.1 (1.50)	38.1 (1.50)		19.1 (.750)	7.92 (.312)	22.2 (.875)	34.8 (1.37)	14.0 (.550)	12.7 (.500)	11.4 (.450)		Y92E-B12RAS
18.1 (.713)	50.8 (2.00)	44.5 (1.75)		25.4 (1.00)				19.1 (.750)	15.9 (.625)	15.9 (.625)		Y92E-B18RAS
30.1 (1.18)	63.5 (2.50)	57.2 (2.25)	7.13 (.281)	34.8 (1.37)	10.3 (.406)	30.9 (1.22)	44.5 (1.75)	23.0 (.907)	19.1 (.750)	21.4 (.843)	2.16 (.095)	Y92E-B30RAS

■ Sight Glass Mounts

Quickly attach tubular sensors to glass and plastic tubes for level detection. Often used in pairs (high-low) to detect absence or presence of liquids to activate pumps and drains in process control applications. Sight glass mounts offer adjustments “on the fly” with visual feedback for M12, M18 and M30 sensors, mounted to 9.5mm (3/8”) through 44mm (1-3/4”) pipes. Delrin® construction with all stainless steel fasteners provides corrosion resistance. Instantly converts tubular controls to level sensors, rapid, “out of tank” level adjustments, simple sensor change-out / replacement and very secure mounting.

Ordering Information

Note: Shaded models are normally stocked. Un-shaded models require 2-3 weeks delivery.

Barrel size	Description	Model
M12	Sight Glass Mount for M12 Barrel Prox	Y92E-SGM12
M18	Sight Glass Mount for M18 Barrel Prox	Y92E-SGM18
M30	Sight Glass Mount for M30 Barrel Prox	Y92E-SGM30
M30 (34mm)	Sight Glass Mount for M30 (34mm) Barrel Prox	Y92E-SGM34

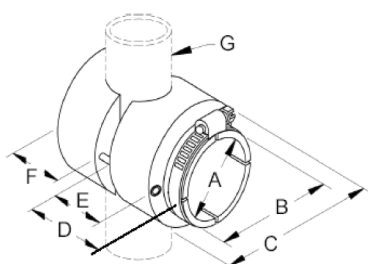
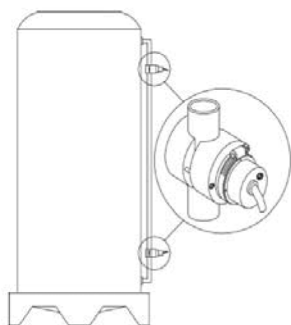

Dimensions

Unit: mm (inch)

A	B	C	D	E	F	G	Model
12.1 (0.48)	19.6 (0.77)	38.1 (1.50)	29.5 (1.16)	13.0 (0.51)	10.5 (0.42)	9.40 to 20.6 (0.37 to 0.81)	Y92E-SGM12
18.1 (0.71)	25.4 (1.00)	45.0 (1.77)	38.1 (1.50)	15.9 (0.63)	11.7 (0.46)		Y92E-SGM18
30.1 (1.19)	36.8 (1.45)	69.9 (2.75)	67.8 (2.69)	31.8 (1.25)	19.1 (0.75)	25.4 to 44.5 (1.00 to 1.75)	Y92E-SGM30
34.1 (1.34)							Y92E-SGM34

■ Sensor Wells

Sensor Wells are used to adapt tubular proximity sensors to a wide variety of vessels for level detection applications. Different style wells allow a variety of attachment options. Sensor Wells keep systems sealed prior to sensor installation, as well as during sensor removal. Reliability and performance is improved because the sensor is isolated from the system fluids / materials. Sensor Wells are available in Delrin®, HDPE and Fluoroplastic models Flange Mount, SAE & NPT threads. Sensor Wells isolate sensor from system fluids / materials, offers a highly reliable sealing method, simplifies sensor change-out process and extends the sensor operating lifetime. Maximum operating temperature for SWNPT Delrin version is 180 degrees F. Maximum operating temperature for SWNPT Fluoroplastic version is 350 degrees F. Maximum operating temperature for SWSAE UHMW material is 150 degrees F.



SAE Thread Model



Flange Mount Model



NPT Model

Ordering Information

Note: Shaded models are normally stocked. Un-shaded models require 2-3 weeks delivery.

Sensor well type	Description	Model
Flange Mount	Sensor Well Flange Mount M30 Proximity	Y92E-SWFM30
Flange Mount	Sensor Well Flange Mount M30 (34mm) Proximity	Y92E-SWFM34
NPT Thread	Sensor Well NPT Thread Delrin M12	Y92E-SWNPT12-D
NPT Thread	Sensor Well NPT Thread Fluoroplastic M12	Y92E-SWNPT12-T
NPT Thread	Sensor Well NPT Thread Delrin M18	Y92E-SWNPT18-D
NPT Thread	Sensor Well NPT Thread Fluoroplastic M18	Y92E-SWNPT18-T
NPT Thread	Sensor Well NPT Thread Delrin M30	Y92E-SWNPT30-D
NPT Thread	Sensor Well NPT Thread Fluoroplastic M30	Y92E-SWNPT30-T
NPT Thread	Sensor Well NPT Thread Delrin 34mm	Y92E-SWNPT34-D
NPT Thread	Sensor Well NPT Thread Fluoroplastic 34mm	Y92E-SWNPT34-T
SAE Thread	Sensor Well SAE Thread Delrin M18	Y92E-SWSAE18-D

Note: Flange Mount Smooth Bore (SWFM) models are fabricated using UHMW polyethylene. The O-ring, with an OD of 88.0(3.46), produces the seal and is supplied with Sensor Well.

Dimensions

Unit: mm (inch)

Sensor Well Flange Mount

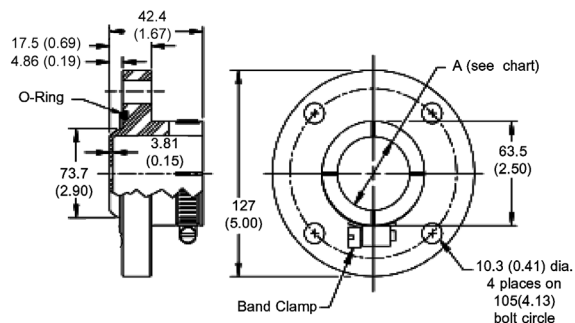

"A" Dimension	Model
30.1 (1.19)	Y92E-SWFM30
34.1 (1.35)	Y92E-SWFM34

Sensor Well NPT Thread

A	B	C	D	E	F	NPT	G	H	I	Model
44.5 (1.75)	33.0 (1.30)	26.7 (1.05)	9.14 (0.36)	0.76 (0.03)	17.8 (0.70)	1/2x14	25.1 (0.99)	31.8 (1.25)	12.1 (0.48)	Y92E-SWNPT12-(D/T)
59.7 (2.35)	48.1 (1.90)	38.9 (1.53)	16.5 (0.65)	1.27 (0.05)	22.6 (0.89)	3/4x14	31.5 (1.24)	37.3 (1.47)	18.1 (0.71)	Y92E-SWNPT18-(D/T)
				1.91 (0.08)	36.6 (1.44)	1-1/4x11.5	44.5 (1.75)	50.0 (1.97)	30.1 (1.19)	Y92E-SWNPT30-(D/T)
				19.3 (0.76)	2.03 (0.08)	41.1 (1.63)	1-1/2x11.5	56.9 (2.24)	63.2 (2.49)	34.1 (1.34)

Sensor Well SAE Thread for M18 Prox

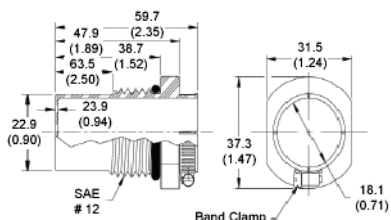

■ Sensor Checker

Full Function Sensor Checker in a pocket-sized non-metallic enclosure. Includes easy push-type terminals making wire connections simple and quick. Allows troubleshooting and or demonstration of DC sensors; 2, 3, 4-wire and NAMUR type sensor built to DIN 19234 specifications. Confirms operation of inductive, photoelectric, capacitive and ultrasonic sensors. Wiring instructions are printed on the case. Includes dual operation indicators LED and buzzer. Uses and is supplied with two 9V batteries. Easily confirm sensor operation, confirm PNP vs. NPN, reduce your troubleshooting time.

Ordering Information

Note: Shaded models are normally stocked. Un-shaded models require 2-3 weeks delivery.

	Model
Sensor Checker includes 2 9V Batteries	Y92E-SC1



Wiring Connections

- NAMUR & 2 wire Sensors
 - Brown to +
 - Blue to Signal
- (18 VDC)
- 3 & 4 wire Sensors
 - Brown to +
 - Blue to - (Ground)
 - White to Signal (NC)
 - Black to Signal (NO)

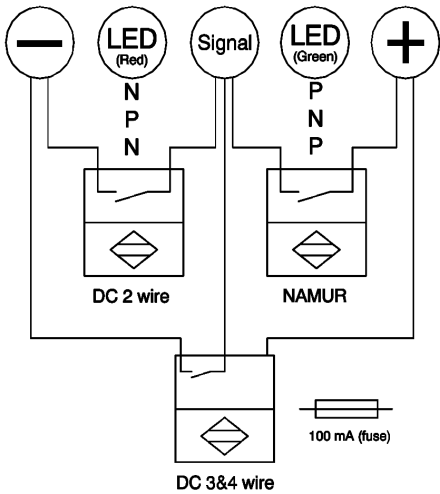

Specifications

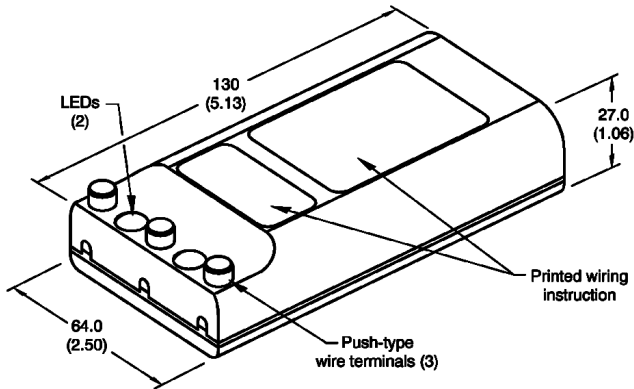

Supply voltage	18 VDC
Maximum rated load	100mA (fused)
Short circuit protection	Yes
Over voltage protection	Yes
LED display	Yes (2)
Audible output	Yes
Operating temperature	Room temperature
Humidity	80% noncondensing
Housing material	ABS
Protection class	IP67
Battery	9v (2)

■ Weld Jacket

Weld Jacket is a protective covering for cordsets. Weld Jacket slips over the cable and the connector portion to offer protection in harsh welding environments. Weld Jacket is available in 1/2" or 3/4" diameter by 3 foot or 50 foot lengths.



Ordering Information

Note: Shaded models are normally stocked. Un-shaded models require 2-3 weeks delivery.

Jacket diameter	Description	Model
1/2"	1/2" Weld Jacket 36 inch length	Y92E-WJ12X36IN
1/2"	1/2" Weld Jacket 50 foot length	Y92E-WJ12X50FT
3/4"	3/4" Weld Jacket 36 inch length	Y92E-WJ34X36IN
3/4"	3/4" Weld Jacket 50 foot length	Y92E-WJ34X50FT

Description: Woven fiberglass sleeving coated with a specially formulated and proprietary silicone rubber. Exhibits exceptional high-temperature properties, flexibility, and toughness and abrasion resistance. Silicone rubber finish provides superior thermal protection, flame resistance and makes it an ideal choice for welding applications requiring outstanding physical and insulation properties in high operating temperatures.

Thermal Endurance: -80°C to +240°C (-112°F to +464°F)

Chemical Endurance:

1. Oil and Solvent Resistance: passes MIL-I-3190/9
2. Water Vapor Resistance: passes MIL-I-3190/9
3. Excellent Resistance to Acids and Alkalis.
4. Resistance to mildew, aging and sunlight: unaffected by sunlight and weather.
5. Compatibility UL 1446 Good. Compatible with most varnishes.

Standards: Exceeds the requirements of UL 1441- table 19.8, NEMA TF-1- type 5 and ASTM-D372.

Certain Terms and Conditions of Sale

1. **Offer; Acceptance.** These terms and conditions (these "Terms") are deemed part of all catalogs, manuals or other documents, whether electronic or in writing, relating to the sale of goods or services (collectively, the "Goods") by Omron Electronics LLC and its subsidiary companies ("Seller"). Seller hereby objects to any terms or conditions proposed in Buyer's purchase order or other documents which are inconsistent with, or in addition to, these Terms. Please contact your Omron representative to confirm any additional terms for sales from your Omron company.
2. **Prices.** All prices stated are current, subject to change without notice by Seller. Buyer agrees to pay the price in effect at time of shipment.
3. **Discounts.** Cash discounts, if any, will apply only on the net amount of invoices sent to Buyer after deducting transportation charges, taxes and duties, and will be allowed only if (i) the invoice is paid according to Seller's payment terms and (ii) Buyer has no past due amounts owing to Seller.
4. **Orders.** Seller will accept no order less than \$200 net billing.
5. **Governmental Approvals.** Buyer shall be responsible for, and shall bear all costs involved in, obtaining any government approvals required for the importation or sale of the Goods.
6. **Taxes.** All taxes, duties and other governmental charges (other than general real property and income taxes), including any interest or penalties thereon, imposed directly or indirectly on Seller or required to be collected directly or indirectly by Seller for the manufacture, production, sale, delivery, importation, consumption or use of the Goods sold hereunder (including customs duties and sales, excise, use, turnover and license taxes) shall be charged to and remitted by Buyer to Seller.
7. **Financial.** If the financial position of Buyer at any time becomes unsatisfactory to Seller, Seller reserves the right to stop shipments or require satisfactory security or payment in advance. If Buyer fails to make payment or otherwise comply with these Terms or any related agreement, Seller may (without liability and in addition to other remedies) cancel any unshipped portion of Goods sold hereunder and stop any Goods in transit until Buyer pays all amounts, including amounts payable hereunder, whether or not then due, which are owing to it by Buyer. Buyer shall in any event remain liable for all unpaid accounts.
8. **Cancellation; Etc.** Orders are not subject to rescheduling or cancellation unless Buyer indemnifies Seller fully against all costs or expenses arising in connection therewith.
9. **Force Majeure.** Seller shall not be liable for any delay or failure in delivery resulting from causes beyond its control, including earthquakes, fires, floods, strikes or other labor disputes, shortage of labor or materials, accidents to machinery, acts of sabotage, riots, delay in or lack of transportation or the requirements of any government authority.
10. **Shipping; Delivery.** Unless otherwise expressly agreed in writing by Seller:
 - a. Shipments shall be by a carrier selected by Seller;
 - b. Such carrier shall act as the agent of Buyer and delivery to such carrier shall constitute delivery to Buyer;
 - c. All sales and shipments of Goods shall be FOB shipping point (unless otherwise stated in writing by Seller), at which point title to and all risk of loss of the Goods shall pass from Seller to Buyer, provided that Seller shall retain a security interest in the Goods until the full purchase price is paid by Buyer;
 - d. Delivery and shipping dates are estimates only.
 - e. Seller will package Goods as it deems proper for protection against normal handling and extra charges apply to special conditions.
11. **Claims.** Any claim by Buyer against Seller for shortage or damage to the Goods occurring before delivery to the carrier must be presented in writing to Seller within 30 days of receipt of shipment and include the original transportation bill signed by the carrier noting that the carrier received the Goods from Seller in the condition claimed.
12. **Warranties.** (a) **Exclusive Warranty.** Seller's exclusive warranty is that the Goods will be free from defects in materials and workmanship for a period of twelve months from the date of sale by Seller (or such other period expressed in writing by Seller). Seller disclaims all other warranties, express or implied. (b) **Limitations.** SELLER MAKES NO WARRANTY OR REPRESENTATION, EXPRESS OR IMPLIED, ABOUT NON-INFRINGEMENT, MERCHANTABILITY OR FITNESS FOR A PARTICULAR PURPOSE OF THE GOODS. BUYER ACKNOWLEDGES THAT IT ALONE HAS DETERMINED THAT THE GOODS WILL SUITABLY MEET THE REQUIREMENTS OF THEIR INTENDED USE. Seller further disclaims all warranties and responsibility of any type for claims or expenses based on infringement by the Goods or otherwise of any intellectual property right. (c) **Buyer Remedy.** Seller's sole obligation hereunder shall be to replace (in the form originally shipped with Buyer responsible for labor charges for removal or replacement thereof) the non-complying Good or, at Seller's election, to repay or credit Buyer an amount equal to the purchase price of the Good; provided that in no event shall Seller be responsible for warranty, repair, indemnity or any other claims or expenses regarding the Goods unless Seller's analysis confirms that the Goods were properly handled, stored, installed and maintained and not subject to contamination, abuse, misuse or inappropriate modification. Return of any goods by Buyer must be approved in writing by Seller before shipment. Seller shall not be liable for the suitability or unsuitability or the results from the use of Goods in combination with any electrical or electronic components, circuits, system assemblies or any other materials or substances or environments. Any advice, recommendations or information given orally or in writing, are not to be construed as an amendment or addition to the above warranty. (d) **Damage Limits; Etc.** SELLER SHALL NOT BE LIABLE FOR SPECIAL, INDIRECT OR CONSEQUENTIAL DAMAGES, LOSS OF PROFITS OR PRODUCTION OR COMMERCIAL LOSS IN ANY WAY CONNECTED WITH THE GOODS, WHETHER SUCH CLAIM IS BASED IN CONTRACT, WARRANTY, NEGLIGENCE OR STRICT LIABILITY. Further, in no event shall liability of Seller exceed the individual price of the Good on which liability is asserted. (e) **Indemnities.** Buyer shall indemnify and hold harmless Seller, its affiliates and its employees from and against all liabilities, losses, claims, costs and expenses (including attorney's fees and expenses) related to any claim, investigation, litigation or proceeding (whether or not Seller is a party) which arises or is alleged to arise from Buyer's acts or omissions under these Terms or in any way with respect to the Goods. Without limiting the foregoing, Buyer (at its own expense) shall indemnify and hold harmless Seller and defend or settle any action brought against Seller to the extent that it is based on a claim that any Good made to Buyer specifications infringed intellectual property rights of another party. (f) **Property; Confidentiality.** The intellectual property embodied in the Goods is the exclusive property of Seller and its affiliates and Buyer shall not attempt to duplicate it in any way without the written permission of Seller. Notwithstanding any charges to Buyer for engineering or tooling, all engineering and tooling shall remain the exclusive property of Seller. All information and materials supplied by Seller to Buyer relating to the Goods are confidential and proprietary, and Buyer shall limit distribution thereof to its trusted employees and strictly prevent disclosure to any third party. (g) **Miscellaneous.** (a) **Waiver.** No failure or delay by Seller in exercising any right and no course of dealing between Buyer and Seller shall operate as a waiver of rights by Seller. (b) **Assignment.** Buyer may not assign its rights hereunder without Seller's written consent. (c) **Amendment.** These Terms constitute the entire agreement between Buyer and Seller relating to the Goods, and no provision may be changed or waived unless in writing signed by the parties. (d) **Severability.** If any provision hereof is rendered ineffective or invalid, such provision shall not invalidate any other provision. (e) **Setoff.** Buyer shall have no right to set off any amounts against the amount owing in respect of this invoice. (f) As used herein, "including" means "including without limitation".

Certain Precautions on Specifications and Use

1. **Suitability of Use.** Seller shall not be responsible for conformity with any standards, codes or regulations which apply to the combination of the Good in the Buyer's application or use of the Good. At Buyer's request, Seller will provide applicable third party certification documents identifying ratings and limitations of use which apply to the Good. This information by itself is not sufficient for a complete determination of the suitability of the Good in combination with the end product, machine, system, or other application or use. The following are some examples of applications for which particular attention must be given. This is not intended to be an exhaustive list of all possible uses of this Good, nor is it intended to imply that the uses listed may be suitable for this Good:
 - (i) Outdoor use, uses involving potential chemical contamination or electrical interference, or conditions or uses not described in this document.
 - (ii) Energy control systems, combustion systems, railroad systems, aviation systems, medical equipment, amusement machines, vehicles, safety equipment, and installations subject to separate industry or government regulations.
 - (iii) Systems, machines and equipment that could present a risk to life or property. Please know and observe all prohibitions of use applicable to this Good.
2. **Programmable Products.** Seller shall not be responsible for the user's programming of a programmable Good, or any consequence thereof.
3. **Performance Data.** Performance data given in this catalog is provided as a guide for the user in determining suitability and does not constitute a warranty. It may represent the result of Seller's test conditions, and the user must correlate it to actual application requirements. Actual performance is subject to the Seller's Warranty and Limitations of Liability.
4. **Change in Specifications.** Product specifications and accessories may be changed at any time based on improvements and other reasons. It is our practice to change part numbers when published ratings or features are changed or when significant construction changes are made. However, some specifications of the Good may be changed without any notice. When in doubt, specific part numbers may be assigned to fix or establish key specifications for your application. Please consult with your Seller's representative at any time to confirm actual specifications of purchased Good.
5. **Errors and Omissions.** The information in this catalog has been carefully checked and is believed to be accurate; however, no responsibility is assumed for clerical, typographical or proofreading errors, or omissions.

NEVER USE THE PRODUCT FOR AN APPLICATION INVOLVING SERIOUS RISK TO LIFE OR PROPERTY WITHOUT ENSURING THAT THE SYSTEM AS A WHOLE HAS BEEN DESIGNED TO ADDRESS THE RISKS, AND THAT THE SELLER'S PRODUCT IS PROPERLY RATED AND INSTALLED FOR THE INTENDED USE WITHIN THE OVERALL EQUIPMENT OR SYSTEM.

Complete "Terms and Conditions of Sale" for product purchase and use are on Omron's website at www.omron.com/oei – under the "About Us" tab, in the Legal Matters section.

OMRON[®]

OMRON ELECTRONICS LLC

One Commerce Drive
Schaumburg, IL 60173

847-843-7900

For US technical support or other inquiries:

800-556-6766

OMRON CANADA, INC.

885 Milner Avenue
Toronto, Ontario M1B 5V8

416-286-6465

OMRON ON-LINE

Global - <http://www.omron.com>
USA - <http://www.omron.com/oei>
Canada - <http://www.omron.ca>



Компания «ЭлектроПласт» предлагает заключение долгосрочных отношений при поставках импортных электронных компонентов на взаимовыгодных условиях!

Наши преимущества:

- Оперативные поставки широкого спектра электронных компонентов отечественного и импортного производства напрямую от производителей и с крупнейших мировых складов;
- Поставка более 17-ти миллионов наименований электронных компонентов;
- Поставка сложных, дефицитных, либо снятых с производства позиций;
- Оперативные сроки поставки под заказ (от 5 рабочих дней);
- Экспресс доставка в любую точку России;
- Техническая поддержка проекта, помощь в подборе аналогов, поставка прототипов;
- Система менеджмента качества сертифицирована по Международному стандарту ISO 9001;
- Лицензия ФСБ на осуществление работ с использованием сведений, составляющих государственную тайну;
- Поставка специализированных компонентов (Xilinx, Altera, Analog Devices, Intersil, Interpoint, Microsemi, Aeroflex, Peregrine, Syfer, Eurofarad, Texas Instrument, Miteq, Cobham, E2V, MA-COM, Hittite, Mini-Circuits, General Dynamics и др.);

Помимо этого, одним из направлений компании «ЭлектроПласт» является направление «Источники питания». Мы предлагаем Вам помощь Конструкторского отдела:

- Подбор оптимального решения, техническое обоснование при выборе компонента;
- Подбор аналогов;
- Консультации по применению компонента;
- Поставка образцов и прототипов;
- Техническая поддержка проекта;
- Защита от снятия компонента с производства.



Как с нами связаться

Телефон: 8 (812) 309 58 32 (многоканальный)

Факс: 8 (812) 320-02-42

Электронная почта: org@eplast1.ru

Адрес: 198099, г. Санкт-Петербург, ул. Калинина, дом 2, корпус 4, литера А.