



PS-100 Series Specifications



Features:

- Universal AC input / full range
- Protections: Short Circuit / Overload / Over Voltage / Overtemperature
- Cooling by free air convection
- DIN rail mountable
- Isolation class II
- LED indicator for power on
- No load power consumption <1W
- 100% full load burn-in test
- 3 year warranty

OUTPUT

INPUT

PROTECTION

ENVIRONMENT

SAFETY & EMC

OTHERS

Cat. No.	PS-10012	PS-10015	PS-10024
DC VOLTAGE	12V	15V	24V
RATED CURRENT	7.5A	6.5A	4.2A
CURRENT RANGE	0 ~ 7.5A	0 ~ 6.5A	0 ~ 4.2A
RATED POWER	90W	97.5W	100.8W
RIPPLE & NOISE (max)	120mVp-p	120mVp-p	150mVp-p
Ripple & noise are measured at 20MHz of bandwidth by using a 12 twisted pair-wire terminated with a 0.1µF & 47µF parallel capacitor.			
VOLTAGE ADJ. RANGE	12 ~ 15V	15 ~ 18V	24 ~ 29V
VOLTAGE TOLERANCE	±2.0%	±1.0%	±1.0%
Tolerance: includes set up tolerance, line regulation and load regulation.			
LINE REGULATION	±1.0%	±1.0%	±1.0%
LOAD REGULATION	±1.0%	±1.0%	±1.0%
SETUP, RISE TIME	2700ms, 80ms / 230VAC	2700ms, 80ms / 115VAC at full load	
HOLD UP TIME (Typ.)	50ms / 230VAC	18ms / 115VAC at full load	
VOLTAGE RANGE	88 ~ 264VAC	124 ~ 370VDC [Connect AC/L(+), AC/N(-)]	
FREQUENCY RANGE	47 ~ 63Hz		
EFFICIENCY (Typ.)	87%	87%	89%
AC CURRENT (max.)	3A / 115VAC	1.6A / 230VAC	
INRUSH CURRENT (Typ.)	COLD START 30A / 115VAC; 45A / 230VAC		
OVERLOAD	105 ~ 135% rated output power Protection type: Constant current limiting recovers automatically after fault condition is removed Under short circuit or overload ≥ 150% conditions, output voltage may shut down for 5 sec. and then go into constant current protection mode		
OVERVOLTAGE	16 ~ 20V	19 ~ 23V	30 ~ 35V
OVERTEMPERATURE	90°C ± 15°C (RTH2) detect on heat sink of power transistor Protection type: Shut down overvoltage, re-power on to recover		
WORKING TEMP.	-20 ~ +60°C (Refer to output load derating curve)		
WORKING HUMIDITY	20 ~ 90% RH non-condensing		
STORAGE TEMP., HUMIDITY	-40 ~ +85°C, 10 ~ 95% RH		
TEMP. COEFFICIENT	±0.03% / °C (0 ~ 50°C)		
VIBRATION	10 ~ 500Hz, 2G 10min. / 1cycle, 60 min. each long X,Y, Z axes		
MOUNTING	Compliance to IEC60068-2-6		
SAFETY STANDARDS	UL60950-1 EN60950-1 compliant Design refer to EN50178		
WITHSTAND VOLTAGE	I/P-O/P: 3KVAC		
ISOLATION RESISTANCE	I/P-O/P: 100M Ohms/500VDC (25°C; 70% RH)		
EMI CONDUCTION & RADIATION	Compliance to EN61204-3; EN55022 (CISPR22) Class B		
HARMONIC CURRENT	Compliance to EN61000-3-2,-3 Harmonic current test @ 90% load		
EMS IMMUNITY	Compliance to EN61000-4-2,3,4,5,6,8,11; ENV50204; EN55024; EN61000-6-2; EN61204-3; heavy industry level; criteria A The power supply is considered a component which will installed into a final equipment. The final equipment must be re-confirmed that it still meets EMC directives.		
MTBF	486K hrs min. MIL-HDBK-217K (25°C)		
DIMENSION	100x93x56mm (WxHxD)		
PACKING	0.35Kg; 36pcs / 13.6Kg / 0.89CUFT		
NOTE	All parameters NOT specially mentioned are measured at 230V AC input, rated load and 25°C of ambient temperature.		

For the latest on Altech Power Supply specifications please visit www.altechcorp.com/power.

Mechanical Specification

Terminal Pin. No Assignment

Pin No.	Assignment	Pin No.	Assignment
1	AC/L	5,6	-V
2	AC/N	7	LED
3,4	+V	8	+V ADJ.

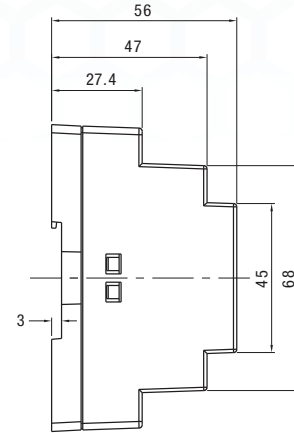
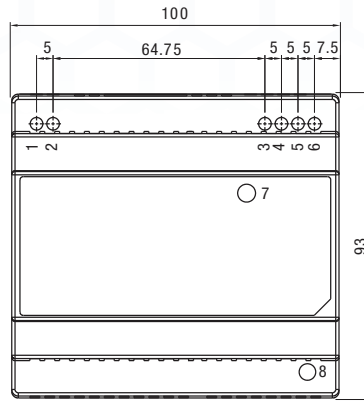

Block Diagram

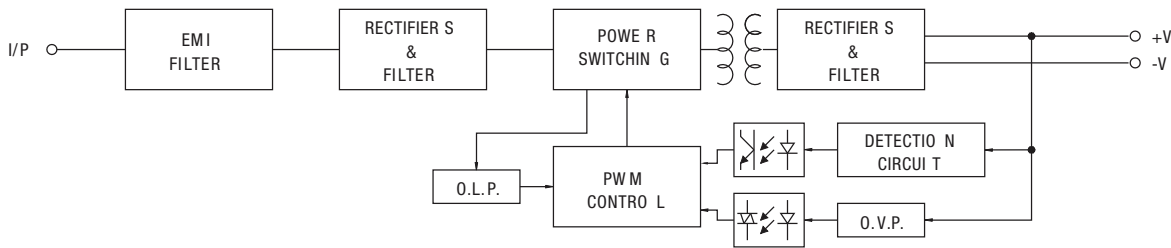

Derating Curve

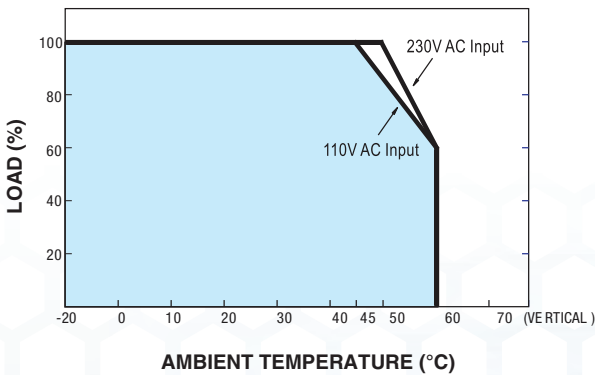

Output Derating VS Input Voltage

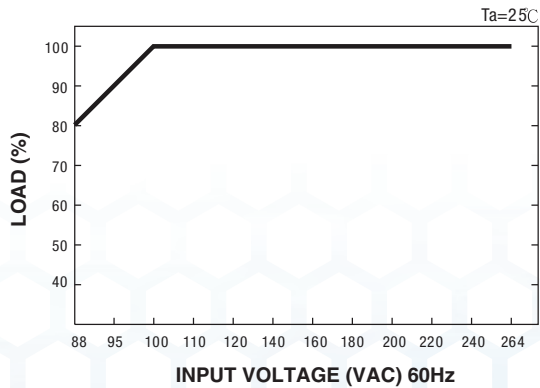

Note: All dimensions are in millimeters, to convert to inches multiply by 0.03937.

- PSC Class 2 Series Compact Housing
- PSA Flex Series 1 Phase
- PSB Flex Series 2 & 3 Phase
- PS-S Slim Series Plastic Housing
- PS Low Profile Series Plastic Housing
- PS Industrial Series 1, 2 & 3 Phase
- PS C & W Series 1 and 2 Phase
- CBI Type DC UPS Systems
- CB Type Battery Chargers
- Accessories
- Appendix



Компания «ЭлектроПласт» предлагает заключение долгосрочных отношений при поставках импортных электронных компонентов на взаимовыгодных условиях!

Наши преимущества:

- Оперативные поставки широкого спектра электронных компонентов отечественного и импортного производства напрямую от производителей и с крупнейших мировых складов;
- Поставка более 17-ти миллионов наименований электронных компонентов;
- Поставка сложных, дефицитных, либо снятых с производства позиций;
- Оперативные сроки поставки под заказ (от 5 рабочих дней);
- Экспресс доставка в любую точку России;
- Техническая поддержка проекта, помощь в подборе аналогов, поставка прототипов;
- Система менеджмента качества сертифицирована по Международному стандарту ISO 9001;
- Лицензия ФСБ на осуществление работ с использованием сведений, составляющих государственную тайну;
- Поставка специализированных компонентов (Xilinx, Altera, Analog Devices, Intersil, Interpoint, Microsemi, Aeroflex, Peregrine, Syfer, Eurofarad, Texas Instrument, Miteq, Cobham, E2V, MA-COM, Hittite, Mini-Circuits, General Dynamics и др.);

Помимо этого, одним из направлений компании «ЭлектроПласт» является направление «Источники питания». Мы предлагаем Вам помощь Конструкторского отдела:

- Подбор оптимального решения, техническое обоснование при выборе компонента;
- Подбор аналогов;
- Консультации по применению компонента;
- Поставка образцов и прототипов;
- Техническая поддержка проекта;
- Защита от снятия компонента с производства.



Как с нами связаться

Телефон: 8 (812) 309 58 32 (многоканальный)

Факс: 8 (812) 320-02-42

Электронная почта: org@eplast1.ru

Адрес: 198099, г. Санкт-Петербург, ул. Калинина, дом 2, корпус 4, литера А.