

# LC898217XC

## Auto Focus (AF) Controller & Driver



**ON Semiconductor®**

[www.onsemi.com](http://www.onsemi.com)

### 1. Overview

LC898217XC is an AF control LSI. It consists of 1 system of feedback circuit for AF control.

### 2. Features

- Built-in equalizer circuit using digital operation
  - AF control equalize circuit
  - Any coefficient can be specified by 2-wire serial I/F (TWIF)
- 2-wire serial interface  
(The communication protocol is compatible with I<sup>2</sup>C.)
- Built-in A/D converter
  - Input 1 channel
- Built-in D/A converter
  - Output 2 channel (Hall offset, Constant current bias)
- Built-in VGA
  - Hall Amp
  - 1 channel
- Built-in EEPROM
  - 128 byte (16 byte/page)
- Built-in OSC
- Built-in Constant Current Driver
  - 110 mA
  - 1 channel
- Package
  - WL-CSP 10-pin
  - Pb-Free, Halogen Free
- Supply voltage
  - V<sub>DD</sub> (2.6 V to 3.3 V)

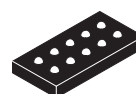

WLCSP10, 1.04x2.04

### ORDERING INFORMATION

See detailed ordering and shipping information on page 9 of this data sheet.

### 3. Pin Description

TYPE					
I	INPUT	P	Power supply, GND	NC	NOT CONNECT
O	OUTPUT				
B	BIDIRECTION				

■ 2-wire serial interface

SCL	I	2-wire serial interface clock pin
SDA	B	2-wire serial interface data pin

■ Hall interface

BIASO	O	D/A output (to Hall element)
OPINP	I	VGA input (from Hall element)
OPINM	I	VGA input (from Hall element)

■ Driver interface

OUT1	O	Driver output (to Actuator)
OUT2	O	Driver output (to Actuator)

■ Power supply pin

VDD	P	Power supply
VSS	P	GND

■ Test pin

PORT	B	Analog test signal input/output Convergence detection monitor output VSYNC input
------	---	--

\* Process when pins are not used

PIN TYPE "O" – Ensure that it is set to OPEN.

PIN TYPE "I" – OPEN is inhibited. Ensure that it is connected to the VDD or VSS even when it is unused.

(Please contact ON Semiconductor for more information about selection of VDD or VSS.)

PIN TYPE "B" – If you are unsure about processing method on the pin description of pin layout table, please contact us.

Note that incorrect processing of unused pins may result in defects.

\* In case of connecting PORT pin with HOST CPU

When LC898217XC is power off and HOST CPU is power on, a HOST CPU pin connected with PORT pin have to be fixed "L" level.

# LC898217XC

## 4. Pin Layout

Circuit Name	Number of PINs	Circuit Name	Number of PINs
Analog	4	Driver	2
Logic	2	Power	2

“PORT” pin has analog function and digital function.

### BOTTOM VIEW

	A	B
1	OUT2	OUT1
2	VSS	VDD
3	PORT	SCL
4	BIASO	SDA
5	OPINM	OPINP

# LC898217XC

## 5. Block Diagram

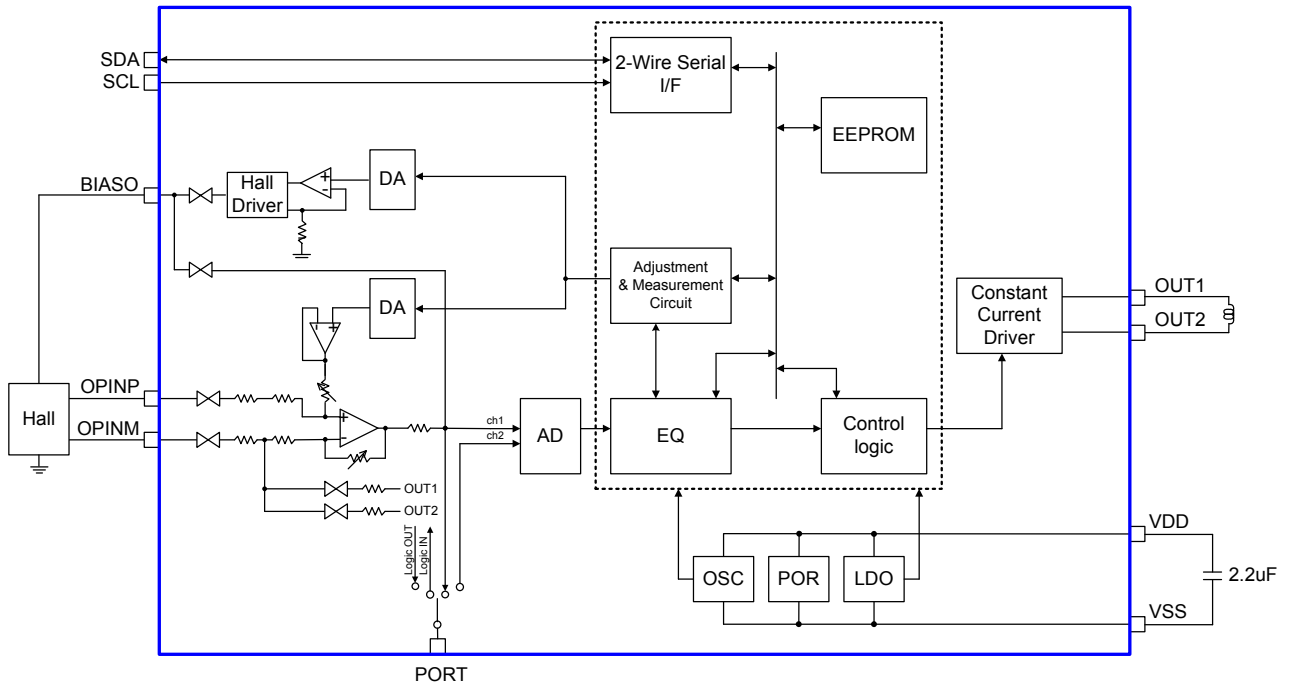

6. Package Dimensions

unit : mm

WLCSP10, 1.04x2.04

CASE 567LF  
ISSUE B

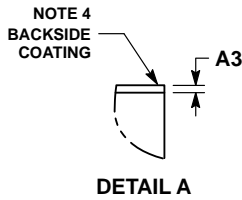
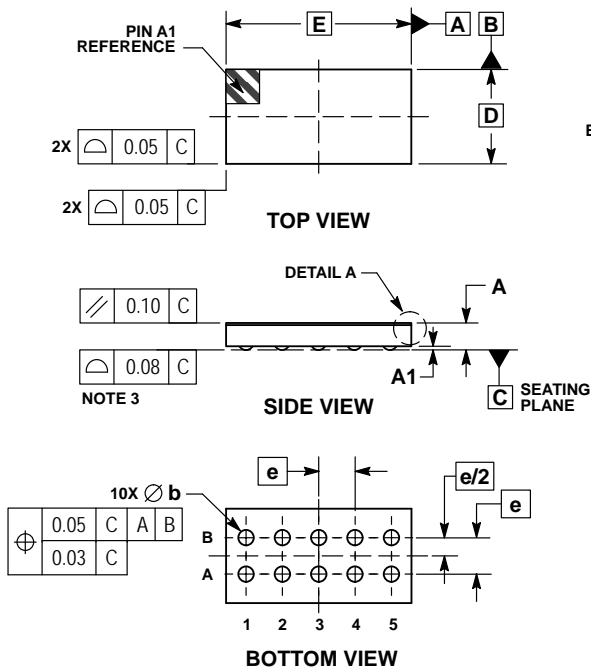

NOTES:

1. DIMENSIONING AND TOLERANCING PER ASME Y14.5M, 1994.
2. CONTROLLING DIMENSION: MILLIMETERS.
3. COPLANARITY APPLIES TO THE SPHERICAL CROWNS OF THE SOLDER BALLS.
4. BACKSIDE COATING IS OPTIONAL.

DIM	MILLIMETERS	
	MIN	MAX
A	0.27	0.33
A1	0.04 REF	
A3	0.025 REF	
b	0.12	0.22
D	1.04 BSC	
E	2.04 BSC	
e	0.40 BSC	

**RECOMMENDED SOLDERING FOOTPRINT\***

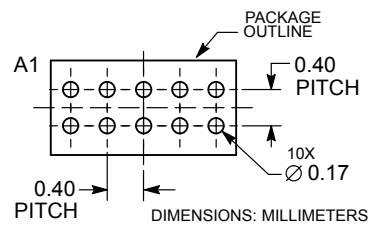

\*For additional information on our Pb-Free strategy and soldering details, please download the ON Semiconductor Soldering and Mounting Techniques Reference Manual, SOLDERRM/D.

7. Electrical Characteristics

1) Absolute Maximum Rating at  $V_{SS} = 0\text{ V}$

Item	Symbol	Condition	Rating	Unit
Supply voltage	$V_{DD33\text{ max}}$	$T_a \leq 25^\circ\text{C}$	-0.3 to 4.6	V
Input/output voltage	$V_{I33}, V_{O33}$	$T_a \leq 25^\circ\text{C}$	-0.3 to $V_{DD33}+0.3$	V
Storage ambient temperature	Tstg		-55 to 125	$^\circ\text{C}$
Operating ambient temperature	Topr		-30 to 70	$^\circ\text{C}$

Stresses exceeding those listed in the Maximum Ratings table may damage the device. If any of these limits are exceeded, device functionality should not be assumed, damage may occur and reliability may be affected.

2) Allowable Operating Ratings at  $T_a = -30$  to  $70^\circ\text{C}$ ,  $V_{SS} = 0\text{ V}$

3 V power supply ( $V_{DD}$ )

Item	Symbol	Min	Typ	Max	Unit
Supply voltage	$V_{DD33}$	2.6	2.8	3.3	V
Input voltage range	$V_{IN}$	0		$V_{DD33}$	V

Functional operation above the stresses listed in the Recommended Operating Ranges is not implied. Extended exposure to stresses beyond the Recommended Operating Ranges limits may affect device reliability.

3) DC Characteristics : Input/Output level at  $V_{SS} = 0\text{ V}$ ,  $V_{DD} = 2.6$  to  $3.6\text{ V}$ ,  $T_a = -30$  to  $70^\circ\text{C}$

Item	Symbol	Condition	Min	Typ	Max	Unit	Applicable pins
High-level input voltage	$V_{IH}$	CMOS compliant Schmidt	1.4			V	SCL, SDA, PORT
Low-level input voltage	$V_{IL}$				0.4	V	
High-level output voltage	$V_{OH}$	IOL = -2 mA	$V_{DD}-0.4$			V	PORT
Low-level output voltage	$V_{OL}$	IOL = 2 mA			0.4	V	SDA, PORT
Pulldown resistor	Rdn		50		220	k $\Omega$	PORT

Product parametric performance is indicated in the Electrical Characteristics for the listed test conditions, unless otherwise noted. Product performance may not be indicated by the Electrical Characteristics if operated under different conditions.

4) Driver output (OUT1, OUT2) at  $V_{SS} = 0\text{ V}$ ,  $V_{DD} = 2.8\text{ V}$ ,  $T_a = 25^\circ\text{C}$

Item	Symbol	Condition	Min	Typ	Max	Unit	Applicable pins
Maximum current	I <sub>full</sub>		105		115	mA	OUT1, OUT2
Output leak current	I <sub>oleak</sub>			1		$\mu\text{A}$	

5) Non-volatile Memory Characteristics

Item	Symbol	Condition	Min	Typ	Max	Unit	Applicable circuit
Endurance	EN				1000	Cycles	EEPROM
Data retention	RT		10			Years	
Write time	t <sub>WT</sub>				20	ms	

8. AC Characteristics

8.1 VDD supply timing

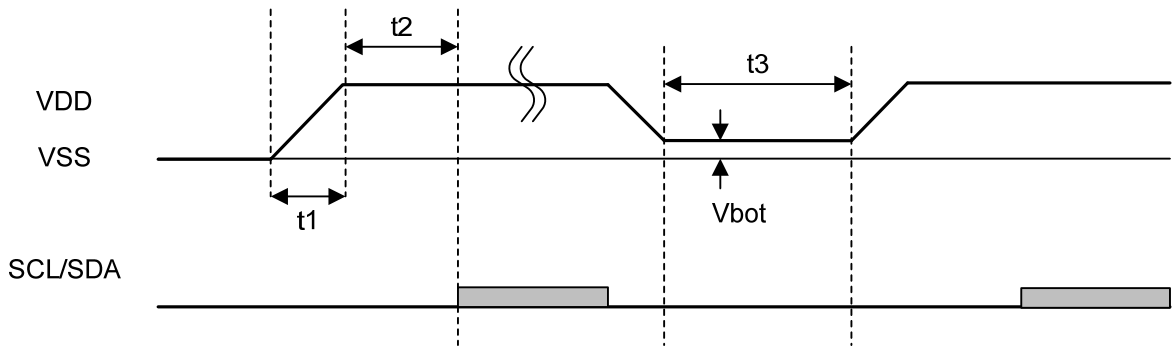

Figure 8.1 VDD supply timing

It is available to use 2-wire serial interface 5 ms later for Power On Reset of VDD.

Item	Symbol	Min	Typ	Max	Unit
VDD turn on time	t1			3	ms
2-wire serial interface start time from VDD on	t2	5			ms
VDD off time	t3	100			ms
Bottom Voltage	Vbot			0.1	V

8.2 AC specification

Figure 8.2 shows interface timing definition and Table 8.1 shows electric characteristics.

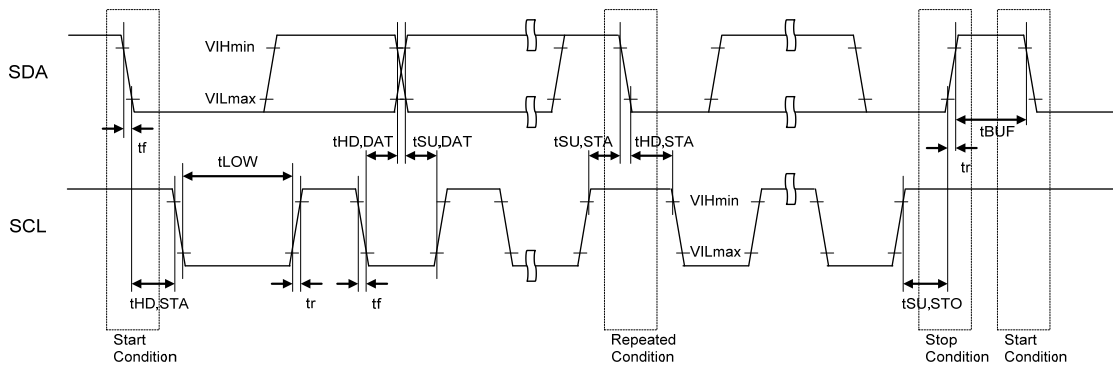

Figure 8.2 2-wire serial interface timing definition

Table 8.1 Electric characteristics for 2-wire serial interface (AC characteristics)

Item	Symbol	Pin name	Fast-mode			Fast-mode Plus			Unit
			Min	Typ	Max	Min	Typ	Max	
SCL clock frequency	FSCL	SCL			400			1000	kHz
START condition hold time	tHD, STA	SCL SDA	0.6			0.26			μs
SCL clock Low period	tLOW	SCL	1.3			0.5			μs
SCL clock High period	tHIGH	SCL	0.6			0.26			μs
Setup time for repetition START condition	tSU, STA	SCL SDA	0.6			0.26			μs
Data hold time	tHD, DAT	SCL SDA	0 (*3)		0.9	0 (*3)			μs
Data setup time	tSU, DAT	SCL SDA	100			50			ns
SDA, SCL rising time	tr	SCL SDA			300			120	ns
SDA, SCL falling time	tf	SCL SDA			300			120	ns
STOP condition setup time	tSU, STO	SCL SDA	0.6			0.26			μs
Bus free time between STOP and START	tBUF	SCL SDA	1.3			0.5			μs

\*3: LC898217XC is designed for a condition with typ. 20 ns of hold time. If SDA signal is unstable around falling point of SCL signal, please implement an appropriate treatment on board, such as inserting a resistor.



# LC898217XC

## ORDERING INFORMATION

Device	Package	Shipping (Qty / Packing)
LC898217XC-MH	WLCSP10, 1.04x2.04 (Pb-Free / Halogen Free)	4000 / Tape & Reel

† For information on tape and reel specifications, including part orientation and tape sizes, please refer to our Tape and Reel Packaging Specifications Brochure, BRD8011/D. [http://www.onsemi.com/pub\\_link/Collateral/BRD8011-D.PDF](http://www.onsemi.com/pub_link/Collateral/BRD8011-D.PDF)

ON Semiconductor and the ON Semiconductor logo are trademarks of Semiconductor Components Industries, LLC dba ON Semiconductor or its subsidiaries in the United States and/or other countries. ON Semiconductor owns the rights to a number of patents, trademarks, copyrights, trade secrets, and other intellectual property. A listing of ON Semiconductor's product/patent coverage may be accessed at [www.onsemi.com/site/pdf/Patent-Marking.pdf](http://www.onsemi.com/site/pdf/Patent-Marking.pdf). ON Semiconductor reserves the right to make changes without further notice to any products herein. ON Semiconductor makes no warranty, representation or guarantee regarding the suitability of its products for any particular purpose, nor does ON Semiconductor assume any liability arising out of the application or use of any product or circuit, and specifically disclaims any and all liability, including without limitation special, consequential or incidental damages. Buyer is responsible for its products and applications using ON Semiconductor products, including compliance with all laws, regulations and safety requirements or standards, regardless of any support or applications information provided by ON Semiconductor. "Typical" parameters which may be provided in ON Semiconductor data sheets and/or specifications can and do vary in different applications and actual performance may vary over time. All operating parameters, including "Typicals" must be validated for each customer application by customer's technical experts. ON Semiconductor does not convey any license under its patent rights nor the rights of others. ON Semiconductor products are not designed, intended, or authorized for use as a critical component in life support systems or any FDA Class 3 medical devices or medical devices with a same or similar classification in a foreign jurisdiction or any devices intended for implantation in the human body. Should Buyer purchase or use ON Semiconductor products for any such unintended or unauthorized application, Buyer shall indemnify and hold ON Semiconductor and its officers, employees, subsidiaries, affiliates, and distributors harmless against all claims, costs, damages, and expenses, and reasonable attorney fees arising out of, directly or indirectly, any claim of personal injury or death associated with such unintended or unauthorized use, even if such claim alleges that ON Semiconductor was negligent regarding the design or manufacture of the part. ON Semiconductor is an Equal Opportunity/Affirmative Action Employer. This literature is subject to all applicable copyright laws and is not for resale in any manner.



Компания «ЭлектроПласт» предлагает заключение долгосрочных отношений при поставках импортных электронных компонентов на взаимовыгодных условиях!

Наши преимущества:

- Оперативные поставки широкого спектра электронных компонентов отечественного и импортного производства напрямую от производителей и с крупнейших мировых складов;
- Поставка более 17-ти миллионов наименований электронных компонентов;
- Поставка сложных, дефицитных, либо снятых с производства позиций;
- Оперативные сроки поставки под заказ (от 5 рабочих дней);
- Экспресс доставка в любую точку России;
- Техническая поддержка проекта, помощь в подборе аналогов, поставка прототипов;
- Система менеджмента качества сертифицирована по Международному стандарту ISO 9001;
- Лицензия ФСБ на осуществление работ с использованием сведений, составляющих государственную тайну;
- Поставка специализированных компонентов (Xilinx, Altera, Analog Devices, Intersil, Interpoint, Microsemi, Aeroflex, Peregrine, Syfer, Eurofarad, Texas Instrument, Miteq, Cobham, E2V, MA-COM, Hittite, Mini-Circuits, General Dynamics и др.);

Помимо этого, одним из направлений компании «ЭлектроПласт» является направление «Источники питания». Мы предлагаем Вам помощь Конструкторского отдела:

- Подбор оптимального решения, техническое обоснование при выборе компонента;
- Подбор аналогов;
- Консультации по применению компонента;
- Поставка образцов и прототипов;
- Техническая поддержка проекта;
- Защита от снятия компонента с производства.



#### Как с нами связаться

**Телефон:** 8 (812) 309 58 32 (многоканальный)

**Факс:** 8 (812) 320-02-42

**Электронная почта:** [org@eplast1.ru](mailto:org@eplast1.ru)

**Адрес:** 198099, г. Санкт-Петербург, ул. Калинина, дом 2, корпус 4, литера А.