

Automotive Grade GPS/Galileo/Glonass/QZSS receiver

Data brief

**Features**

- STMicroelectronics® 3rd generation positioning receiver with 32 Tracking channels and 2 fast acquisition channels compatible with GPS, Galileo and Glonass systems
- Embedded RF Front-End with separate GPS/Galileo/QZSS and Glonass IF outputs
- Embedded low noise amplifier
- -162 dBm indoor sensitivity (tracking mode)
- Fast TTFF <1 s in Hot start and 35s in Cold Start
- High performance ARM946 MCU (up to 208 MHz)
- 256 Kbyte embedded SRAM
- Real Time Clock (RTC) circuit
- 32-bit Watch-dog timer
- 2 UARTs
- 1 I²C master/slave interface
- 1 External SQI Flash interface
- USB2.0 dual-role full speed (12 MHz) with integrated physical layer transceiver
- 2 Controller Area Network (CAN)
- 3 channels ADC (10 bits)
- 3 Embedded 1.8 V voltage regulators
- I/O level selectable 1.8 V or 3.3 V

- Operating condition:
 - V_{DD12}: 1.2 V ±10%
 - V_{DD18/RF18}: 1.8 V ±5%
 - V_{LPVR} 1.62 V to 3.6 V
 - V_{ddIO}: 1.8 V ±5%; 3.3 V ±10%
- ST Automotive Grade compliant
- Package:
 - VFQFPN56 (7x7x0.85 mm) 0.4 mm Pitch
- Ambient temperature range: -40/+85°C

Description

STA8088GA is a single die standalone positioning receiver IC working on multiple constellations (GPS/Galileo/Glonass/QZSS).

The device is compliant with ST Automotive Grade which in addition to AEC-Q100 qualification includes a set of production flow methodology targeting zero defect per million.

STA8088GA, fulfilling high quality and service level Automotive market requirements, is the ideal solution for in-dash navigation and OEM telematic application.

The device is offered with a complete GNSS firmware which performs all GNSS operations including tracking, acquisition, navigation and data output.

Contents

- 1 Overview 5**
- 2 Pin description 6**
 - 2.1 Block diagram 6
 - 2.2 VFQFPN56 pin configuration 7
 - 2.3 Power supply pins 8
 - 2.4 Main function pins 9
 - 2.5 Test/emulated dedicated pins 10
 - 2.6 RF front-end pins 10
 - 2.7 Port 0 pins 10
 - 2.8 Port 1 pins 11
- 3 Package and packing information 13**
 - 3.1 ECOPACK® packages 13
 - 3.2 VFQFPN56 package information 13
- 4 Ordering information 15**
- 5 Revision history 16**

List of tables

Table 1.	Power supply pins	8
Table 2.	Main function pins	9
Table 3.	Test/emulated dedicated pins	10
Table 4.	RF front-end pins	10
Table 5.	Port 0 pins	11
Table 6.	Port 1 pins	11
Table 7.	VFQFPN56 7 x 7 x 0.85 mm package dimensions	13
Table 8.	Document revision history	16

List of figures

Figure 1.	STA8088GA system block diagram	6
Figure 2.	VFQFPN56 connection diagram - Automotive Grade (with CAN) (bottom view)	7
Figure 3.	VFQFPN56 connection diagram - no CAN (bottom view).	8
Figure 4.	VFQFPN56 package dimension	14
Figure 5.	Ordering information scheme	15

1 Overview

STA8088GA is a highly integrated System-On-Chip device designed for positioning systems applications.

It combines the high performance of ARM946 microprocessor with embedded enhanced peripherals and I/O capabilities with ST next generation triple-constellation positioning engine. The RF Front-End and Base Band processors are able to support GPS/Galileo and Glonass navigation systems. The device is offered with a complete firmware which performs all positioning operations including tracking, acquisition, navigation and data output with no need of external memories.

It also provides clock generation via PLL, backup logic with real time clock and it supports USB2.0 standard at full speed, (12 Mbps) with on-chip PHY.

STA8088GA is software compatible with the ARM processor family. The device is power supplied with 1.8 V and uses three on-chip voltage regulators to internally supply the RF front-End, core logic and the backup logic. In order to reduce the power consumption the chips can be directly powered with 1.2V bypassing the embedded voltage regulators which will be put in power down mode.

I/O lines are compatible with 1.8V and 3.3V.

STA8088GA, using STMicroelectronics CMOSRF Technology, is housed in VFQFPN56 (7 x 7 x 0.85 mm) package.

STA8088GA is compliant with ST Automotive Grade which in addition to AEC-Q100 qualification includes a set of production flow methodology targeting zero defect per million.

STA8088GA, fulfilling high quality and service level Automotive market requirements, is the ideal solution for in-dash navigation and OEM telematic application.

2 Pin description

2.1 Block diagram

Figure 1. STA8088GA system block diagram

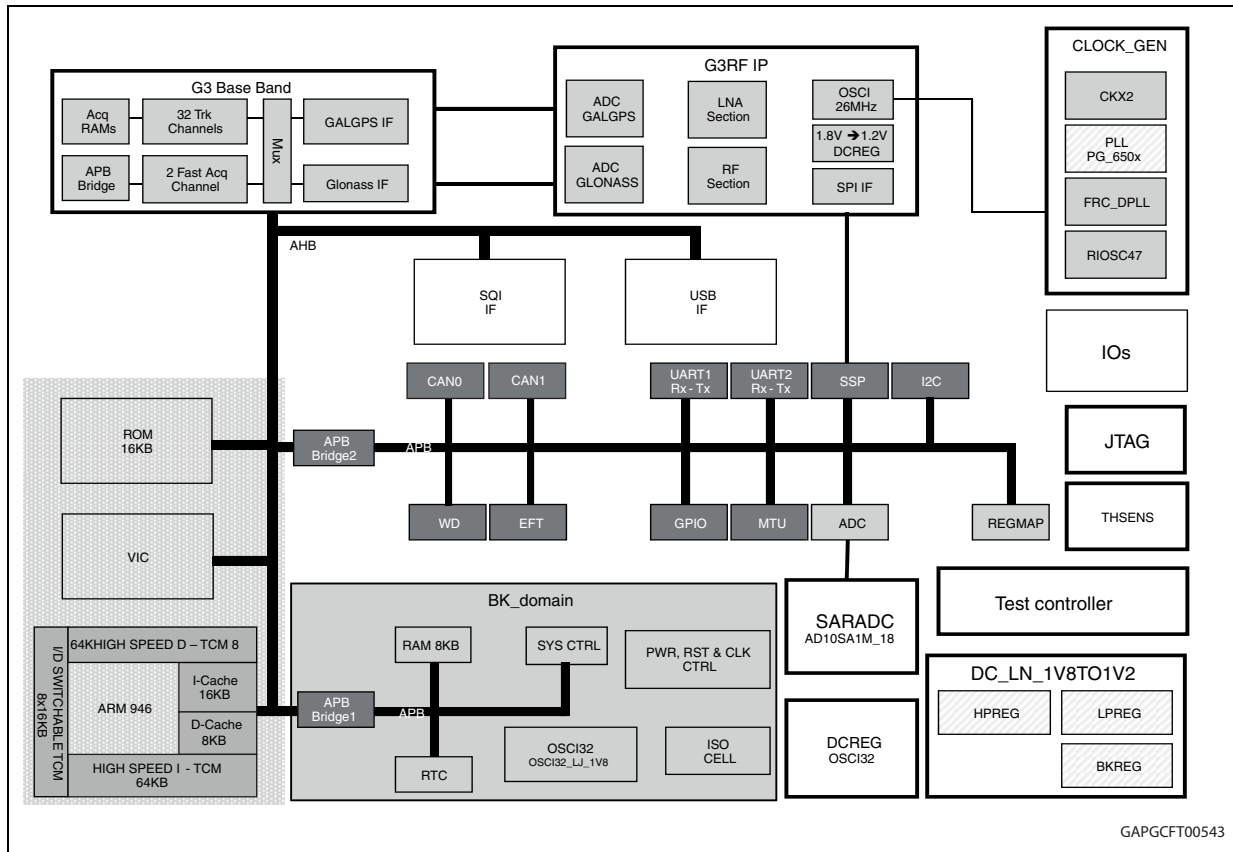

2.2 VFQFPN56 pin configuration

Figure 2. VFQFPN56 connection diagram - Automotive Grade (with CAN) (bottom view)

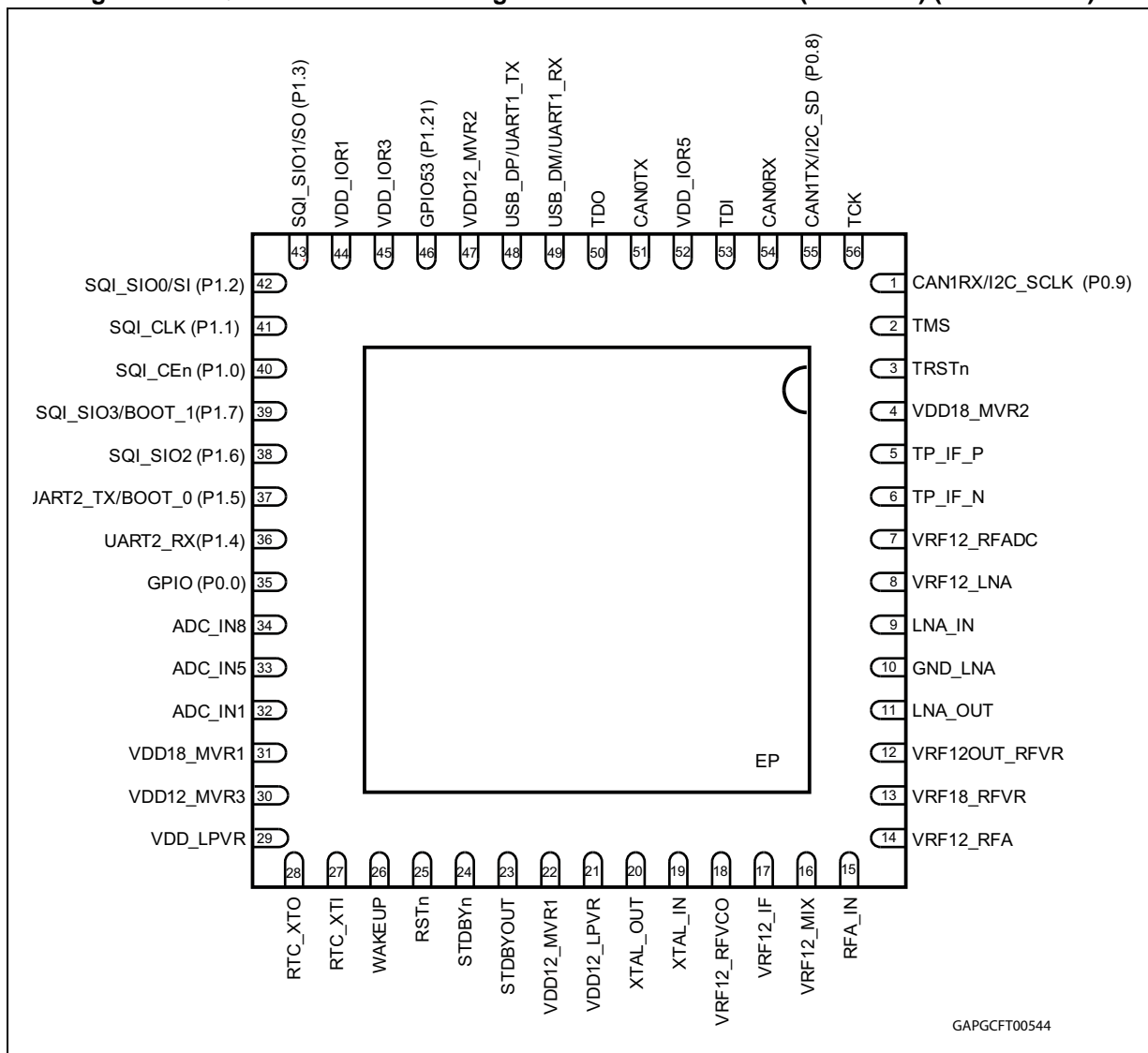
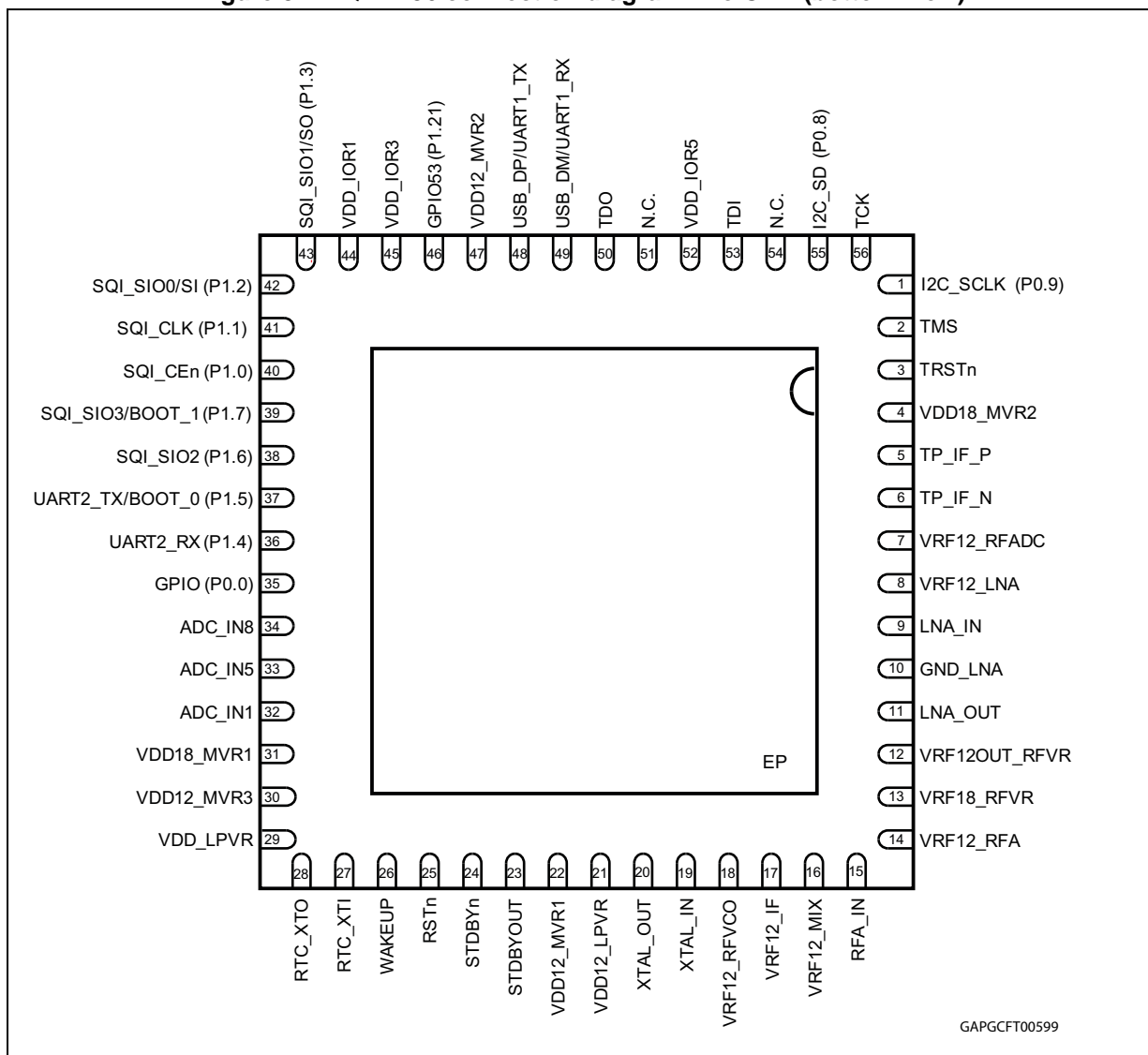

Figure 3. VFQFPN56 connection diagram - no CAN (bottom view)



2.3 Power supply pins

Table 1. Power supply pins

Symbol	I/O	Functions	VFQFN56
VDD18_MVR[1,2]	Pwr	Digital supply voltage for main voltage regulator (1.8 V)	31,4
VDD12_MVR[1,2,3]	Pwr	Digital supply voltage for core circuitry (1.2 V). When using the MVR, this pin shall not be driven by an external voltage supply, but a capacitance shall be connected between these pins and GND to guarantee on-chip voltage stability.	22,47,30
VDD_LPVR	Pwr	Digital supply voltage for low power voltage regulator (1.62 - 3.6 V)	29

Table 1. Power supply pins (continued)

Symbol	I/O	Functions	VFQFN56
VDD12_LPVR	Pwr	Digital supply voltage for backup logic (1.2 V). When using the LPVR, this pin shall not be driven by an external voltage supply, but a capacitance shall be connected between these pins and GND to guarantee on-chip voltage stability.	21
VDD_IOR1	Pwr	Digital supply voltage for I/O ring 1 (1.8 or 3.3 V)	44
VDD_IOR3	Pwr	Digital supply voltage for I/O ring 3 (1.8 V)	45
VDD_IOR5	Pwr	Digital supply voltage for I/O ring 5 (3.3 V)	52
VRF18_RFVR	Pwr	Analog supply voltage for RF voltage regulator (1.8 V)	13
VRF12OUT_RFVR	Pwr	RF voltage regulator 1.2 V output	12
VRF12_LNA	Pwr	Analog supply voltage for LNA (1.2 V)	8
VRF12_RFA	Pwr	Analog supply voltage for RFA (1.2 V)	14
VRF12_MIX	Pwr	Analog supply voltage for Mixer (1.2 V)	16
VRF12_IF	Pwr	Analog supply voltage for IF (1.2 V)	17
VRF12_RFVCO	Pwr	Analog supply voltage for VCO (1.2 V)	18
VRF12_RFADC	Pwr	Analog supply voltage for RF ADC (1.2 V)	7
GND_LNA	GND	Analog supply ground for LNA	10
GND	GND	Analog and digital supply ground	EP

2.4 Main function pins

Table 2. Main function pins

Symbol	I/O voltage	I/O	Functions	VFQFPN56
STDBYn	1.2V	I	When low, the chip is forced in Standby Mode - All pins in high impedance except the ones powered by Backup supply	24
STDBYOUT	1.2V	O	When low, indicates the chip is in Standby Mode.	23
RSTn ⁽¹⁾	1.2V	I	Reset Input with Schmitt-Trigger characteristics and noise filter.	25
WAKEUP ⁽²⁾	1.2V	I	WAKEUP from STANDBY mode	26
RTC_XTI	1.5V (Max)	I	Input of the 32KHz oscillator amplifier circuit and input of the internal real time clock circuit.	27
RTC_XTO	1.5V (Max)	O	Output of the oscillator amplifier circuit.	28
ADC_IN[1,5,8]	1.4V – 0 Typ Range	I	ADC Analog input [1,5,8]	32,33, 34
USB_DP/UART1_TX	VDD_IOR5	USB/O	USB D+ signal / UART1 Tx data	48
USB_DM/UART1_RX	VDD_IOR5	USB/I	USB D- signal / UART1 Rx data	49

Table 2. Main function pins (continued)

Symbol	I/O voltage	I/O	Functions	VFQFPN56
CAN0TX ⁽³⁾	VDD_IOR5	O	CAN0 - transmit data output	51
CAN0RX ⁽³⁾	VDD_IOR5	I	CAN0 - receive data input	54

1. When RSTn is de-asserted, pin WAKEUP must be low.
2. The WAKEUP pulse must be longer than 500 μ s.
3. Only for Automotive Grade devices (STA8088GA, STA8088A).

2.5 Test/emulated dedicated pins

Table 3. Test/emulated dedicated pins

Symbol	I/O voltage	I/O	Functions	VFQFPN56
TDO	VDD_IOR5	O	JTAG test data out	50
TDI	VDD_IOR5	I	JTAG test data in	53
TCK	VDD_IOR5	I	JTAG test clock	56
TMS	VDD_IOR5	I	JTAG test mode select	2
TRSTn ⁽¹⁾	VDD_IOR5	I	JTAG test circuit reset	3
TP_IF_P	VRF12_IF	O	Diff. test point for IF – positive	5
TP_IF_N	VRF12_IF	O	Diff. test point for IF – negative	6

1. If JTAG interface is not used, pin TRSTn must be asserted low.

2.6 RF front-end pins

Table 4. RF front-end pins

Symbol	I/O voltage	I/O	Functions	VFQFPN56
LNA_IN	VRF12_LNA	I	Low noise amplifier input	9
LNA_OUT	VRF12_LNA	O	Low noise amplifier output	11
RFA_IN	VRF12_RFA	I	RF amplifier input	15
XTAL_IN	VRF12_RFDig	I	Input side of crystal oscillator or TCXO input	19
XTAL_OUT	VRF12_RFDig	O	Output side of crystal oscillator	20

2.7 Port 0 pins

Port 0 consists of a 32-bit bidirectional I/O port (only 3-bit are used in STA8088GA).

It can be either used as general purpose Input or Output port, or configured according to the associated alternate functions.

Table 5. Port 0 pins

Symbol	I/O voltage	I/O	Mode	Functions	VFQFPN56
P0.0	VDD_IOR1	O	Default	GPIO.0: General Purpose IO	35
		I	A	PPS_IN: Pulse Per Second Input	
		O	B	PPS_OUT: Pulse Per Second Output	
P0.8	VDD_IOR5	O	Default	CAN1TX ⁽¹⁾ : CAN1 Transmit Data Output	55
		IO	A	GPIO.8: General Purpose IO	
		IO	B	I2C_SD: I2C Serial Data	
P0.9	VDD_IOR5	I	Default	CAN1RX ⁽¹⁾ : CAN1 Receive Data Input	1
		IO	A	GPIO.9: General Purpose IO	
		O	B	I2C_SCLK: I2C Clock	

1. Only for Automotive Grade devices (STA8088GA, STA8088A).

2.8 Port 1 pins

Port 1 consists of a 32-bit bidirectional I/O port (only 9-bit are used in STA8088GA).

It can be either used as general purpose Input or Output port, or configured according to the associated alternate functions.

Table 6. Port 1 pins

Symbol	I/O Voltage	I/O	Mode	Functions	VFQFPN56
P1.0	VDD_IOR1	O	Default	SQI_CEN: SQI Flash chip enable	40
		I/O	A	GPIO32: general purpose I/O	
		I/O	B	SIGNGGPS: GGPS 3bit coding output (sign)	
P1.1	VDD_IOR1	O	Default	SQI_CLK: SQI Flash clock	41
		I/O	A	GPIO33: general purpose I/O	
		I/O	B	CLOCK_GGPS: GGPS clock out	
P1.2	VDD_IOR1	I/O	Default	SQI_SIO0/SI: SQI Flash data I/O 0 / ser. I	42
		I/O	A	GPIO34: general purpose I/O	
		I/O	B	SIGNGNS: GNS 3bit coding output (sign)	
P1.3	VDD_IOR1	I/O	Default	SQI_SIO1/SO: SQI Flash data I/O 1 / ser. O	43
		I/O	A	GPIO35: general purpose I/O	
		I/O	B	CLOCK_GNS: GNS clock out	
P1.4	VDD_IOR1	I	Default	UART2_RX: UART 2 Rx data	36
		I/O	A	GPIO36: general purpose I/O	

Table 6. Port 1 pins (continued)

Symbol	I/O Voltage	I/O	Mode	Functions	VFQFPN56
P1.5	VDD_IOR1	I/O	Default	UART2_TX / BOOT_0: UART 2 Tx data / ARM Boot 0	37
		I/O	A	GPIO37: general purpose I/O	
P1.6	VDD_IOR1	I/O	Default	SQI_SIO2: SQI Flash data I/O 2	38
		I/O	A	GPIO38: general purpose I/O	
P1.7	VDD_IOR1	I/O	Default	SQI_SIO3/BOOT_1: SQI Flash data I/O 3/ARMBoot 1	39
		I/O	A	GPIO39: general purpose I/O	
P1.21	VDD_IOR3	I/O	A	GPIO53: general purpose I/O	46

3 Package and packing information

3.1 ECOPACK[®] packages

In order to meet environmental requirements, ST offers these devices in different grades of ECOPACK[®] packages, depending on their level of environmental compliance. ECOPACK[®] specifications, grade definitions and product status are available at: www.st.com.

ECOPACK[®] is an ST trademark.

3.2 VFQFPN56 package information

Table 7. VFQFPN56 7 x 7 x 0.85 mm package dimensions

Symbol	Min.	Typ.	Max
Common dimensions			
A	0.80	0.85	0.90
A1	0	0.01	0.05
A2	0.60	0.65	0.70
A3	0.20 REF		
b	0.15	0.20	0.25
D	7.00 BSC		
D1	6.75 BSC		
D2	5.0	5.1	5.2
E	7.00 BSC		
E1	6.75 BSC		
E2	5.0	5.1	5.2
e	0.40 BSC		
θ	0°		12°
L	0.30	0.40	0.50
N	56		
Nd	14		
Ne	14		
P	0.24	0.42	0.60

Figure 4. VFQFPN56 package dimension

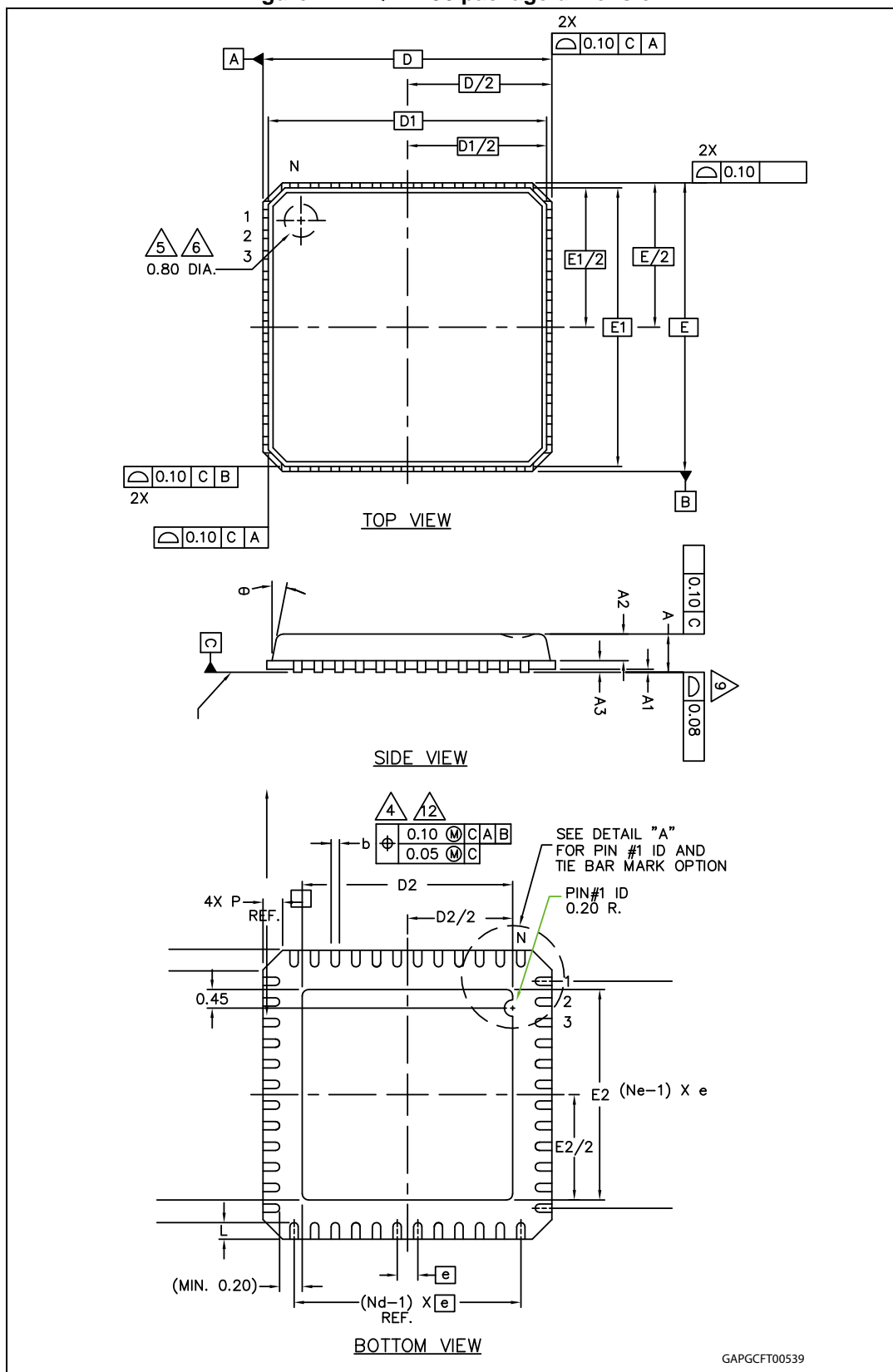

4 Ordering information

Figure 5. Ordering information scheme

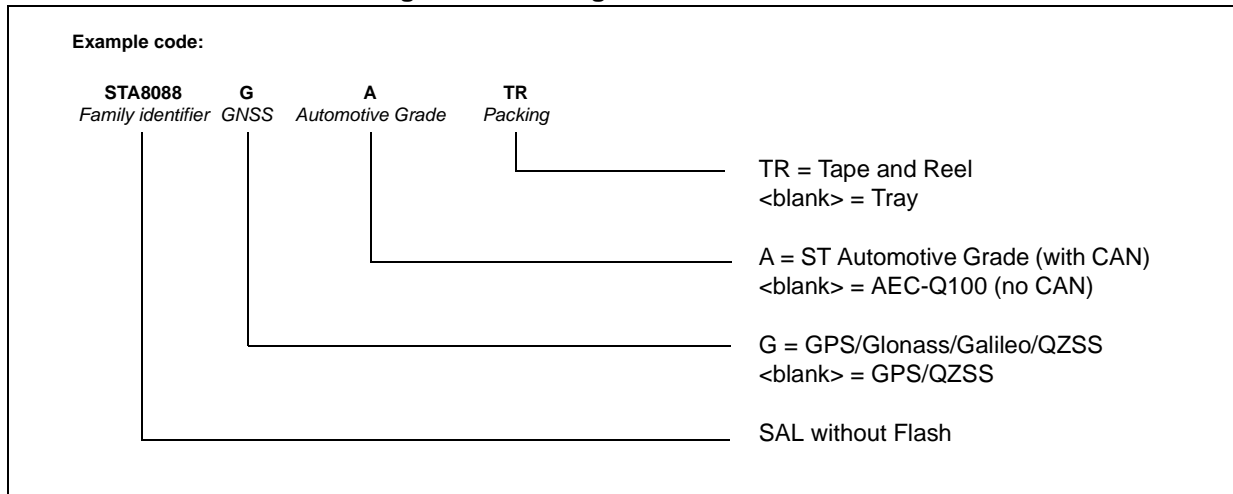

5 Revision history

Table 8. Document revision history

Date	Revision	Changes
17-Jan-2012	1	Initial release.
14-Mar-2012	2	Updated <i>Features</i> list <i>Table 2: Main function pins:</i> – USB_DP/UART1_TX, USB_DM/UART1_RX: updated I/O <i>Table 7: VFQFPN56 7 x 7 x 0.85 mm package dimensions:</i> – Q, R: removed rows Added <i>Table 8: VFQFPN56 8 x 8 x 0.85 mm package dimensions</i> Updated <i>Figure 5: Ordering information scheme</i>
16-Sep-2013	3	Updated Disclaimer.
14-Apr-2014	4	Updated <i>Description</i> .
23-Sep-2014	5	Updated <i>Features</i> list Updated <i>Chapter 1: Overview</i> <i>Table 2: Main function pins:</i> – RSTn, WATEUP: added note <i>Table 3: Test/emulated dedicated pins:</i> – TRSTn: added note Removed <i>Table 8: VFQFPN56 8 x 8 x 0.85 mm package dimensions</i> Updated <i>Figure 5: Ordering information scheme</i>

IMPORTANT NOTICE – PLEASE READ CAREFULLY

STMicroelectronics NV and its subsidiaries ("ST") reserve the right to make changes, corrections, enhancements, modifications, and improvements to ST products and/or to this document at any time without notice. Purchasers should obtain the latest relevant information on ST products before placing orders. ST products are sold pursuant to ST's terms and conditions of sale in place at the time of order acknowledgement.

Purchasers are solely responsible for the choice, selection, and use of ST products and ST assumes no liability for application assistance or the design of Purchasers' products.

No license, express or implied, to any intellectual property right is granted by ST herein.

Resale of ST products with provisions different from the information set forth herein shall void any warranty granted by ST for such product.

ST and the ST logo are trademarks of ST. All other product or service names are the property of their respective owners.

Information in this document supersedes and replaces information previously supplied in any prior versions of this document.

© 2014 STMicroelectronics – All rights reserved





Компания «ЭлектроПласт» предлагает заключение долгосрочных отношений при поставках импортных электронных компонентов на взаимовыгодных условиях!

Наши преимущества:

- Оперативные поставки широкого спектра электронных компонентов отечественного и импортного производства напрямую от производителей и с крупнейших мировых складов;
- Поставка более 17-ти миллионов наименований электронных компонентов;
- Поставка сложных, дефицитных, либо снятых с производства позиций;
- Оперативные сроки поставки под заказ (от 5 рабочих дней);
- Экспресс доставка в любую точку России;
- Техническая поддержка проекта, помощь в подборе аналогов, поставка прототипов;
- Система менеджмента качества сертифицирована по Международному стандарту ISO 9001;
- Лицензия ФСБ на осуществление работ с использованием сведений, составляющих государственную тайну;
- Поставка специализированных компонентов (Xilinx, Altera, Analog Devices, Intersil, Interpoint, Microsemi, Aeroflex, Peregrine, Syfer, Eurofarad, Texas Instrument, Miteq, Cobham, E2V, MA-COM, Hittite, Mini-Circuits, General Dynamics и др.);

Помимо этого, одним из направлений компании «ЭлектроПласт» является направление «Источники питания». Мы предлагаем Вам помощь Конструкторского отдела:

- Подбор оптимального решения, техническое обоснование при выборе компонента;
- Подбор аналогов;
- Консультации по применению компонента;
- Поставка образцов и прототипов;
- Техническая поддержка проекта;
- Защита от снятия компонента с производства.



Как с нами связаться

Телефон: 8 (812) 309 58 32 (многоканальный)

Факс: 8 (812) 320-02-42

Электронная почта: org@eplast1.ru

Адрес: 198099, г. Санкт-Петербург, ул. Калинина, дом 2, корпус 4, литера А.