

THIS DRAWING IS A CONTROLLED DOCUMENT
PART NO. 6368011

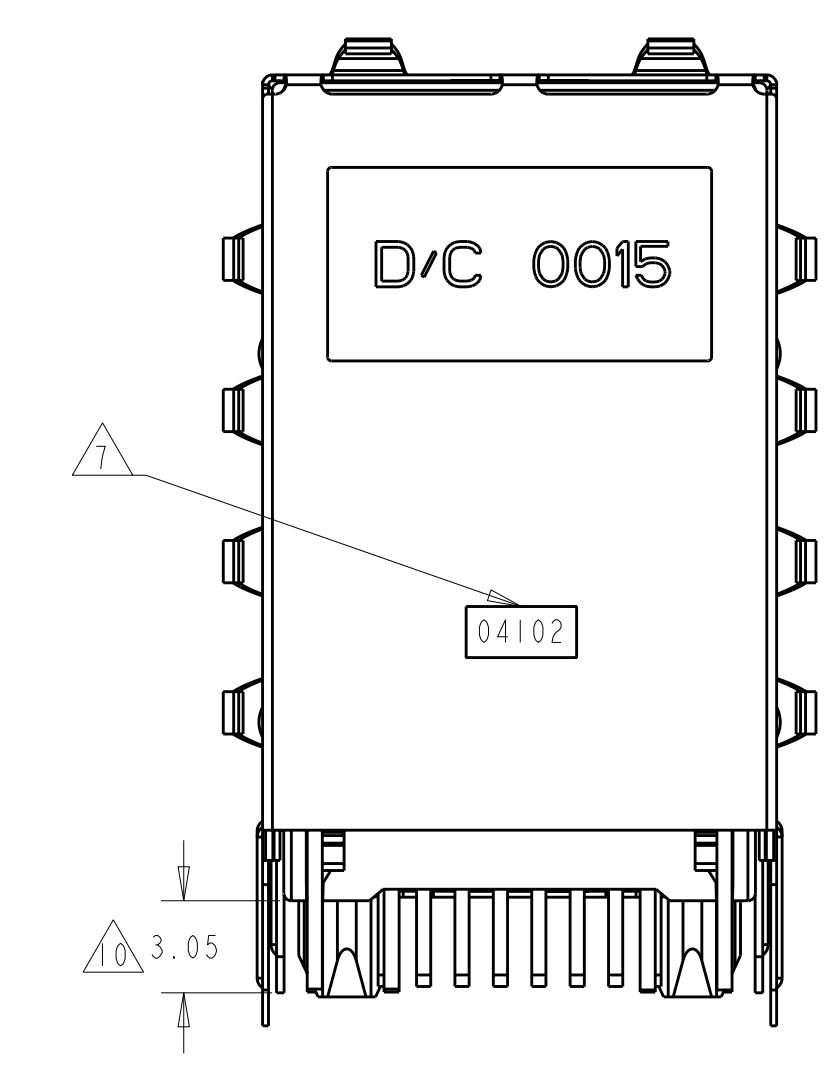

1. MATERIAL: **HOUSING** - PBT POLYESTER, BLACK, UL 94V-0.
TERMINALS - 0.33 THICK PHOSPHOR BRONZE PLATED WITH 1.27um MINIMUM THICK HARD GOLD IN LOCALIZED MATING INTERFACE AND 3.81um MINIMUM THICK MATTE TIN IN SOLDER AREA OVER 1.27um MINIMUM THICK NICKEL UNDERPLATE.
SHIELD - 0.196 THICK COPPER ALLOY PLATED WITH 1.27 um [0.00050] MINIMUM NICKEL AND 2.03 um [0.00080] MINIMUM HOT TIN DIP ON PCB GROUND TABS..
LIGHT EMITTING DIODE (LED) - DIFUSED EPOXY LENS, 0.51 X 0.51 CARBON STEEL WIREFRAME LEADS PREPLATED WITH 8.89 um THICK Sn/Cu OVER 2.03 um THICK Ag OVER 1.02 THICK Cu OVER 3.56 um THICK Ni OVER 1.02 um Cu UNDERPLATE

2. JACK CAVITY CONFORMS TO FCC RULES AND REGULATIONS, PART 68 SUBPART F.
3. SUGGESTED OPERATING CURRENT FOR THE LED IS 20mA. GREEN/ORANGE BI-COLOR LEDS ON 6368011-4 AND 1-6368011-0 WILL EMIT GREEN LIGHT ON FORWARD BIAS CURRENT AND ORANGE LIGHT ON REVERSE BIAS CURRENT. GREEN/RED BI-COLOR LEDS ON 6368011-9 AND 1-6368011-0 WILL EMIT GREEN LIGHT ON FORWARD BIAS CURRENT AND RED LIGHT ON REVERSE BIAS CURRENT. GREEN/YEL BI-COLOR LEDS ON 1-6368011-1 WILL EMIT GREEN LIGHT ON FORWARD BIAS CURRENT AND YELLOW LIGHT ON REVERSE BIAS CURRENT.
4. THIS MODULAR JACK WITH INTEGRATED LED IS NOT IR REFLOW SOLDERING PROCESS COMPATIBLE.
5. USE NO. 30 DRILL BIT OR 3.25mm DRILL BIT WHEN PRODUCING THESE PCB HOLES.
6. HM-15 LUBE APPLIED TO THE GOLD PLATED AREA OF THE TERMINALS ON 6368011-8 ONLY.
7. DATE CODE LOCATED ON REAR OF PART APPROX AS SHOWN: FIRST 2 DIGITS ARE LAST 2 DIGITS OF YEAR, SECOND 2 DIGITS ARE MANUFACTURING WORK WEEK, LAST DIGIT IS DAY OF WEEK, WITH SUNDAY=1.
8. THE PART NUMBER IS PRELIMINARY.
9. OBSOLETE PARTS: OBSOLETE CIS STREAMLINING PER D.RENAUD/D.SINISI
10. GROUND PIN AND ALL SIGNAL PINs' LENGTH SHOULD BE 4.06 MM EXCEPT OUTER SHIELD THIS REQUEST IS ONLY FOR PART 1-6368011-4

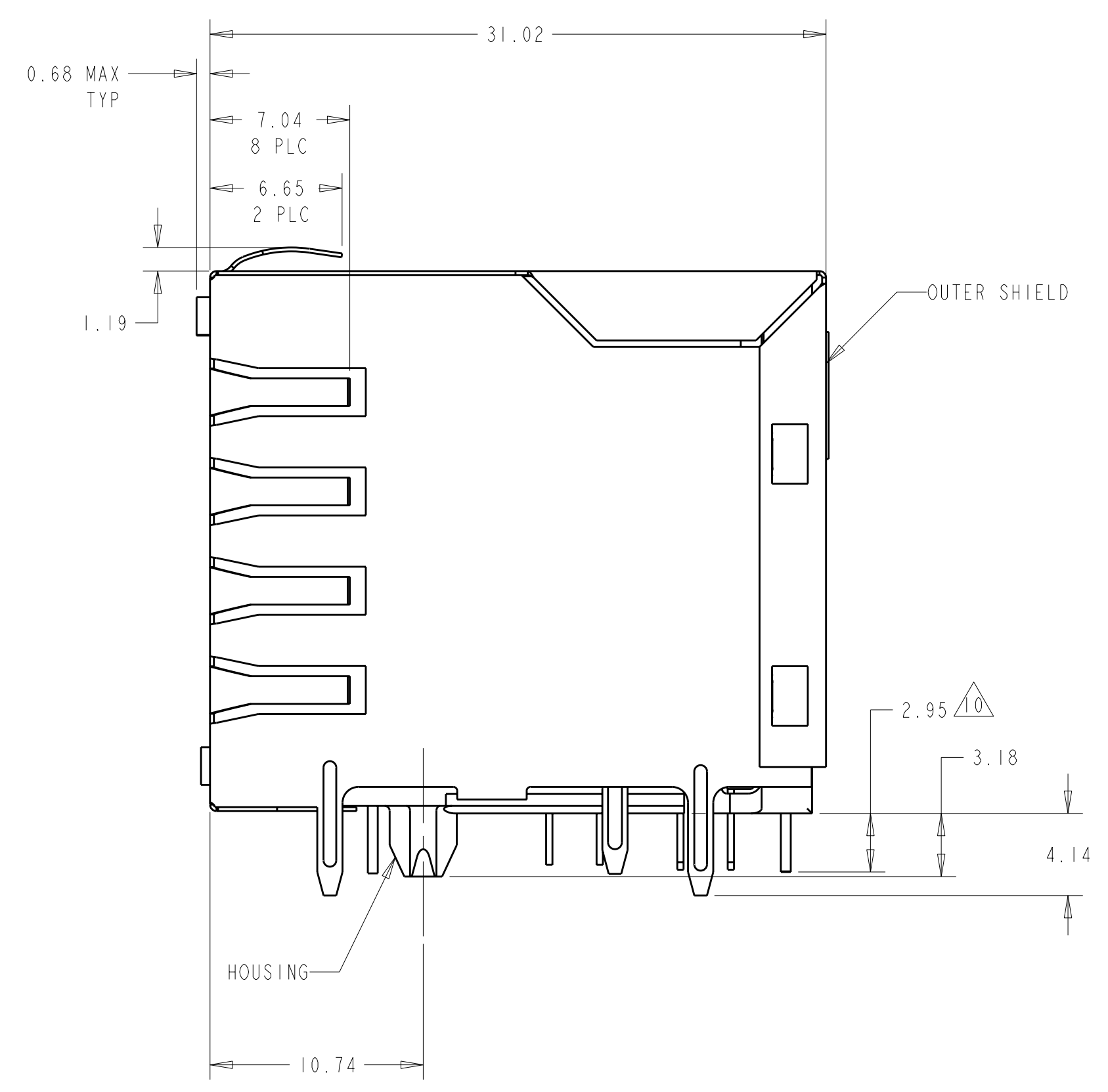
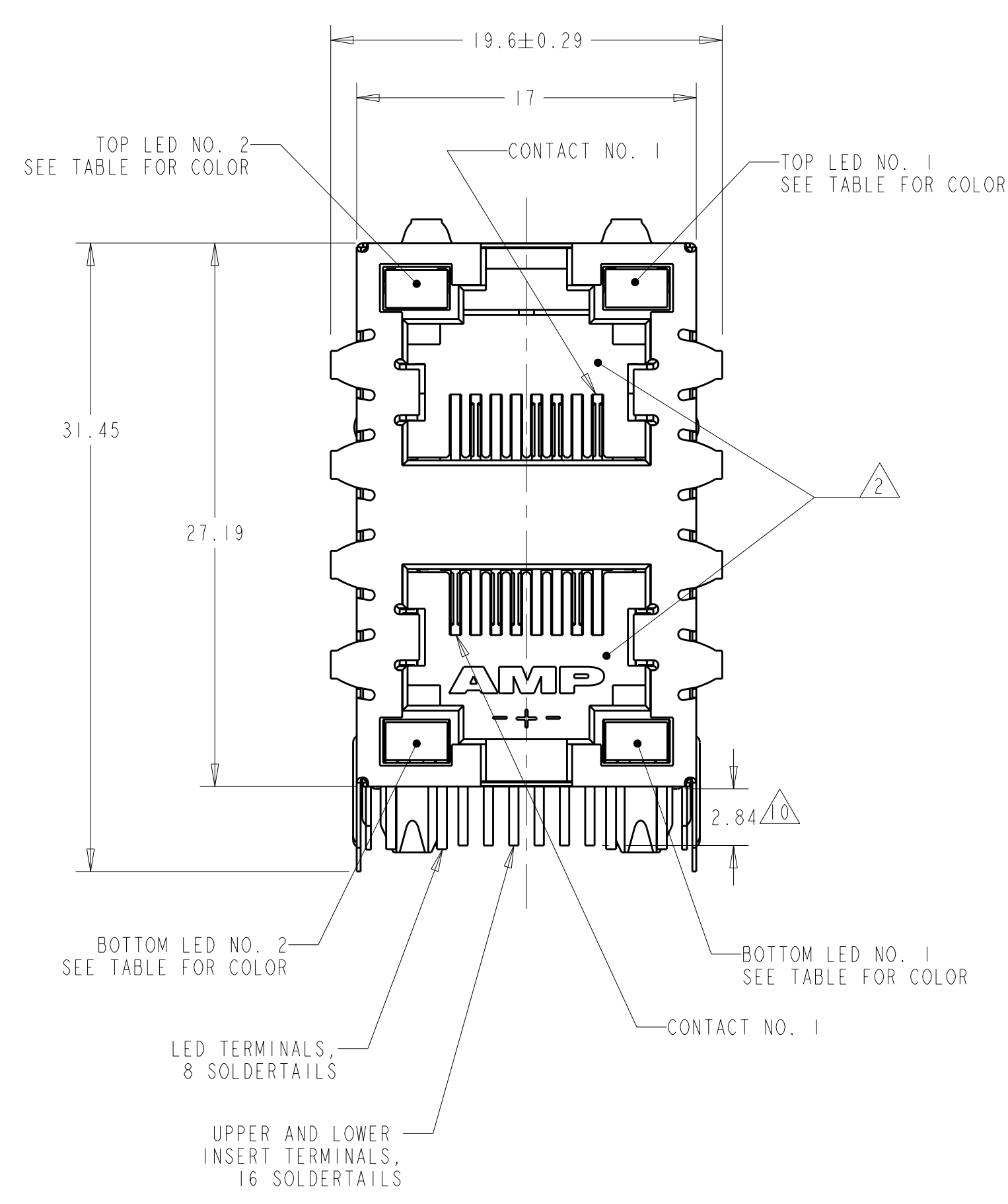
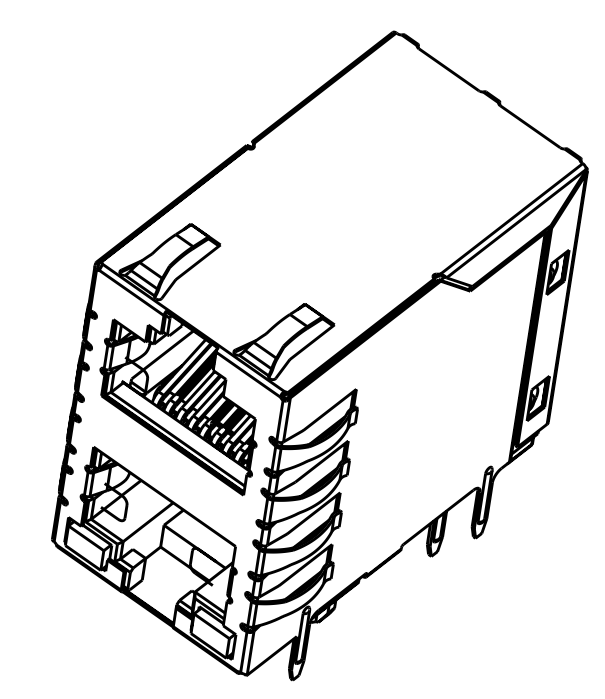
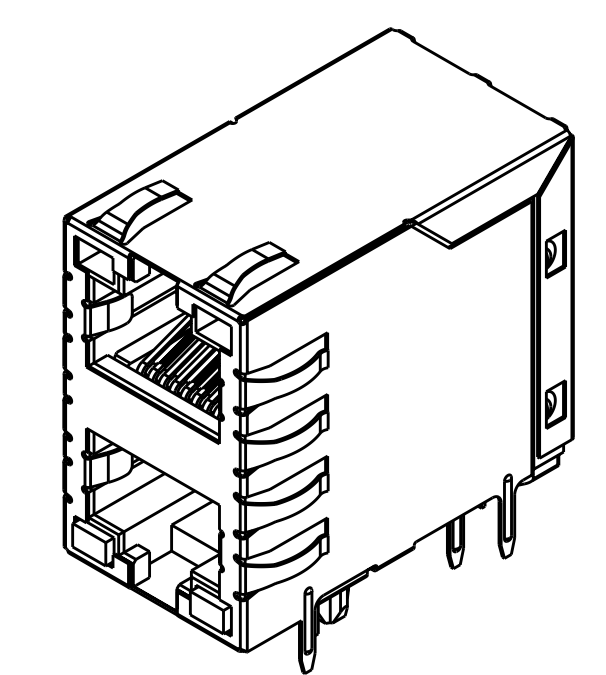
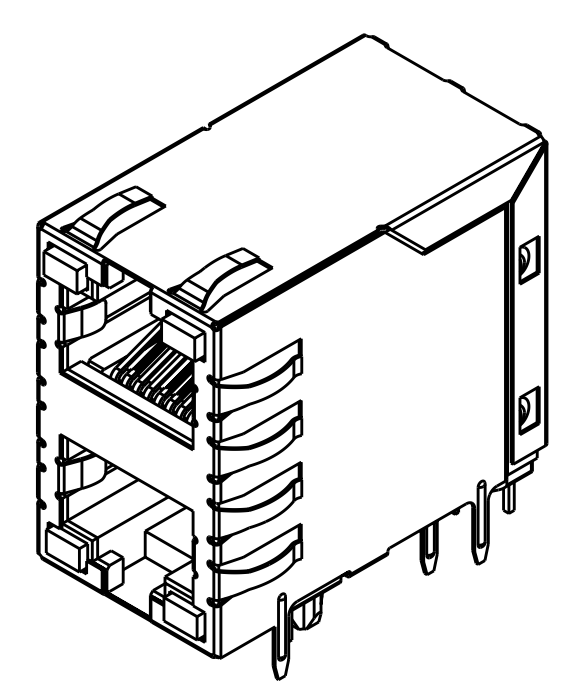
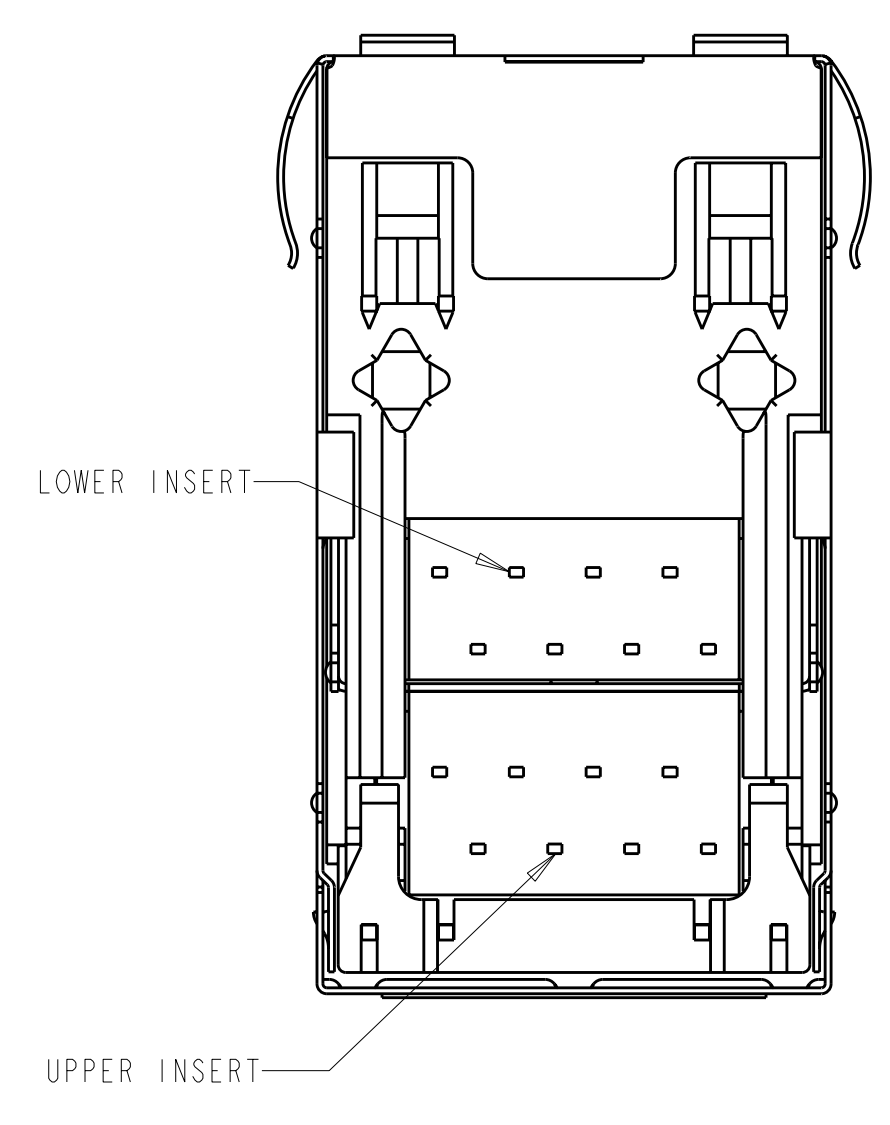

3.44 MAX	GREEN	GREEN	GREEN	GREEN	1-6368011-5
4.14	GREEN	YELLOW	GREEN	YELLOW	1-6368011-4
4.14	GREEN	YELLOW	N/A	N/A	1-6368011-3/8
4.14	GREEN/YELLOW	GREEN/YELLOW	GREEN/YELLOW	GREEN/YELLOW	1-6368011-0
4.14	GREEN/ORANGE	GREEN/ORANGE	GREEN/RED	GREEN/RED	1-6368011-1
4.14	GREEN/RED	GREEN/RED	GREEN/RED	GREEN/RED	6368011-9
4.14	YELLOW	GREEN	YELLOW	GREEN	6368011-8/6
4.14	GREEN	ORANGE	N/A	N/A	6368011-7
4.14	GREEN	GREEN	YELLOW	GREEN	6368011-6
4.14	YELLOW	GREEN	YELLOW	GREEN	6368011-5
4.14	GREEN/ORANGE	GREEN/ORANGE	GREEN/ORANGE	GREEN/ORANGE	6368011-4
4.14	GREEN	YELLOW	GREEN	YELLOW	6368011-3
4.14	YELLOW	GREEN	GREEN	YELLOW	6368011-2
4.14	GREEN	GREEN	GREEN	GREEN	6368011-1
DIM A	BOTTOM LED NO. 2	BOTTOM LED NO. 1	TOP LED NO. 2	TOP LED NO. 1	PART NUMBER

9 OBSOLETE

9 OBSOLETE

DWN Vic Slack/L.A.MAYER		13APR2005	MATERIAL SEE NOTE 1		HEAT TREAT -
CHK J.WESTMAN		13APR2005	TE Connectivity		
APVD S.FLICKINGER		13APR2005	NAME MODULAR JACK ASSEMBLY, STACKED, 2 X 1, 8 POSITION, SHIELDED,		
SCALE 1:1		SIZE A1	DRAWING NO. 6368011	SHEET 1 of 3	REV J

3308-B 13/11
P:ENGINEER DRAWING

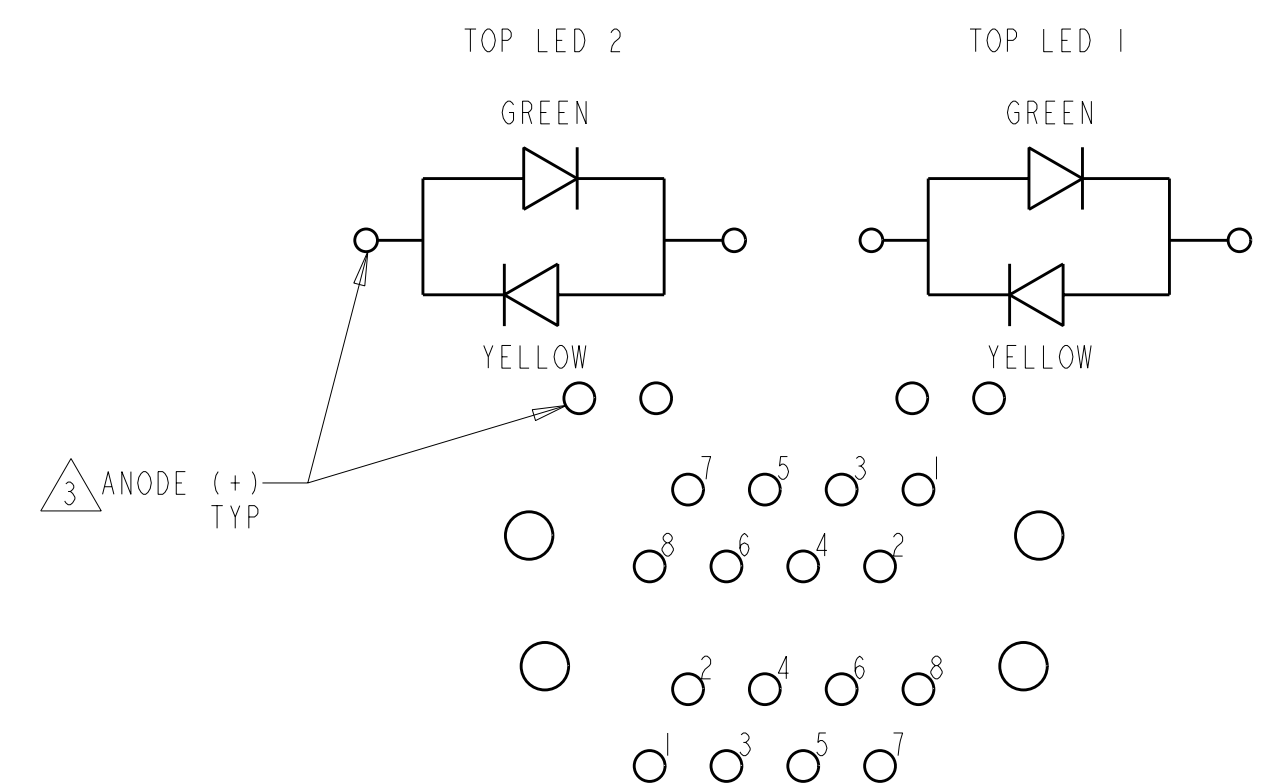

SCHEMATIC FOR 1-6368011-1
SCALE 4:1

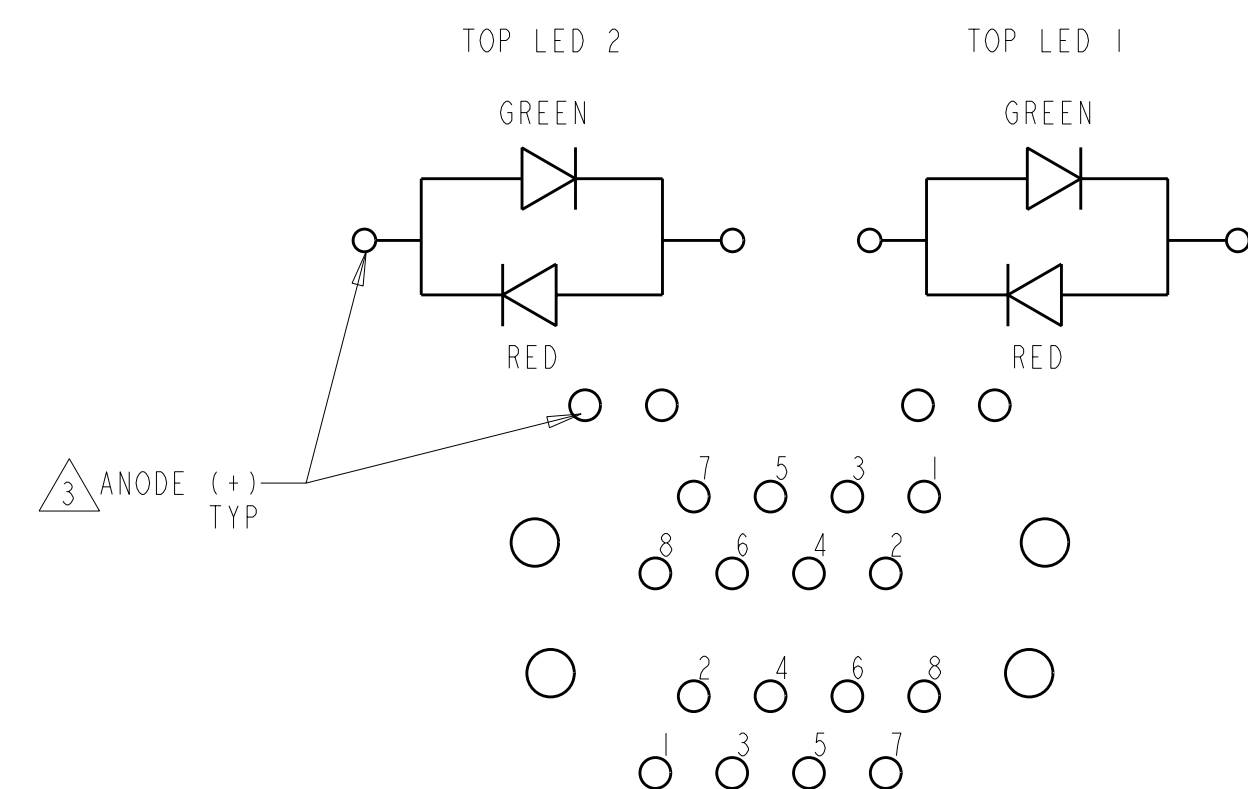

SCHEMATIC FOR 1-6368011-0
SCALE 4:1

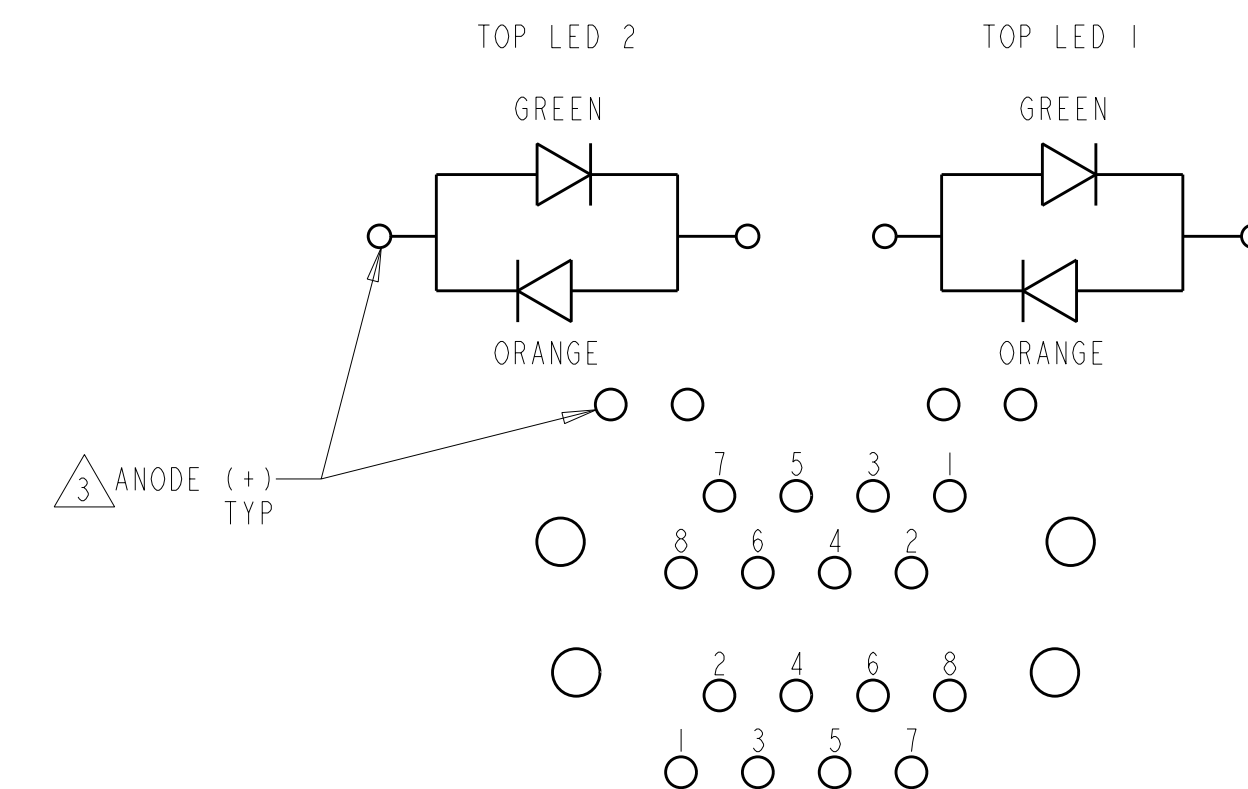

SCHEMATIC FOR 6368011-4
SCALE 4:1

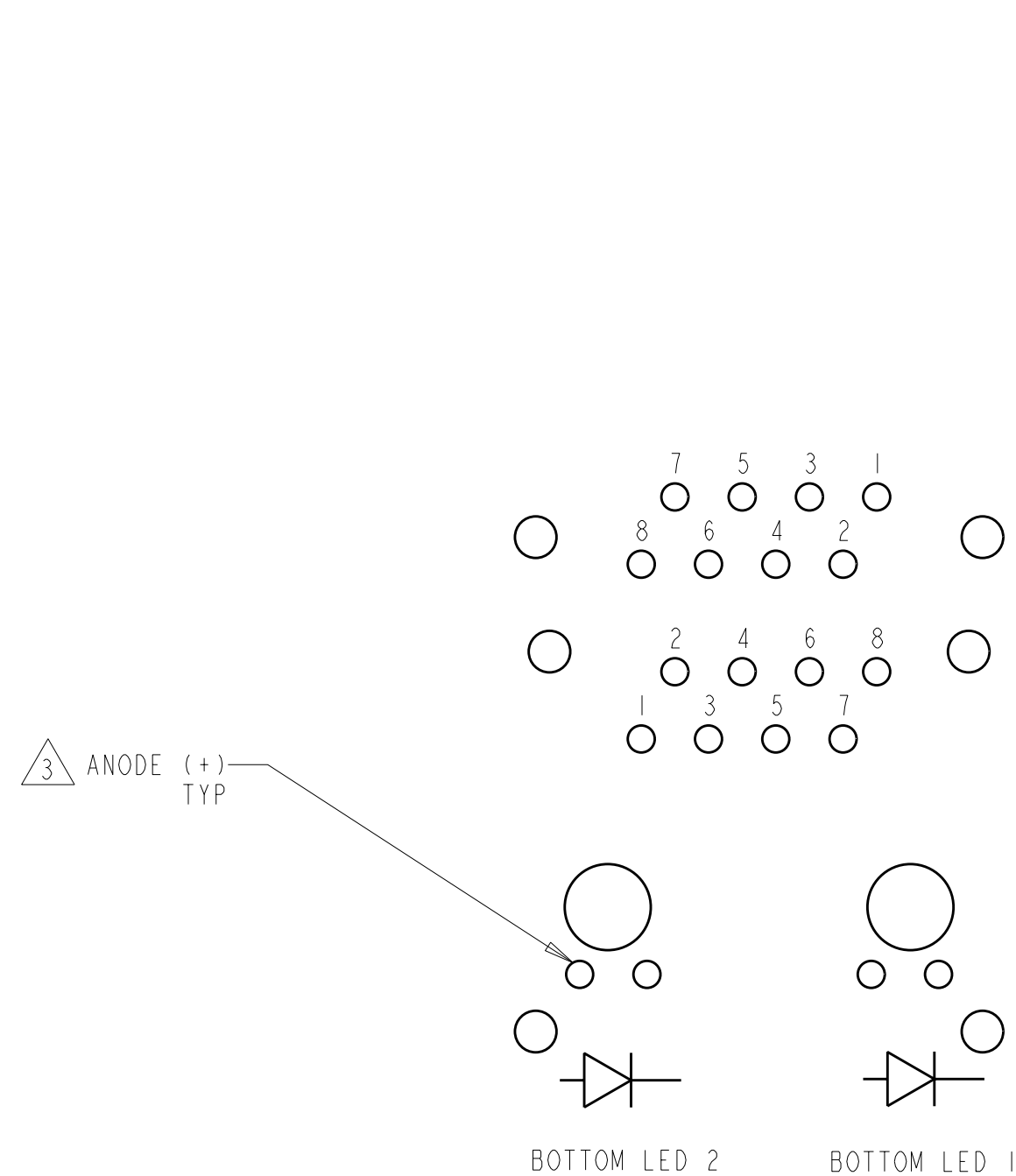

SCHEMATIC FOR 6368011-7, 1-6368011-3

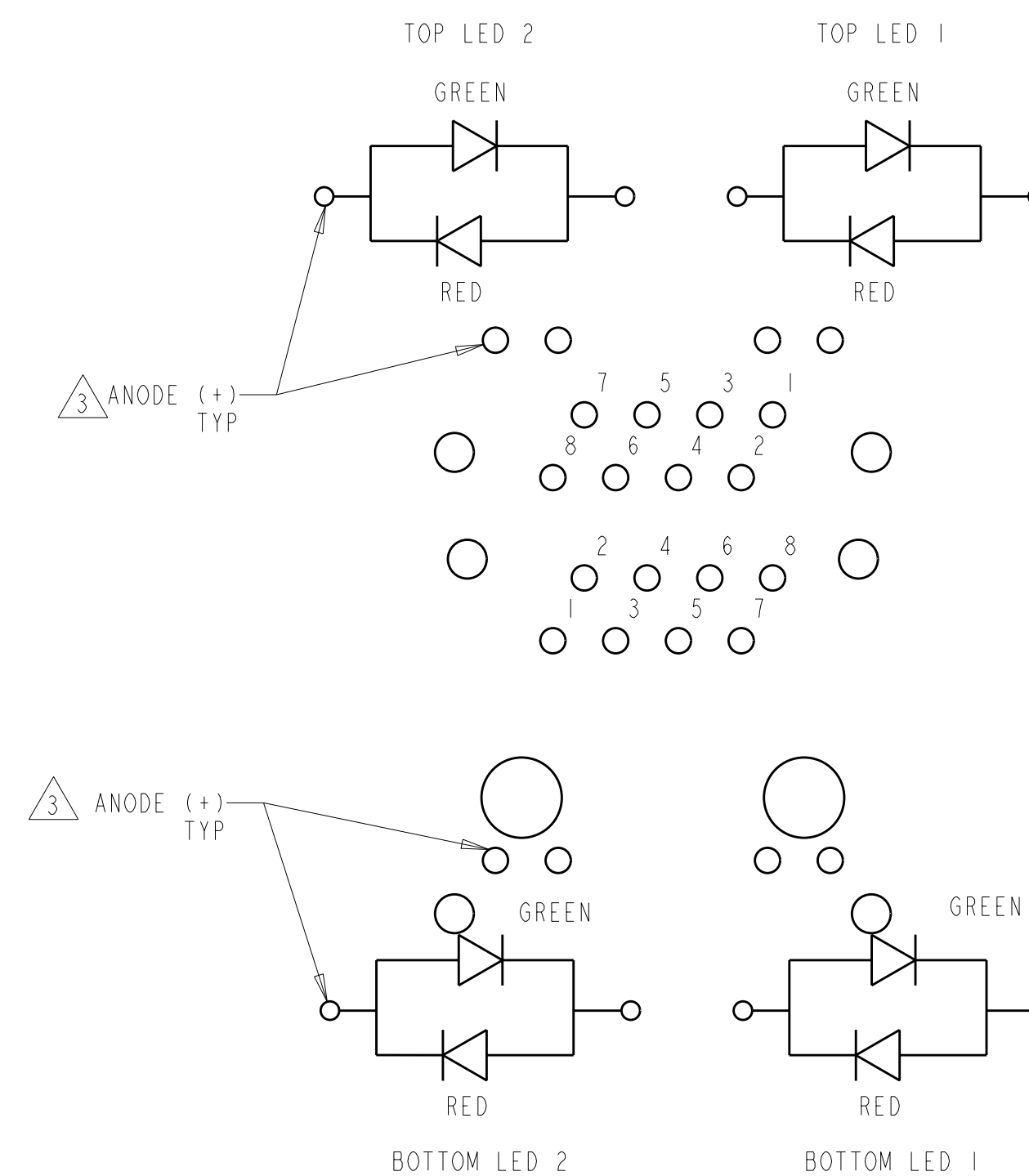

SCHEMATIC FOR 6368011-9
SCALE 4:1

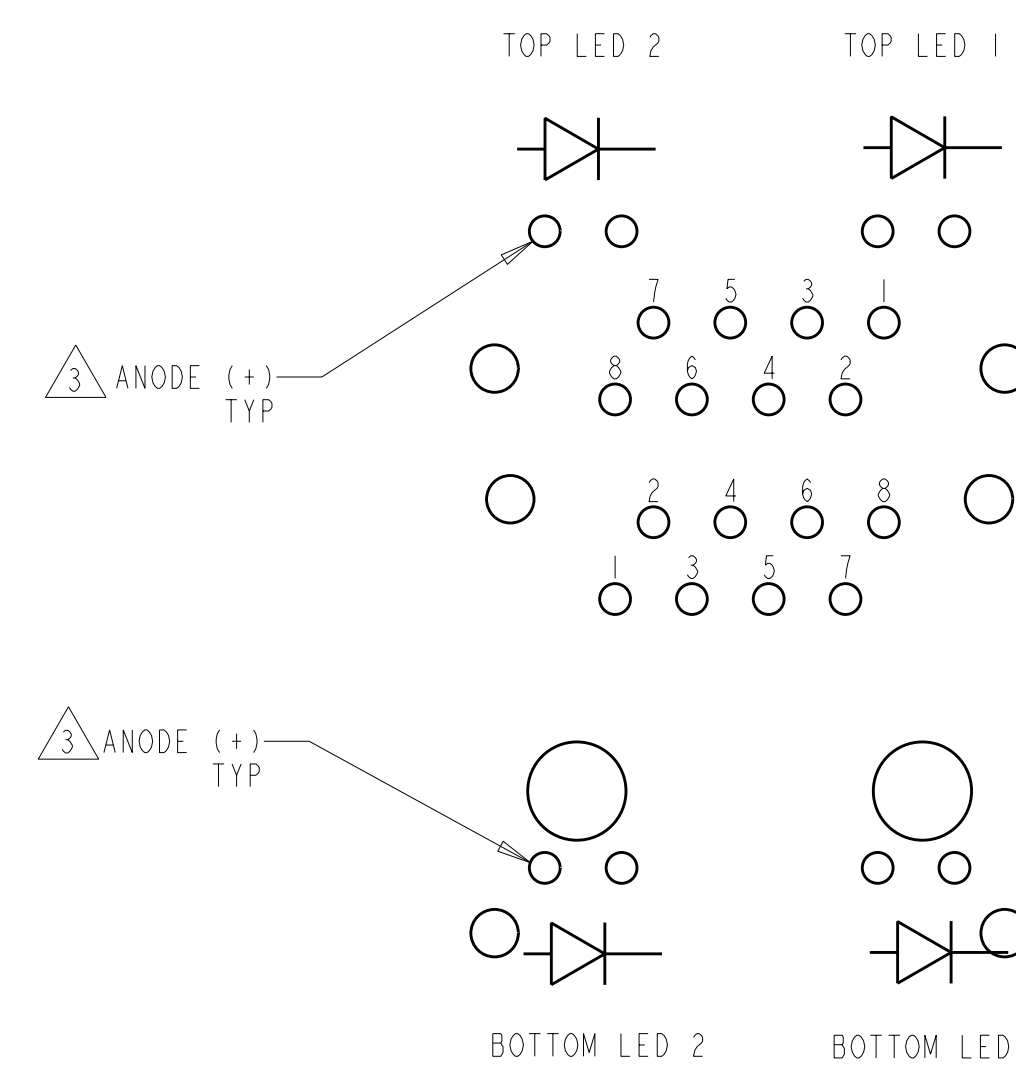

SCHEMATIC FOR 6368011-1, -2, -3, -5, -6, -8, 14
SCALE 4:1

LOC	AA
DIST	22

P	LTR	REVISION RECORD	DATE	DN	APVD
		SEE SHEET 1			

DIMENSIONS:		TOLERANCES UNLESS OTHERWISE SPECIFIED:	
mm		0 PLC	±
		1 PLC	±
		2 PLC	±0.25
		3 PLC	±0.25
		4 PLC	±
ANGLES:		SURFACE TEXTURE	
			✓

DNW	13APR2005	MATERIAL	SEE NOTE 1	HEAT TREAT	-
CHK	13APR2005				
APVD	13APR2005				
NAME		MODULAR JACK ASSEMBLY, STACKED, 2 X 1, 8 POSITION, SHIELDED,			
SCALE	1:1	DRAWING NO	6368011	SHEET	2 of 3
	A1			REV	J



DWG NO 6368011

THIS DRAWING IS A CONTROLLED DOCUMENT

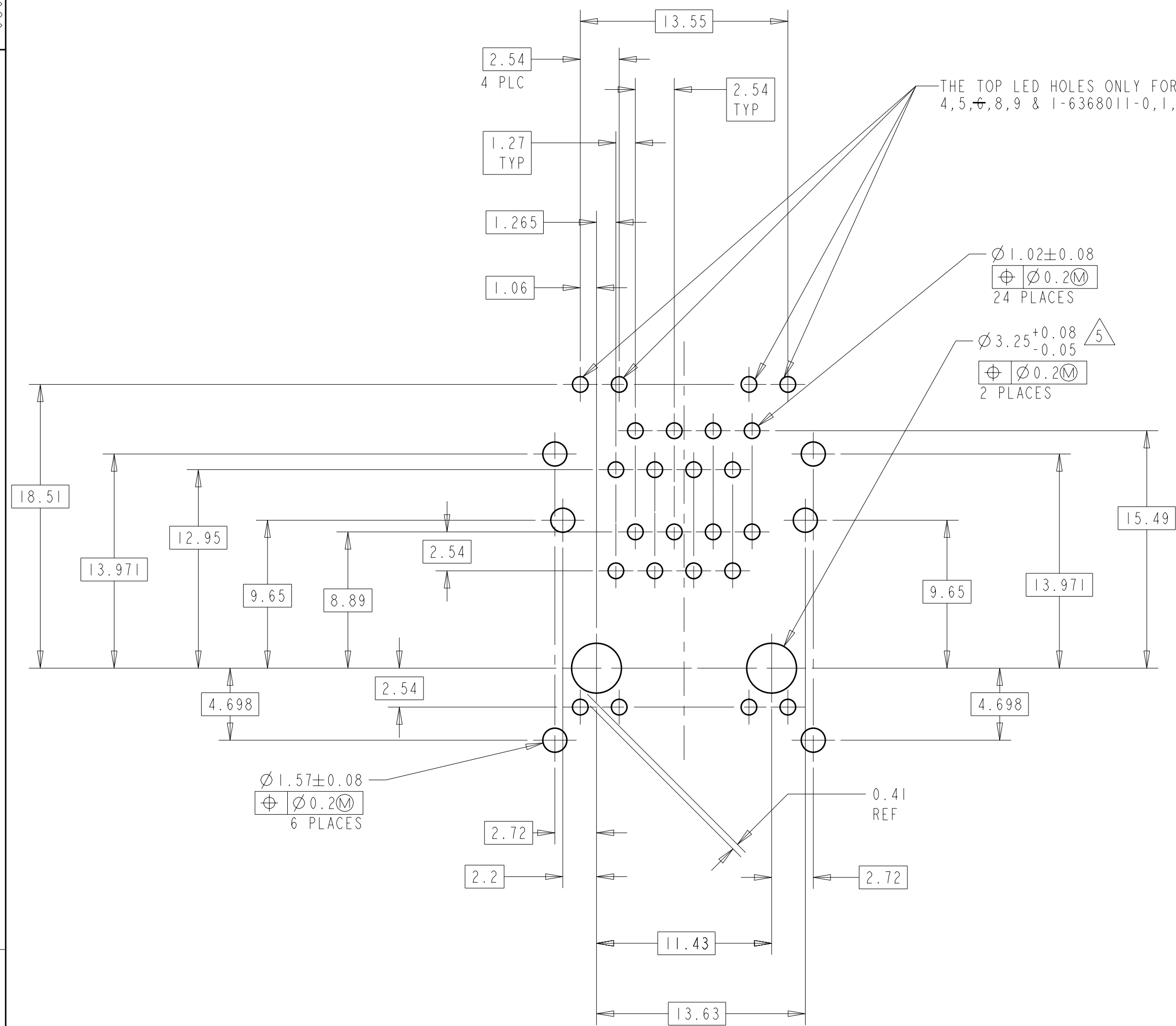

PC BOARD LAYOUT VIEWED FROM COMPONENT SIDE OF BOARD
SCALE 4:1

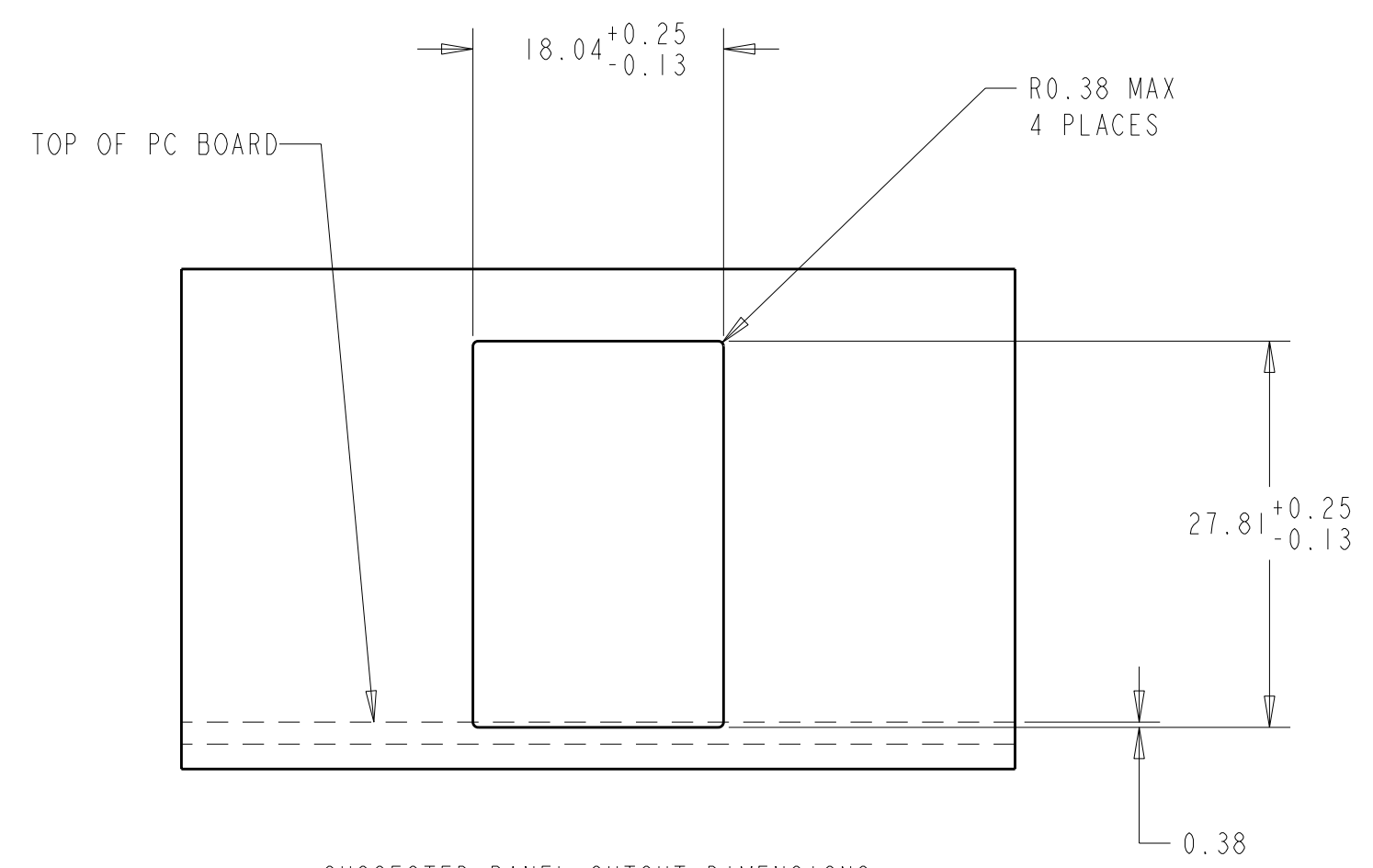

SUGGESTED PANEL CUTOUT DIMENSIONS
SCALE 2:1

THIS INFORMATION IS CONFIDENTIAL AND PROPRIETARY TO TEO ELECTRONICS CORPORATION. IT IS TO BE KEPT AS SUCH AND NOT TO BE DISCLOSED TO ANYONE, OTHER THAN THE PERSONNEL, WITHOUT AUTHORIZATION FROM TEO ELECTRONICS CORPORATION.

LOC	AA
DIST	22

P	LTR	REVISION RECORD	DATE	DWN	APVD
-	-	SEE SHEET 1	-	-	-

DIMENSIONS:		TOLERANCES UNLESS OTHERWISE SPECIFIED:	
mm		0 PLC	±
		1 PLC	±
		2 PLC	±0.25
		3 PLC	±0.25
		4 PLC	±
ANGLES:		SURFACE TEXTURE	
		√	

DWN	13APR2005	MATERIAL	SEE NOTE 1	HEAT TREAT	-
CHK	Vic Slack/L.A.MAYER				
APVD	13APR2005				
	J.WESTMAN				
	S.FLICKINGER				
NAME MODULAR JACK ASSEMBLY, STACKED, 2 X 1, 8 POSITION, SHIELDED,					
SCALE	1:1	SIZE	A1	DRAWING NO	6368011
SHEET	3	OF	3	REV	J





Компания «ЭлектроПласт» предлагает заключение долгосрочных отношений при поставках импортных электронных компонентов на взаимовыгодных условиях!

Наши преимущества:

- Оперативные поставки широкого спектра электронных компонентов отечественного и импортного производства напрямую от производителей и с крупнейших мировых складов;
- Поставка более 17-ти миллионов наименований электронных компонентов;
- Поставка сложных, дефицитных, либо снятых с производства позиций;
- Оперативные сроки поставки под заказ (от 5 рабочих дней);
- Экспресс доставка в любую точку России;
- Техническая поддержка проекта, помощь в подборе аналогов, поставка прототипов;
- Система менеджмента качества сертифицирована по Международному стандарту ISO 9001;
- Лицензия ФСБ на осуществление работ с использованием сведений, составляющих государственную тайну;
- Поставка специализированных компонентов (Xilinx, Altera, Analog Devices, Intersil, Interpoint, Microsemi, Aeroflex, Peregrine, Syfer, Eurofarad, Texas Instrument, Miteq, Cobham, E2V, MA-COM, Hittite, Mini-Circuits, General Dynamics и др.);

Помимо этого, одним из направлений компании «ЭлектроПласт» является направление «Источники питания». Мы предлагаем Вам помощь Конструкторского отдела:

- Подбор оптимального решения, техническое обоснование при выборе компонента;
- Подбор аналогов;
- Консультации по применению компонента;
- Поставка образцов и прототипов;
- Техническая поддержка проекта;
- Защита от снятия компонента с производства.



Как с нами связаться

Телефон: 8 (812) 309 58 32 (многоканальный)

Факс: 8 (812) 320-02-42

Электронная почта: org@eplast1.ru

Адрес: 198099, г. Санкт-Петербург, ул. Калинина, дом 2, корпус 4, литера А.