

# M0216SD-162SDAR2-1

## Vacuum Fluorescent Display Module

RoHS Compliant

**Newhaven Display International, Inc.**

2511 Technology Drive, Suite 101

Elgin IL, 60124

Ph: 847-844-8795

Fax: 847-844-8796

[www.newhavendisplay.com](http://www.newhavendisplay.com)

[nhtech@newhavendisplay.com](mailto:nhtech@newhavendisplay.com)

[nhsales@newhavendisplay.com](mailto:nhsales@newhavendisplay.com)

## 1.0 SCOPE

This specification applies to VFD module (Model NO: M0216SD-162SDAR2-1) .

## 2.0 FEATURES

- \*Since a DC/DC converter is used, only +5Vdc power source is required to operate the module.
- \*5x8 dot matrix display, DC-DC/AC converter, and controller/driver circuitry.
- \*High quality display and luminance.
- \*ASCII and Japanese characters (CG-ROM font).
- \*The module can be configured for a Motorola M68-type parallel interface, an Intel I80-type parallel interface, or synchronous serial ainterface.

STANDARD NAME	 <b>NEWHAVEN DISPLAY</b> INTERNATIONAL	DOCUMENT NO.	REV. NO.	PAGE
		M0216SD-162SDAR2-1	03	2/24

### 3.0 SPECIFICATIONS

#### 3.1 GENERAL SPECIFICATIONS

ITEM		VALUE
Number of characters (char x line)		16 x 2
Character configuration		5 x 8 dot matrix
Character height (mm)		5.34
Character width (mm)		2.10
Character pitch (mm)		3.30
Line pitch (mm)		6.16
Dot size (mm)	width	0.34
	height	0.58
Dot pitch (mm)	width	0.44
	height	0.68
Peak wavelength of illumination		Green (505 nm) x = 0.235, y = 0.405
Luminance (cd/m <sup>2</sup> / fL)	min.	350 / 102
	typ.	500 / 146

STANDARD  
NAME



DOCUMENT NO.

REV. NO.

PAGE

M0216SD-162SDAR2-1

03

3/24

### 3.2 MECHANICAL DRAWINGS

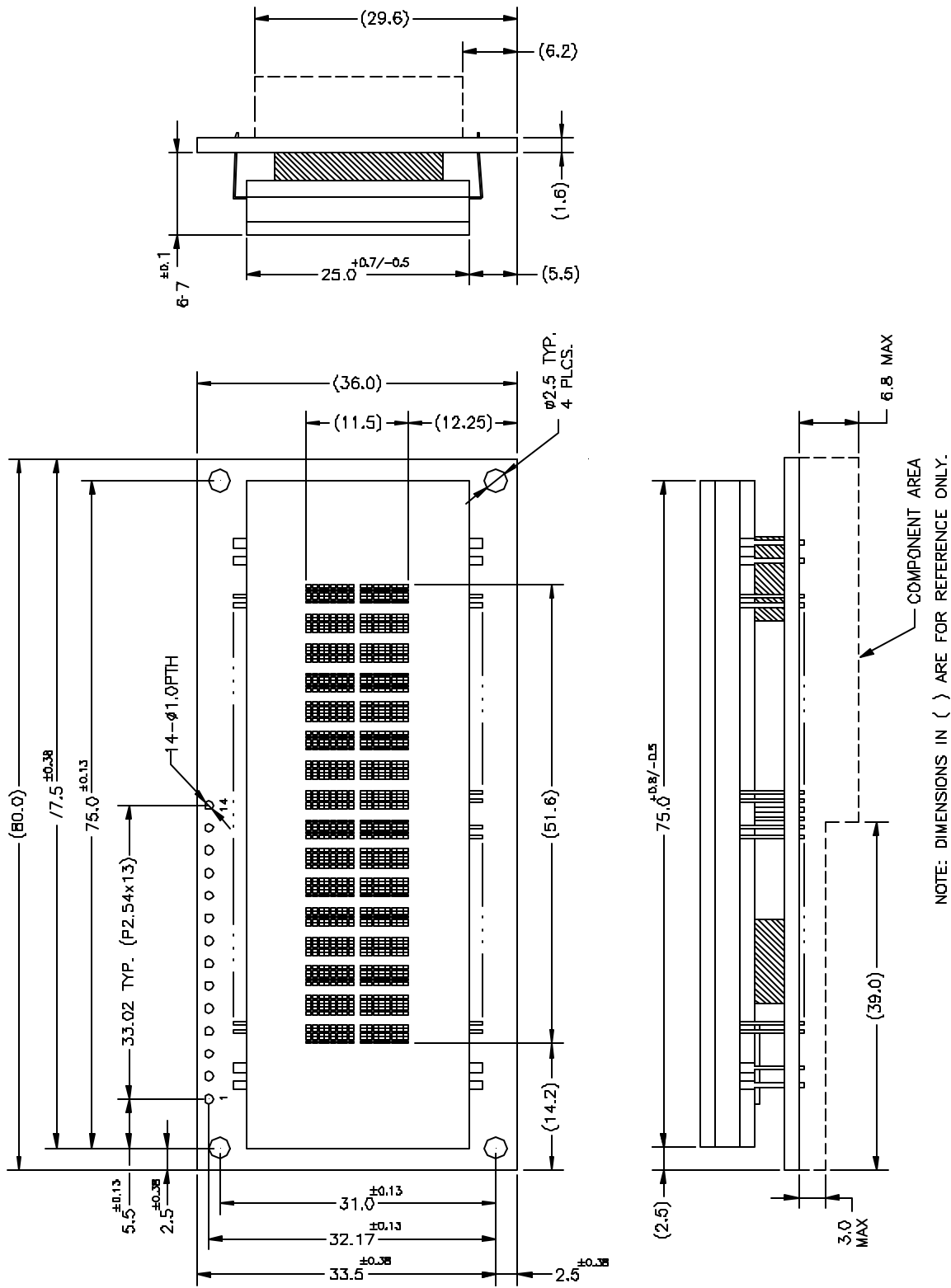

NOTE: DIMENSIONS IN ( ) ARE FOR REFERENCE ONLY.

STANDARD NAME	 <b>NEWHAVEN DISPLAY</b> INTERNATIONAL	DOCUMENT NO.	REV. NO.	PAGE
		M0216SD-162SDAR2-1	03	4/24

### 3.3 SYSTEM BLOCK DIAGRAM

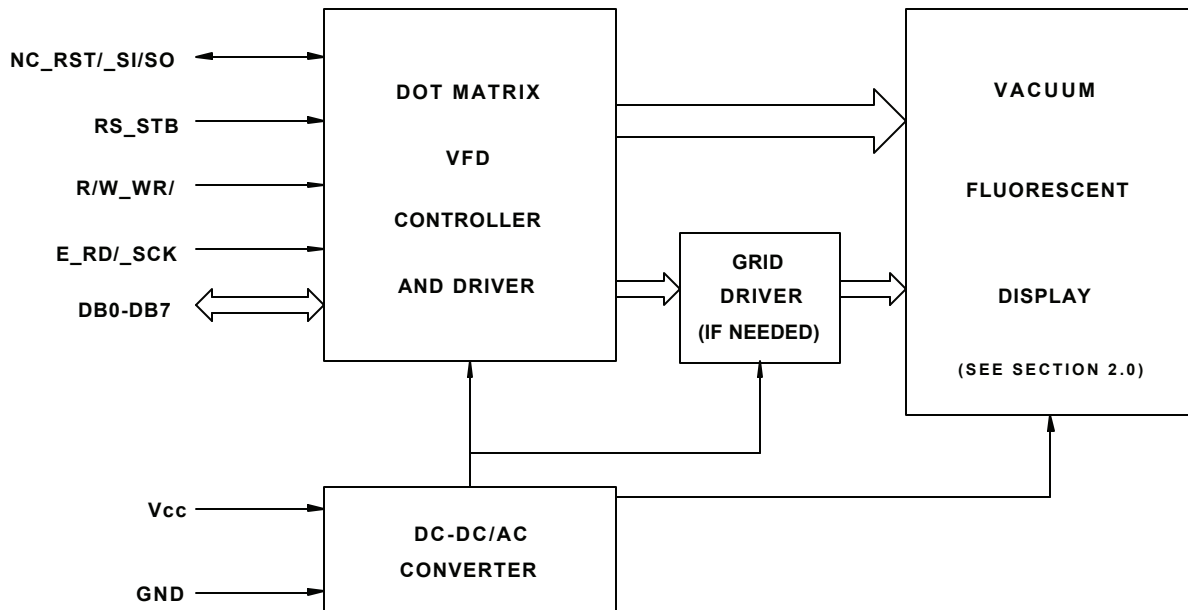

### 3.4 ENVIRONMENTAL SPECIFICATIONS

Item	Symbol	Min.	Max.	Unit	Comment
Operating temperature	Topr	-40	+85	°C	
Storage temperature	Tstg	-50	+95	°C	
Operating humidity	Hopr	20	85	%RH	Without condensation
Storage humidity	Hstg	20	90	%RH	Without condensation
Vibration	--	--	4	G	Total amplitude: 1.5mm Freq: 10 - 55 Hz sine wave Sweep time: 1 min./cycle Duration: 2 hrs./axis (X,Y,Z)
Shock	--	--	40	G	Duration: 11ms Waveform: half sine wave 3 times/axis (X,Y,Z,-X,-Y,-Z)

### 3.5 ABSOLUTE MAXIMUM SPECIFICATIONS

Item	Symbol	Min.	Max.	Unit
Supply voltage	V <sub>CC</sub>	-0.3	6.5	V
Input signal voltage	V <sub>IN</sub>	-0.3	V <sub>CC</sub> +0.3	V

STANDARD  
NAME



DOCUMENT NO.

REV. NO.

PAGE

M0216SD-162SDAR2-1

03

5/24

### 3.6 DC ELECTRICAL SPECIFICATIONS

Item	Symbol	Min.	Typ.	Max.	Unit
Supply voltage	$V_{CC}$	4.5	5.0	5.5	V
Supply current	$I_{CC}$	-	170	220	mA
High-level input voltage (see Note) (E,RD/,SCK,RST/)	$V_{IH1}$	$0.8*V_{CC}$	-	$V_{CC}$	V
Low-level input voltage (see Note) (E,RD/,SCK,RST/)	$V_{IL1}$	0.0	-	$0.2*V_{CC}$	V
High-level input voltage (see Note) (all inputs except E,RD/,SCK,RST/)	$V_{IH2}$	$0.7*V_{CC}$	-	$V_{CC}$	V
Low-level input voltage (see Note) (all inputs except E,RD/,SCK,RST/)	$V_{IL2}$	0.0	-	$0.3*V_{CC}$	V
High-level output voltage ( $I_{OH} = -0.1mA$ )	$V_{OH}$	$V_{CC}-0.5$	-	-	V
Low-level output voltage ( $I_{OL} = 0.1mA$ )	$V_{OL}$	-	-	0.5	V
Input current (see Note)	$I_I$	-500	-	1.0	uA

Note: A 10K ohm pull-up resistor is provided on each input for TTL compatibility.

### 3.7 AC ELECTRICAL SPECIFICATIONS

#### 3.7.1 RESET TIMING

(See Figures 1 and 2)

Item	Symbol	Min.	Max.	Unit
$V_{CC}$ rise time	$t_{RVCC}$	-	10	ms
$V_{CC}$ off time	$t_{OFF}$	1	-	ms
Delay time after power-up reset	$t_{RSTD}$	100	-	us
Delay time after external reset	$t_{ERSTD}$	100	-	us
RST/ pulse width low	$t_{RSTL}$	500	-	ns
Input signal fall time	$t_f$	-	15	ns
Input signal rise time	$t_r$	-	15	ns

Note: All timing is specified using 20% and 80% of  $V_{CC}$  as the reference points.

STANDARD NAME		DOCUMENT NO.	REV. NO.	PAGE
		M0216SD-162SDAR2-1	03	6/24

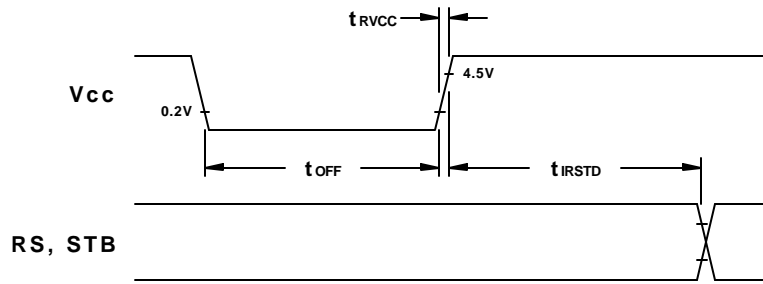

**Figure 1.** Power-up Internal Reset Timing

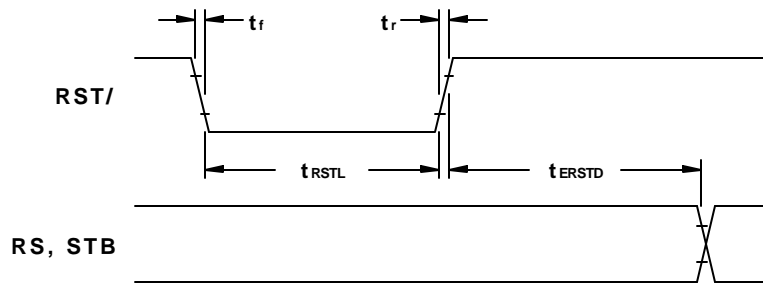

**Figure 2.** External Reset Timing

### 3.7.2 MOTOROLA M68-TYPE PARALLEL INTERFACE TIMING

(See Figures 3 and 4)

Item	Symbol	Min.	Max.	Unit
RS, R/W setup time	$t_{AS}$	20	-	ns
RS, R/W hold time	$t_{AH}$	10	-	ns
Input signal rise time	$t_r$	-	15	ns
Input signal fall time	$t_f$	-	15	ns
E pulse width high	$PW_{EH}$	230	-	ns
E pulse width low	$PW_{EL}$	230	-	ns
Write data setup time	$t_{DS}$	80	-	ns
Write data hold time	$t_{DH}$	10	-	ns
E cycle time	$t_{CYCE}$	500	-	ns
Read data delay time	$t_{DD}$	-	160	ns
Read data hold time	$t_{DHR}$	5	-	ns

Note: All timing is specified using 20% and 80% of  $V_{CC}$  as the reference points.

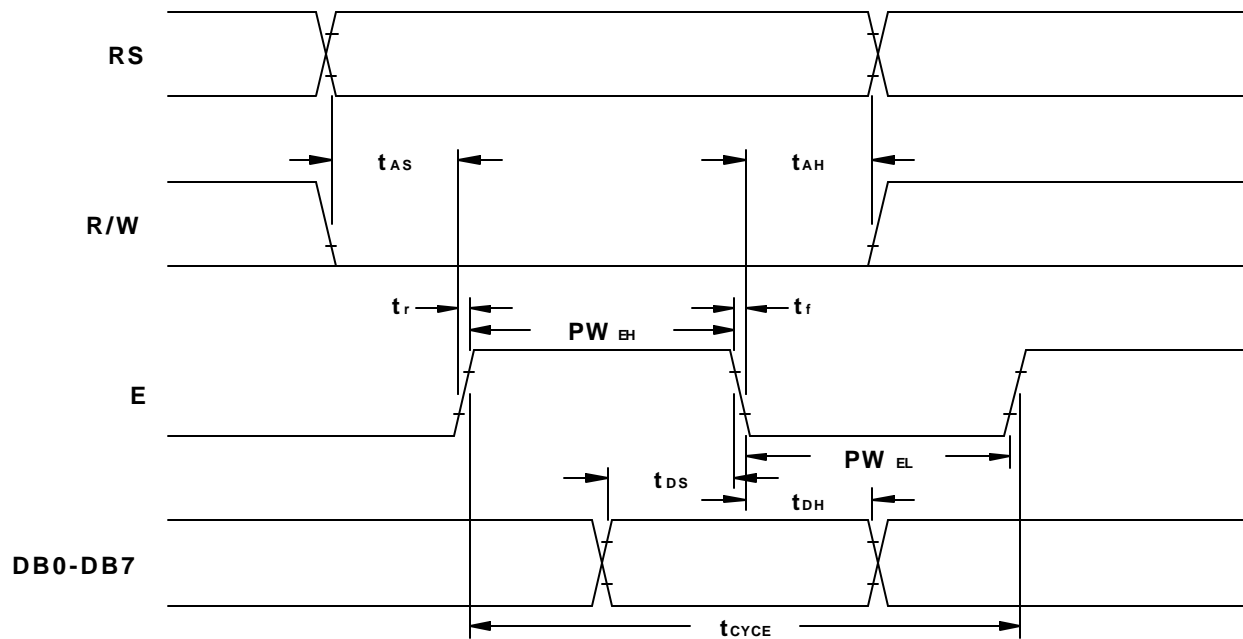

**Figure 3.** Motorola M68-Type Parallel Interface Write Cycle Timing

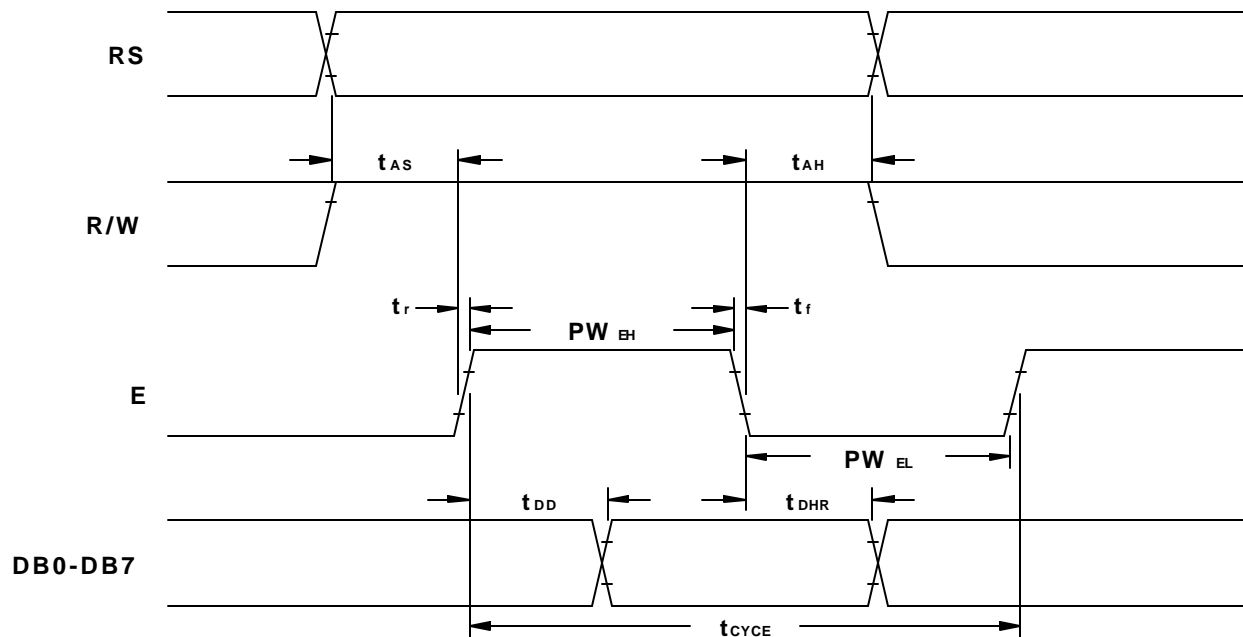

**Figure 4.** Motorola M68-Type Parallel Interface Read Cycle Timing



### 3.7.3 INTEL I80-TYPE PARALLEL INTERFACE TIMING

(See Figures 5 and 6)

Item	Symbol	Min.	Max.	Unit
RS setup time	$t_{RSS}$	10	-	ns
RS hold time	$t_{RSH}$	10	-	ns
Input signal fall time	$t_f$	-	15	ns
Input signal rise time	$t_r$	-	15	ns
WR/ pulse width low	$t_{WRL}$	30	-	ns
WR/ pulse width high	$t_{WRH}$	100	-	ns
Write data setup time	$t_{DSi}$	30	-	ns
Write data hold time	$t_{DHi}$	10	-	ns
WR/ cycle time	$t_{CYCWR}$	166	-	ns
RD/ cycle time	$t_{CYCRD}$	166	-	ns
RD/ pulse width low	$t_{RDl}$	70	-	ns
RD/ pulse width high	$t_{RDH}$	70	-	ns
Read data delay time	$t_{DDi}$	-	70	ns
Read data hold time	$t_{DHRi}$	5	50	ns

Note: All timing is specified using 20% and 80% of  $V_{CC}$  as the reference points.

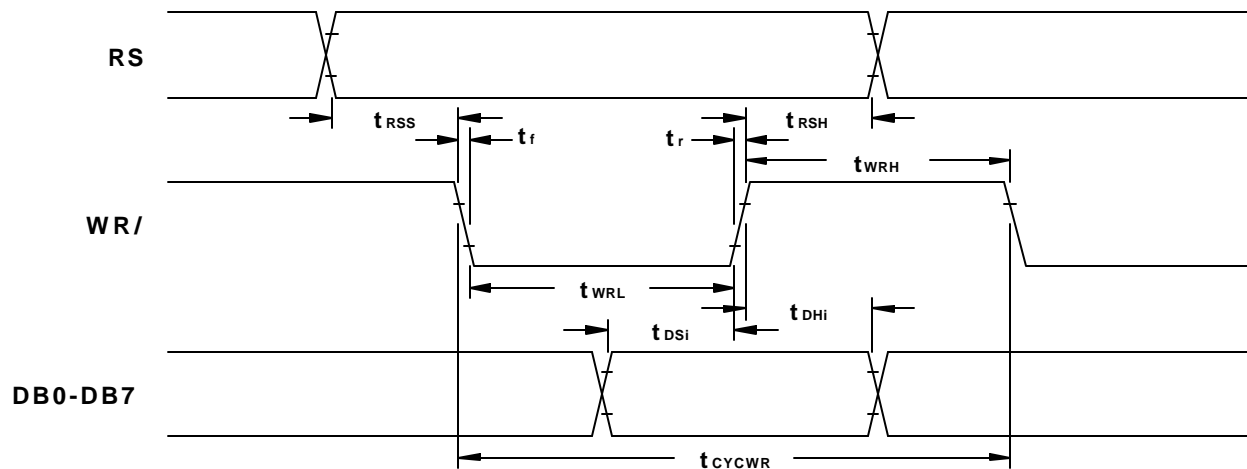
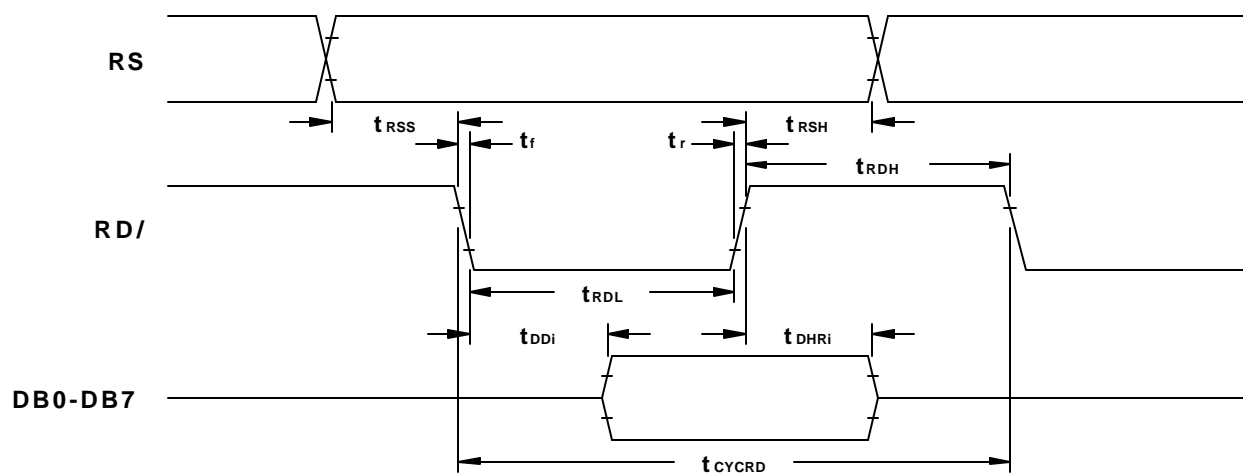

Figure 5. Intel I80-Type Parallel Interface Write Cycle Timing



**Figure 6. Intel I80-Type Parallel Interface Read Cycle Timing**

### 3.7.4 SYNCHRONOUS SERIAL INTERFACE TIMING

(See Figures 7, 8 and 12)

Item	Symbol	Min.	Max.	Unit
STB setup time	$t_{STBS}$	100	-	ns
STB hold time	$t_{STBH}$	500	-	ns
Input signal fall time	$t_f$	-	15	ns
Input signal rise time	$t_r$	-	15	ns
STB pulse width high	$t_{WSTB}$	500	-	ns
SCK pulse width high	$t_{SCKH}$	200	-	ns
SCK pulse width low	$t_{SCKL}$	200	-	ns
SI data setup time	$t_{DSS}$	100	-	ns
SI data hold time	$t_{DHS}$	100	-	ns
SCK cycle time	$t_{CYCCK}$	500	-	ns
SCK wait time between bytes	$t_{WAIT}$	1	-	us
SO data delay time	$t_{DDS}$	-	150	ns
SO data hold time	$t_{DHS}$	5	-	ns

Note: All timing is specified using 20% and 80% of  $V_{CC}$  as the reference points.

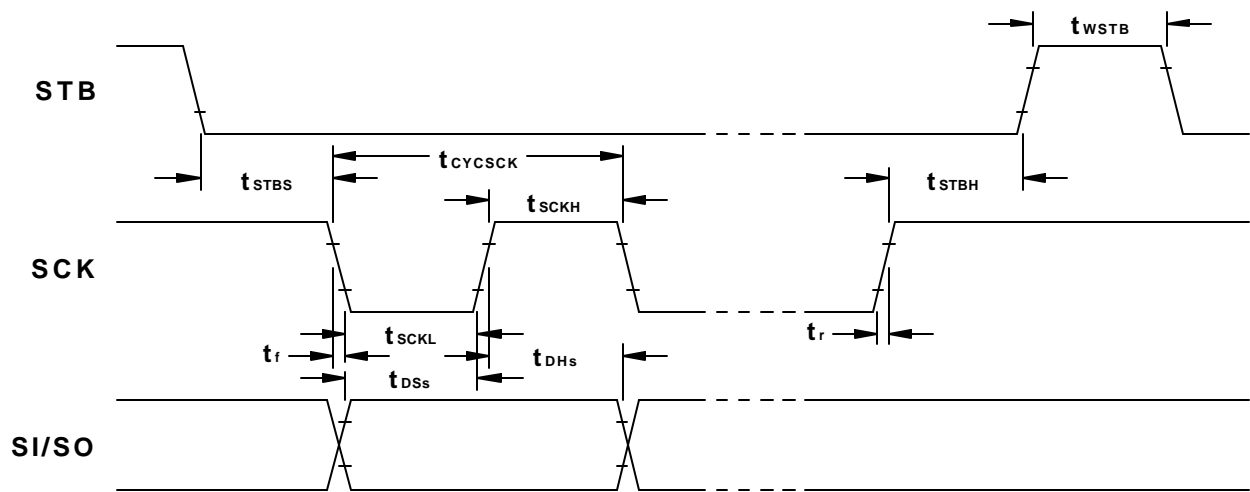

Figure 7. Synchronous Serial Interface Write Cycle Timing

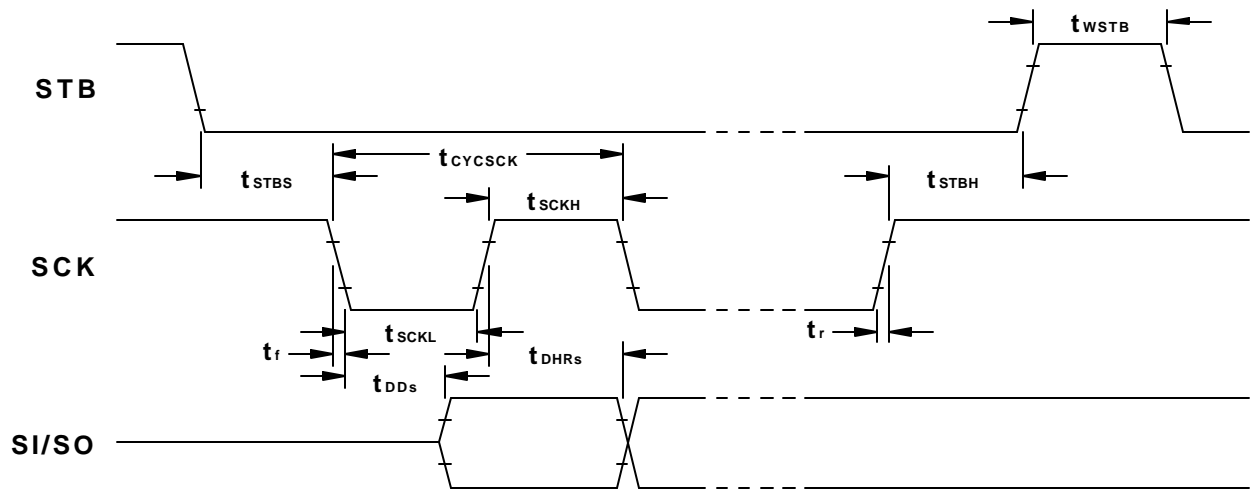

Figure 8. Synchronous Serial Interface Read Cycle Timing

## 4.0 MODES OF OPERATION

The following modes of operation are selectable via jumpers (see section 8.0 Jumper Settings).

### 4.1 PARALLEL INTERFACE MODES

In the parallel interface mode, 8-bit instructions and data are sent between the host and the modules using either 4-bit nibbles or 8-bit bytes. Nibbles are transmitted high nibble first on DB4-DB7 (DB0-DB3 are ignored) whereas bytes are transmitted on DB0-DB7. The Register Select (RS) control signal is used to identify DB0-DB7 as an instruction (low) or data (high).

#### 4.1.1 MOTOROLA M68-TYPE MODE

This mode uses the Read/Write (R/W) and Enable (E) control signals to transfer information. Instructions/data are written to the modules on the falling edge of E when R/W is low and are read from the modules after the rising edge of E when R/W is high.

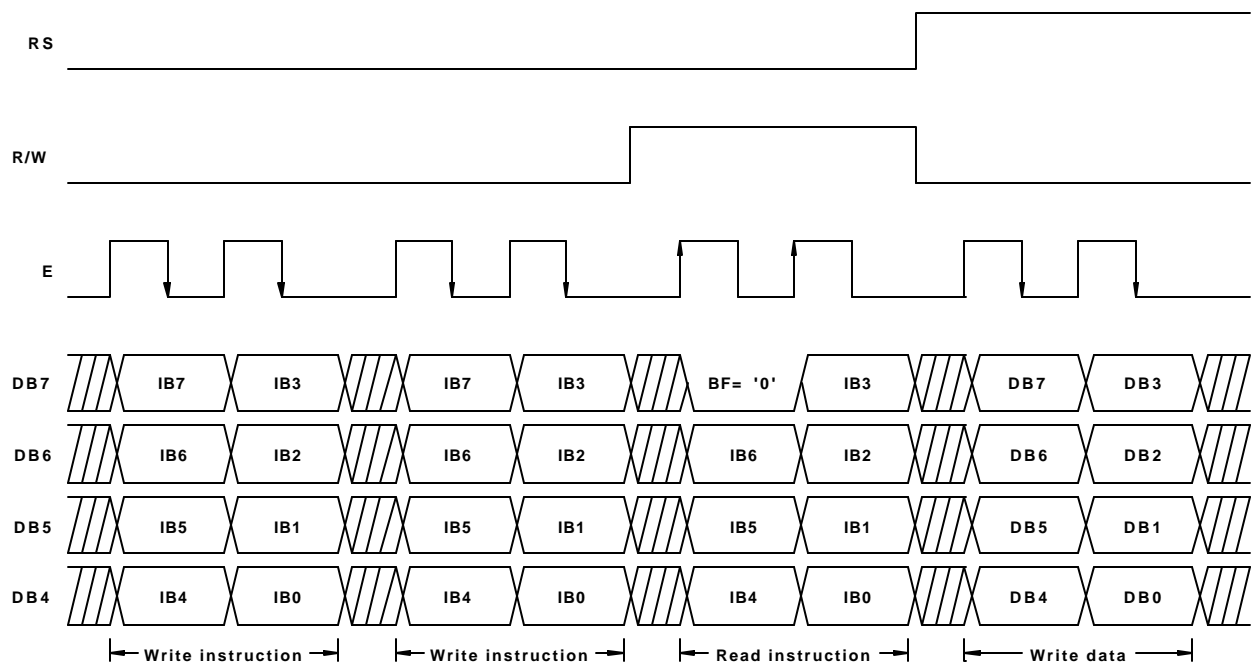
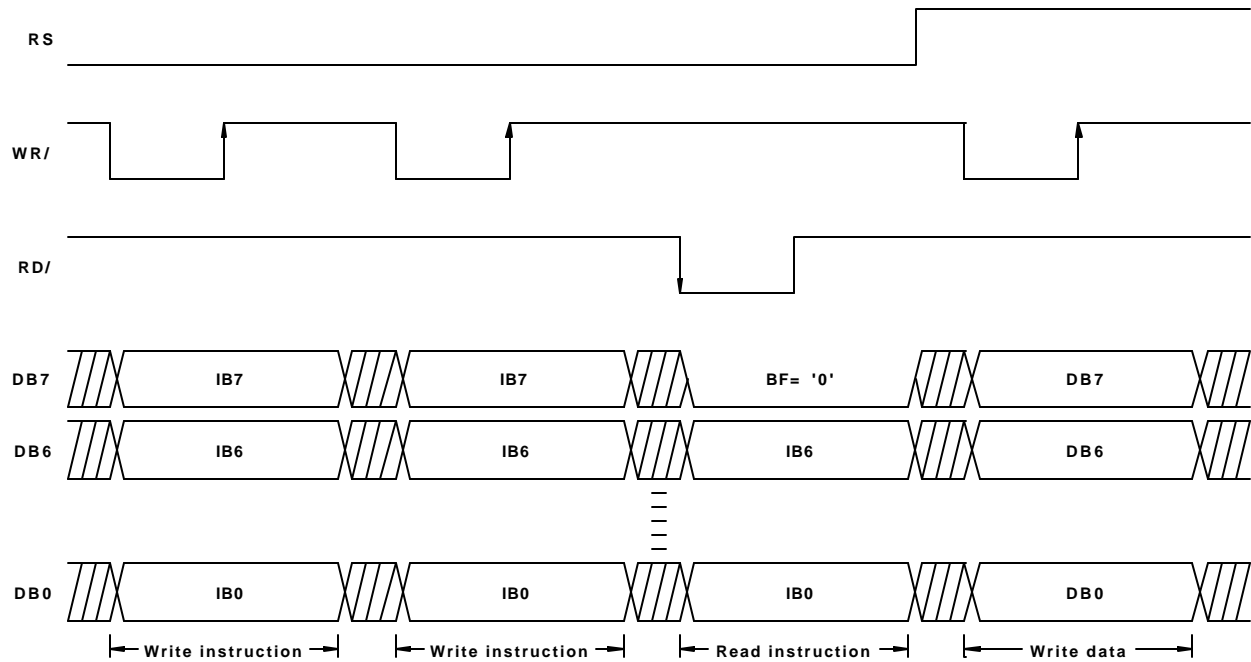

**Figure 9.** Typical 4-Bit Parallel Interface Sequence Using M68-Type Mode

STANDARD NAME		DOCUMENT NO.	REV. NO.	PAGE
		M0216SD-162SDAR2-1	03	12/24

### 4.1.2 INTEL I80-TYPE MODE

This mode uses the Read (RD/) and Write (WR/) control signals to transfer information. Instructions/data are written to the modules on the rising edge of WR/ and are read from the modules after the falling edge of RD/.



**Figure 10.** Typical 8-Bit Parallel Interface Sequence Using I80-Type Mode

### 4.2 SYNCHRONOUS SERIAL INTERFACE MODE

In the synchronous serial interface mode, instructions and data are sent between the host and the modules using 8-bit bytes. Two bytes are required per read/write cycle and are transmitted MSB first. The start byte contains 5 high bits, the Read/Write (R/W) control bit, the Register Select (RS) control bit, and a low bit. The following byte contains the instruction/data bits. The R/W bit determines whether the cycle is a read (high) or a write (low) cycle. The RS bit is used to identify the second byte as an instruction (low) or data (high).

This mode uses the Strobe (STB) control signal, Serial Clock (SCK) input, and Serial I/O (SI/SO) line to transfer information. In a write cycle, bits are clocked into the modules on the rising edge of SCK. In a read cycle, bits in the start byte are clocked into the modules on the rising edge of SCK. After the minimum wait time, each bit in the instruction/data byte can be read from the modules after each falling edge of SCK. Each read/write cycle begins on the falling edge of STB and ends on the rising edge. To be a valid read/write cycle, the STB must go high at the end of the cycle.

STANDARD NAME		DOCUMENT NO.	REV. NO.	PAGE
		M0216SD-162SDAR2-1	03	13/24

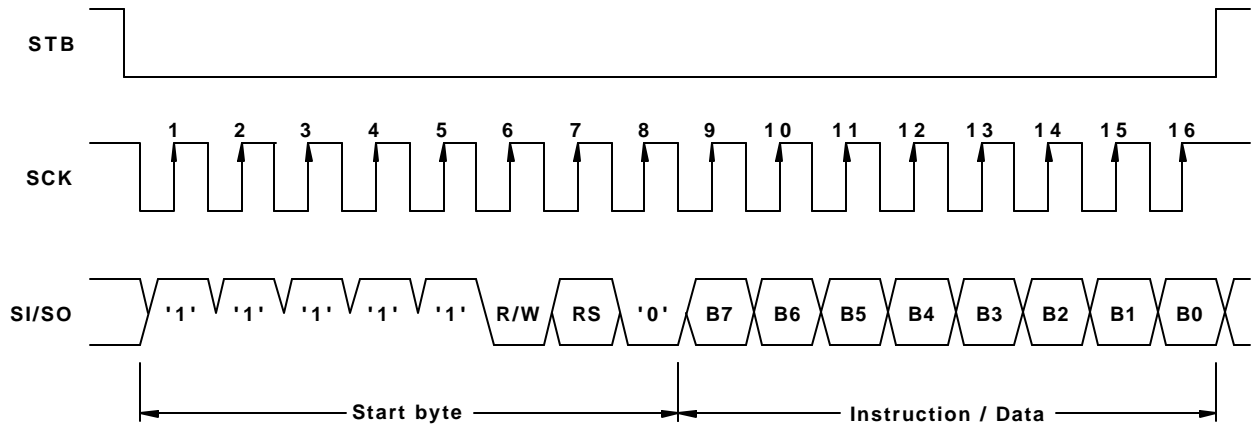

**Figure 11.** Typical Synchronous Serial Interface Write Cycle

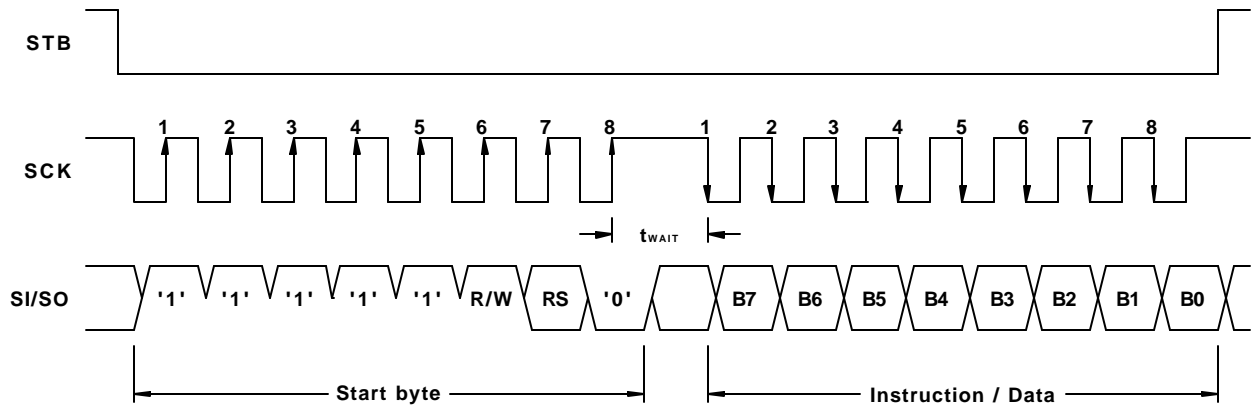

**Figure 12.** Typical Synchronous Serial Interface Read Cycle

### 4.3 RESET MODES

The modules are reset automatically at power-up by an internal R-C circuit. However, an external reset mode can also be selected when using one of the parallel interface modes (this option is not available when using the synchronous serial interface mode). This mode allows the modules to be reset by setting the Reset (RST/) input low.

STANDARD NAME		DOCUMENT NO.	REV. NO.	PAGE
		M0216SD-162SDAR2-1	03	14/24

## 5.0 CHARACTER FONT TABLES

UPPER NIBBLE / LOWER NIBBLE	0000	0001	0010	0011	0100	0101	0110	0111	1000	1001	1010	1011	1100	1101	1110	1111
0000	CG RAM (1)	!	0	A	P	'	R	A	E	-	3	E	0	P		
0001	CG RAM (2)	!	1	A	a	A	a	a	a	7	7	7	7	7	7	7
0010	CG RAM (3)	!"	2	B	b	B	b	B	b	4	4	4	4	4	4	4
0011	CG RAM (4)	!"#	3	C	c	C	c	C	c	5	5	5	5	5	5	5
0100	CG RAM (5)	!"#\$	4	D	d	D	d	D	d	6	6	6	6	6	6	6
0101	CG RAM (6)	!"#\$%	5	E	e	E	e	E	e	8	8	8	8	8	8	8
0110	CG RAM (7)	!"#\$%&	6	F	f	F	f	F	f	9	9	9	9	9	9	9
0111	CG RAM (8)	!"#\$%&'	7	G	g	G	g	G	g	0	0	0	0	0	0	0
1000	CG RAM (1)	!"#\$%&'(	8	H	h	H	h	H	h	1	1	1	1	1	1	1
1001	CG RAM (2)	!"#\$%&'( )	9	I	i	I	i	I	i	2	2	2	2	2	2	2
1010	CG RAM (3)	!"#\$%&'( ) *	0	J	j	J	j	J	j	3	3	3	3	3	3	3
1011	CG RAM (4)	!"#\$%&'( ) * +	1	K	k	K	k	K	k	4	4	4	4	4	4	4
1100	CG RAM (5)	!"#\$%&'( ) * + ,	2	L	l	L	l	L	l	5	5	5	5	5	5	5
1101	CG RAM (6)	!"#\$%&'( ) * + , -	3	M	m	M	m	M	m	6	6	6	6	6	6	6
1110	CG RAM (7)	!"#\$%&'( ) * + , - .	4	N	n	N	n	N	n	7	7	7	7	7	7	7
1111	CG RAM (8)	!"#\$%&'( ) * + , - . /	5	O	o	O	o	O	o	8	8	8	8	8	8	8

STANDARD  
NAME



DOCUMENT NO.

REV. NO.

PAGE

M0216SD-162SDAR2-1

03

15/24

## 6.0 FUNCTIONAL DESCRIPTION

### 6.1 ADDRESS COUNTER (AC)

#### 6.1.1 SINGLE LINE DISPLAYS

The AC stores the address of the data being written to and read from DDRAM or CGRAM. The AC increments by 1 (overflows from 4FH to 00H) or decrements by 1 (underflows from 00H to 4FH) after each DDRAM access. The AC increments by 1 (overflows from 3FH to 00H) or decrements by 1 (underflows from 00H to 3FH) after each CGRAM access. When addressing DDRAM, the value in the AC also represents the cursor position.

#### 6.1.2 MULTIPLE LINE DISPLAYS

The AC stores the address of the data being written to and read from DDRAM or CGRAM. The AC increments by 1 (overflows from 27H to 40H and from 67H to 00H) or decrements by 1 (underflows from 40H to 27H and from 00H to 67H) after each DDRAM access. The AC increments by 1 (overflows from 3FH to 00H) or decrements by 1 (underflows from 00H to 3FH) after each CGRAM access. When addressing DDRAM, the value in the AC also represents the cursor position.

### 6.2 DISPLAY DATA RAM (DDRAM)

#### 6.2.1 SINGLE LINE DISPLAYS

The DDRAM stores the character code of each character being displayed on the VFD. Valid DDRAM addresses are 00H to 4FH. DDRAM not being used for display characters can be used as general purpose RAM. The tables below show the relationship between the DDRAM address and the character position on the VFD before and after a display shift (with the number of display lines set to 1).

#### 6.2.2 MULTIPLE LINE DISPLAYS

The DDRAM stores the character code of each character being displayed on the VFD. Valid DDRAM addresses are 00H to 27H and 40H to 67H. DDRAM not being used for display characters can be used as general purpose RAM. The tables below show the relationship between the DDRAM address and the character position on the VFD before and after a display shift (with the number of display lines set to 2).

STANDARD NAME		DOCUMENT NO.	REV. NO.	PAGE
		M0216SD-162SDAR2-1	03	16/24



### 6.3 DISPLAY SHIFT DETAIL

Relationship before a display shift (non-shifted):

	1	2	3	4	5	6	7	8	9	10	11	12	13	14	15	16
1	00	01	02	03	04	05	06	07	08	09	0A	0B	0C	0D	0E	0F
2	40	41	42	43	44	45	46	47	48	49	4A	4B	4C	4D	4E	4F

Relationship after a display shift to the left:

	1	2	3	4	5	6	7	8	9	10	11	12	13	14	15	16
1	01	02	03	04	05	06	07	08	09	0A	0B	0C	0D	0E	0F	10
2	41	42	43	44	45	46	47	48	49	4A	4B	4C	4D	4E	4F	50

Relationship after a display shift to the right:

	1	2	3	4	5	6	7	8	9	10	11	12	13	14	15	16
1	27	00	01	02	03	04	05	06	07	08	09	0A	0B	0C	0D	0E
2	67	40	41	42	43	44	45	46	47	48	49	4A	4B	4C	4D	4E

## 6.4 CHARACTER GENERATOR RAM (CGRAM)

The CGRAM stores the pixel information (1 = pixel on, 0 = pixel off) for the eight user-definable 5x8 characters. Valid CGRAM addresses are 00H to 3FH. CGRAM not being used to define characters can be used as general purpose RAM (lower 5 bits only). Character codes 00H to 07H (or 08H to 0FH) are assigned to the user-definable characters (see section 5.0 Character Font Tables). The table below shows the relationship between the character codes, CGRAM addresses, and CGRAM data for each user-definable character.

Character code								CGRAM address					CGRAM data									
D7	D6	D5	D4	D3	D2	D1	D0	A5	A4	A3	A2	A1	A0	D7	D6	D5	D4	D3	D2	D1	D0	
0	0	0	0	X	0	0	0	0	0	0	0	0	0	X	X	X	0	1	1	1	1	CGRAM (1)
																		0	0	0	0	
																		0	0	0	1	
																		0	0	1	0	
																		0	0	1	0	
																		0	1	0	0	
																		0	0	0	0	
																		1	1	1	1	
																		0	0	0	0	
0	0	0	0	X	0	0	1	0	0	1	0	0	0	X	X	X	0	1	1	1	1	CGRAM (2)
																		0	0	0	0	
																		0	0	0	0	
																		0	0	0	0	
																		1	1	1	0	
																		0	0	0	0	
																		0	0	0	0	
																		1	1	1	1	
																		0	0	0	0	
0	0	0	0	X	1	1	1	1	1	1	0	0	0	X	X	X	0	1	1	1	0	CGRAM (8)
																		0	0	0	1	
																		0	0	0	0	
																		0	0	0	0	
																		0	0	0	0	
																		0	0	0	0	
																		0	0	0	0	
																		0	0	0	1	
																		0	1	1	0	

x = don't care

## 6.5 INSTRUCTIONS

Instruction	RS	R/W	DB7	DB6	DB5	DB4	DB3	DB2	DB1	DB0
Clear display	0	0	0	0	0	0	0	0	0	1
Cursor home	0	0	0	0	0	0	0	0	1	x
Entry mode set	0	0	0	0	0	0	0	1	I/D	S
Display on/off control	0	0	0	0	0	0	1	D	C	B
Cursor/display shift	0	0	0	0	0	1	S/C	R/L	x	x
Function set	0	0	0	0	1	DL	N	x	BR1	BR0
CGRAM address set	0	0	0	1	CGRAM address					
DDRAM address set	0	0	1	DDRAM address						
Address counter read	0	1	BF=0	AC contents						
DDRAM or CGRAM write	1	0	Write data							
DDRAM or CGRAM read	1	1	Read data							

x = don't care

STANDARD NAME:



DOCUMENT NO.

REV. NO.

PAGE

M0216SD-162SDAR2-1

03

18/24

### 6.5.1 CLEAR DISPLAY

RS	R/W	DB7	DB6	DB5	DB4	DB3	DB2	DB1	DB0
0	0	0	0	0	0	0	0	0	1

This instruction clears the display (without affecting the contents of CGRAM) by performing the following:

- 1) Fills all DDRAM locations with character code 20H (character code for a space).
- 2) Sets the AC to DDRAM address 00H (i.e. sets cursor position to 00H).
- 3) Returns the display to the non-shifted position.
- 4) Sets the I/D bit to 1.

### 6.5.2 CURSOR HOME

RS	R/W	DB7	DB6	DB5	DB4	DB3	DB2	DB1	DB0
0	0	0	0	0	0	0	0	1	x

x = don't care

This instruction returns the cursor to the home position (without affecting the contents of DDRAM or CGRAM) by performing the following:

- 1) Sets the AC to DDRAM address 00H (i.e. sets cursor position to 00H).
- 2) Returns the display to the non-shifted position.

### 6.5.3 ENTRY MODE SET

RS	R/W	DB7	DB6	DB5	DB4	DB3	DB2	DB1	DB0
0	0	0	0	0	0	0	1	I/D	S

This instruction selects whether the AC (cursor position) increments or decrements after each DDRAM or CGRAM access and determines the direction the information on the display shifts after each DDRAM write. The instruction also enables or disables display shifts after each DDRAM write (information on the display does not shift after a DDRAM read or CGRAM access). DDRAM, CGRAM, and AC contents are not affected by this instruction.

I/D = 0: The AC decrements after each DDRAM or CGRAM access. If S = 1, the information on the display shifts to the right by one character position after each DDRAM write.

I/D = 1: The AC increments after each DDRAM or CGRAM access. If S = 1, the information on the display shifts to the left by one character position after each DDRAM write.

S = 0: The display shift function is disabled.

S = 1: The display shift function is enabled.

STANDARD NAME		DOCUMENT NO.	REV. NO.	PAGE
		M0216SD-162SDAR2-1	03	19/24

## 6.5.4 DISPLAY ON/OFF CONTROL

RS	R/W	DB7	DB6	DB5	DB4	DB3	DB2	DB1	DB0
0	0	0	0	0	0	1	D	C	B

This instruction selects whether the display and cursor are on or off and selects whether or not the character at the current cursor position blinks. DDRAM, CGRAM, and AC contents are not affected by this instruction.

D = 0: The display is off (display blank).

D = 1: The display is on (contents of DDRAM displayed).

C = 0: The cursor is off.

C = 1: The cursor is on (8<sup>th</sup> row of pixels).

B = 0: The blinking character function is disabled.

B = 1: The blinking character function is enabled (a character with all pixels on will alternate with the character displayed at the current cursor position at about a 1Hz rate with a 50% duty cycle).

## 6.5.5 CURSOR/DISPLAY SHIFT

RS	R/W	DB7	DB6	DB5	DB4	DB3	DB2	DB1	DB0
0	0	0	0	0	1	S/C	R/L	x	x

x = don't care

This instruction increments or decrements the AC (cursor position) and shifts the information on the display one character position to the left or right without accessing DDRAM or CGRAM. DDRAM and CGRAM contents are not affected by this instruction. If the AC was addressing CGRAM prior to this instruction, the AC will be addressing DDRAM after this instruction. However, if the AC was addressing DDRAM prior to this instruction, the AC will still be addressing DDRAM after this instruction.

S/C	R/L	AC contents (cursor position)	Information on the display
0	0	Decrements by one	No change
0	1	Increments by one	No change
1	0	Decrements by one	Shifts one character position to the left
1	1	Increments by one	Shifts one character position to the right

## 6.5.6 FUNCTION SET

RS	R/W	DB7	DB6	DB5	DB4	DB3	DB2	DB1	DB0
0	0	0	0	1	DL	N	x	BR1	BR0

x = don't care

This instruction sets the width of the data bus for the parallel interface modes, the number of display lines, and the luminance level (brightness) of the VFD. It must be the first command sent after any reset. DDRAM, CGRAM, and AC contents are not affected by this instruction.

DL = 0: Sets the data bus width for the parallel interface modes to 4-bit (DB7-DB4).

DL = 1: Sets the data bus width for the parallel interface modes to 8-bit (DB7-DB0).

N = 0: Sets the number of display lines to 1 (this setting is not recommended for multiple line displays).

N = 1: Sets the number of display lines to 2 (this setting is not recommended for single line displays).

BR1, BR0 = 0,0: Sets the luminance level to 100%.

0,1: Sets the luminance level to 75%.

1,0: Sets the luminance level to 50%.

1,1: Sets the luminance level to 25%.

## 6.5.7 CGRAM ADDRESS SET

RS	R/W	DB7	DB6	DB5	DB4	DB3	DB2	DB1	DB0
0	0	0	1	CGRAM address					

This instruction places the 6-bit CGRAM address specified by DB5-DB0 into the AC (cursor position). Subsequent data writes (reads) will be to (from) CGRAM. DDRAM and CGRAM contents are not affected by this instruction.

## 6.5.8 DDRAM ADDRESS SET

RS	R/W	DB7	DB6	DB5	DB4	DB3	DB2	DB1	DB0
0	0	1	DDRAM address						

This instruction places the 7-bit DDRAM address specified by DB6-DB0 into the AC (cursor position). Subsequent data writes (reads) will be to (from) DDRAM. DDRAM and CGRAM contents are not affected by this instruction.

STANDARD NAME		DOCUMENT NO.	REV. NO.	PAGE
		M0216SD-162SDAR2-1	03	21/24

### 6.5.9 ADDRESS COUNTER READ

RS	R/W	DB7	DB6	DB5	DB4	DB3	DB2	DB1	DB0
0	1	BF=0	AC contents						

This instruction reads the current 7-bit address from the AC on DB6-DB0 and the busy flag (BF) bit (always 0) on DB7. DDRAM, CGRAM, and AC contents are not affected by this instruction. Because the BF is always 0, the host never has to read the BF bit to determine if the modules are busy before sending data or instructions. Therefore, data and instructions can be sent to the modules continuously according to the E, WR/, and SCK cycle times specified in section 3.7 AC Timing Specifications. Due to this feature, the execution times for each instruction are not specified.

### 6.5.10 DDRAM OR CGRAM WRITE

RS	R/W	DB7	DB6	DB5	DB4	DB3	DB2	DB1	DB0
1	0	Write data							

This instruction writes the 8-bit data byte on DB7-DB0 into the DDRAM or CGRAM location addressed by the AC. The most recent DDRAM or CGRAM Address Set instruction determines whether the write is to DDRAM or CGRAM. This instruction also increments or decrements the AC and shifts the display according to the I/D and S bits set by the Entry Mode Set instruction.

### 6.5.11 DDRAM OR CGRAM READ

RS	R/W	DB7	DB6	DB5	DB4	DB3	DB2	DB1	DB0
1	1	Read data							

This instruction reads the 8-bit data byte from the DDRAM or CGRAM location addressed by the AC on DB7-DB0. The most recent DDRAM or CGRAM Address Set instruction determines whether the read is from DDRAM or CGRAM. This instruction also increments or decrements the AC and shifts the display according to the I/D and S bits set by the Entry Mode Set instruction. Before sending this instruction, a DDRAM or CGRAM Address Set instruction should be executed to set the AC to the desired DDRAM or CGRAM address to be read.

STANDARD NAME		DOCUMENT NO.	REV. NO.	PAGE
		M0216SD-162SDAR2-1	03	22/24

## 6.6 RESET CONDITIONS

After either a power-up reset or an external reset, the modules initialize to the following conditions:

- 1) All DDRAM locations are set to 20H (character code for a space).
- 2) The AC is set to DDRAM address 00H (i.e. sets cursor position to 00H).
- 3) The relationship between DDRAM addresses and character positions on the VFD is set to the non-shifted position.
- 4) Entry Mode Set instruction bits:
  - I/D = 1: The AC increments after each DDRAM or CGRAM access.
  - S = 0: The display shift function is disabled.
- 5) Display On/Off Control instruction bits:
  - D = 0: The display is off (display blank).
  - C = 0: The cursor is off.
  - B = 0: The blinking character function is disabled.
- 6) Function Set instruction bits:
  - DL = 1: Sets the data bus width for the parallel interface modes to 8-bit (DB7-DB0).
  - N = 1(0): Number of display lines set to 2 for multiple line displays (number of display lines set to 1 for single line displays).
  - BR1, BR0 = 0,0: Sets the luminance level to 100%.

Note that the function set command must be the first instruction sent to the module after any reset.

### 6.6.1 INITIALIZATION

The modules can be initialized by using instructions if the modules are not reset according to the reset timing detailed in Section 3.7.1 (Reset Timing). After any reset, the function set command must be the first instruction sent to the module.

STANDARD NAME		DOCUMENT NO.	REV. NO.	PAGE
		M0216SD-162SDAR2-1	03	23/24

## 7.0 CONNECTOR INTERFACE

Pin NO.	Serial	Paralle (Intel)	Parallel (Motorola)	Pin NO.	Serial	Paralle (Intel)	Parallel (Motorola)
1	GND	GND	GND	2	VCC	VCC	VCC
3	SI/S0	NC or RST/	NC or RST/	4	STB	RS	RS
5	NC	WR/	R/W	6	SCK	RD/	E
7	NC	DB0	DB0	8	NC	DB1	DB1
9	NC	DB2	DB2	10	NC	DB3	DB3
11	NC	DB4	DB4	12	NC	DB5	DB5
13	NC	DB6	DB6	14	NC	DB7	DB7

## 8.0 Soldering Land Function

Some soldering lands are prepared on the tear side of PCB, to set operating mode of the Display module. A soldering iron is required to short soldering lands.

1. parallel data transfer mode is selected

J6	J7	J2	J3	FUNCTION	
Open	Short	*	Open	i80 type	MPU type Selection
Short	Open	*	Open	M68 type	
		Open	Open	Pin #3: No connection	External Reset Section
		Short	Open	Pin #3: /RESET	

2. serial data or parallel data transfer mode set

J5	J3	J2	FUNCTION
Open	Open		Parallel data Transfer mode
Short	Short	Open	Serial data Transfer mode

STANDARD  
NAME



DOCUMENT NO.  
M0216SD-162SDAR2-1

REV. NO.  
03

PAGE  
24/24





Компания «ЭлектроПласт» предлагает заключение долгосрочных отношений при поставках импортных электронных компонентов на взаимовыгодных условиях!

Наши преимущества:

- Оперативные поставки широкого спектра электронных компонентов отечественного и импортного производства напрямую от производителей и с крупнейших мировых складов;
- Поставка более 17-ти миллионов наименований электронных компонентов;
- Поставка сложных, дефицитных, либо снятых с производства позиций;
- Оперативные сроки поставки под заказ (от 5 рабочих дней);
- Экспресс доставка в любую точку России;
- Техническая поддержка проекта, помощь в подборе аналогов, поставка прототипов;
- Система менеджмента качества сертифицирована по Международному стандарту ISO 9001;
- Лицензия ФСБ на осуществление работ с использованием сведений, составляющих государственную тайну;
- Поставка специализированных компонентов (Xilinx, Altera, Analog Devices, Intersil, Interpoint, Microsemi, Aeroflex, Peregrine, Syfer, Eurofarad, Texas Instrument, Miteq, Cobham, E2V, MA-COM, Hittite, Mini-Circuits, General Dynamics и др.);

Помимо этого, одним из направлений компании «ЭлектроПласт» является направление «Источники питания». Мы предлагаем Вам помощь Конструкторского отдела:

- Подбор оптимального решения, техническое обоснование при выборе компонента;
- Подбор аналогов;
- Консультации по применению компонента;
- Поставка образцов и прототипов;
- Техническая поддержка проекта;
- Защита от снятия компонента с производства.



#### Как с нами связаться

**Телефон:** 8 (812) 309 58 32 (многоканальный)

**Факс:** 8 (812) 320-02-42

**Электронная почта:** [org@eplast1.ru](mailto:org@eplast1.ru)

**Адрес:** 198099, г. Санкт-Петербург, ул. Калинина, дом 2, корпус 4, литера А.