



SOT Temperature Sensors with Period/Frequency Output

MAX6576/MAX6577

General Description

The MAX6576/MAX6577 are low-cost, low-current temperature sensors with a single-wire output. The MAX6576 converts the ambient temperature into a square wave with a period proportional to absolute temperature ($^{\circ}\text{K}$). The MAX6577 converts the ambient temperature into a square wave with a frequency proportional to absolute temperature. The MAX6576 offers accuracy of $\pm 3^{\circ}\text{C}$ at $+25^{\circ}\text{C}$, $\pm 4.5^{\circ}\text{C}$ at $+85^{\circ}\text{C}$, and $\pm 5^{\circ}\text{C}$ at $+125^{\circ}\text{C}$. The MAX6577 offers accuracy of $\pm 3^{\circ}\text{C}$ at $+25^{\circ}\text{C}$, $\pm 3.5^{\circ}\text{C}$ at $+85^{\circ}\text{C}$, and $\pm 4.5^{\circ}\text{C}$ at $+125^{\circ}\text{C}$.

Both devices feature a single-wire output that minimizes the number of pins necessary to interface with a microprocessor. The period/frequency range of the output square wave can be selected by hard-wiring the two time-select pins (TS0, TS1) to either V_{DD} or GND. The MAX6576/MAX6577 are available in space-saving 6-pin SOT23 packages.

Applications

Critical μP and μC Temperature Monitoring
 Portable Battery-Powered Equipment
 Cell Phones
 Battery Packs
 Hard Drives/Tape Drives
 Networking and Telecom Equipment
 Medical Equipment
 Automotive

Pin Configuration

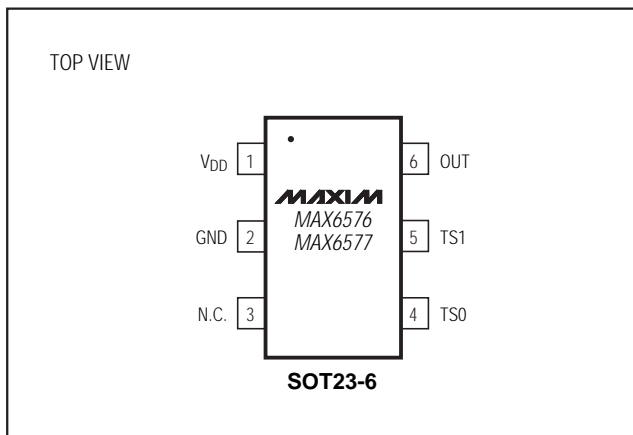

Features

- ◆ Simple Single-Wire Output
- ◆ Two Output Types Available
 - Temperature to Period (μs) (MAX6576)
 - Temperature to Frequency (Hz) (MAX6577)
- ◆ $\pm 0.8^{\circ}\text{C}$ Accuracy at $+25^{\circ}\text{C}$ ($\pm 3^{\circ}\text{C}$ max)
- ◆ No External Components
- ◆ Operates from $+2.7\text{V}$ to $+5.5\text{V}$ Supply Voltage
- ◆ Low $140\mu\text{A}$ Typical Supply Current
- ◆ Standard Operating Temperature Range: -40°C to $+125^{\circ}\text{C}$
- ◆ Small 6-Pin SOT23 Package

Ordering Information

PART	TEMP. RANGE	PIN-PACKAGE	SOT TOP MARK
MAX6576ZUT	-40°C to $+125^{\circ}\text{C}$	6 SOT23	AABI
MAX6577ZUT	-40°C to $+125^{\circ}\text{C}$	6 SOT23	AABJ

Typical Operating Circuit

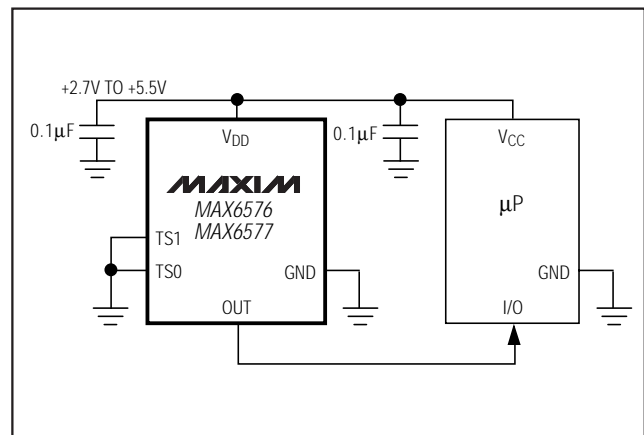

SOT Temperature Sensors with Period/Frequency Output

ABSOLUTE MAXIMUM RATINGS

Terminal Voltage (with respect to GND)

V_{DD} -0.3V to +6V

TS1, TS0, OUT-0.3V to ($V_{DD} + 0.3V$)

Input/Output Current, All Pins±20mA

Continuous Power Dissipation ($T_A = +70^\circ\text{C}$)

6-pin SOT23 (derate 7.10mW/ $^\circ\text{C}$ above +70 $^\circ\text{C}$).....571mW

Operating Temperature Range-40 $^\circ\text{C}$ to +125 $^\circ\text{C}$

Storage Temperature Range.....-65 $^\circ\text{C}$ to +150 $^\circ\text{C}$

Lead Temperature (soldering, 10sec)+300 $^\circ\text{C}$

Stresses beyond those listed under "Absolute Maximum Ratings" may cause permanent damage to the device. These are stress ratings only, and functional operation of the device at these or any other conditions beyond those indicated in the operational sections of the specifications is not implied. Exposure to absolute maximum rating conditions for extended periods may affect device reliability.

ELECTRICAL CHARACTERISTICS

($V_{DD} = +2.7V$ to +5.5V, $T_A = -40^\circ\text{C}$ to +125 $^\circ\text{C}$, unless otherwise noted. Typical values are specified at $T_A = +25^\circ\text{C}$ and $V_{DD} = +5V$, unless otherwise noted.)

PARAMETER	SYMBOL	CONDITIONS		MIN	TYP	MAX	UNITS	
V_{DD} Range	V_{DD}			2.7		5.5	V	
Supply Current	I_{DD}	$V_{DD} = 5.5V$	$T_A = -40^\circ\text{C}$ to +85 $^\circ\text{C}$		140	250	μA	
			$T_A = -40^\circ\text{C}$ to +125 $^\circ\text{C}$			400		
Temperature Sensor Error (Note 1)		MAX6576	$T_A = -20^\circ\text{C}$	-7.5	±1.1	+7.5	$^\circ\text{C}$	
			$T_A = 0^\circ\text{C}$	-5.5	±0.9	+5.5		
			$T_A = +25^\circ\text{C}$	-3.0	±0.8	+3.0		
			$T_A = +85^\circ\text{C}$	-4.5	±0.5	+4.5		
			$T_A = +125^\circ\text{C}$	-5.0	±0.5	+5.0		
		MAX6577	$T_A = -20^\circ\text{C}$	-7.5	±1.1	+7.5	$^\circ\text{C}$	
			$T_A = 0^\circ\text{C}$	-6.5	±0.9	+6.5		
			$T_A = +25^\circ\text{C}$	-3.0	±0.8	+3.0		
			$T_A = +85^\circ\text{C}$	-3.5	±0.5	+3.5		
			$T_A = +125^\circ\text{C}$	-4.5	±0.5	+4.5		
Output Clock Period	t_{OUT}	MAX6576, T (temp) in $^\circ\text{K}$, Figure 1	$V_{TS1} = \text{GND}, V_{TS0} = \text{GND}$		10T		μs	
			$V_{TS1} = \text{GND}, V_{TS0} = V_{DD}$		40T			
			$V_{TS1} = V_{DD}, V_{TS0} = \text{GND}$		160T			
			$V_{TS1} = V_{DD}, V_{TS0} = V_{DD}$		640T			
Output Clock Frequency	f_{OUT}	MAX6577, T (temp) in $^\circ\text{K}$, Figure 2	$V_{TS1} = \text{GND}, V_{TS0} = \text{GND}$		4T		Hz	
			$V_{TS1} = \text{GND}, V_{TS0} = V_{DD}$		1T			
			$V_{TS1} = V_{DD}, V_{TS0} = \text{GND}$		T/4			
			$V_{TS1} = V_{DD}, V_{TS0} = V_{DD}$		T/16			
OUT Duty Cycle (Note 2)					0.5			
Time-Select Pin Logic Levels	V_{IL}					0.8	V	
	V_{IH}			2.3				
OUT Voltage	V_{OL}	$V_{DD} > 4.5V, I_{SINK} = 3.2\text{mA}$				0.4	V	
		$V_{DD} > 2.7V, I_{SINK} = 1.2\text{mA}$				0.3		
	V_{OH}	$V_{DD} > 4.5V, I_{SRC} = 800\mu\text{A}$		$V_{DD} - 1.5$				
		$V_{DD} > 2.7V, I_{SRC} = 500\mu\text{A}$		$0.8V_{DD}$				

Note 1: See the Temperature Accuracy histograms in the *Typical Operating Characteristics*.

Note 2: The output duty cycle is guaranteed to be 50% by an internal flip-flop.

SOT Temperature Sensors with Period/Frequency Output

Typical Operating Characteristics

(V_{DD} = +5V, T_A = +25°C, unless otherwise noted.)

MAX6576/MAX6577

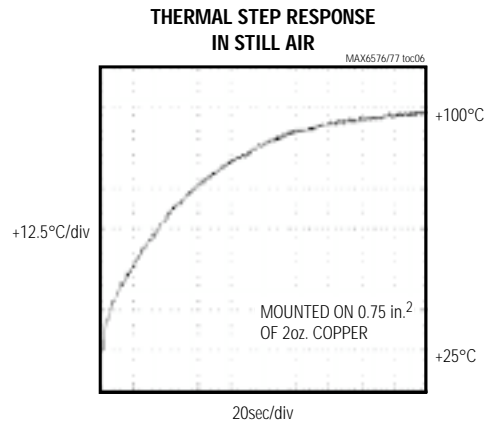
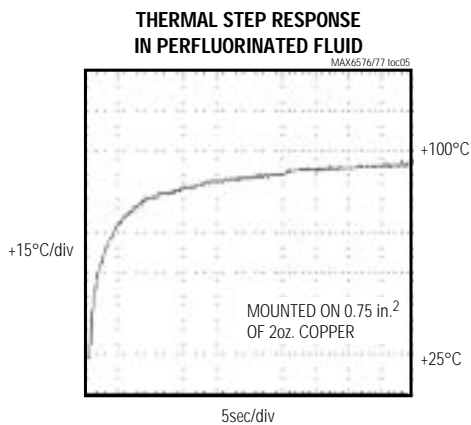
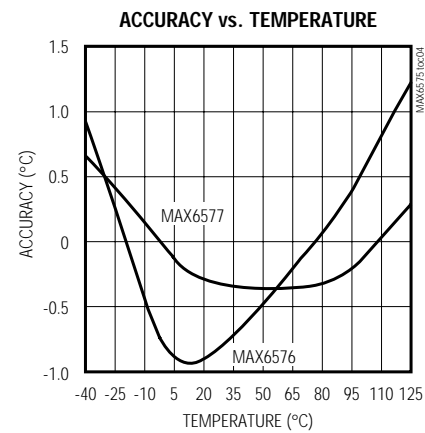
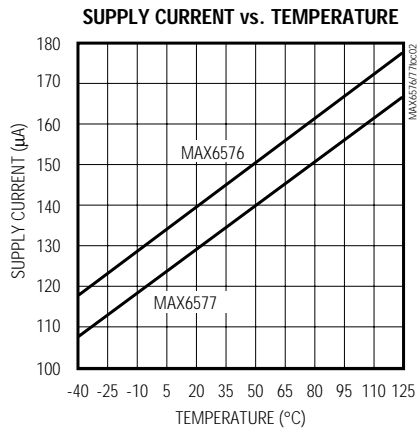
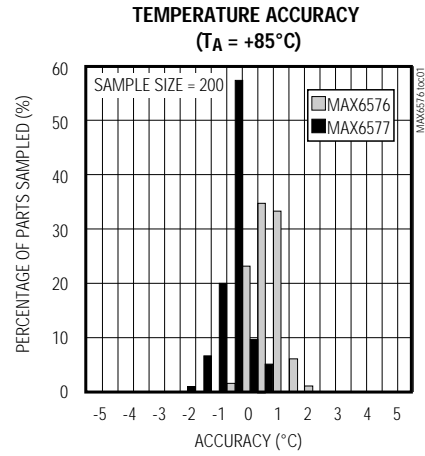
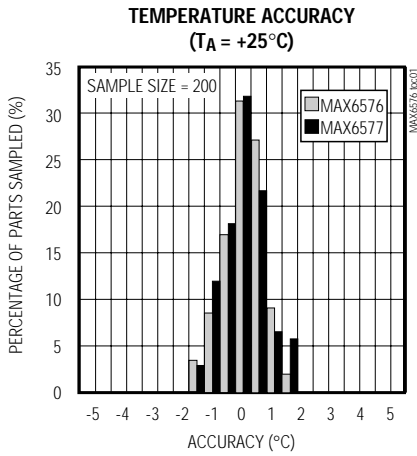

SOT Temperature Sensors with Period/Frequency Output

Pin Description

PIN	NAME	FUNCTION
1	V _{DD}	Positive Supply Voltage
2	GND	Ground
3	N.C.	No Connection. Connect pin to GND or leave open.
4, 5	TS1, TS0	Time-Select Pins. TS1 and TS0 set the temperature scale factor by connecting TS1 and TS0 to either V _{DD} or GND. See Tables 1 and 2.
6	OUT	Square-Wave Output with a Clock Period Proportional to Absolute Temperature (°K) (MAX6576)
		Square-Wave Output with a Clock Frequency Proportional to Absolute Temperature (°K) (MAX6577)

Table 1. MAX6576 Time-Select Pin Configuration

TS1	TS0	SCALAR MULTIPLIER (μs/°K)
GND	GND	10
GND	V _{DD}	40
V _{DD}	GND	160
V _{DD}	V _{DD}	640

Note: The temperature, in °C, may be calculated as follows:

$$T(^{\circ}\text{C}) = \frac{\text{period}(\mu\text{s})}{\text{scalar multiplier}(\mu\text{s}/^{\circ}\text{K})} - 273.15^{\circ}\text{K}$$

Table 2. MAX6577 Time-Select Pin Configuration

TS1	TS0	SCALAR MULTIPLIER (Hz/°K)
GND	GND	4
GND	V _{DD}	1
V _{DD}	GND	1/4
V _{DD}	V _{DD}	1/16

Note: The temperature, in °C, may be calculated as follows:

$$T(^{\circ}\text{C}) = \frac{\text{frequency}(\text{Hz})}{\text{scalar multiplier}(\text{Hz}/^{\circ}\text{K})} - 273.15^{\circ}\text{K}$$

Detailed Description

The MAX6576/MAX6577 low-cost, low-current (140μA typ) temperature sensors are ideal for interfacing with microcontrollers (μCs) or microprocessors (μPs). The MAX6576 converts ambient temperature into a 50% duty-cycle square wave with a period proportional to absolute temperature. The MAX6577 converts ambient temperature into a 50% duty-cycle square wave with a frequency proportional to absolute temperature. Time-select pins (TS1, TS0) permit the internal temperature-controlled oscillator (TCO) to be scaled by four preset multipliers. The MAX6576/MAX6577 feature a single-wire interface to minimize the number of port pins necessary for interfacing with a μP.

MAX6576 Characteristics

The MAX6576 temperature sensor converts temperature to period. The output of the device is a free-running, 50% duty-cycle square wave with a period that

is proportional to the absolute temperature (°K) of the device (Figure 1). The MAX6576 has a push/pull CMOS output with sharp edges. The speed of the output square wave can be selected by hard-wiring TS1 and TS0 as shown in Table 1. One of four scaled output periods can be selected using TS1 and TS0.

MAX6577 Characteristics

The MAX6577 temperature sensor converts temperature to frequency. The output of the device is a free-running, 50% duty-cycle square wave with a frequency that is proportional to the absolute temperature (°K) of the device (Figure 2). The MAX6577 has a push/pull CMOS output with sharp edges. The speed of the output square wave can be selected by hard-wiring TS1 and TS0 as shown in Table 2. One of four scaled output frequencies can be selected using TS1 and TS0.

SOT Temperature Sensors with Period/Frequency Output

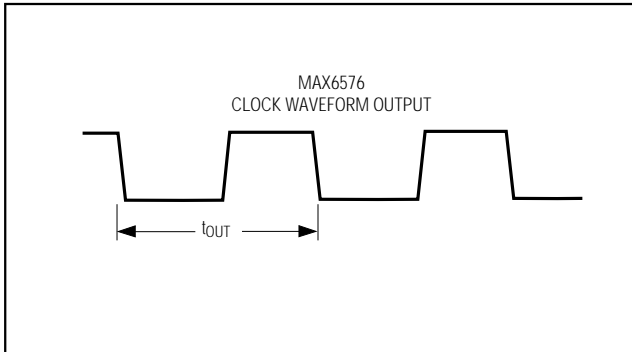

Figure 1. MAX6576 Timing Diagram

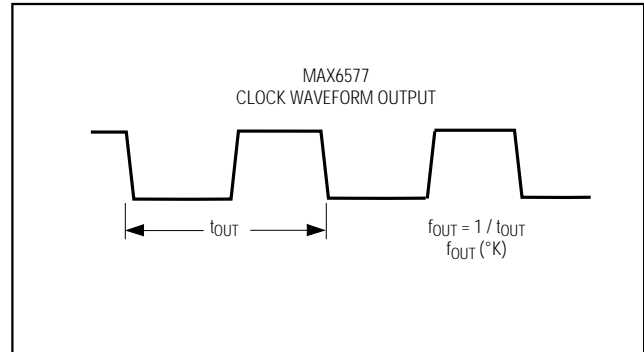

Figure 2. MAX6577 Timing Diagram

Applications Information

Quick-Look Circuits

Figure 3 shows a quick-look application circuit for the MAX6576 using a universal counter measuring period. TS1 and TS0 are both tied to ground to select a scalar multiplier of $10\mu s/^{\circ}K$. The MAX6576 converts the ambient temperature into a square wave with a period that is 10 times the absolute temperature of the device in μs . At room temperature, the universal counter will display approximately $2980\mu s$.

Figure 4 shows a quick-look application circuit for the MAX6577 using a universal counter measuring frequency. TS1 is tied to ground and TS0 is tied to V_{DD} to select a scalar multiplier of $1Hz/^{\circ}K$. The MAX6577 converts the ambient temperature into a square wave with a frequency that is equal to the absolute temperature of the device in Hertz. At room temperature, the universal counter will display approximately 298Hz.

Interfacing with a Microcontroller

Figure 5 shows the MAX6577 interfaced with an 8051 μC . In this example, TS1 is tied to ground and TS0 is

tied to V_{DD} to select a scalar multiplier of $1Hz/^{\circ}K$. The MAX6577 converts the ambient temperature into a square wave with a frequency that is equal to the absolute temperature of the device in Hertz. The 8051 μC reads the frequency of the square-wave output of the MAX6577 into Timer 0 and displays the temperature as degrees Celsius in binary on Port 1. Listing 1 provides the code for this application. The interface is similar for the MAX6576, except the μC will perform a period measurement.

Noise Considerations

The accuracy of the MAX6576/MAX6577 is susceptible to noise generated both internally and externally. The effects of external noise can be minimized by placing a $0.1\mu F$ ceramic bypass capacitor close to the supply pin of the devices. Internal noise is inherent in the operation of the devices and is detailed in Table 3. Internal averaging minimizes the effect of this noise when using longer scalar timeout multipliers. The effects of this noise are included in the overall accuracy of the devices as specified in the *Electrical Characteristics*.

SOT Temperature Sensors with Period/Frequency Output

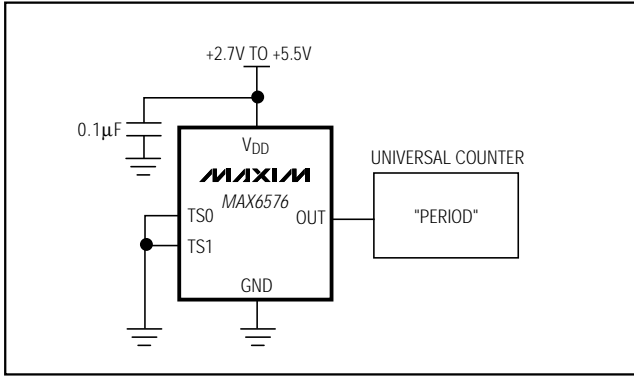

Figure 3. MAX6576 Quick-Look Circuit

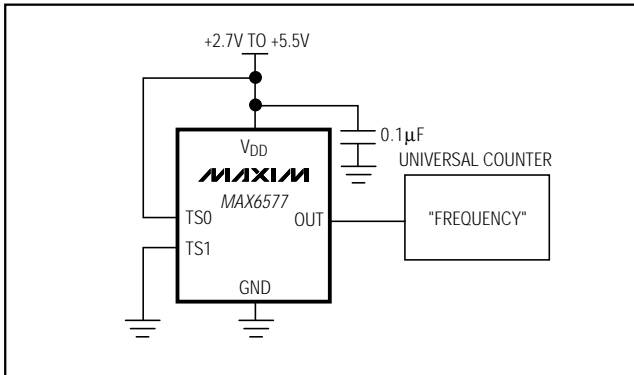

Figure 4. MAX6577 Quick-Look Circuit

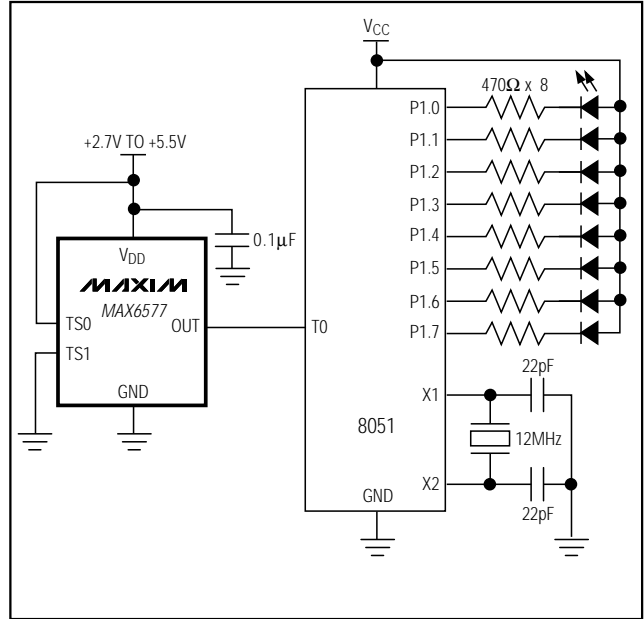

Figure 5. Interfacing with a µC

Chip Information
TRANSISTOR COUNT: 302

Table 3. Typical Peak Noise Amplitude

PARAMETER	MAX6576				MAX6577			
	10	40	160	640	4	1	1/4	1/16
Scalar Multiplier	10	40	160	640	4	1	1/4	1/16
Noise Amplitude (°C)	±0.38	±0.17	±0.11	±0.094	±0.13	±0.066	±0.040	±0.028

SOT Temperature Sensors with Period/Frequency Output

Listing 1. 8051 Code Example

```

;*****
; Demonstration and test code for MAX6577 Temp to Frequency
; Takes in temperature values from a sensor into timer 0
; and displays temp as degrees C in binary on port 1.
; example: room temp= 21 C, display 21 or 00010101 on P1
;*****
;EQUATES
TEMPH      EQU    10H                ;TEMPERATURE
TEMPL      EQU    11H
TICKS      EQU    12H                ;number of 50 ms- counts to 1 second

NEWT       BIT    00h                ;new temp flag- bit address in 20h
;MAIN
          ORG    0                    ;note one isr's used- timer overflow
          AJMP  BEGIN                 ;jump over isr's
          ORG    1BH                  ;TF1 ISR
TICK:     PUSH  ACC                   ;stash acc
          PUSH  PSW                   ;stash psw
; reload timer- 50 ms
          CLR   C                     ;clear for subb
          MOV   A,#0B0H               ;latency fix
          SUBB  A,TL1                 ;subtract timer low latency < 20
          MOV   TL1,A                 ;50 ms reload value- low
          MOV   TH1,#03CH             ;50 ms reload value- high
          DJNZ  TICKS,NORL            ;jump over counter code
          MOV   TICKS,#20              ;reload ticks
;read counter to temp1 and temp high if 1 second
GTAG:     MOV   A,TH0                 ;get timer high
          MOV   B,TL0                 ;grab timer low
          CJNE  A,TH0,GTAG            ;get again if rollover
          MOV   TEMPH,A               ;stash high
          MOV   TEMPL,B               ;stash low
          MOV   TH0,#0                ;zero counter
          MOV   TL0,#0                ;zero counter
          SETB  NEWT                  ;set data ready flag
NORL:     POP   PSW
          POP   ACC
          RETI                          ;done

BEGIN:     MOV   SP,#70h              ;set sp at 70H
;setup timers to do timing- t0 input, t1 timer 50 ms
          MOV   TMOD,#15H             ;t1 timer- t0 counter
          MOV   TH1,#03CH             ;50 ms reload value- high
          MOV   TL1,#0B0H             ;50 ms reload value- low
          MOV   TL0,#0                ;reset counter low
          MOV   TH0,#0                ;reset counter high
          MOV   TCON,#50H             ;start both timers
          MOV   TICKS,#20              ;20 x 50 ms = 1 sec
          MOV   IE,#88H               ;enable t1 ints and global
;
;inits done- measure
DOTMP:     CLR   NEWT                 ;clear data flag
WAITT:     JNB  NEWT,WAITT            ;wait for data

; temp is stored- display bin value of selected on P1

```

SOT Temperature Sensors with Period/Frequency Output

Listing 1. 8051 Code Example (continued)

```

; temp is in kelvin- subtract 273
MOV  A,TEMPL      ;get temp (K)
CLR  C             ;ready for subb
SUBB A,#011H      ;sub low byte of 273
MOV  TEMPL,A      ;stash back
MOV  A,TEMPH      ;get high byte for completeness
SUBB A,#01H       ;sub high byte and prop carry
MOV  TEMPH,A      ;stash

;display it
MOV  A,TEMPL      ;get temp (C)
CPL  A            ;compliment for led's- active low
MOV  P1,A         ;output it
JMP  DOTMP

END
    
```

Package Information

SYMBOL	MIN	MAX
A	0.90	1.45
A1	0.00	0.15
A2	0.90	1.30
b	0.35	0.50
C	0.08	0.20
D	2.80	3.00
E	2.60	3.00
E1	1.50	1.75
L	0.35	0.55
e	0.95 REF	
a	0°	10°

NOTE:

1. ALL DIMENSIONS ARE IN MILLIMETERS.
2. FOOT LENGTH MEASURED AT INTERCEPT POINT BETWEEN DATUM A & LEAD SURFACE.
3. PACKAGE OUTLINE EXCLUSIVE OF MOLD FLASH & METAL BURR.
4. PACKAGE OUTLINE INCLUSIVE OF SOLDER PLATING.
5. PIN 1 IS LOWER LEFT PIN WHEN READING TOP MARK FROM LEFT TO RIGHT. (SEE EXAMPLE TOP MARK)
6. PIN 1 I.D. DOT IS 0.3 MM Ø MIN. LOCATED ABOVE PIN 1.

MAXIM		
<small>PROPRIETARY INFORMATION</small>		
<small>TITLE:</small>		
PACKAGE OUTLINE, SOT23, 6L		
<small>APPROVAL</small>	<small>DOCUMENT CONTROL NO.</small>	<small>REV</small>
	21-0058	D 1/1

6LSOT.EPS

Maxim cannot assume responsibility for use of any circuitry other than circuitry entirely embodied in a Maxim product. No circuit patent licenses are implied. Maxim reserves the right to change the circuitry and specifications without notice at any time.

8 Maxim Integrated Products, 120 San Gabriel Drive, Sunnyvale, CA 94086 408-737-7600



Компания «ЭлектроПласт» предлагает заключение долгосрочных отношений при поставках импортных электронных компонентов на взаимовыгодных условиях!

Наши преимущества:

- Оперативные поставки широкого спектра электронных компонентов отечественного и импортного производства напрямую от производителей и с крупнейших мировых складов;
- Поставка более 17-ти миллионов наименований электронных компонентов;
- Поставка сложных, дефицитных, либо снятых с производства позиций;
- Оперативные сроки поставки под заказ (от 5 рабочих дней);
- Экспресс доставка в любую точку России;
- Техническая поддержка проекта, помощь в подборе аналогов, поставка прототипов;
- Система менеджмента качества сертифицирована по Международному стандарту ISO 9001;
- Лицензия ФСБ на осуществление работ с использованием сведений, составляющих государственную тайну;
- Поставка специализированных компонентов (Xilinx, Altera, Analog Devices, Intersil, Interpoint, Microsemi, Aeroflex, Peregrine, Syfer, Eurofarad, Texas Instrument, Miteq, Cobham, E2V, MA-COM, Hittite, Mini-Circuits, General Dynamics и др.);

Помимо этого, одним из направлений компании «ЭлектроПласт» является направление «Источники питания». Мы предлагаем Вам помощь Конструкторского отдела:

- Подбор оптимального решения, техническое обоснование при выборе компонента;
- Подбор аналогов;
- Консультации по применению компонента;
- Поставка образцов и прототипов;
- Техническая поддержка проекта;
- Защита от снятия компонента с производства.



Как с нами связаться

Телефон: 8 (812) 309 58 32 (многоканальный)

Факс: 8 (812) 320-02-42

Электронная почта: org@eplast1.ru

Адрес: 198099, г. Санкт-Петербург, ул. Калинина, дом 2, корпус 4, литера А.