

**MHz RANGE CRYSTAL UNIT**

Built-in thermistor

FA-128S

- Nominal frequency range : 38.4 MHz
- External dimensions : 2.0 × 1.6 × 0.9 mm
- Overtone order : Fundamental
- Applications : Mobile phone, Bluetooth, W-LAN
ISM band radio, Clock for MPU
GPS, Smart phone

Product Number (please contact us)
FA-128S : X1E000361xxxx17

Actual size

**Specifications (characteristics)**

Item	Symbol	Specifications	Conditions / Remarks
Nominal frequency range	f_nom	38.4 MHz	Fundamental Please contact us about available frequencies.
Storage temperature range	T_stg	-40 °C to +125 °C	Storage as single product.
Operating temperature range	T_use	-40 °C to +85 °C	
Level of drive	DL	100 μW Max.	Recommended: 1 to 100 μW
Frequency tolerance	f_tol	±10 × 10 ⁻⁶ *1	Please contact us about reference temperature. Please contact us for inquiries.
Frequency versus temperature characteristics	f_tem	±12 × 10 ⁻⁶ *1	-30 °C to +85 °C Please contact us for inquiries.
Load capacitance	CL	6 pF to ∞	Please specify.
Motional resistance (ESR)	R1	60 Ω Max.	-30 °C to +85 °C
Frequency aging	f_age	±1 × 10 ⁻⁶ / year Max.	+25 °C, First year
Thermistor resistance	—	Please contact us about specifications.	
Thermistor B constant	—		

*1 Please contact us for available frequency tolerances as they are dependent upon the nominal frequency.

Product name FA-128S 38.400000MHz 7.0 +10.0-10.0
(Standard form) ① ② ③ ④①Model ②Frequency ③Load capacitance(pF) ④Frequency tolerance(× 10⁻⁶, +25 °C)

In addition to the above mentioned specification item, please specify frequency temperature characteristics and operating temperature range in case of inquiry.

External dimensions

(Unit:mm)

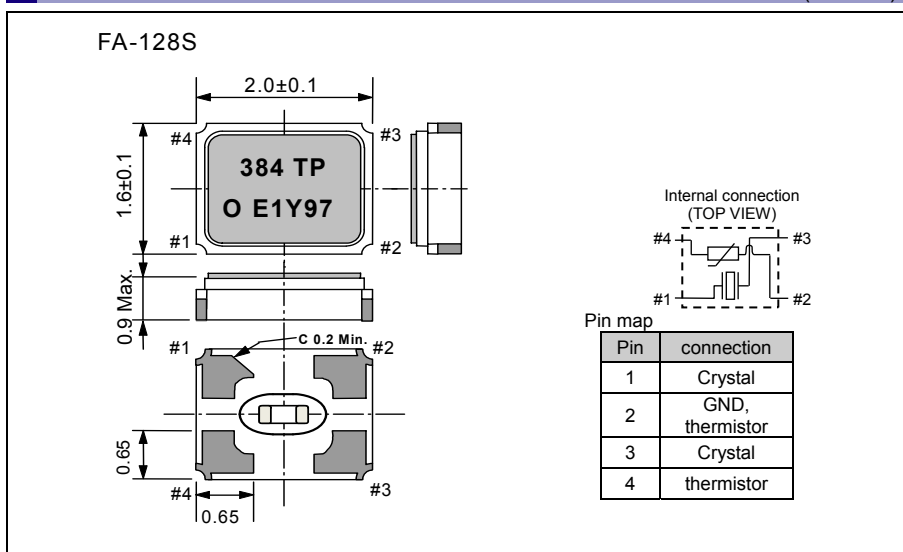
**Footprint (Recommended)**

(Unit:mm)

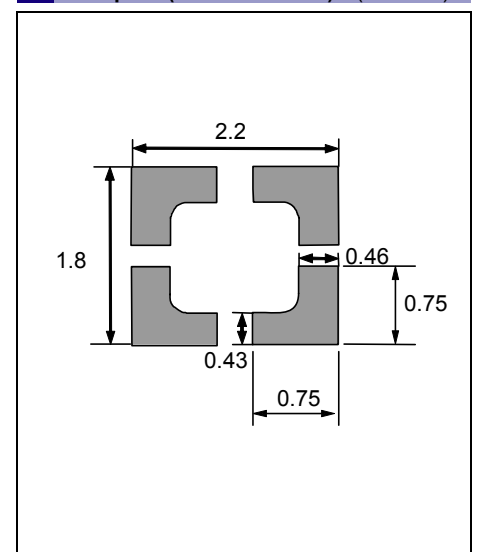

PROMOTION OF ENVIRONMENTAL MANAGEMENT SYSTEM CONFORMING TO INTERNATIONAL STANDARDS

At Seiko Epson, all environmental initiatives operate under the Plan-Do-Check-Action (PDCA) cycle designed to achieve continuous improvements. The environmental management system (EMS) operates under the ISO 14001 environmental management standard.

All of our major manufacturing and non-manufacturing sites, in Japan and overseas, completed the acquisition of ISO 14001 certification.

ISO 14000 is an international standard for environmental management that was established by the International Standards Organization in 1996 against the background of growing concern regarding global warming, destruction of the ozone layer, and global deforestation.

WORKING FOR HIGH QUALITY

In order provide high quality and reliable products and services than meet customer needs,

Seiko Epson made early efforts towards obtaining ISO9000 series certification and has acquired ISO9001 for all business establishments in Japan and abroad. We have also acquired ISO/TS 16949 certification that is requested strongly by major automotive manufacturers as standard.

ISO/TS16949 is the international standard that added the sector-specific supplemental requirements for automotive industry based on ISO9001.

► Explanation of the mark that are using it for the catalog

	► Pb free.
	► Complies with EU RoHS directive. *About the products without the Pb-free mark. Contains Pb in products exempted by EU RoHS directive. (Contains Pb in sealing glass, high melting temperature type solder or other.)
	► Designed for automotive applications such as Car Multimedia, Body Electronics, Remote Keyless Entry etc.
	► Designed for automotive applications related to driving safety (Engine Control Unit, Air Bag, ESC etc).

Notice

- This material is subject to change without notice.
- Any part of this material may not be reproduced or duplicated in any form or any means without the written permission of Seiko Epson.
- The information about applied data, circuitry, software, usage, etc. written in this material is intended for reference only. Seiko Epson does not assume any liability for the occurrence of customer damage or infringing on any patent or copyright of a third party. This material does not authorize the licensing for any patent or intellectual copyrights.
- When exporting the products or technology described in this material, you should comply with the applicable export control laws and regulations and follow the procedures required by such laws and regulations.
- You are requested not to use the products (and any technical information furnished, if any) for the development and/or manufacture of weapon of mass destruction or for other military purposes. You are also requested that you would not make the products available to any third party who may use the products for such prohibited purposes.
- These products are intended for general use in electronic equipment. When using them in specific applications that require extremely high reliability, such as the applications stated below, you must obtain permission from Seiko Epson in advance.
/ Space equipment (artificial satellites, rockets, etc.) / Transportation vehicles and related (automobiles, aircraft, trains, vessels, etc.) / Medical instruments to sustain life / Submarine transmitters / Power stations and related / Fire work equipment and security equipment / traffic control equipment / and others requiring equivalent reliability.
- All brands or product names mentioned herein are trademarks and/or registered trademarks of their respective.

Mouser Electronics

Authorized Distributor

Click to View Pricing, Inventory, Delivery & Lifecycle Information:

Epson:

[FA-128S 19.2000MF12Y-AG3](#) [FA-128S 19.2000MF12Y-AG0](#) [FA-128S 38.4000MF10Y-AG3](#)



Компания «ЭлектроПласт» предлагает заключение долгосрочных отношений при поставках импортных электронных компонентов на взаимовыгодных условиях!

Наши преимущества:

- Оперативные поставки широкого спектра электронных компонентов отечественного и импортного производства напрямую от производителей и с крупнейших мировых складов;
- Поставка более 17-ти миллионов наименований электронных компонентов;
- Поставка сложных, дефицитных, либо снятых с производства позиций;
- Оперативные сроки поставки под заказ (от 5 рабочих дней);
- Экспресс доставка в любую точку России;
- Техническая поддержка проекта, помощь в подборе аналогов, поставка прототипов;
- Система менеджмента качества сертифицирована по Международному стандарту ISO 9001;
- Лицензия ФСБ на осуществление работ с использованием сведений, составляющих государственную тайну;
- Поставка специализированных компонентов (Xilinx, Altera, Analog Devices, Intersil, Interpoint, Microsemi, Aeroflex, Peregrine, Syfer, Eurofarad, Texas Instrument, Miteq, Cobham, E2V, MA-COM, Hittite, Mini-Circuits, General Dynamics и др.);

Помимо этого, одним из направлений компании «ЭлектроПласт» является направление «Источники питания». Мы предлагаем Вам помощь Конструкторского отдела:

- Подбор оптимального решения, техническое обоснование при выборе компонента;
- Подбор аналогов;
- Консультации по применению компонента;
- Поставка образцов и прототипов;
- Техническая поддержка проекта;
- Защита от снятия компонента с производства.



Как с нами связаться

Телефон: 8 (812) 309 58 32 (многоканальный)

Факс: 8 (812) 320-02-42

Электронная почта: org@eplast1.ru

Адрес: 198099, г. Санкт-Петербург, ул. Калинина, дом 2, корпус 4, литера А.