

### General Description

The IDT8N3DV85 is a LVPECL Dual-Frequency Programmable VCXO with very flexible frequency and pull-range programming capabilities. The device uses IDT's fourth generation FemtoClock® NG technology for an optimum of high clock frequency and low phase noise performance. The device accepts 2.5V or 3.3V supply and is packaged in a small, lead-free (RoHS 6) 6-lead ceramic 5mm x 7mm x 1.55mm package.

The device can be factory-programmed to any two frequencies in the range of 15.476MHz to 866.67MHz and from 975MHz to 1,300MHz to the very high degree of frequency precision of 218Hz or better. The output frequency is selected by the FSEL pin. The extended temperature range supports wireless infrastructure, telecommunication and networking end equipment requirements.

### Features

- Fourth Generation FemtoClock® NG technology
- Programmable clock output frequency from 15.476MHz to 866.67MHz and from 975MHz to 1,300MHz
- Two factory-programmed output frequencies
- VCO frequency programming resolution is 218Hz and better
- Factory-programmable VCXO pull range and control voltage polarity
- VCXO pull range programmable from typical  $\pm 12.5$  to  $\pm 787.5$ ppm
- One 2.5V or 3.3V LVPECL clock output
- FSEL control input for frequency selection, LVCMOS/LVTTL compatible
- RMS phase jitter @ 622.08MHz (12kHz - 20MHz): 0.46ps (typical)
- RMS phase jitter @ 622.08MHz (50kHz - 80MHz): 0.47ps (typical)
- 2.5V or 3.3V supply voltage
- -40°C to 85°C ambient operating temperature
- Lead-free (RoHS 6) 6-lead ceramic 5mm x 7mm x 1.55mm package

### Block Diagram

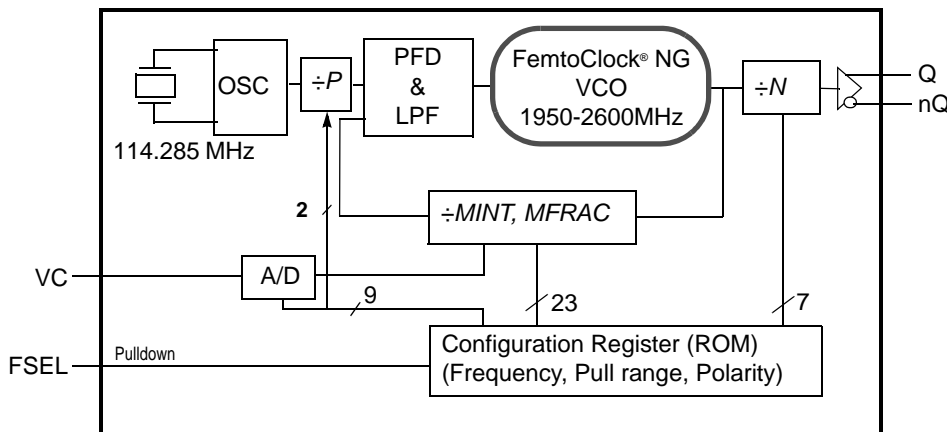

### Pin Assignment

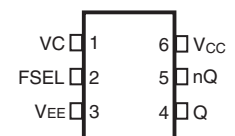

**IDT8N3DV85**  
 6-lead ceramic 5mm x 7mm x 1.55mm  
 package body  
 CD Package  
 Top View

## Pin Description and Characteristic Tables

**Table 1. Pin Descriptions**

Number	Name	Type		Description
1	VC	Input		VCXO Control Voltage input.
2	FSEL	Input	Pulldown	Frequency select pin. See Table 3A for function. LVCMOS/LVTTL interface levels.
3	V <sub>EE</sub>	Power		Negative power supply.
4, 5	Q, nQ	Output		Differential clock output. LVPECL interface levels.
6	V <sub>CC</sub>	Power		Positive power supply.

NOTE: *Pulldown* refers to internal input resistors. See Table 2, *Pin Characteristics*, for typical values.

**Table 2. Pin Characteristics**

Symbol	Parameter		Test Conditions	Minimum	Typical	Maximum	Units
C <sub>IN</sub>	Input Capacitance	FSEL			5.5		pF
		VC			10		pF
R <sub>PULLDOWN</sub>	Input Pulldown Resistor				50		kΩ

## Function Tables

**Table 3A. Frequency Selection**

Input	Operation
FSEL	
0 (default)	Frequency 0
1	Frequency 1

NOTE: Frequency 0 and 1 are factory-programmed by IDT. Any frequency combination within the available frequency range can be ordered. For order information, see *FemtoClock NG Ceramic-Package XO and VCXO Ordering Product Information* document. .

**Table 3B. Output Frequency Range**

15.476MHz to 866.67MHz
975MHz to 1,300MHz

NOTE: Supported output frequency range. The output frequency can be programmed to any frequency in this range and to a precision of 218Hz or better.

## Principles of Operation

The block diagram consists of the internal 3rd overtone crystal and oscillator which provide the reference clock  $f_{XTAL}$  of 114.285MHz. The PLL includes the FemtoClock® VCO along with the Pre-divider ( $P$ ), the feedback divider ( $M$ ) and the post divider ( $N$ ). The  $P$ ,  $M$ , and  $N$  dividers determine the output frequency based on the  $f_{XTAL}$  reference. The feedback divider is fractional supporting a huge number of output frequencies. Internal registers are used to hold up to two different factory pre-set configuration settings. The configuration is selected via the FSEL pin. Changing the FSEL control results in an immediate change of the output frequency to the selected register values. The  $P$ ,  $M$ , and  $N$  frequency configurations support an output frequency range 15.476MHz to 866.67MHz and 975MHz to 1,300MHz.

The devices use the fractional feedback divider with a delta-sigma modulator for noise shaping and robust frequency synthesis capability. The relatively high reference frequency minimizes phase noise generated by frequency multiplication and allows more efficient shaping of noise by the delta-sigma modulator. The output frequency is determined by the 2-bit pre-divider ( $P$ ), the feedback divider ( $M$ ) and the 7-bit post divider ( $N$ ). The feedback divider ( $M$ ) consists of both a 7-bit integer portion ( $MINT$ ) and an 18-bit fractional portion ( $MFRAC$ ) and provides the means for high-resolution frequency generation. The output frequency  $f_{OUT}$  is calculated by:

$$f_{OUT} = f_{XTAL} \cdot \frac{1}{P \cdot N} \cdot \left[ MINT + \frac{MFRAC + 0.5}{2^{18}} \right] \quad (1)$$

**Table 3A. Frequency Selection**

Input	
FSEL	Selects
0 (default)	Frequency 0
1	Frequency 1

## Frequency Configuration

An order code is assigned to each frequency configuration and the VCXO pull-range programmed by the factory (default frequencies). For more information on the available default frequencies and order codes, please see the Ordering Information Section in this document. For available order codes, see the *FemtoClock NG Ceramic-Package XO and VCXO Ordering Product Information* document.

For more information on programming capabilities of the device for custom frequency and pull-range configurations, see the *FemtoClock NG Ceramic 5x7 Module Programming Guide*.

## Absolute Maximum Ratings

NOTE: Stresses beyond those listed under *Absolute Maximum Ratings* may cause permanent damage to the device. These ratings are stress specifications only. Functional operation of product at these conditions or any conditions beyond those listed in the *DC Characteristics* or *AC Characteristics* is not implied. Exposure to absolute maximum rating conditions for extended periods may affect product reliability.

Item	Rating
Supply Voltage, $V_{CC}$	3.71V
Inputs, $V_I$	-0.5V to $V_{CC} + 0.5V$
Outputs, $I_O$ Continuous Current Surge Current	50mA 100mA
Package Thermal Impedance, $\theta_{JA}$	49.4°C/W (0 mps)
Storage Temperature, $T_{STG}$	-65°C to 150°C

## DC Electrical Characteristics

**Table 4A. Power Supply DC Characteristics,  $V_{CC} = 3.3V \pm 5\%$ ,  $V_{EE} = 0V$ ,  $T_A = -40^\circ C$  to  $85^\circ C$**

Symbol	Parameter	Test Conditions	Minimum	Typical	Maximum	Units
$V_{CC}$	Power Supply Voltage		3.135	3.3	3.465	V
$I_{EE}$	Power Supply Current			130	160	mA

**Table 4B. Power Supply DC Characteristics,  $V_{CC} = 2.5V \pm 5\%$ ,  $V_{EE} = 0V$ ,  $T_A = -40^\circ C$  to  $85^\circ C$**

Symbol	Parameter	Test Conditions	Minimum	Typical	Maximum	Units
$V_{CC}$	Power Supply Voltage		2.375	2.5	2.625	V
$I_{EE}$	Power Supply Current			120	155	mA

**Table 4C. LVPECL DC Characteristics,  $V_{CC} = 3.3V \pm 5\%$ ,  $V_{EE} = 0V$ ,  $T_A = -40^\circ C$  to  $85^\circ C$**

Symbol	Parameter	Test Conditions	Minimum	Typical	Maximum	Units
$V_{OH}$	Output High Voltage; NOTE 1		$V_{CC} - 1.4$		$V_{CC} - 0.9$	V
$V_{OL}$	Output Low Voltage; NOTE 1		$V_{CC} - 2.0$		$V_{CC} - 1.7$	V
$V_{SWING}$	Peak-to-Peak Output Voltage Swing		0.6		1.0	V

NOTE 1: Outputs terminated with  $50\Omega$  to  $V_{CC} - 2V$ .

**Table 4D. LVPECL DC Characteristics,  $V_{CC} = 2.5V \pm 5\%$ ,  $V_{EE} = 0V$ ,  $T_A = -40^\circ C$  to  $85^\circ C$**

Symbol	Parameter	Test Conditions	Minimum	Typical	Maximum	Units
$V_{OH}$	Output High Voltage; NOTE 1		$V_{CC} - 1.4$		$V_{CC} - 0.9$	V
$V_{OL}$	Output Low Voltage; NOTE 1		$V_{CC} - 2.0$		$V_{CC} - 1.5$	V
$V_{SWING}$	Peak-to-Peak Output Voltage Swing		0.4		1.0	V

NOTE 1: Outputs terminated with  $50\Omega$  to  $V_{CC} - 2V$ .

**Table 4E. LVCMOS/LVTTL DC Characteristic,  $V_{CC} = 3.3V \pm 5\%$  or  $2.5V \pm 5\%$ ,  $V_{EE} = 0V$ ,  $T_A = -40^{\circ}C$  to  $85^{\circ}C$** 

Symbol	Parameter		Test Conditions	Minimum	Typical	Maximum	Units
$V_{IH}$	Input High Voltage		$V_{CC} = 3.3V$	2		$V_{CC} + 0.3$	V
			$V_{CC} = 2.5V$	1.7		$V_{CC} + 0.3$	V
$V_{IL}$	Input Low Voltage		$V_{CC} = V_{IN} = 3.465V$	-0.3		0.7	V
			$V_{CC} = V_{IN} = 2.5V$	-0.3		0.7	V
$I_{IH}$	Input High Current	FSEL	$V_{CC} = V_{IN} = 3.465V$ or $2.625V$			150	$\mu A$
$I_{IL}$	Input Low Current	FSEL	$V_{CC} = 3.465V$ or $2.625V$ , $V_{IN} = 0V$	-5			$\mu A$

## AC Electrical Characteristics

**Table 5A. AC Characteristics,  $V_{CC} = 3.3V \pm 5\%$  or  $2.5V \pm 5\%$ ,  $T_A = -40^\circ C$  to  $85^\circ C$**

Symbol	Parameter	Test Conditions	Minimum	Typical	Maximum	Units
$f_{OUT}$	Output Frequency Q, nQ		15.476		866.67	MHz
			975		1,300	MHz
$f_I$	Initial Accuracy	Measured @ $25^\circ C$ , $V_C = V_{CC}/2$			$\pm 10$	ppm
$f_S$	Temperature Stability	Option code = A or B			$\pm 100$	ppm
		Option code = E or F			$\pm 50$	ppm
		Option code = K or L			$\pm 20$	ppm
$f_A$	Aging	Frequency drift over 10 year life			$\pm 3$	ppm
		Frequency drift over 15 year life			$\pm 5$	ppm
$f_T$	Total Stability	Option code A, B (10 year life)			$\pm 113$	ppm
		Option code E, F (10 year life)			$\pm 63$	ppm
		Option code K, L (10 year life)			$\pm 33$	ppm
$f_{jit(cc)}$	Cycle-to-Cycle Jitter; NOTE 1	622.08MHz		6	12	ps
$f_{jit(per)}$	RMS Period Jitter			2	3	ps
$f_{jit}(\emptyset)$	RMS Phase Jitter (Random); NOTE 2	622.08MHz, Integration Range: 12kHz - 20MHz		0.46	0.71	ps
$f_{jit}(\emptyset)$	RMS Phase Jitter (Random); NOTE 2	622.08MHz, Integration Range: 50kHz - 80MHz		0.47	0.72	ps
$f_{jit}(\emptyset)$	RMS Phase Jitter (Random); NOTE 2,3,4 $f_{XTAL} = 114.285MHz$	$500MHz < f_{OUT} \leq 1300MHz$		0.44	0.77	ps
		$125MHz < f_{OUT} \leq 500MHz$		0.52	0.90	ps
		$15MHz \leq f_{OUT} \leq 125MHz$		0.74	1.2	ps
$\Phi_N(100)$	Single-side band phase noise, 100Hz from Carrier	622.08MHz		-68		dBc/H z
$\Phi_N(1k)$	Single-side band phase noise, 1kHz from Carrier	622.08MHz		-89		dBc/H z
$\Phi_N(10k)$	Single-side band phase noise, 10kHz from Carrier	622.08MHz		-113		dBc/H z
$\Phi_N(100k)$	Single-side band phase noise, 100kHz from Carrier	622.08MHz		-118		dBc/H z
$\Phi_N(1M)$	Single-side band phase noise, 1MHz from Carrier	622.08MHz		-127		dBc/H z
$\Phi_N(10M)$	Single-side band phase noise, 10MHz from Carrier	622.08MHz		-137		dBc/H z
$t_R / t_F$	Output Rise/Fall Time	20% to 80%	80		500	ps
odc	Output Duty Cycle		45		55	%
PSNR	Power Supply Noise Rejection	50mV sinusoidal Noise 1kHz - 50MHz		-71.2		dBc
$t_{STARTUP}$	Device Startup Time after Power-up				10	ms
$t_{SET}$	Output Frequency Settling Time after FSEL value is changed				1	ms

Notes continued on next page.

NOTE: Electrical parameters are guaranteed over the specified ambient operating temperature range, which is established when the device is mounted in a test socket with maintained transverse airflow greater than 500lfm. The device will meet specifications after thermal equilibrium has been reached under these conditions.

NOTE: XTAL parameters (initial accuracy, temperature stability, aging and total stability) are guaranteed by manufacturing.

NOTE: Characterized with  $V_C = V_{CC}/2$

NOTE 1: This parameter is defined in accordance with JEDEC standard 65.

NOTE 2: Refer to the phase noise plot.

NOTE 3: Please see the FemtoClock Ceramic 5x7 Modules Programming Guide for more information on PLL feedback modes and the optimum configuration for phase noise.

**Table 5B. VCXO Control Voltage Input ( $V_C$ ) Characteristics,  $V_{CC} = 3.3V \pm 5\%$  or  $2.5V \pm 5\%$ ,  $T_A = -40^\circ C$  to  $85^\circ C$**

Symbol	Parameter	Test Conditions	Minimum	Typical	Maximum	Units
$K_V$	Oscillator Gain, NOTE 1, 2, 3	$V_{CC} = 3.3V$	7.57		477.27	ppm/V
	Oscillator Gain, NOTE 1, 2, 3	$V_{CC} = 2.5V$	10		630	ppm/V
$L_{VC}$	Control Voltage Linearity; NOTE 4	BSL Variation	-5	$\pm 0.4$	+5	%
BW	Modulation Bandwidth			100		kHz
$Z_{VC}$	VC Input Impedance			500		k $\Omega$
$V_{C_{NOM}}$	Nominal Control Voltage			$V_{CC}/2$		V
$V_C$	Control Voltage Tuning Range; NOTE 4		0		$V_{CC}$	V

NOTE 1:  $V_C = 0V$  to  $V_{CC}$ . Oscillator gain is programmed by IDT. Gain =  $(25 \cdot n) \div V_{CC}$  and is in the range of  $n=1$  to  $n = 63$ .

NOTE 2: Nominal oscillator gain: Pull range from Table 3B divided by the control voltage tuning range of 3.3V.

NOTE 3: For best phase noise performance, use the lowest  $K_V$  that meets the requirements of the application.

NOTE 4: BSL = Best Straight Line Fit: Variation of the output frequency vs. control voltage  $V_C$ , in percent.  $V_C$  ranges from 10% to 90%  $V_{CC}$ .



### Typical Phase Noise at 622.08MHz (12kHz - 20MHz)

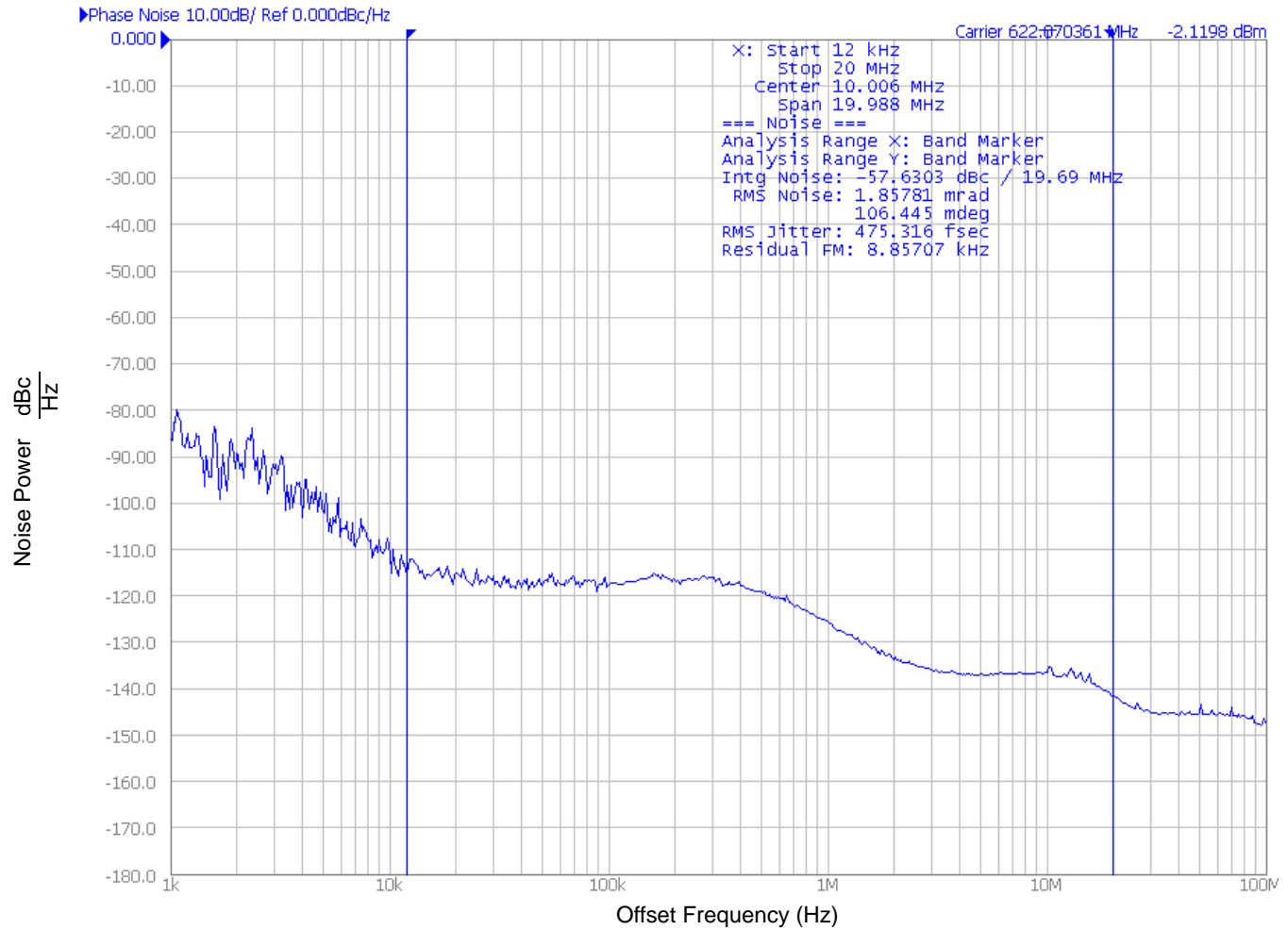

### Parameter Measurement Information

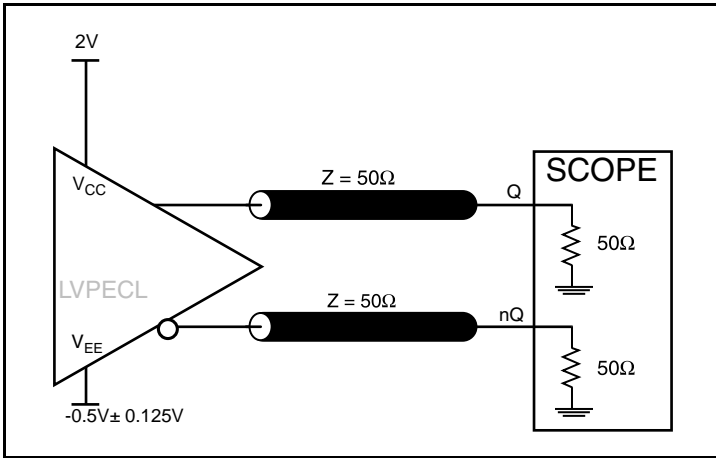

2.5V LVPECL Output Load AC Test Circuit

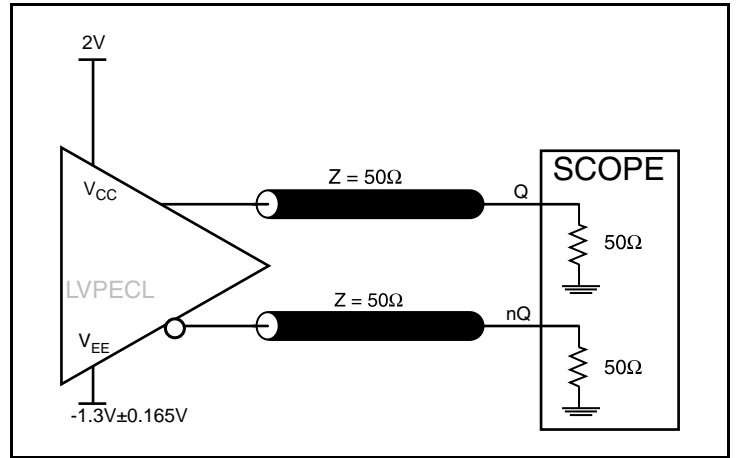

3.3V LVPECL Output Load AC Test Circuit

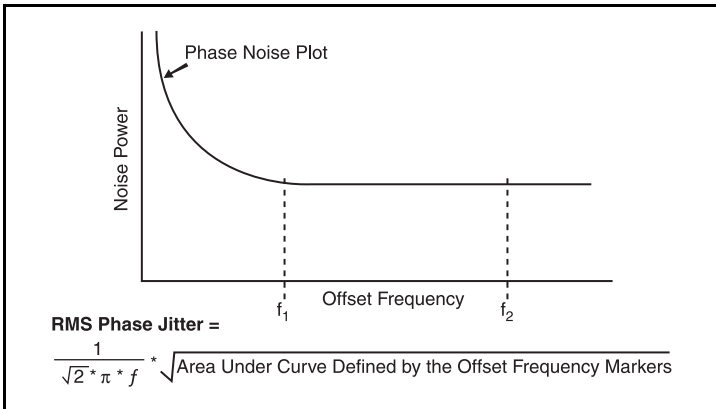

RMS Phase Jitter

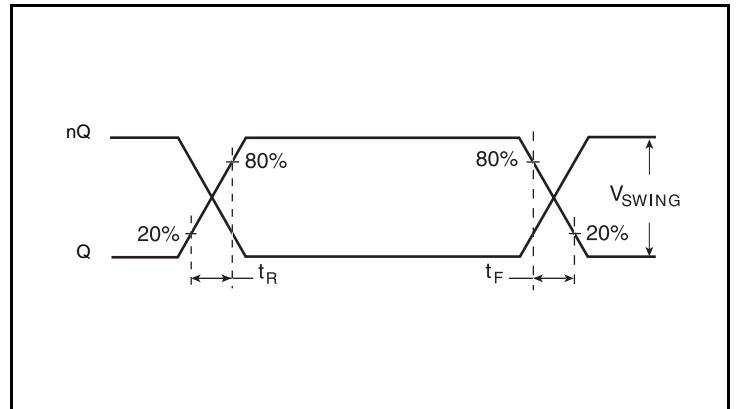

Output Rise/Fall Time

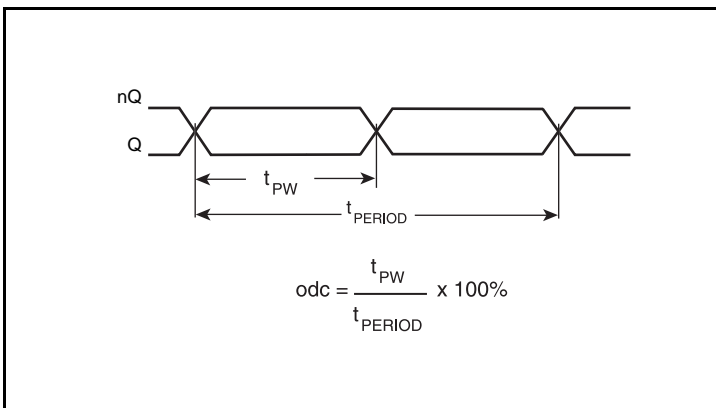

Output Duty Cycle/Pulse Width/Period

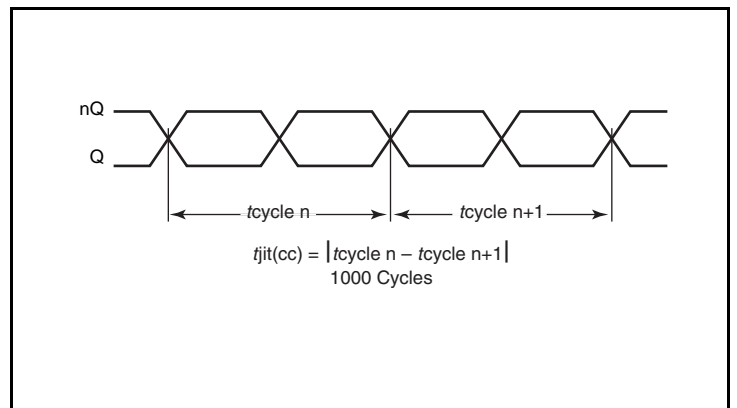

Cycle-to-Cycle Jitter

## Parameter Measurement Information, continued

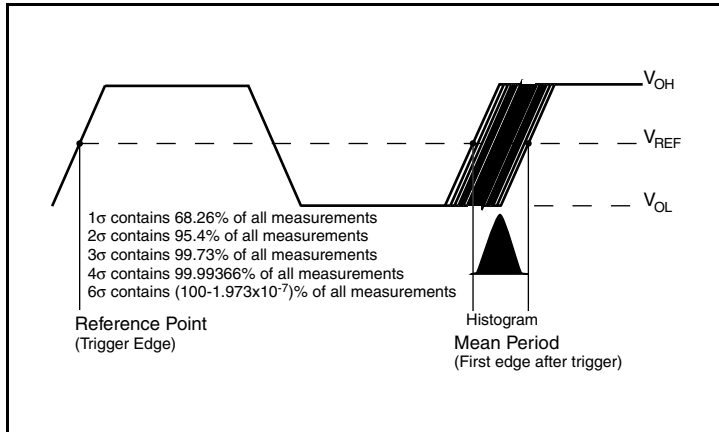

RMS Period Jitter

## Applications Information

### Termination for 3.3V LVPECL Outputs

The clock layout topology shown below is a typical termination for LVPECL outputs. The two different layouts mentioned are recommended only as guidelines.

The differential outputs are low impedance follower outputs that generate ECL/LVPECL compatible outputs. Therefore, terminating resistors (DC current path to ground) or current sources must be used for functionality. These outputs are designed to drive 50Ω

transmission lines. Matched impedance techniques should be used to maximize operating frequency and minimize signal distortion.

Figures 1A and 1B show two different layouts which are recommended only as guidelines. Other suitable clock layouts may exist and it would be recommended that the board designers simulate to guarantee compatibility across all printed circuit and clock component process variations.

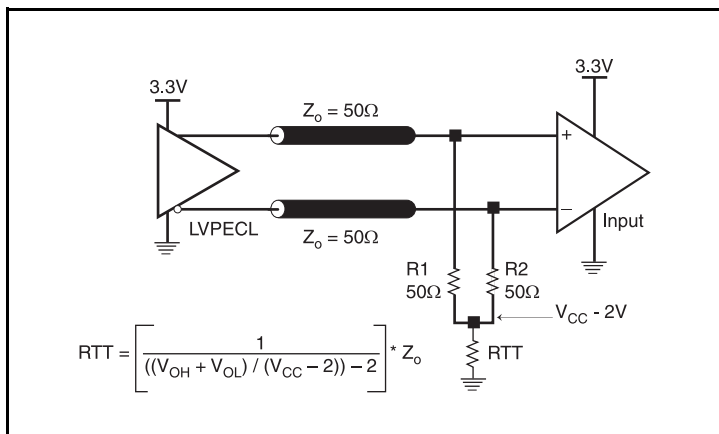

Figure 1A. 3.3V LVPECL Output Termination

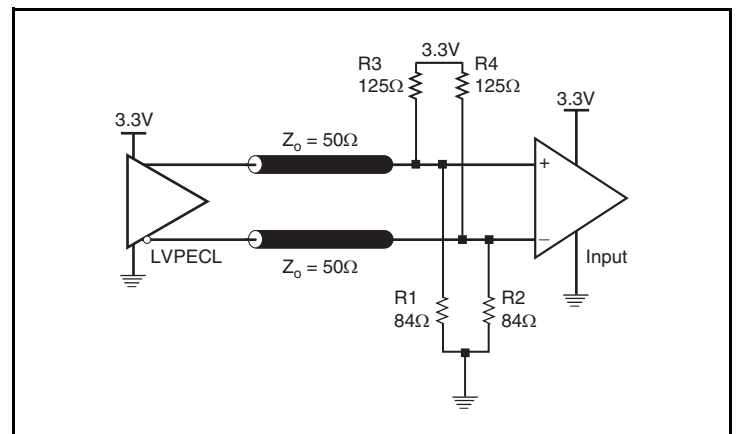

Figure 1B. 3.3V LVPECL Output Termination

### Termination for 2.5V LVPECL Outputs

Figure 2A and Figure 2B show examples of termination for 2.5V LVPECL driver. These terminations are equivalent to terminating  $50\Omega$  to  $V_{CC} - 2V$ . For  $V_{CC} = 2.5V$ , the  $V_{CC} - 2V$  is very close to ground

level. The R3 in Figure 2B can be eliminated and the termination is shown in Figure 2C.

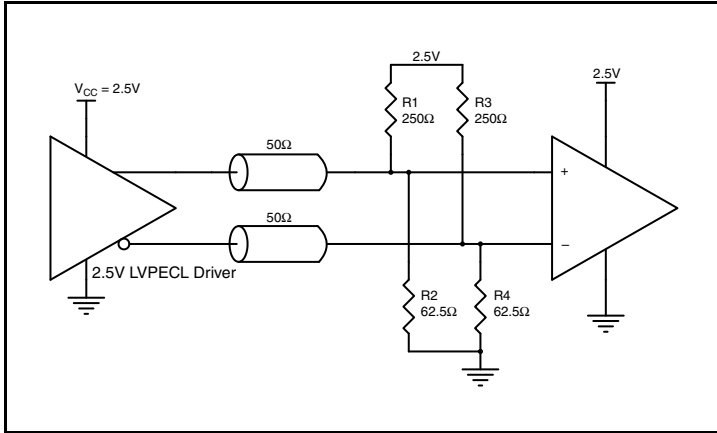

Figure 2A. 2.5V LVPECL Driver Termination Example

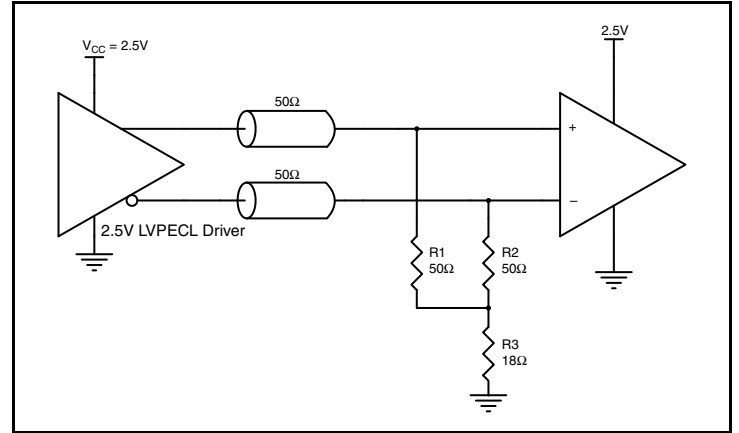

Figure 2B. 2.5V LVPECL Driver Termination Example

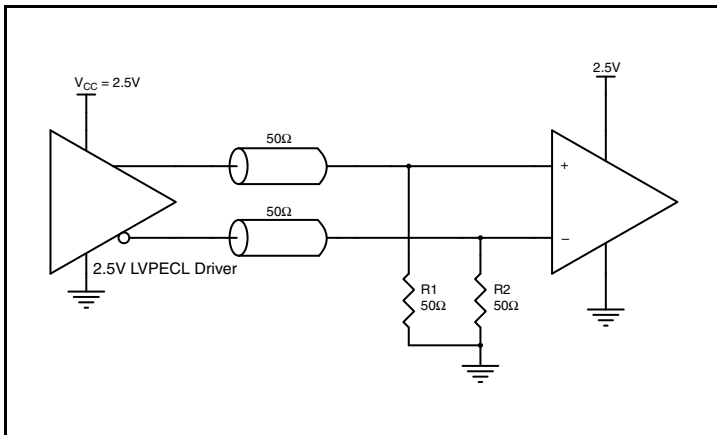

Figure 2C. 2.5V LVPECL Driver Termination Example

## Power Considerations

This section provides information on power dissipation and junction temperature for the ICS8N3DV85. Equations and example calculations are also provided.

### 1. Power Dissipation.

The total power dissipation for the ICS8N3DV85 is the sum of the core power plus the power dissipated due to loading. The following is the power dissipation for  $V_{CC} = 3.3V + 5\% = 3.465V$ , which gives worst case results.

NOTE: Please refer to Section 3 for details on calculating power dissipated due to loading.

- Power (core)<sub>MAX</sub> =  $V_{CC\_MAX} * I_{EE\_MAX} = 3.465V * 160mA = 554.40mW$
- Power (outputs)<sub>MAX</sub> = **30mW/Loaded Output pair**

**Total Power**<sub>MAX</sub> (3.465V, with all outputs switching) =  $554.40mW + 30mW = 584.40mW$

### 2. Junction Temperature.

Junction temperature,  $T_j$ , is the temperature at the junction of the bond wire and bond pad directly affects the reliability of the device. The maximum recommended junction temperature is 125°C. Limiting the internal transistor junction temperature,  $T_j$ , to 125°C ensures that the bond wire and bond pad temperature remains below 125°C.

The equation for  $T_j$  is as follows:  $T_j = \theta_{JA} * Pd\_total + T_A$

$T_j$  = Junction Temperature

$\theta_{JA}$  = Junction-to-Ambient Thermal Resistance

$Pd\_total$  = Total Device Power Dissipation (example calculation is in section 1 above)

$T_A$  = Ambient Temperature

In order to calculate junction temperature, the appropriate junction-to-ambient thermal resistance  $\theta_{JA}$  must be used. Assuming no air flow and a multi-layer board, the appropriate value is 49.4°C/W per Table 6 below.

Therefore,  $T_j$  for an ambient temperature of 85°C with all outputs switching is:

$$85^\circ\text{C} + 0.584\text{W} * 49.4^\circ\text{C/W} = 113.8^\circ\text{C}. \text{ This is below the limit of } 125^\circ\text{C}.$$

This calculation is only an example.  $T_j$  will obviously vary depending on the number of loaded outputs, supply voltage, air flow and the type of board (multi-layer).

**Table 6. Thermal Resistance  $\theta_{JA}$  for 6 Lead Ceramic VFQFN, Forced Convection**

$\theta_{JA}$ by Velocity			
Meters per Second	0	1	2
Multi-Layer PCB, JEDEC Standard Test Boards	49.4°C/W	44.2°C/W	42.1°C/W

### 3. Calculations and Equations.

The purpose of this section is to calculate the power dissipation for the LVPECL output pair.

LVPECL output driver circuit and termination are shown in *Figure 3*.

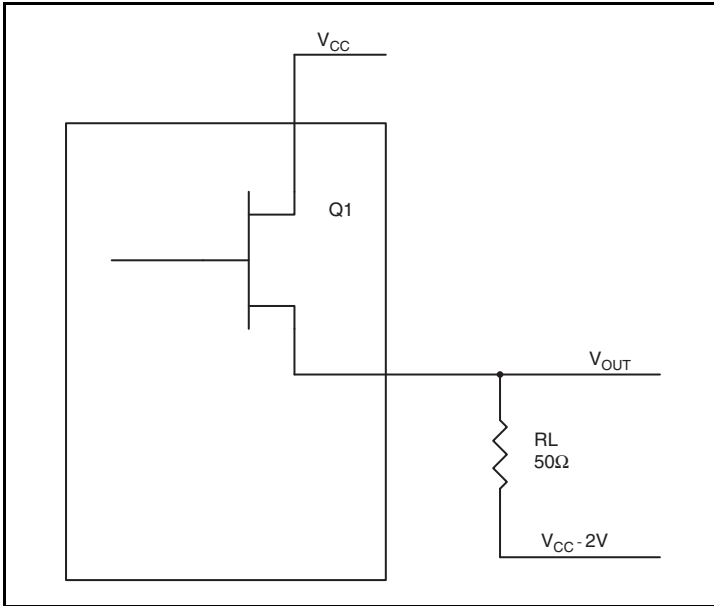

**Figure 3. LVPECL Driver Circuit and Termination**

To calculate power dissipation due to loading, use the following equations which assume a  $50\Omega$  load, and a termination voltage of  $V_{CC} - 2V$ .

- For logic high,  $V_{OUT} = V_{OH\_MAX} = V_{CC\_MAX} - 0.9V$   
( $V_{CC\_MAX} - V_{OH\_MAX}$ ) = **0.9V**
- For logic low,  $V_{OUT} = V_{OL\_MAX} = V_{CC\_MAX} - 1.7V$   
( $V_{CC\_MAX} - V_{OL\_MAX}$ ) = **1.7V**

$Pd\_H$  is power dissipation when the output drives high.

$Pd\_L$  is the power dissipation when the output drives low.

$$Pd\_H = [(V_{OH\_MAX} - (V_{CC\_MAX} - 2V))/R_L] * (V_{CC\_MAX} - V_{OH\_MAX}) = [(2V - (V_{CC\_MAX} - V_{OH\_MAX}))/R_L] * (V_{CC\_MAX} - V_{OH\_MAX}) = [(2V - 0.9V)/50\Omega] * 0.9V = \mathbf{19.8mW}$$

$$Pd\_L = [(V_{OL\_MAX} - (V_{CC\_MAX} - 2V))/R_L] * (V_{CC\_MAX} - V_{OL\_MAX}) = [(2V - (V_{CC\_MAX} - V_{OL\_MAX}))/R_L] * (V_{CC\_MAX} - V_{OL\_MAX}) = [(2V - 1.7V)/50\Omega] * 1.7V = \mathbf{10.2mW}$$

Total Power Dissipation per output pair =  $Pd\_H + Pd\_L = \mathbf{30mW}$

## Reliability Information

**Table 7.  $\theta_{JA}$  vs. Air Flow Table for a 6-lead Ceramic 5mm x 7mm Package**

$\theta_{JA}$ vs. Air Flow			
Meters per Second	<b>0</b>	<b>1</b>	<b>2</b>
Multi-Layer PCB, JEDEC Standard Test Boards	49.4°C/W	44.2°C/W	42.1°C/W

## Transistor Count

The transistor count for IDT8N3DV85 is: 47,511

### Package Outline and Package Dimensions

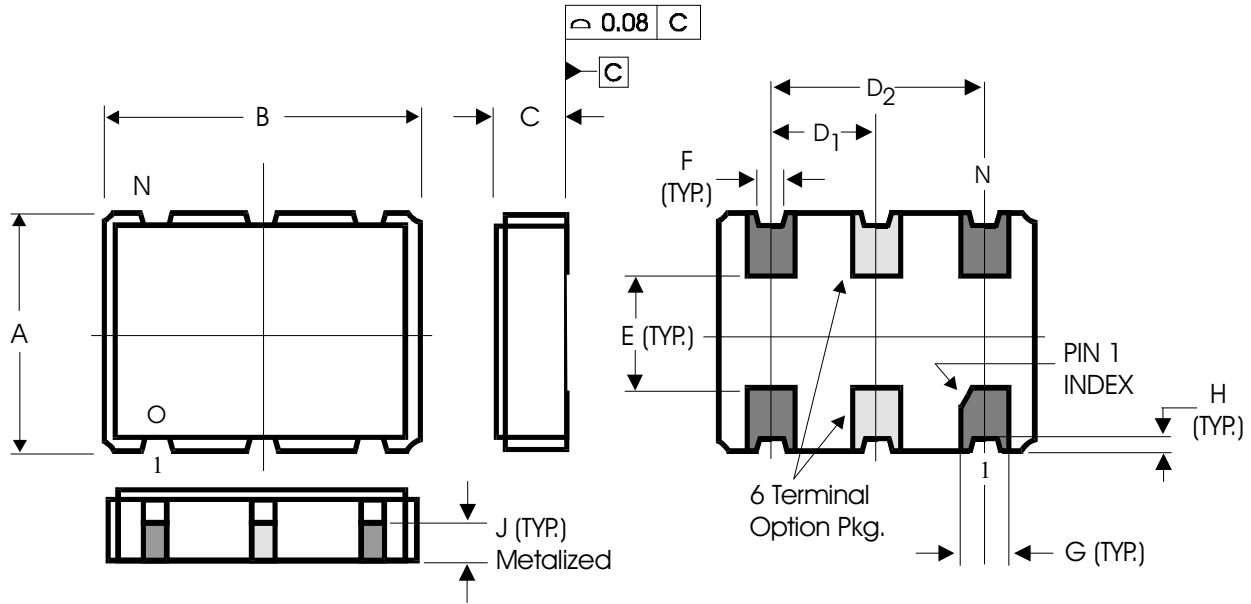

SYMBOL	DIMENSION IN MM		
	MIN.	NOM.	MAX.
A	4.85	5.00	5.15
B	6.85	7.00	7.15
C	1.35	1.50	1.65
D <sub>1</sub>	2.41	2.54	2.67
D <sub>2</sub>	4.95	5.08	5.21
E	2.47	2.6	2.73
F	0.47	0.60	0.73
G	1.27	1.40	1.53
H	-	0.15 Ref.	-
J	-	0.65 Ref.	-



# Ordering Information for FemtoClock® NG Ceramic-Package XO and VCXO Products

The programmable VCXO and XO devices support a variety of device options such as the output type, number of default frequencies, internal crystal frequency, power supply voltage, ambient temperature range and the frequency accuracy. The device options, default frequencies and default VCXO pull range must be specified at the time of order and are programmed by IDT before the shipment. The table below specifies the available order codes, including the device options and default frequency configurations. Example part number: the order code 8N3QV01FG-0001CDI specifies a programmable, quad default-frequency VCXO with a voltage supply of 2.5V, a LVPECL output, a ±50 ppm crystal frequency accuracy,

contains a 114.285MHz internal crystal as frequency source, industrial temperature range, a lead-free (6/6 RoHS) 6-lead ceramic 5mm x 7mm x 1.55mm package and is factory-programmed to the default frequencies of 100MHz, 122.88MHz, 125MHz and 156.25MHz and to the VCXO pull range of minimum ±100 ppm.

Other default frequencies and order codes are available from IDT on request. For more information on available default frequencies, see the *FemtoClock N Ceramic-Package XO and VCXO Ordering Product Information* document.

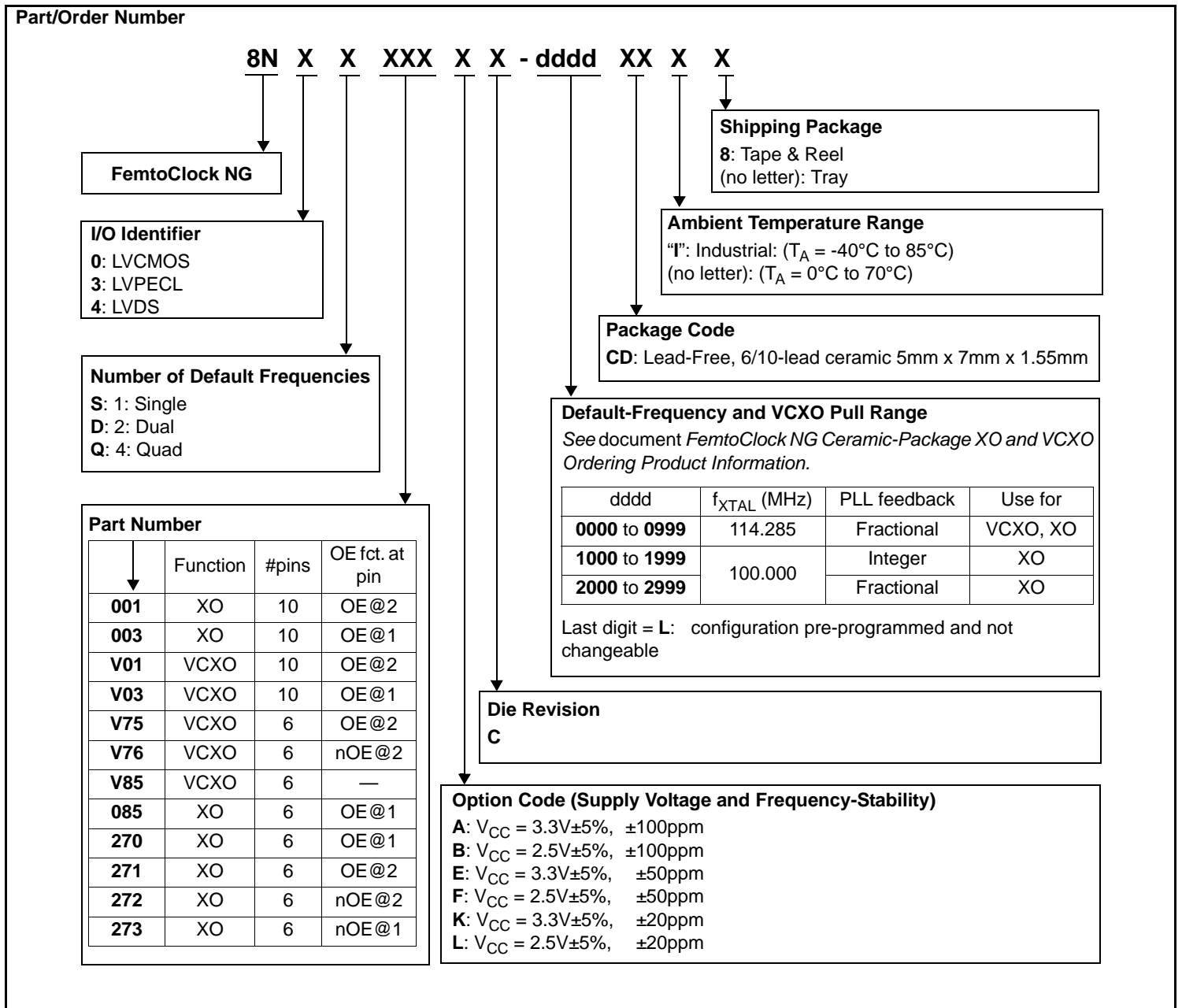

**Table 8. Device Marking**

Marking	Industrial Temperature Range ( $T_A = -40^{\circ}\text{C}$ to $85^{\circ}\text{C}$ )	Commercial Temperature Range ( $T_A = 0^{\circ}\text{C}$ to $70^{\circ}\text{C}$ )
		IDT8N3DV85yC- <b>ddddCDI</b>
<b>y</b> = Option Code, <b>dddd</b> =Default-Frequency and VCXO Pull Range		

## Revision History Sheet

Rev	Table	Page	Description of Change	Date
A	T6	6	Absolute Maximum Rating - corrected Package Thermal Impedance.	4/27/12
		12	Added RMS Period Jitter diagram	
		14	Power Considerations - corrected Thermal Resistance table, updated Junction Temperature calculation.	
		13	Corrected Air Flow table.	
A	AMR	6	Absolute Maximum Rating; $V_{CC} = 3.71V$	2/5/13
A	T5A	7	AC Characteristic Tables - RMS Phase Jitter changed test conditions from: $500MHz \leq f_{OUT}$ to $500MHz < f_{OUT}$ ; $125MHz \leq f_{OUT}$ to $125MHz < f_{OUT}$ .	10/30/13

## We've Got Your Timing Solution



6024 Silver Creek Valley Road  
San Jose, California 95138

**Sales**  
800-345-7015 (inside USA)  
+408-284-8200 (outside USA)  
Fax: 408-284-2775  
[www.IDT.com/go/contactIDT](http://www.IDT.com/go/contactIDT)

**Technical Support**  
[netcom@idt.com](mailto:netcom@idt.com)  
+480-763-2056

DISCLAIMER Integrated Device Technology, Inc. (IDT) and its subsidiaries reserve the right to modify the products and/or specifications described herein at any time and at IDT's sole discretion. All information in this document, including descriptions of product features and performance, is subject to change without notice. Performance specifications and the operating parameters of the described products are determined in the independent state and are not guaranteed to perform the same way when installed in customer products. The information contained herein is provided without representation or warranty of any kind, whether express or implied, including, but not limited to, the suitability of IDT's products for any particular purpose, an implied warranty of merchantability, or non-infringement of the intellectual property rights of others. This document is presented only as a guide and does not convey any license under intellectual property rights of IDT or any third parties.

IDT's products are not intended for use in applications involving extreme environmental conditions or in life support systems or similar devices where the failure or malfunction of an IDT product can be reasonably expected to significantly affect the health or safety of users. Anyone using an IDT product in such a manner does so at their own risk, absent an express, written agreement by IDT.

Integrated Device Technology, IDT and the IDT logo are registered trademarks of IDT. Other trademarks and service marks used herein, including protected names, logos and designs, are the property of IDT or their respective third party owners.

Copyright 2013. All rights reserved.



Компания «ЭлектроПласт» предлагает заключение долгосрочных отношений при поставках импортных электронных компонентов на взаимовыгодных условиях!

Наши преимущества:

- Оперативные поставки широкого спектра электронных компонентов отечественного и импортного производства напрямую от производителей и с крупнейших мировых складов;
- Поставка более 17-ти миллионов наименований электронных компонентов;
- Поставка сложных, дефицитных, либо снятых с производства позиций;
- Оперативные сроки поставки под заказ (от 5 рабочих дней);
- Экспресс доставка в любую точку России;
- Техническая поддержка проекта, помощь в подборе аналогов, поставка прототипов;
- Система менеджмента качества сертифицирована по Международному стандарту ISO 9001;
- Лицензия ФСБ на осуществление работ с использованием сведений, составляющих государственную тайну;
- Поставка специализированных компонентов (Xilinx, Altera, Analog Devices, Intersil, Interpoint, Microsemi, Aeroflex, Peregrine, Syfer, Eurofarad, Texas Instrument, Miteq, Cobham, E2V, MA-COM, Hittite, Mini-Circuits, General Dynamics и др.);

Помимо этого, одним из направлений компании «ЭлектроПласт» является направление «Источники питания». Мы предлагаем Вам помощь Конструкторского отдела:

- Подбор оптимального решения, техническое обоснование при выборе компонента;
- Подбор аналогов;
- Консультации по применению компонента;
- Поставка образцов и прототипов;
- Техническая поддержка проекта;
- Защита от снятия компонента с производства.



#### Как с нами связаться

**Телефон:** 8 (812) 309 58 32 (многоканальный)

**Факс:** 8 (812) 320-02-42

**Электронная почта:** [org@eplast1.ru](mailto:org@eplast1.ru)

**Адрес:** 198099, г. Санкт-Петербург, ул. Калинина, дом 2, корпус 4, литера А.