

Features

- Low Voltage Operation: 2.5 V
- Low Harmonics: < -66 dBc at +34 dBm & 1 GHz
- Low Insertion Loss: 0.7 dB at 1 GHz
- High Isolation: 25 dB at 2 GHz
- 0.5 micron GaAs pHEMT Process
- Low Profile, Lead-Free 3 mm PQFN Package
- Halogen-Free "Green" Mold Compound
- RoHS* Compliant and 260°C Re-flow Compatible

Description

M/A-COM's MASW-007813 is a GaAs pHEMT MMIC single pole four throw (SP4T) high power switch in a low cost, low profile, lead-free 3 mm PQFN 16-lead package. The MASW-007813 is ideally suited for applications where high power, low control voltage, low insertion loss, high isolation, small size and low cost are required.

Typical applications are for GSM and DCS handset systems that connect separate transmit and receive functions to a common antenna, as well as CDMA handset and other related applications. The MASW-007813 can be used in all systems operating up to 3 GHz requiring high power at low control voltage.

The MASW-007813 is fabricated using a 0.5 micron gate length GaAs pHEMT process. The process features full passivation for performance and reliability.

Ordering Information ^{1,2}

Part Number	Package
MASW-007813-TR3000	3000 piece reel
MASW-007813-001SMB	Sample Board

1. Reference Application Note M513 for reel size information.
2. All sample boards include 5 loose parts.

* Restrictions on Hazardous Substances, European Union Directive 2002/95/EC.

Functional Schematic

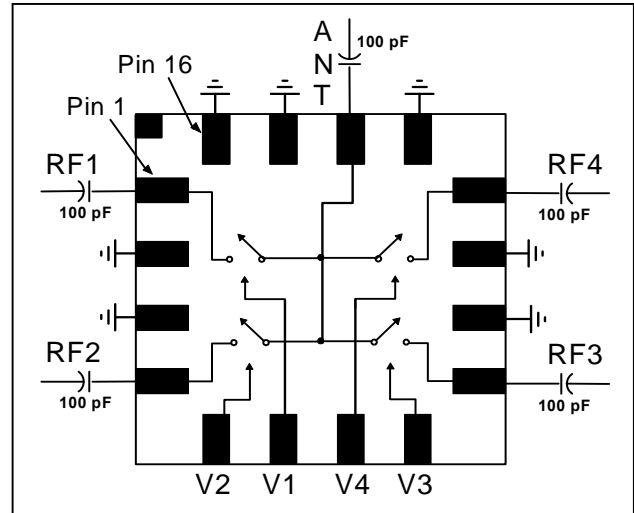

Pin Configuration

Pin No.	Pin Name	Description
1	RF1	RF Port 1
2	GND	RF Ground
3	GND	RF Ground
4	RF2	RF Port 2
5	V2	Control 2
6	V1	Control 1
7	V4	Control 4
8	V3	Control 3
9	RF3	RF Port 3
10	GND	RF Ground
11	GND	RF Ground
12	RF4	RF Port 4
13	GND	RF Ground
14	ANT	Antenna Port
15	GND	RF Ground
16	GND	RF Ground
17	GND (paddle) ³	RF Ground

3. The exposed pad centered on the package bottom must be connected to RF and DC ground.

GaAs SP4T High Power Switch DC - 3 GHz

Rev. V2

Electrical Specifications: $T_A = 25^\circ\text{C}$, $V_C = 0\text{ V} / 2.75\text{ V}$, $P_{IN} = 34\text{ dBm}$, $Z_0 = 50\ \Omega$ ⁴

Parameter	Test Conditions	Units	Min.	Typ.	Max.
Insertion Loss ⁵	DC - 1 GHz	dB	—	0.7	0.85
	1 - 2 GHz		—	0.8	—
	2 - 3 GHz		—	1.0	—
Isolation	DC - 1 GHz	dB	25	33	—
	1 - 2 GHz		—	27	—
	2 - 3 GHz		—	23	—
Return Loss	DC - 3 GHz	dB	—	20	—
P0.1dB	1 GHz	dBm	—	38	—
IP2	Two Tone, +26 dBm/Tone, 5 MHz spacing, > 50 MHz	dBm	—	96	—
IP3	Two Tone, +26 dBm/Tone, 5 MHz spacing, > 50 MHz	dBm	—	58	—
2nd Harmonic	1 GHz, Pin = +34 dBm	dBc	—	-76	-68
3rd Harmonic	1 GHz, Pin = +34 dBm	dBc	—	-68	-66
Trise, Tfall	10% to 90% RF, 90% to 10% RF	ns	—	40	—
Ton, Toff	50% Control to 90% RF, 50% Control to 10% RF	ns	—	110	—
Transients		mV	—	40	—
Control Current	$V_C = 2.75\text{ V}$	μA	—	20	80

4. For positive voltage control, external DC blocking capacitors are required on all RF ports.

5. Insertion loss can be optimized by varying the DC blocking capacitor value, e.g. 1000 pF for 100 MHz - 1 GHz, 39 pF for 0.5 GHz - 3 GHz.

Truth Table^{6,7}

V1	V2	V3	V4	ANT - RF1	ANT - RF2	ANT - RF3	ANT - RF4
1	0	0	0	On	Off	Off	Off
0	1	0	0	Off	On	Off	Off
0	0	1	0	Off	Off	On	Off
0	0	0	1	Off	Off	Off	On

6. Differential voltage, V (state 1) - V (state 0), must be +2.5 V minimum and must not exceed 8.5 V.

7. 0 = -8.5 V to 0 V, 1 = -6 V to 8.5 V

Absolute Maximum Ratings⁸

Parameter	Absolute Maximum
Max Input Power (0.5 - 3 GHz, 2.75 V Control)	+38 dBm
Operating Voltage	+8.5 volts
Operating Temperature	-40°C to +85°C
Storage Temperature	-65°C to +150°C

8. Exceeding any one or combination of these limits may cause permanent damage to this device.

Typical Performance Curves

Insertion Loss

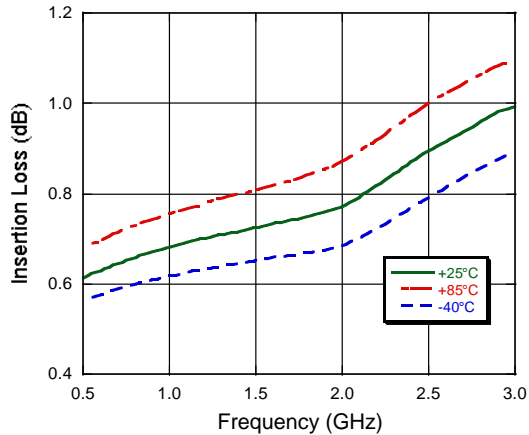

Isolation

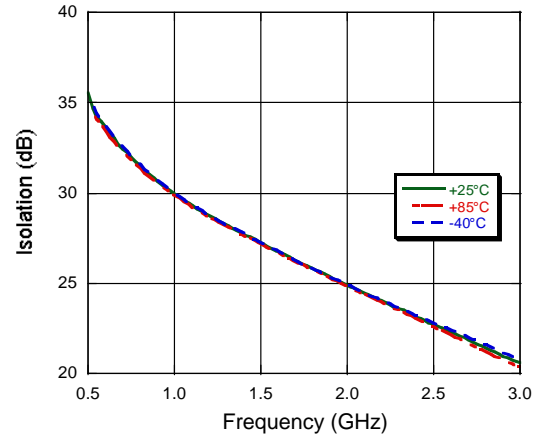

Return Loss

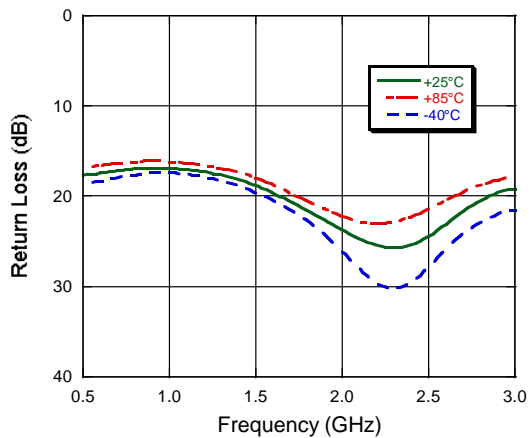

Harmonics vs. Control Voltage, 1 GHz

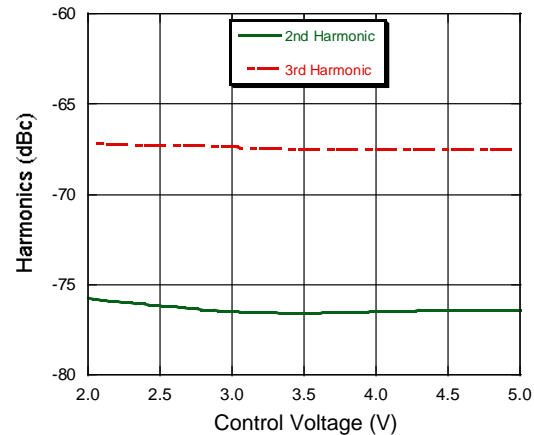

Low Profile, Lead-Free 3 mm 16-lead PQFN †

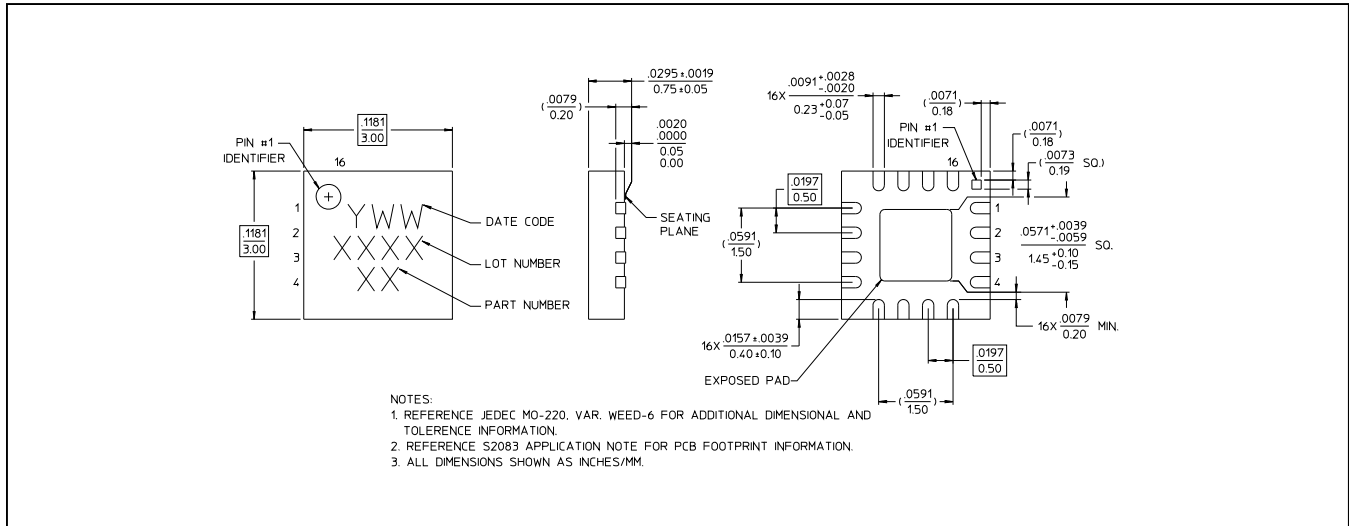

† Reference Application Note M538 for lead-free solder reflow recommendations.
Meets JEDEC moisture sensitivity level 1 requirements.
Plating is 100% matte tin over copper.

Qualification

Qualified to M/A-COM specification REL-201, Process Flow -2.

Handling Procedures

The following precautions should be observed to avoid damage:

Static Sensitivity

Gallium Arsenide Integrated Circuits are sensitive to electrostatic discharge (ESD) and can be damaged by static electricity. Proper ESD control techniques should be used when handling these devices.



Компания «ЭлектроПласт» предлагает заключение долгосрочных отношений при поставках импортных электронных компонентов на взаимовыгодных условиях!

Наши преимущества:

- Оперативные поставки широкого спектра электронных компонентов отечественного и импортного производства напрямую от производителей и с крупнейших мировых складов;
- Поставка более 17-ти миллионов наименований электронных компонентов;
- Поставка сложных, дефицитных, либо снятых с производства позиций;
- Оперативные сроки поставки под заказ (от 5 рабочих дней);
- Экспресс доставка в любую точку России;
- Техническая поддержка проекта, помощь в подборе аналогов, поставка прототипов;
- Система менеджмента качества сертифицирована по Международному стандарту ISO 9001;
- Лицензия ФСБ на осуществление работ с использованием сведений, составляющих государственную тайну;
- Поставка специализированных компонентов (Xilinx, Altera, Analog Devices, Intersil, Interpoint, Microsemi, Aeroflex, Peregrine, Syfer, Eurofarad, Texas Instrument, Miteq, Cobham, E2V, MA-COM, Hittite, Mini-Circuits, General Dynamics и др.);

Помимо этого, одним из направлений компании «ЭлектроПласт» является направление «Источники питания». Мы предлагаем Вам помощь Конструкторского отдела:

- Подбор оптимального решения, техническое обоснование при выборе компонента;
- Подбор аналогов;
- Консультации по применению компонента;
- Поставка образцов и прототипов;
- Техническая поддержка проекта;
- Защита от снятия компонента с производства.



Как с нами связаться

Телефон: 8 (812) 309 58 32 (многоканальный)

Факс: 8 (812) 320-02-42

Электронная почта: org@eplast1.ru

Адрес: 198099, г. Санкт-Петербург, ул. Калинина, дом 2, корпус 4, литера А.