

FEATURES

- 50ps output-to-output skew
- Synchronous enable/disable
- Multiplexed clock input
- 75K Ω internal input pull-down resistors
- Available in 16-pin SOIC package

**Precision Edge[®]****DESCRIPTION**

The SY10/100EL15 are low skew 1:4 clock distribution chips designed explicitly for low skew clock distribution applications. The device can be driven by either a differential or single-ended ECL or, if positive power supplies are used, PECL input signal. If a single-ended input is to be used the VBB output should be connected to the CLK input and bypassed to VCC via a 0.01 μ F capacitor. The VBB output is designed to act as the switching reference for the input of the EL15 under single-ended input conditions, as a result this pin can only source/sink up to 0.5mA of current.

The EL15 features a multiplexed clock input to allow for the distribution of a lower speed scan or test clock along with the high speed system clock. When LOW (or left open and pulled LOW by the input pull-down resistor) the SEL pin will select the differential clock input.

The common enable (EN) is synchronous so that the outputs will only be enabled/disabled when they are already in the LOW state. This avoids any chance of generating a runt clock pulse when the device is enabled/disabled as can happen with an asynchronous control. The internal flip flop is clocked on the falling edge of the input clock, therefore all associated specification limits are referenced to the negative edge of the clock input.

PACKAGE/ORDERING INFORMATION

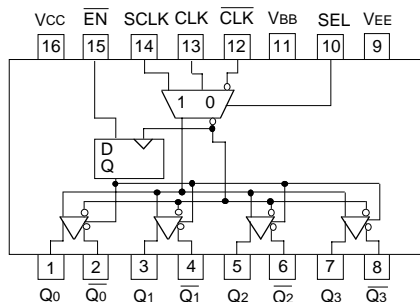

16-Pin Narrow SOIC (Z8-1)

Ordering Information⁽¹⁾

Part Number	Package Type	Operating Range	Package Marking	Lead Finish
SY10EL15ZC	Z16-2	Commercial	SY10EL15ZC	Sn-Pb
SY10EL15ZCTR ⁽²⁾	Z16-2	Commercial	SY10EL15ZC	Sn-Pb
SY100EL15ZC	Z16-2	Commercial	SY100EL15ZC	Sn-Pb
SY100EL15ZCTR ⁽²⁾	Z16-2	Commercial	SY100EL15ZC	Sn-Pb
SY10EL15ZI	Z16-2	Industrial	SY10EL15ZI	Sn-Pb
SY10EL15ZITR ⁽²⁾	Z16-2	Industrial	SY10EL15ZI	Sn-Pb
SY100EL15ZI	Z16-2	Industrial	SY100EL15ZI	Sn-Pb
SY100EL15ZITR ⁽²⁾	Z16-2	Industrial	SY100EL15ZI	Sn-Pb
SY10EL15ZG ⁽³⁾	Z16-2	Industrial	SY10EL15ZG with Pb-Free bar-line indicator	Pb-Free NiPdAu
SY10EL15ZGTR ^(2, 3)	Z16-2	Industrial	SY10EL15ZG with Pb-Free bar-line indicator	Pb-Free NiPdAu
SY100EL15ZG ⁽³⁾	Z16-2	Industrial	SY100EL15ZG with Pb-Free bar-line indicator	Pb-Free NiPdAu
SY100EL15ZGTR ^(2, 3)	Z16-2	Industrial	SY100EL15ZG with Pb-Free bar-line indicator	Pb-Free NiPdAu

Notes:

1. Contact factory for die availability. Dice are guaranteed at T_A = 25°C, DC Electricals only.
2. Tape and Reel.
3. Pb-Free package is recommended for new designs.

PIN NAMES

Pin	Function
CLK	Differential Clock Inputs
SCLK	Synchronous Clock Input
EN	Synchronous Enable
SEL	Clock Select Input
VBB	Reference Output
Q0-3	Differential Clock Outputs

TRUTH TABLE

CLK	SCLK	SEL	EN	Q
L	X	L	L	L
H	X	L	L	H
X	L	H	L	L
X	H	H	L	H
X	X	X	H	L*

* On next negative transition of CLK or SCLK

ABSOLUTE MAXIMUM RATINGS⁽¹⁾

Symbol	Rating	Value	Unit
VEE	Power Supply (V _{CC} = 0V)	-8.0 to 0	VDC
V _I	Input Voltage (V _{CC} = 0V)	0 to -6.0	VDC
I _{OUT}	Output Current -Continuous -Surge	50 100	mA
T _{LEAD}	Lead Temperature Range (soldering, 20sec.)	+260	°C
T _A	Operating Temperature Range	-40 to +85	°C
VEE	Operating Range ^{(1),(2)}	-5.7 to -4.2	V

NOTES:

- Absolute maximum rating, beyond which, device life may be impaired, unless otherwise specified on an individual data sheet.
- Parametric values specified at:

100EL15 Series:	-4.2V to -5.5V.
10EL15 Series	-4.75V to -5.5V.

10EL DC ELECTRICAL CHARACTERISTICSV_{EE} = V_{EE} (Min.) to V_{EE} (Max.); V_{CC} = GND⁽¹⁾

Symbol	Parameter	T _A = -40°C		T _A = 0°C		T _A = +25°C			T _A = +85°C		Unit
		Min.	Max.	Min.	Max.	Min.	Typ.	Max.	Min.	Max.	
V _{OH}	Output HIGH Voltage	-1080	-890	-1020	-840	-980	—	-810	-910	-720	mV
V _{OL}	Output LOW Voltage	-1950	-1650	-1950	-1630	-1950	—	-1630	-1950	-1595	mV
V _{IH}	Input HIGH Voltage	-1230	-890	-1170	-840	-1130	—	-810	-1060	-720	mV
V _{IL}	Input LOW Voltage	-1950	-1500	-1950	-1480	-1950	—	-1480	-1950	-1445	mV
I _{IH}	Input High Current	—	150	—	150	—	—	150	—	150	μA
I _{IL}	Input LOW Current	0.5	—	0.5	—	0.5	—	—	0.5	—	μA
I _{EE}	Power Supply Current	—	35	—	35	—	25	35	—	38	mA
V _{BB}	Output Reference Voltage	-1.38	-1.26	-1.38	-1.26	-1.38	—	-1.26	-1.38	-1.26	V

NOTE:

- 10EL circuits are designed to meet the DC specifications shown in the table after thermal equilibrium has been established. The circuit is in a test socket or mounted on a printed circuit board and transverse airflow greater than 500lfpm is maintained. Outputs are terminated through a 50Ω resistor to -2.0V except where otherwise specified on the individual data sheets.

100EL DC ELECTRICAL CHARACTERISTICS

$V_{EE} = V_{EE} (\text{Min.})$ to $V_{EE} (\text{Max.})$; $V_{CC} = \text{GND}^{(1)}$

Symbol	Parameter	$T_A = -40^\circ\text{C}$		$T_A = 0^\circ\text{C}$		$T_A = +25^\circ\text{C}$			$T_A = +85^\circ\text{C}$		Unit
		Min.	Max.	Min.	Max.	Min.	Typ.	Max.	Min.	Max.	
V_{OH}	Output HIGH Voltage ⁽²⁾	-1085	-880	-1025	-880	-1025	-955	-880	-1025	-880	mV
V_{OL}	Output LOW Voltage ⁽²⁾	-1830	-1555	-1810	-1620	-1810	-1705	-1620	-1810	-1620	mV
V_{OHA}	Output HIGH Voltage ⁽³⁾	-1095	—	-1035	—	-1035	—	—	-1035	—	mV
V_{OLA}	Output LOW Voltage ⁽³⁾	—	-1555	—	-1610	—	—	-1610	—	-1610	mV
V_{IH}	Input HIGH Voltage	-1165	-880	-1165	-880	-1165	—	-880	-1165	-880	mV
V_{IL}	Input LOW Voltage	-1810	-1475	-1810	-1475	-1810	—	-1475	-1810	-1475	mV
I_{IH}	Input High Current	—	150	—	150	—	—	150	—	150	μA
I_{IL}	Input LOW Current ⁽⁴⁾	0.5	—	0.5	—	0.5	—	—	0.5	—	μA
I_{EE}	Power Supply Current	—	35	—	35	—	25	35	—	38	mA
V_{BB}	Output Reference Voltage	-1.38	-1.26	-1.38	-1.26	-1.38	—	-1.26	-1.38	-1.26	V

NOTES:

1. This table replaces the three traditionally seen in ECL 100K data books. The same DC parameter values at $V_{EE} = -4.5\text{V}$ now apply across the full V_{EE} range of -4.2V to -5.5V . Outputs are terminated through a 50Ω resistor to -2.0V except where otherwise specified on the individual data sheets.
2. $V_{IN} = V_{IH}(\text{Max})$ or $V_{IL}(\text{Min})$.
3. $V_{IN} = V_{IH}(\text{Min})$ or $V_{IL}(\text{Max})$.
4. $V_{IN} = V_{IL}(\text{Max})$.

AC ELECTRICAL CHARACTERISTICS

$V_{EE} = V_{EE} (\text{Min.})$ to $V_{EE} (\text{Max.})$; $V_{CC} = \text{GND}$

Symbol	Parameter	$T_A = -40^\circ\text{C}$		$T_A = 0^\circ\text{C}$		$T_A = +25^\circ\text{C}$			$T_A = +85^\circ\text{C}$		Unit
		Min.	Max.	Min.	Max.	Min.	Typ.	Max.	Min.	Max.	
t_{PD}	Propagation Delay CLK to Q (Diff) CLK to Q (SE) SCLK to Q	460 410 410	660 710 710	470 420 420	670 720 720	470 420 420	— — —	670 720 720	500 450 470	700 750 750	ps
t_{skew}	Part-to-Part Skew ⁽¹⁾ Within-Device Skew	— —	200 50	— —	200 50	— —	— —	200 50	— —	200 50	ps
t_S	Setup Time \overline{EN}	150	—	150	—	150	—	—	150	—	ps
t_H	Hold Time \overline{EN}	400	—	400	—	400	—	—	400	—	ps
V_{PP}	Minimum Input Swing CLK	250	—	250	—	250	—	—	250	—	mV
V_{CMR}	Common Mode Range CLK	-2.0	-0.4	-2.0	-0.4	-2.0	—	-0.4	-2.0	-0.4	V
t_r t_f	Output Rise/Fall Times Q (20% – 80%)	—	—	325	575	325	—	575	325	575	ps

NOTE:

1. Skews are specified for identical LOW-to-HIGH or HIGH-to-LOW transitions.

16-PIN SOIC .150" WIDE (Z16-2)

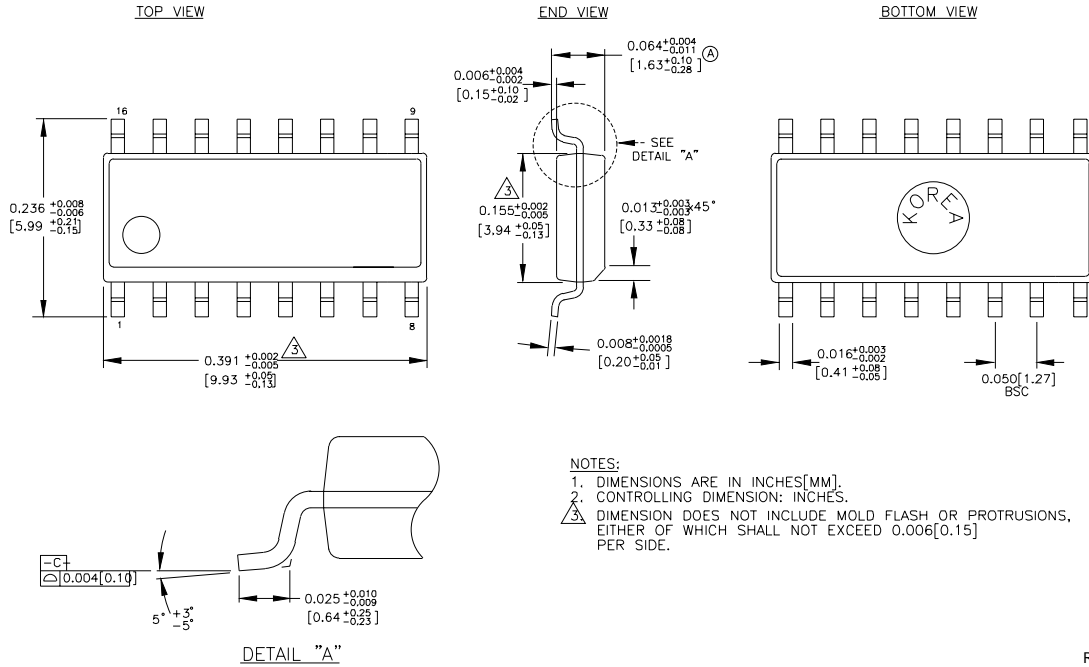

Rev. 02

MICREL, INC. 2180 FORTUNE DRIVE SAN JOSE, CA 95131 USA

TEL + 1 (408) 944-0800 FAX + 1 (408) 474-1000 WEB <http://www.micrel.com>

The information furnished by Micrel in this datasheet is believed to be accurate and reliable. However, no responsibility is assumed by Micrel for its use. Micrel reserves the right to change circuitry and specifications at any time without notification to the customer.

Micrel Products are not designed or authorized for use as components in life support appliances, devices or systems where malfunction of a product can reasonably be expected to result in personal injury. Life support devices or systems are devices or systems that (a) are intended for surgical implant into the body or (b) support or sustain life, and whose failure to perform can be reasonably expected to result in a significant injury to the user. A Purchaser's use or sale of Micrel Products for use in life support appliances, devices or systems is at Purchaser's own risk and Purchaser agrees to fully indemnify Micrel for any damages resulting from such use or sale.

© 2006 Micrel, Incorporated.



Компания «ЭлектроПласт» предлагает заключение долгосрочных отношений при поставках импортных электронных компонентов на взаимовыгодных условиях!

Наши преимущества:

- Оперативные поставки широкого спектра электронных компонентов отечественного и импортного производства напрямую от производителей и с крупнейших мировых складов;
- Поставка более 17-ти миллионов наименований электронных компонентов;
- Поставка сложных, дефицитных, либо снятых с производства позиций;
- Оперативные сроки поставки под заказ (от 5 рабочих дней);
- Экспресс доставка в любую точку России;
- Техническая поддержка проекта, помощь в подборе аналогов, поставка прототипов;
- Система менеджмента качества сертифицирована по Международному стандарту ISO 9001;
- Лицензия ФСБ на осуществление работ с использованием сведений, составляющих государственную тайну;
- Поставка специализированных компонентов (Xilinx, Altera, Analog Devices, Intersil, Interpoint, Microsemi, Aeroflex, Peregrine, Syfer, Eurofarad, Texas Instrument, Miteq, Cobham, E2V, MA-COM, Hittite, Mini-Circuits, General Dynamics и др.);

Помимо этого, одним из направлений компании «ЭлектроПласт» является направление «Источники питания». Мы предлагаем Вам помощь Конструкторского отдела:

- Подбор оптимального решения, техническое обоснование при выборе компонента;
- Подбор аналогов;
- Консультации по применению компонента;
- Поставка образцов и прототипов;
- Техническая поддержка проекта;
- Защита от снятия компонента с производства.



Как с нами связаться

Телефон: 8 (812) 309 58 32 (многоканальный)

Факс: 8 (812) 320-02-42

Электронная почта: org@eplast1.ru

Адрес: 198099, г. Санкт-Петербург, ул. Калинина, дом 2, корпус 4, литера А.