





Messrs.					
Product Specification	Model	NMTC-S0802XRYHS-13	Rev. No.	Issued Date.	Page.
			A	August. 16, 17	1 / 29

LIQUID CRYSTAL DISPLAY MODULE
MODEL: NMTC-S0802XRYHS-13
Customer's No.: None.

Acceptance

Microtips Technology Inc.
12F. No.31 Lane 169, Kang Ning St.,
His-Chih, Taipei Hsien, Taiwan, R.O.C.
FAX: 886-2-26958625

Approved and Checked by

Approved by	Checked by		Made by
			



Microtips Technology Inc.

Messrs.					
Product Specification	Model	NMTC-S0802XRYHS-13	Rev. No.	Issued Date.	Page.
			<i>A</i>	<i>August. 16, 17</i>	<i>2 / 29</i>

Revise Records

Rev.	Date	Contents	Written	Approved
A.	2017/08/16	See Note 1.	Jill Hsu	Danny Lien

Special Notes

Note 1.	The LCD module is compliant with RoHS.
Note 2.	
Note 3.	
Note 4.	
Note 5.	



Messrs.					
Product Specification	Model	NMTC-S0802XRYHS-13	Rev. No.	Issued Date.	Page.
			<i>A</i>	<i>August. 16, 17</i>	<i>3 / 29</i>

CONTENTS

ITEM	PAGE
FEATURES	5.
GENERAL SPECIFICATION	6.
ABSOLUTE MAXIMUM RATING	6.
ELECTRICAL CHARACTERISTICS	7.
OPTICAL CHARACTERISTICS	7.
MECHANICAL SPECIFICATION	8.
INTERFACE PIN ASSIGNMENT	9.
BLOCK DIAGRAM	12.
POWER SUPPLY DIAGRAM	12.
TIMING CHARACTERISTICS	13.
READ / WRITE TIMING CHART	14.
COMMANDS	15.
COMMANDS DESCRIPTION	16.
DD RAM ADDRESSING	20.
CG RAM MAPPING	22.



Messrs.					
Product Specification	Model	NMTC-S0802XRYHS-13	Rev. No.	Issued Date.	Page.
			<i>A</i>	<i>August. 16, 17</i>	<i>4 / 29</i>

ITEM	PAGE
CHARACTER FONT TABLE	23.
RELIABILITY TEST	24.
APPEARANCE CHECK	24.
HANDLING PRECAUTIONS	25.
LCD PRODUCT QUALITY STANDARD	26.
WARRANTY	28.
DIMENSIONAL OUTLINES	29.



Messrs.					
Product Specification	Model	NMTC-S0802XRYHS-13	Rev. No.	Issued Date.	Page.
			A	August. 16, 17	5 / 29

FEATURES of
LIQUID CRYSTAL DISPLAY MODULE
MODEL NO.: NMTC-S0802XRYHS-13

Character Type Dot Matrix LCD Module

Easy interface of 4 – bit or 8 – bit

Display character pattern: 5 × 7 font with cursor (208 kinds)

The special character pattern can be programmable by Character Generator RAM directly.

A customer character pattern can be programmable by mask option.

Automatically power on reset.

Internal Memory:

- Character Generator ROM (CGROM): 10,080 bits (204 characters × 5 × 8 dot)
- Character Generator RAM (CGRAM): 64 × 8 bits (8 characters × 5 × 8 dot)

Low power operation:

- Power supply voltage range: 2.7 ~ 5.5 V (V_{DD})
- LCD drive voltage range: 3.0 ~ 13.0 V (V_{DD} – V_O)

Low power consumption

CMOS process

Duty – cycle: 1/16

View Direction	<input checked="" type="checkbox"/> 6 O'clock		<input type="checkbox"/> 12 O'clock		
LCD Type	<input type="checkbox"/> FSTN Positive		<input type="checkbox"/> FSTN Negative		
	<input type="checkbox"/> STN Gray	<input checked="" type="checkbox"/> STN Yellow Green		<input type="checkbox"/> STN Blue	
Rear Polarizer	<input checked="" type="checkbox"/> Reflective		<input type="checkbox"/> Transflective		<input type="checkbox"/> Transmissive
Backlight Type	<input type="checkbox"/> LED	<input type="checkbox"/> EL	<input type="checkbox"/> Internal Power		<input type="checkbox"/> 5V input
		<input type="checkbox"/> CCFL	<input type="checkbox"/> External Power		<input type="checkbox"/> 12V input
Backlight Color	<input type="checkbox"/> White	<input type="checkbox"/> Amber	<input type="checkbox"/> Blue Green	<input type="checkbox"/> Yellow Green	<input type="checkbox"/> Other
Temperature Range	<input type="checkbox"/> Normal		<input checked="" type="checkbox"/> Wide		<input type="checkbox"/> Super Wide
CCFL Inverter	<input type="checkbox"/> Build – in		<input checked="" type="checkbox"/> Not Build – in		
EL Driver IC	<input type="checkbox"/> Build – in		<input checked="" type="checkbox"/> Not Build – in		
Touch Screen	<input type="checkbox"/> With		<input checked="" type="checkbox"/> Without		

TO BE VERY CAREFUL !

The LCD driver ICs are made of CMOS process, which is very easy to be damaged by static charge, make sure the user is grounded when handling the LCM.



Messrs.					
Product Specification	Model	NMTC-S0802XRYHS-13	Rev. No.	Issued Date.	Page.
			A	August. 16, 17	6 / 29

GENERAL SPECIFICATION

Item	Content
Display Resolution	8 Characters × 2 lines
Dimensional Outline (mm)	58.0 (W) × 32.0 (H) × 18.0 max (D)
Display mode	Reflective / Positive Type
Circuit	Controller IC, Segment – driver IC
Interface	Data (DB0~DB7), RS, R/W, E

ABSOLUTE MAXIMUM RATING

(1) Electrical Absolute Ratings

Item	Symbol	Min.	Max.	Unit	Note
Power Supply for Logic	$V_{DD} - V_{SS}$	-0.3	7.0	Volt	--
Power Supply for LCD	$V_{DD} - V_O$	0	15.0	Volt	--
Input Voltage	V_{IN}	-0.3	$V_{DD} + 0.3$	Volt	--
Supplier current for LED backlight	I_{LED}	--	140	mA	--

Note: Operator should be grounded during handling LCM.

(2) Environmental Absolute Maximum Ratings

Item	Normal Temperature				Wide Temperature			
	Operating		Storage		Operating		Storage	
	Max.	Min.	Max.	Min.	Max.	Min.	Max.	Min.
Ambient Temperature	0°C	+50°C	-20°C	+70°C	-20°C	+70°C	-30°C	+80°C
Humidity (without condensation)	Note 2, 4		Note 3, 5		Note 4, 5		Note 4, 6	

Note 2: $T_a \leq 50^\circ\text{C}$: 80% RH max

$T_a > 50^\circ\text{C}$: Absolute humidity must be lower than the humidity of 85% RH at 50°C

Note 3: T_a at -20°C will be < 48hrs at 70°C will be < 120hrs

Note 4: Background color changes slightly depending on ambient temperature. This phenomenon is reversible.

Note 5: $T_a \leq 70^\circ\text{C}$: 75RH max

$T_a > 70^\circ\text{C}$: absolute humidity must be lower than the humidity of 75% RH at 70°C

Note 6: T_a at -30°C will be < 48hrs, at 80°C will be < 120hrs



Messrs.					
Product Specification	Model	NMTC-S0802XRYHS-13	Rev. No.	Issued Date.	Page.
			A	August. 16, 17	7 / 29

ELECTRICAL CHARACTERISTICS

Item	Symbol	Condition	Min.	Typ.	Max.	Unit
Power Supply for Logic	$V_{DD} - V_{SS}$	--	2.7	4.5	5.5	Volt
Input Voltage	V_{IL}	L level	V_{SS}	$0.2 V_{DD}$	--	Volt
	V_{IH}	H level	$0.8 V_{DD}$	V_{DD}	--	Volt
LCM Recommend LCD Module Driving Voltage	$V_{DD} - V_O = 4.4$	$T_a = 0^\circ\text{C}$	4.4	4.56	4.7	Volt
		$T_a = 25^\circ\text{C}$	4.2	4.40	4.6	
		$T_a = 50^\circ\text{C}$	3.9	4.02	4.2	
Power Supply Current for LCM	I_{DD}^* (B/L OFF)	$V_{DD} = 4.5\text{V}$ $V_{DD} - V_O = 4.4\text{V}$ $V_{LED} = 4.2\text{V}$ $T_a = 25^\circ\text{C}$	--	1.5	2.0	mA
	I_{LED}		--	70	105	

* I_{DD} including current for logic circuit and LCD panel

OPTICAL CHARACTERISTICS

Item	Symbol	Condition	Min.	Typ	Max.	Unit	note
Viewing Angle Range	Φ_f (12 o'clock)	When $Cr \geq 2$	--	40	--	Degree	9, 10
	Φ_b (6 o'clock)		--	45	--		
	Φ_l (9 o'clock)		--	40	--		
	Φ_r (3 o'clock)		--	40	--		
Rise Time	T_r	$V_{DD} - V_O = 4.4\text{V}$ $T_a = 25^\circ\text{C}$	--	70	90	mS	--
Fall Time	T_f		--	150	200		
Contrast	Cr		--	7.3	--		



Messrs.					
Product Specification	Model	NMTC-S0802XRYHS-13	Rev. No.	Issued Date.	Page.
			A	August. 16, 17	8 / 29

MECHANICAL SPECIFICATION

Product No.		NMTC-S0802XRYHS-13
Module Size		58.0 (W) mm × 32.0 (H) mm × 18.0 (D) mm Max
Display Format		8 characters × 2 lines
Character Size		2.96 mm × 5.56 mm
Character Pitch		3.55 mm × 5.94 mm
Dot Size		0.56 (W) mm × 0.66 (H) mm
Dot Pitch		0.60 (W) mm × 0.70 (H) mm
Duty Ratio		1/16 Duty
Character Font Table		<input checked="" type="checkbox"/> English <input type="checkbox"/> European <input type="checkbox"/> Other_____
LCD Display Mode	STN	<input type="checkbox"/> Gray Mode <input checked="" type="checkbox"/> Yellow Mode <input type="checkbox"/> Blue Mode
	FSTN	<input type="checkbox"/> Black & White (Normally White / Positive Image)
		<input type="checkbox"/> Black & White (Normally White / Negative Image)
	Rear Polarizer	<input checked="" type="checkbox"/> Reflective <input type="checkbox"/> Transflective <input type="checkbox"/> Transmissive
Viewing Direction		<input checked="" type="checkbox"/> 6 O'clock <input type="checkbox"/> 12 O'clock <input type="checkbox"/> 3 O'clock <input type="checkbox"/> 9 O'clock
Backlight		<input checked="" type="checkbox"/> Without <input type="checkbox"/> CCFL <input type="checkbox"/> EL <input type="checkbox"/> LED
Controller		ST 7066
DC/DC Converter		Without
CCFL Inverter		Without
EL Driver		Without



Messrs.					
Product Specification	Model	NMTC-S0802XRYHS-13	Rev. No.	Issued Date.	Page.
			A	August. 16, 17	9 / 29

INTERFACE PIN ASSIGNMENT

PIN NO.	PIN OUT	DESCRIPTION
1.	V _{SS}	Ground
2.	V _{DD}	Logic Circuit Power Supply
3.	V _O	Power Supply For LCD Panel
4.	RS	Data / Instruction Register Select
5.	R/W	Read / Write Select
6.	E	Enable Signal
7.	DB0	3 – State I/O Data Bus
8.	DB1	
9.	DB2	
10.	DB3	
11.	DB4	
12.	DB5	
13.	DB6	
14.	DB7	

Schematic and Jumper Explanation for LED backlight:

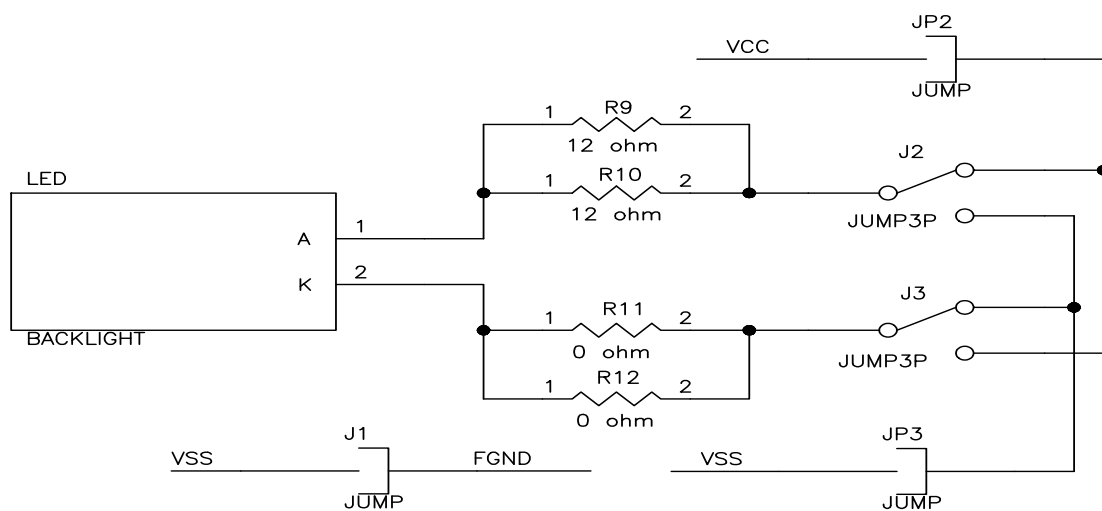

Messrs.					
Product Specification	Model	NMTC-S0802XRYHS-13	Rev. No.	Issued Date.	Page.
			A	August. 16, 17	10 / 29

[Note 7] Definition of Operation Voltage (Vop)

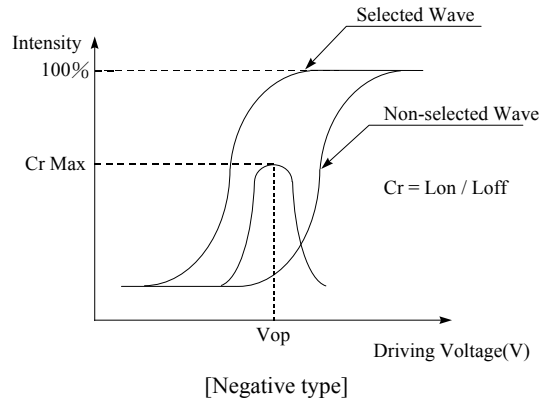
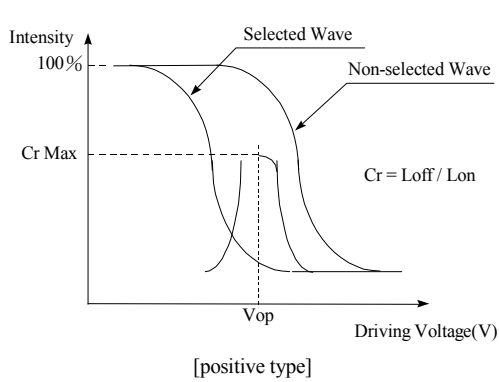

[Note 8] Definition of Response Time (Tr, Tf)

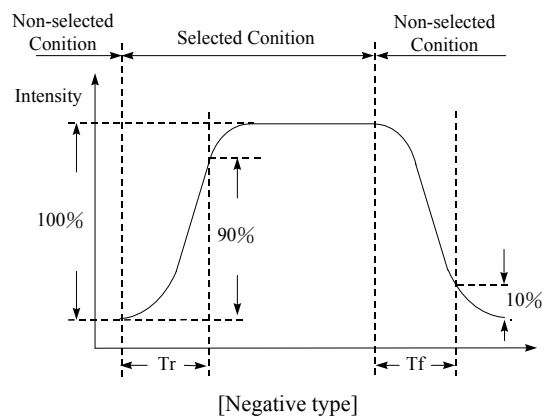
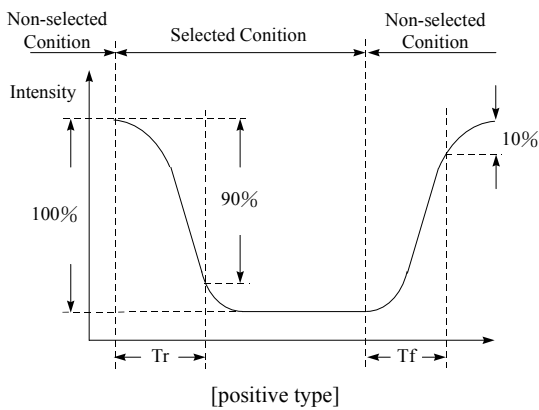

Conditions:

Operating Voltage: Vop
Frame Frequency: 64 Hz

Viewing Angle (θ, φ): 0°, 0°
Driving Wave form: 1/N duty, 1/a bias

[Note 9] Definition of Viewing Direction

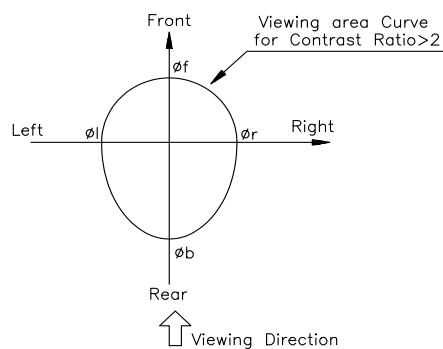

Messrs.					
Product Specification	Model	NMTC-S0802XRYHS-13	Rev. No.	Issued Date.	Page.
			A	August. 16, 17	11 / 29

[Note 10] Definition of viewing angle

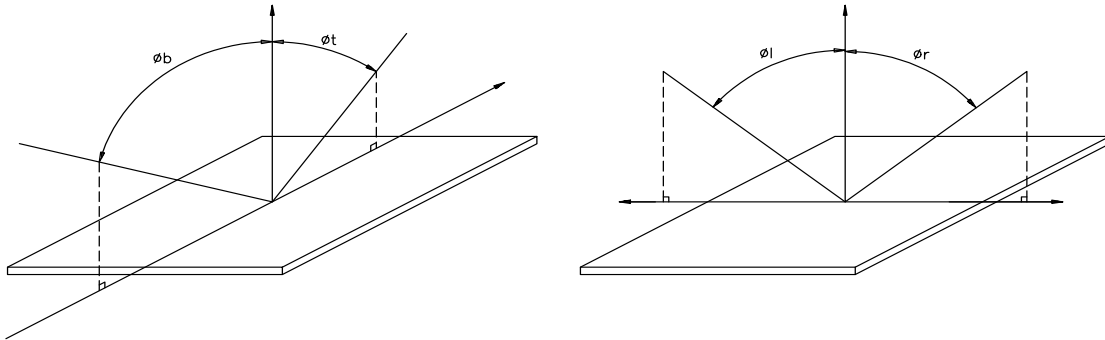

[Note 11] Description of Measuring Equipment

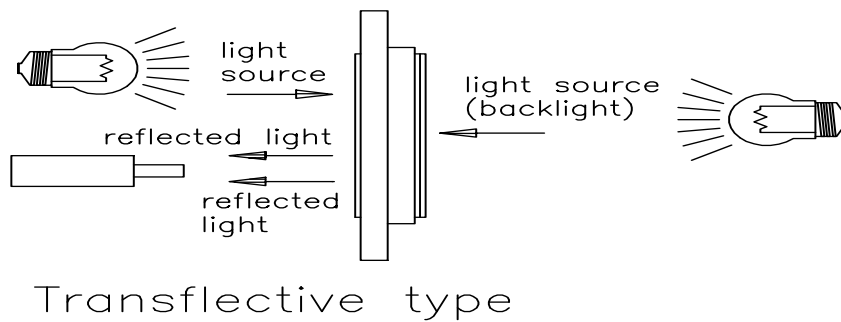
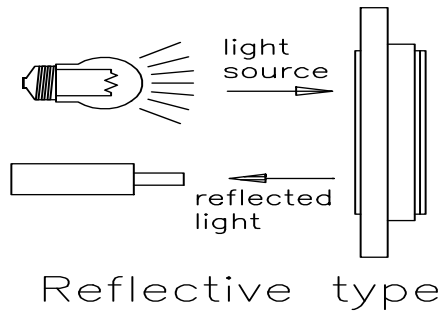

Messrs.					
Product Specification	Model	NMTC-S0802XRYHS-13	Rev. No.	Issued Date.	Page.
			A	August. 16, 17	12 / 29

BLOCK DIAGRAM

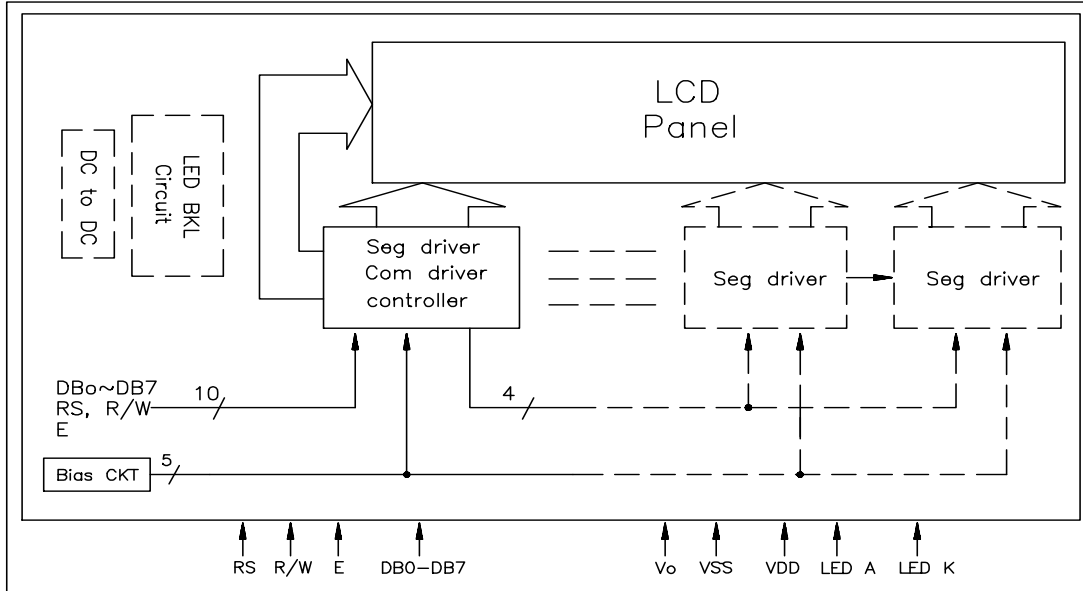

POWER SUPPLY

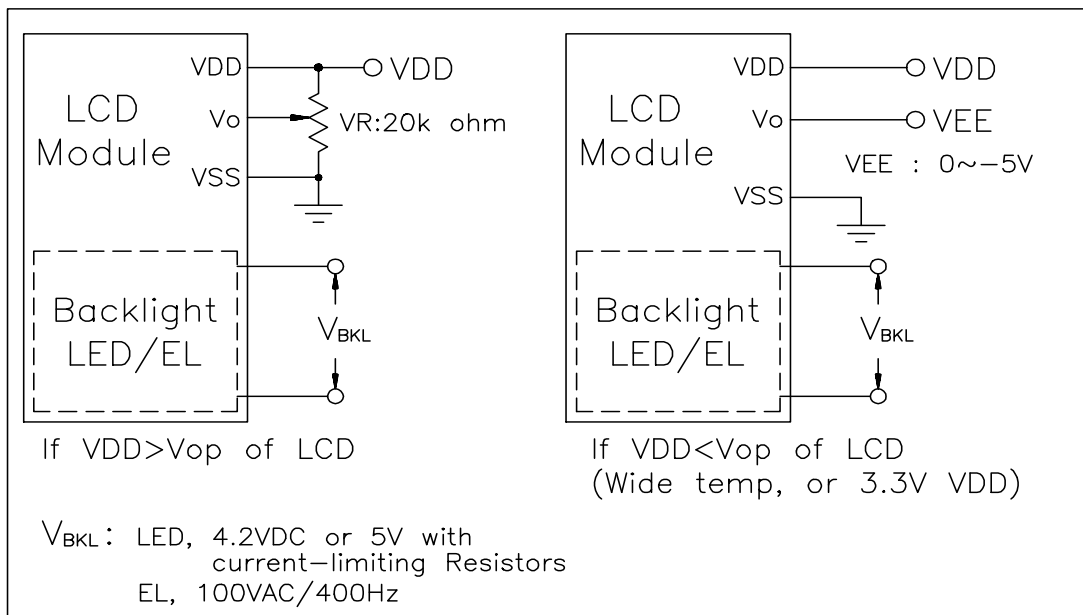

Messrs.					
Product Specification	Model	NMTC-S0802XRYHS-13	Rev. No.	Issued Date.	Page.
			A	August. 16, 17	13 / 29

TIMING CHARACTERISTICS

AC Characteristics ($V_{SS} = 0V$, $V_{DD} = 4.5V$ to $5.0V$, $T_a = 0$ to $50^{\circ}C$)

Mode	Characteristic	Symbol	Min.	Typ.	Max.	Unit
Write Mode	E Cycle Time	t_C	500	--	--	ns
	E Rise / Fall Time	t_R, t_F	--	--	20	ns
	E Pulse Width (High, Low)	t_W	230	--	--	ns
	R/W And RS Setup Time	t_{SU1}	40	--	--	ns
	R/W And RS Hold Time	t_{H1}	10	--	--	ns
	Data Setup Time	t_{SU2}	80	--	--	ns
	Data Hold Time	t_{H2}	10	--	--	ns
Read Mode	E Cycle Time	t_C	500	--	--	ns
	E Rise / Fall Time	t_R, t_F	--	--	20	ns
	E Pulse Width (High, Low)	t_W	230	--	--	ns
	R/W And RS Setup Time	t_{SU}	40	--	--	ns
	R/W And RS Hold Time	t_H	10	--	--	ns
	Data Setup Time	t_D	--	--	120	ns
	Data Hold Time	t_{DH}	5	--	--	ns

AC Characteristics ($V_{SS} = 0V$, $V_{DD} = 2.7V$ to $4.5V$, $T_a = 0$ to $50^{\circ}C$)

Mode	Characteristic	Symbol	Min.	Typ.	Max.	Unit
Write Mode	E Cycle Time	t_C	1000	--	--	ns
	E Rise / Fall Time	t_R, t_F	--	--	25	ns
	E Pulse Width (High, Low)	t_W	450	--	--	ns
	R/W And RS Setup Time	t_{SU1}	60	--	--	ns
	R/W And RS Hold Time	t_{H1}	20	--	--	ns
	Data Setup Time	t_{SU2}	195	--	--	ns
	Data Hold Time	t_{H2}	10	--	--	ns
Read Mode	E Cycle Time	t_C	1000	--	--	ns
	E Rise / Fall Time	t_R, t_F	--	--	25	ns
	E Pulse Width (High, Low)	t_W	450	--	--	ns
	R/W And RS Setup Time	t_{SU}	60	--	--	ns
	R/W And RS Hold Time	t_H	20	--	--	ns
	Data Setup Time	t_D	--	--	360	ns
	Data Hold Time	t_{DH}	5	--	--	ns



Messrs.					
Product Specification	Model	NMTC-S0802XRYHS-13	Rev. No.	Issued Date.	Page.
			A	August. 16, 17	14 / 29

READ / WRITE TIMING CHART

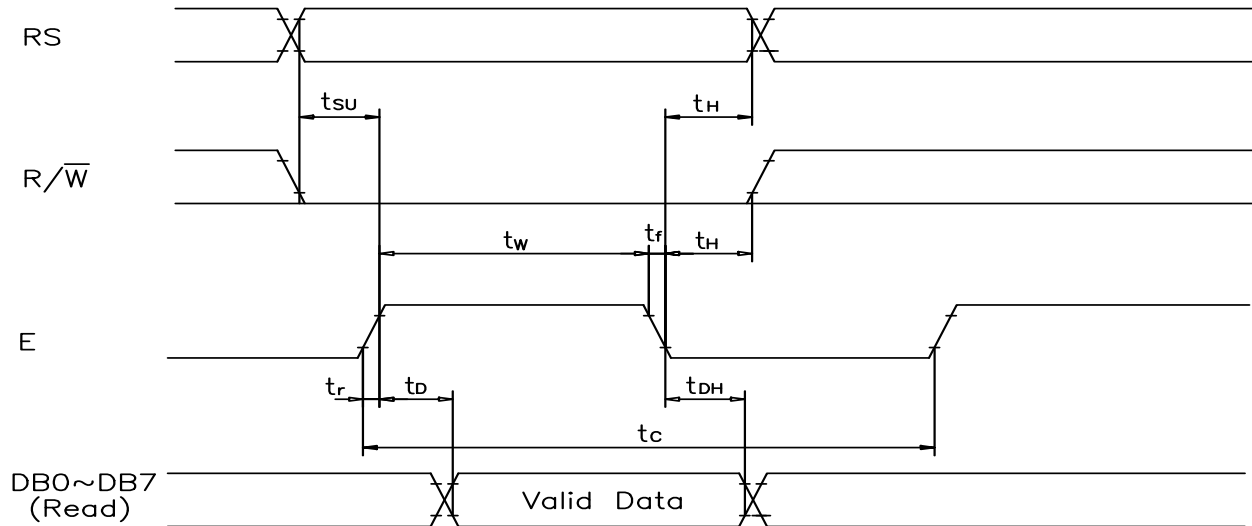
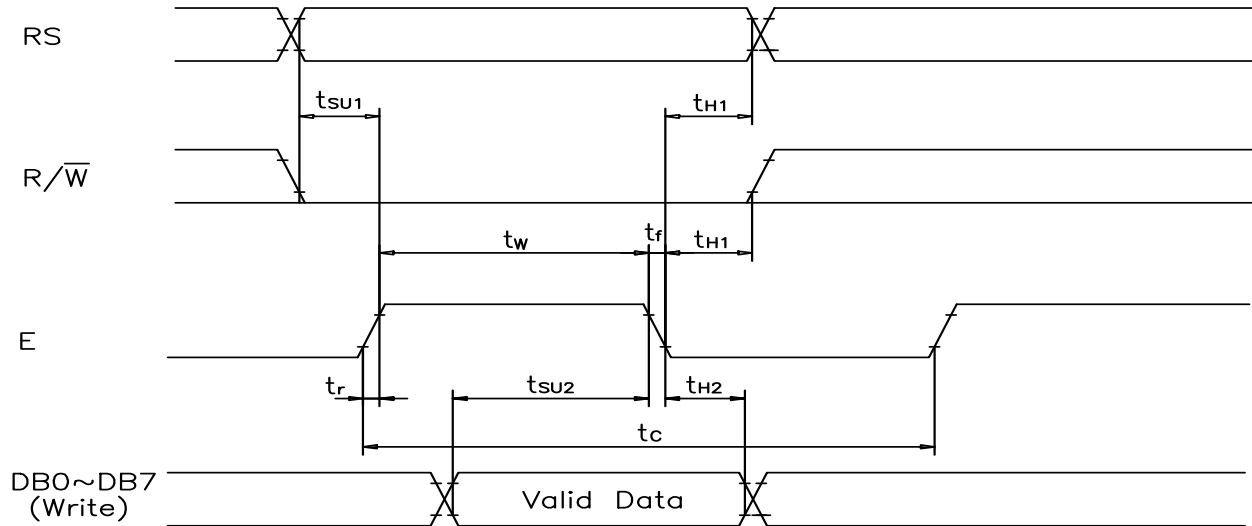

Messrs.					
Product Specification	Model	NMTC-S0802XRYHS-13	Rev. No.	Issued Date.	Page.
			A	August. 16, 17	15 / 29

COMMANDS

Instruction	Instruction Code										Description	Execution time(f_{osc} is 270kHz)	
	RS	R/W	DB 7	DB 6	DB 5	DB 4	DB 3	DB 2	DB 1	DB 0			
Clear Display	0	0	0	0	0	0	0	0	0	0	1	Write "20H" to DDRAM. and set DDRAM address to "00H" from AC	1.53mS
Return Home	0	0	0	0	0	0	0	0	0	1	*	Set DDRAM address to "00H" from AC and return cursor to its original position if shifted. The contents of DDRAM are not changed.	1.53mS
Entry Mode	0	0	0	0	0	0	0	0	1	I/D	SH	Assign cursor moving direction and make shift of entire display enable.	39 μ S
Display ON/OFF	0	0	0	0	0	0	0	1	D	C	B	Set display (D), cursor (C), and blinking of cursor (B) on/off control bit.	39 μ S
Cursor or Display Shift	0	0	0	0	0	1	S/C	R/L	*	*	*	Set cursor moving and display shift control bit, and the direction, without changing DDRAM data.	39 μ S
Function Set	0	0	0	0	1	DL	N	F	*	*	*	Set interface data length (DL: 4-bit / 8-bit), numbers of display line (N: 1-line / 2-line), display font type(F: 5 X 8 dots / 5 X 11 dots)	39 μ S
Set CG RAM Address	0	0	0	1	AC 5	AC 4	AC 3	AC 2	AC 1	AC 0	AC 0	Set CGRAM address in address counter.	39 μ S
Set DD RAM Address	0	0	1	AC 6	AC 5	AC 4	AC 3	AC 2	AC 1	AC 0	AC 0	Set DDRAM address in address counter.	39 μ S
Read Busy Flag and Address	0	1	BF	AC 6	AC 5	AC 4	AC 3	AC 2	AC 1	AC 0	AC 0	Whether during internal operation or not can be known by reading BF. The contents of address counter can also be read.	0 μ S
Write Data to RAM	1	0	D7	D6	D5	D4	D3	D2	D1	D0	D0	Write data into internal RAM (DDRAM / CGRAM).	43 μ S
Read Data from RAM	1	1	D7	D6	D5	D4	D3	D2	D1	D0	D0	Read data from internal RAM (DDRAM / CGRAM).	43 μ S

* means don't care



Messrs.					
Product Specification	Model	NMTC-S0802XRYHS-13	Rev. No.	Issued Date.	Page.
			A	August. 16, 17	16 / 29

COMMANDS DESCRIPTION

Clear Display

RS	R/W	DB7	DB6	DB5	DB4	DB3	DB2	DB1	DB0
0	0	0	0	0	0	0	0	0	1

Clear all the display data by writing "20H" (space code) to all DDRAM address, and set DDRAM address to "00H"

into AC (address counter). Return cursor to the original status. namely, bring the cursor to the left edge on first line

of the display. Make entry mode increment (I/D = "1").

Return Home

RS	R/W	DB7	DB6	DB5	DB4	DB3	DB2	DB1	DB0
0	0	0	0	0	0	0	0	1	*

Return Home is cursor return home instruction. Set DDRAM address to "00H" into the address counter. Return

cursor to its original site and return display to its original status, if shifted. Content of DDRAM is not changed.

Entry Mode Set

RS	R/W	DB7	DB6	DB5	DB4	DB3	DB2	DB1	DB0
0	0	0	0	0	0	0	1	I/D	SH

Set the moving direction of cursor and display.

I/D: Increment / decrement of DDRAM address (cursor or blink)

When I/D = "High", cursor/blink moves to right and DDRAM address is increased by 1.

When I/D = "Low", cursor/blink moves to left and DDRAM address is decreased by 1.

* CGRAM operates the same as DDRAM, when read from or write to CGRAM.

SH: Shift of entire display

When DDRAM read (CGRAM read/write) operation or SH = "Low", shift of entire display is not performed.

If SH = "High" and DDRAM write operation, shift of entire display is performed according to I/D value (I/D =

"1", shift left, I/D = "0": shift right).



Messrs.					
Product Specification	Model	NMTC-S0802XRYHS-13	Rev. No.	Issued Date.	Page.
			A	August. 16, 17	17 / 29

Display ON/OFF Control

RS	R/W	DB7	DB6	DB5	DB4	DB3	DB2	DB1	DB0
0	0	0	0	0	0	1	D	C	B

Control display / cursor/blink ON/OFF 1 bit register.

D: Display ON/OFF control bit

When D = "High", entire display is turned on.

When D = "Low", display is turned off, but display data is remained in DDRAM.

C: Cursor ON/OFF control bit

When C = "High", cursor is turned on.

When C = "Low", cursor is disappeared in current display, but I/D register remains its data.

B: Cursor Blink ON/OFF control bit

When B = "High", cursor blink is on, that performs alternate between all the high data and display character at the cursor position.

When B = "Low", blink is off.

Cursor or Display Shift

RS	R/W	DB7	DB6	DB5	DB4	DB3	DB2	DB1	DB0
0	0	0	0	0	1	S/C	R/L	*	*

Without writing or reading of display data, shift right / left cursor position or display.

This instruction is used to correct or search display data. (Refer to Table 4)

During 2 – line mode display, cursor moves to the 2nd line after 40th digit of 1st line.

Note that display shift is performed simultaneously in all the line.

When displayed data is shifted repeatedly, each line shifted individually.

When display shift is performed, the contents of address counter are not changed.

S/C	R/L	Operation
0	0	Shift cursor to the left, AC is decreased by 1.
0	1	Shift cursor to the right, AC is increased by 1.
1	0	Shift all of the display to the left, cursor moves according to the display.
1	1	Shift all of the display to the right, cursor moves according to the display.



Messrs.					
Product Specification	Model	NMTC-S0802XRYHS-13	Rev. No.	Issued Date.	Page.
			A	August. 16, 17	18 / 29

Function Set

RS	R/W	DB7	DB6	DB5	DB4	DB3	DB2	DB1	DB0
00	0	0	0	1	DL	N	F	*	*

DL: Interface data length control bit

When DL = "High", it means 8 – bit bus mode with MPU.

When DL = "Low", it means 4 – bit bus mode with MPU. So to speak, DL is a signal to select 8 – bit or 4 – bit bus mode. When 4 – bit bus mode, it needs to transfer 4 – bit data by two times.

N: Display line number control bit

When N = "Low", it means 1 – line display mode.

When N = "High", 2 – line display mode is set.

F: Display font type control bit

When F = "Low", it means 5 X 8 dots format display mode

When F = "High", 5 x 11 dots format display mode.

Set CG RAM Address

RS	R/W	DB7	DB6	DB5	DB4	DB3	DB2	DB1	DB0
0	0	0	1	AC5	AC4	AC3	AC2	AC1	AC0

Set CGRAM address to AC.

This instruction makes CGRAM data available from MPU.

Set DD RAM Address

RS	R/W	DB7	DB6	DB5	DB4	DB3	DB2	DB1	DB0
0	0	1	AC6	AC5	AC4	AC3	AC2	AC1	AC0

Set DDRAM address to AC.

This instruction makes DDRAM data available from MPU.

When 1 – line display mode (N = 0), DDRAM address is from "00H" to "4FH".

In 2 – line display mode (N = 1), DDRAM address in the 1st line is from "00H" to "27H", and DDRAM address in the 2nd line is from "40H" to "67H".



Messrs.					
Product Specification	Model	NMTC-S0802XRYHS-13	Rev. No.	Issued Date.	Page.
			A	August. 16, 17	19 / 29

Read Busy Flag and Address

RS	R/W	DB7	DB6	DB5	DB4	DB3	DB2	DB1	DB0
0	1	BF	AC6	AC5	AC4	AC3	AC2	AC1	AC0

This instruction shows whether ST7066 is in internal operation or not. If the resultant BF is High, it means the internal operation is in progress and you have to wait until BF to be Low, and then the next instruction can be performed. In this instruction you can read also the value of address counter.

Write Data to RAM

RS	R/W	DB7	DB6	DB5	DB4	DB3	DB2	DB1	DB0
1	0	D7	D6	D5	D4	D3	D2	D1	D0

Write binary 8 – bit data to DDRAM / CGRAM.

The selection of RAM from DDRAM, CGRAM, is set by the previous address set instruction: DDRAM address set, CGRAM address set. RAM set instruction can also determine the AC direction to RAM. After write operation, the address is automatically increased / decreased by 1, according to the entry mode.

Read Data to RAM

RS	R/W	DB7	DB6	DB5	DB4	DB3	DB2	DB1	DB0
1	0	D7	D6	D5	D4	D3	D2	D1	D0

Read binary 8 – bit data from DDRAM/CGRAM.

The selection of RAM is set by the previous address set instruction. If address set instruction of RAM is not performed before this instruction, the data that read first is invalid, because the direction of AC is not determined.

If you read RAM data several times without RAM address set instruction before read operation, you can get correct RAM data from the second, but the first data would be incorrect, because there is no time margin to transfer RAM data.

In case of DDRAM read operation, cursor shift instruction plays the same role as DDRAM address set instruction : it also transfers RAM data to output data register. After read operation address counter is automatically increased/decreased by 1 according to the entry mode. After CGRAM read operation, display shift may not be executed correctly.

NOTE: In case of RAM write operation, after this AC is increased / decreased by 1 like read operation. In this time,

AC indicates the next address position, but you can read only the previous data by read instruction.



Messrs.					
Product Specification	Model	NMTC-S0802XRYHS-13	Rev. No.	Issued Date.	Page.
			<i>A</i>	<i>August. 16, 17</i>	<i>20 / 29</i>

DD RAM ADDRESSING

For 16 × 1 or 8 × 1 Display

Character	1	2	3	4	5	6	7	8	9	10	11	12	13	14	15	16
DD RAM Address	00	01	02	03	04	05	06	07	40	41	42	43	44	45	46	47

For 16 × 2 or 8 × 2 Display

Character	1	2	3	4	5	6	7	8	9	10	11	12	13	14	15	16
DD RAM Address	00	01	02	03	04	05	06	07	08	09	0A	0B	0C	0D	0E	0F
	40	41	42	43	44	45	46	47	48	49	4A	4B	4C	4D	4E	4F

For 16 × 4 Display

Character	1	2	3	4	5	6	7	8	9	10	11	12	13	14	15	16
DD RAM Address	00	01	02	03	04	05	06	07	08	09	0A	0B	0C	0D	0E	0F
	40	41	42	43	44	45	46	47	48	49	4A	4B	4C	4D	4E	4F
	10	11	12	13	14	15	16	17	18	19	1A	1B	1C	1D	1E	1F
	50	51	52	53	54	55	56	57	58	59	5A	5B	5C	5D	5E	5F

For 20 × 2 Display

Character	1	2	3	4	5	6	7	8	9	10	17	18	19	20
DD RAM Address	00	01	02	03	04	05	06	07	08	09	10	11	12	13
	40	41	42	43	44	45	46	47	48	49	50	51	52	53



Messrs.					
Product Specification	Model	NMTC-S0802XRYHS-13	Rev. No.	Issued Date.	Page.
			A	August. 16, 17	21 / 29

For 20 × 4 Display

Character	1	2	3	4	5	6	7	8	9	10	17	18	19	20
	00	01	02	03	04	05	06	07	08	09	10	11	12	13
DD RAM Address	40	41	42	43	44	45	46	47	48	49	50	51	52	53
	14	15	16	17	18	19	1A	1B	1C	1D	24	25	26	27
	54	55	56	57	58	59	5A	5B	5C	5D	64	65	66	67

For 40 × 2 Display

Character	1	2	3	4	5	6	7	8	9	10	37	38	39	40
DD RAM Address	00	01	02	03	04	05	06	07	08	09	24	25	26	27
Address	40	41	42	43	44	45	46	47	48	49	64	65	66	67

For 40 × 4 Display

Character	E	1	2	3	4	5	6	7	8	9	10	37	38	39	40
DD RAM Address	E1	00	01	02	03	04	05	06	07	08	09	24	25	26	27
		40	41	42	43	44	45	46	47	48	49	64	65	66	67
Address	E2	00	01	02	03	04	05	06	07	08	09	24	25	26	27
		40	41	42	43	44	45	46	47	48	49	64	65	66	67



Messrs.					
Product Specification	Model	NMTC-S0802XRYHS-13	Rev. No.	Issued Date.	Page.
			A	August. 16, 17	22 / 29

CG RAM MAPPING

Character Code (DD RAM data)								CG RAM Address						Character Patterns (CG RAM data)																																																
7	6	5	4	3	2	1	0	5	4	3	2	1	0	7	6	5	4	3	2	1	0																																									
High				Low				High			Low			High				Low																																												
0 0 0 0 * 0 0 0								0 0 0						* * *								←Character Pattern																																								
														<table border="1"> <tr><td>0</td><td>1</td><td>1</td><td>0</td><td>0</td></tr> <tr><td>1</td><td>0</td><td>0</td><td>1</td><td>0</td></tr> <tr><td>0</td><td>0</td><td>1</td><td>0</td><td>0</td></tr> <tr><td>0</td><td>1</td><td>0</td><td>0</td><td>0</td></tr> <tr><td>1</td><td>1</td><td>1</td><td>1</td><td>0</td></tr> <tr><td>0</td><td>0</td><td>0</td><td>0</td><td>0</td></tr> <tr><td>0</td><td>0</td><td>0</td><td>0</td><td>0</td></tr> <tr><td>0</td><td>0</td><td>0</td><td>0</td><td>0</td></tr> </table>								0	1	1	0	0	1	0	0	1	0	0	0	1	0	0	0	1	0	0	0	1	1	1	1	0	0	0	0	0	0	0	0	0	0	0	0	0	0	0	0	←Cursor
0	1	1	0	0																																																										
1	0	0	1	0																																																										
0	0	1	0	0																																																										
0	1	0	0	0																																																										
1	1	1	1	0																																																										
0	0	0	0	0																																																										
0	0	0	0	0																																																										
0	0	0	0	0																																																										
0 0 0 0 * 0 0 1								0 0 1						* * *								←Character Pattern																																								
														<table border="1"> <tr><td>1</td><td>1</td><td>1</td><td>1</td><td>1</td></tr> <tr><td>1</td><td>0</td><td>0</td><td>0</td><td>1</td></tr> <tr><td>1</td><td>0</td><td>1</td><td>0</td><td>1</td></tr> <tr><td>1</td><td>0</td><td>1</td><td>1</td><td>1</td></tr> <tr><td>1</td><td>0</td><td>1</td><td>0</td><td>1</td></tr> <tr><td>1</td><td>0</td><td>0</td><td>0</td><td>1</td></tr> <tr><td>1</td><td>1</td><td>1</td><td>1</td><td>1</td></tr> <tr><td>0</td><td>0</td><td>0</td><td>0</td><td>0</td></tr> </table>								1	1	1	1	1	1	0	0	0	1	1	0	1	0	1	1	0	1	1	1	1	0	1	0	1	1	0	0	0	1	1	1	1	1	1	0	0	0	0	0	←Cursor
1	1	1	1	1																																																										
1	0	0	0	1																																																										
1	0	1	0	1																																																										
1	0	1	1	1																																																										
1	0	1	0	1																																																										
1	0	0	0	1																																																										
1	1	1	1	1																																																										
0	0	0	0	0																																																										
⋮								⋮						⋮																																																
0 0 0 0 * 1 1 1								1 1 1						* * *								←Character Pattern																																								
														<table border="1"> <tr><td>1</td><td>1</td><td>1</td><td>1</td><td>1</td></tr> <tr><td>1</td><td>0</td><td>0</td><td>0</td><td>1</td></tr> <tr><td>1</td><td>1</td><td>1</td><td>0</td><td>1</td></tr> <tr><td>1</td><td>0</td><td>0</td><td>0</td><td>1</td></tr> <tr><td>1</td><td>0</td><td>1</td><td>1</td><td>1</td></tr> <tr><td>1</td><td>0</td><td>0</td><td>0</td><td>1</td></tr> <tr><td>1</td><td>1</td><td>1</td><td>1</td><td>1</td></tr> <tr><td>0</td><td>0</td><td>0</td><td>0</td><td>0</td></tr> </table>								1	1	1	1	1	1	0	0	0	1	1	1	1	0	1	1	0	0	0	1	1	0	1	1	1	1	0	0	0	1	1	1	1	1	1	0	0	0	0	0	←Cursor
1	1	1	1	1																																																										
1	0	0	0	1																																																										
1	1	1	0	1																																																										
1	0	0	0	1																																																										
1	0	1	1	1																																																										
1	0	0	0	1																																																										
1	1	1	1	1																																																										
0	0	0	0	0																																																										



Messrs.					
Product Specification	Model	NMTC-S0802XRYHS-13	Rev. No.	Issued Date.	Page.
			A	August. 16, 17	23 / 29

CHARACTER FONT TABLE

Upper 4 bits Lower 4 bits	0000	0001	0010	0011	0100	0101	0110	0111	1000	1001	1010	1011	1100	1101	1110	1111
0000	CG RAM (1)			0	a	P	`	P				—	9	E	e	p
0001	CG RAM (2)		!	1	A	Q	a	q			a	7	7	4	ä	q
0010	CG RAM (3)		"	2	B	R	b	r			r	4	U	X	P	0
0011	CG RAM (4)		#	3	C	S	c	s			J	U	T	E	e	∞
0100	CG RAM (5)		\$	4	D	T	d	t			\	I	T	h	W	0
0101	CG RAM (6)		%	5	E	U	e	u			=	o	+	1	0	0
0110	CG RAM (7)		&	6	F	V	f	v			9	h	2	0	P	E
0111	CG RAM (8)		'	7	G	W	g	w			7	+	2	7	9	π
1000	CG RAM (1)		(8	H	X	h	x			4	o	*	1	π	∞
1001	CG RAM (2))	9	I	Y	i	y			0	T	J	U	1	U
1010	CG RAM (3)		*	0	J	Z	j	z			E	o	N	V	j	7
1011	CG RAM (4)		+	1	K	0	k	0			7	o	o	o	0	7
1100	CG RAM (5)		,	<	L	*	l	l			h	o	o	o	0	7
1101	CG RAM (6)		—	=	M	J	m	j			7	2	2	2	0	7
1110	CG RAM (7)		.	>	N	^	n	+			0	o	o	0	0	7
1111	CG RAM (8)		/	?	O	_	o	+			U	U	U	U	0	7



Messrs.					
Product Specification	Model	NMTC-S0802XRYHS-13	Rev. No.	Issued Date.	Page.
			A	August. 16, 17	24 / 29

RELIABILITY TEST

No	Item	Conditions		Note
1.	High Temp. Operation	70°C	240 Hr	--
2.	High Temp. Storage	80°C	240 Hr	--
3.	Low Temp. Operation	-20°C	240 Hr	--
4.	Low Temp. Storage	-30°C	240 Hr	--
5.	High Temp. / Humid Storage	40°C 90% RH	240 Hr	--
6.	Thermal Shock	-20°C, 30min +70°C, 30min	10 cycles	--
7.	Vibration Test (IEC – 68 – 2 – 6)	Frequency: 10 ~ 55 Hz Duration: 20 times, 6 min / time Amplitude: 0.75 mm	--	--
8.	Shock (IEC 68 – 2 – 27)	Duration: 11 mS Acceleration: 100g	--	X, Y, Z direction

APPEARANCE CHECK

CONDIITON OF APPEARANCE CHECK:

- (1) Specimen shall be checked by eyes in distance of 30cm under 40w – fluorescence lamp.
- (2) Checking direction shall be in 45 degree from perpendicular line op specimen surface.

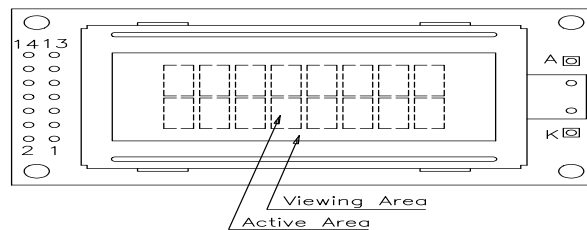

Messrs.					
Product Specification	Model	NMTC-S0802XRYHS-13	Rev. No.	Issued Date.	Page.
			A	August. 16, 17	25 / 29

HANDLING PRECAUTIONS

- (1) Treat polarizer very carefully since it is easy to be damaged.
- (2) When cleaning the display surface, use soft cloth (e.g. gauss) with a solvent (recommended below) and wipe lightly.
 - ◆ ethyl alcohol
 - ◆ iso – procolol

Do not wipe the display surface with dry or hard materials that will damage the polarizer surface.

Do not use the following solvents:

- ◆ water
- ◆ ketone
- ◆ aromatics

- (3) Direct current causes electro – chemical reaction with remarkable degradation of the display quality.
Give careful consideration to prevent direct current at ON/OFF timing and during Operation.
- (4) Avoid strong shock and drop from the height.
- (5) To prevent LCD panels from degradation, do not operate or store them exposed directly to sunshine or high temperature / humidity.
- (6) Give careful consideration to avoid electrical static discharge with causes uneven contrast.
- (7) Even a small condensation on the contact pads (terminals) causes electro-chemical reaction Which makes missing row and column. Give careful attention to avoid condensation.
When assembling with zebra connector, clean the surface of the pads with alcohol and keep the air very clean.



Messrs.					
Product Specification	Model	NMTC-S0802XRYHS-13	Rev. No.	Issued Date.	Page.
			A	August. 16, 17	26 / 29

LCD PRODUCT QUALITY STANDARD

DISPLAY APPEARANCE

No	Item	Criteria
1.	Inclusions (Black spot, white spot, dust)	(1) Round type diameter mm (a*) no of defect* $a \leq 0.20$ neglect $0.20 < a \leq 0.35$ 5max $0.35 < a$ none (2) Linear type length mm (l) width mm (W) no. of defect na $W \leq 0.03$ neglect $1 \leq 3$ $0.03 < W \leq 0.08$ 6 $3 < l$ $0.08 < W$ none
2.	Scratch	1. Scratch on protective film is permitted. 2. Scratch on polarizer shall be as follow: (1) Round type diameter mm (a*) no of defect $a \leq 0.15$ neglect $0.15 < a \leq 0.20$ 2 max $0.20 < a$ none (2) Linear type be judged by 1. – (2) linear type
3.	Dent	Diameter < 1.5mm
4.	Bubble	Not exceeding 0.5mm average diameter is acceptable between glass and polarizing film
5.	Pin hole	$(a + b) / 2 \leq 0.15\text{mm}$ maximum number: ignored $0.15 < (a + b) / 2 \leq 0.20\text{mm}$ maximum number: 10



Messrs.					
Product Specification	Model	NMTC-S0802XRYHS-13	Rev. No.	Issued Date.	Page.
			A	August. 16, 17	27 / 29

No	Item	Criteria										
6.	Dot defect	$(a + b) / 2 \leq 0.20\text{mm}$ maximum number: ignored $0.20 < (a + b) / 2 \leq 0.30\text{mm}$ maximum number: 5 x = width										
7.	Contrast irregularity (spot)	<table> <tr> <td>Diameter spec</td> <td>no of defect</td> </tr> <tr> <td>$a \leq 0.50\text{mm}$</td> <td>neglect</td> </tr> <tr> <td>$0.50 < a \leq 0.75$</td> <td>5</td> </tr> <tr> <td>$0.75 < a \leq 1.00$</td> <td>3</td> </tr> <tr> <td>$1.00 < a$</td> <td>none</td> </tr> </table>	Diameter spec	no of defect	$a \leq 0.50\text{mm}$	neglect	$0.50 < a \leq 0.75$	5	$0.75 < a \leq 1.00$	3	$1.00 < a$	none
Diameter spec	no of defect											
$a \leq 0.50\text{mm}$	neglect											
$0.50 < a \leq 0.75$	5											
$0.75 < a \leq 1.00$	3											
$1.00 < a$	none											
8.	Dot width	Design width $\pm 15\%$										
9.	Color tone and uniformity	Obvious uneven color is not permitted										



Messrs.					
Product Specification	Model	NMTC-S0802XRYHS-13	Rev. No.	Issued Date.	Page.
			<i>A</i>	<i>August. 16, 17</i>	<i>28 / 29</i>

WARRANTY

This product has been manufactured to your company’s specifications as a part for use in your company’s general electronic products. It is guaranteed to perform according to delivery specifications. For any other use apart from general electronic equipment, we cannot take responsibility if the product is used in medical devices, nuclear power control equipment, aerospace equipment, fire and security systems, or any other applications in which there is a direct risk to human life and where extremely high levels of reliability are required. If the product is to be used in any of the above applications, we will need to enter into a separate product liability agreement.

- 1 13 months guarantee starts from the date code.
- 2 We cannot accept responsibility for any defect, which may arise from additional manufacturing of the product (including disassembly and reassembly), after product delivery.
- 3 We cannot accept responsibility for any defect, which may arise after the application of strong external force to the product.
- 4 We cannot accept responsibility for any defect, which may arise due to the application of static electricity after the product has passed your company’s acceptance inspection procedures.
- 5 We cannot accept responsibility for industrial property, which may arise through the use of your product, with exception to those issues relating directly to the structure or method of manufacturing of our product. Microtips-origin longer than one year from Microtips production.

DIMENSIONAL OUTLINES

- Please see the next page.....



REV.	DESCRIPTION	DRAWN	CHECK	APP'D	DATE

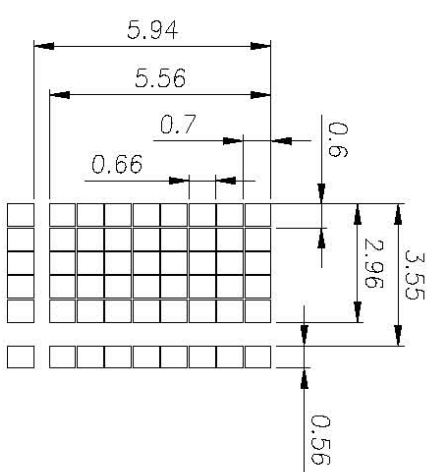
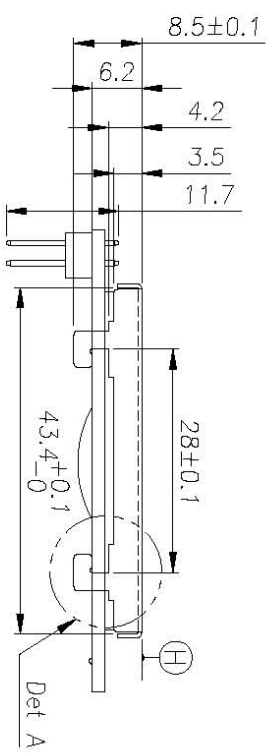
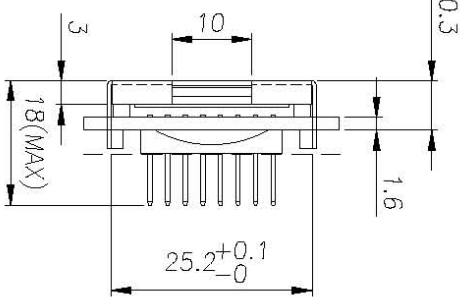
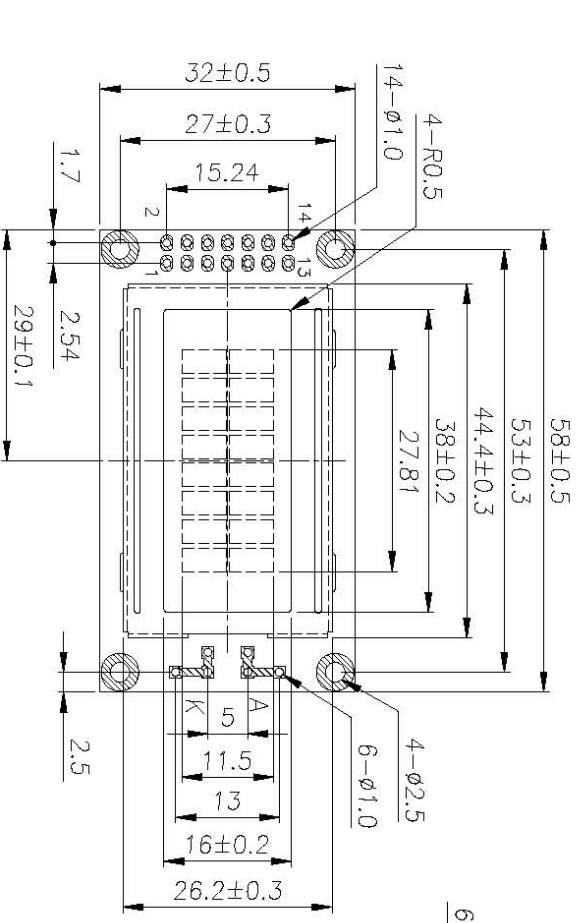

- Pin Assignment
- 1.:Vss
 - 2.:Vdd
 - 3.:Vo
 - 4.:RS
 - 5.:R/W
 - 6.:E
 - 7.:DB0
 - 14.:DB7

LCM Specification

Mode	STN YELLOW GREEN	Module Type	COB
Type	REFLECTIVE	Vop	4.5V
View	6 o'clock	Driver IC	SPLC780A2-01
Duty	1/16	O.Temp	-20°C~+70°C
Bias	1/5	S.Temp	-30°C~+80°C

NO.	M-0802XH	Q'TY	1	DATE:	04-06-09*	MATERIAL	電着黒
PART NAME	M-0802XH	APP'D		UNIT:MM		SCALE: 1/1	FINISH

Microtips Technology **Carol**

UNLESS OTHERWISE SPECIFIED
TOLERANCE ON FRACTIONS DECIMALS ANGLES
0.10 0.5°

PRODUCT: MTC-0802XH
DWG NO.: C00802X6
FILE: DWG\MTC\C00802X
SHEET 1 / 1 Rev: X



Компания «ЭлектроПласт» предлагает заключение долгосрочных отношений при поставках импортных электронных компонентов на взаимовыгодных условиях!

Наши преимущества:

- Оперативные поставки широкого спектра электронных компонентов отечественного и импортного производства напрямую от производителей и с крупнейших мировых складов;
- Поставка более 17-ти миллионов наименований электронных компонентов;
- Поставка сложных, дефицитных, либо снятых с производства позиций;
- Оперативные сроки поставки под заказ (от 5 рабочих дней);
- Экспресс доставка в любую точку России;
- Техническая поддержка проекта, помощь в подборе аналогов, поставка прототипов;
- Система менеджмента качества сертифицирована по Международному стандарту ISO 9001;
- Лицензия ФСБ на осуществление работ с использованием сведений, составляющих государственную тайну;
- Поставка специализированных компонентов (Xilinx, Altera, Analog Devices, Intersil, Interpoint, Microsemi, Aeroflex, Peregrine, Syfer, Eurofarad, Texas Instrument, Miteq, Cobham, E2V, MA-COM, Hittite, Mini-Circuits, General Dynamics и др.);

Помимо этого, одним из направлений компании «ЭлектроПласт» является направление «Источники питания». Мы предлагаем Вам помощь Конструкторского отдела:

- Подбор оптимального решения, техническое обоснование при выборе компонента;
- Подбор аналогов;
- Консультации по применению компонента;
- Поставка образцов и прототипов;
- Техническая поддержка проекта;
- Защита от снятия компонента с производства.



Как с нами связаться

Телефон: 8 (812) 309 58 32 (многоканальный)

Факс: 8 (812) 320-02-42

Электронная почта: org@eplast1.ru

Адрес: 198099, г. Санкт-Петербург, ул. Калинина, дом 2, корпус 4, литера А.