

## SPECIFICATION

- Part No. : **MA761.B.BICG.003**
- Product Name : Pantheon Antenna 4in1 MA761  
Screw-Mount [Permanent Mount]  
4G/3G/2G MIMO/ 2.4/5GHz MIMO
- Feature :
  - 2 x 4G/3G/2G MIMO Antenna (698~960MHz, 1710~2170MHz, 2300~2700MHz, 2900-3500MHz)
    - MIMO1 antenna
    - MIMO2 antenna
  - 2 x 2.4GHz/5GHz MIMO Antenna
    - MIMO1 antenna
    - MIMO2 antenna
- IP67 Waterproof  
High Efficiency / Peak Gain Outdoor Antenna  
RoHS Compliant



## **1. Introduction**

MA761 Pantheon antenna is an omni-directional, heavy-duty, fully IP67 waterproof external M2M antenna for use in telematics, transportation and remote monitoring applications.

This unique antenna delivers powerful MIMO antenna technology for LTE and Wi-Fi 802.11n and emerging 802.11ac for next generation high bandwidth telematics systems.

New fleet management and video location technology allows for real-time video uplink and downlink. High efficiency high gain MIMO antennas are necessary to achieve the high signal to noise ratio and throughput required to solve these challenges.

We have packed 4 high efficiency and gain antennas in an extremely robust IP67 direct mount antenna package with good isolation (10dB+)\*. The antenna has its own ground-plane and can radiate on any mounting environment like metal or plastic without affecting performance. The cables are low loss allowing for lengths of up to 10 meters (32 ' and 9.70 "), critical for buses, trains and other commercial transport applications.

Customized cables and connector version available.

## 2. Specification Table

4G/3G/2G MIMO								
Band	LTE 700	GSM 850	GSM 900	DCS	PCS	UMTS 1	LTE 2600	LTE 3500
Frequency (MHz)	698~824	824~894	880~960	1710~1880	1850~1990	1920~2170	2500~2690	2900~3500
MIMO 1								
Peak Gain (dBi) *	2.45	2.35	1.10	2.01	2.07	1.64	0.28	0.36
Average Gain (dBi) *	-2.33	-2.76	-3.99	-2.29	-2.42	-2.60	-5.00	-5.52
Efficiency (%)*	58.64	53.04	40.41	59.15	57.38	55.26	31.79	31.40
Return loss (dB) *	<-6							
MIMO 2								
Peak Gain (dBi) *	1.98	1.39	0.60	1.57	1.84	1.80	-2.54	-5.16
Average Gain (dBi) *	-2.41	-2.13	-2.94	-2.35	-2.46	-2.49	-8.06	-11.41
Efficiency (%) *	58.17	61.36	51.05	58.43	56.87	56.43	15.78	9.25
Return loss (dB) *	<-6							
Polarization	Linear							
Impedance	50Ω							
Cable	3m CFD-200 standard, fully customizable							
Connector	SMA Male Straight, fully customizable							

2.4GHz/5GHz MIMO		
Frequency (GHz)	2.4~2.5	5.15~5.85
MIMO 1		
Peak Gain (dBi) *	2.46	3.61
Average Gain (dBi) *	-3.24	-4.55
Efficiency (%)*	47.46	35.17
Return loss (dB) *	<-10	
MIMO 2		
Peak Gain (dBi) *	2.61	3.17
Average Gain (dBi) *	-3.12	-4.66
Efficiency (%)*	48.81	34.32
Return loss (dB) *	<-10	
Polarization	Linear	
Impedance	50Ω	
Cable	3m CFD-200 standard, fully customizable	
Connector	RP-SMA Male Straight, fully customizable	

MECHANICAL	
Antenna Dimensions	Height 84.5mm x Diameter 143.2mm
Casing	Wonderloy PC-540 PC
Waterproof	IP67
Recommended Torque for Mounting	49N·m
Max Torque for Mounting	58.8N·m
Weight	1.16kg/1pcs
ENVIRONMENTAL	
Operation Temperature	-40°C to 85°C
Storage Temperature	-40°C to 90°C
Humidity	Non-condensing 65°C 95% RH

\* All measurements were conducted with 3m cable length

LTE BANDS				
Band Number	LTE / LTE-Advanced / WCDMA / HSPA / HSPA+ / TD-SCDMA			
	Uplink	Downlink	MIMO 1	MIMO 2
1	UL: 1920 to 1980	DL: 2110 to 2170	✓	✓
2	UL: 1850 to 1910	DL: 1930 to 1990	✓	✓
3	UL: 1710 to 1785	DL: 1805 to 1880	✓	✓
4	UL: 1710 to 1755	DL: 2110 to 2155	✓	✓
5	UL: 824 to 849	DL: 869 to 894	✓	✓
7	UL: 2500 to 2570	DL: 2620 to 2690	✓	✓
8	UL: 880 to 915	DL: 925 to 960	✓	✓
9	UL: 1749.9 to 1784.9	DL: 1844.9 to 1879.9	✓	✓
11	UL: 1427.9 to 1447.9	DL: 1475.9 to 1495.9	✗	✗
12	UL: 699 to 716	DL: 729 to 746	✓	✓
13	UL: 777 to 787	DL: 746 to 756	✓	✓
14	UL: 788 to 798	DL: 758 to 768	✓	✓
17	UL: 704 to 716	DL: 734 to 746 (LTE only)	✓	✓
18	UL: 815 to 830	DL: 860 to 875 (LTE only)	✓	✓
19	UL: 830 to 845	DL: 875 to 890	✓	✓
20	UL: 832 to 862	DL: 791 to 821	✓	✓
21	UL: 1447.9 to 1462.9	DL: 1495.9 to 1510.9	✗	✗
22	UL: 3410 to 3490	DL: 3510 to 3590	✗	✗
23	UL: 2000 to 2020	DL: 2180 to 2200 (LTE only)	✓	✓
24	UL: 1625.5 to 1660.5	DL: 1525 to 1559 (LTE only)	✓	✓
25	UL: 1850 to 1915	DL: 1930 to 1995	✓	✓
26	UL: 814 to 849	DL: 859 to 894	✓	✓
27	UL: 807 to 824	DL: 852 to 869 (LTE only)	✓	✓
28	UL: 703 to 748	DL: 758 to 803 (LTE only)	✓	✓
29	UL: -	DL: 717 to 728 (LTE only)	✓	✓
30	UL: 2305 to 2315	DL: 2350 to 2360 (LTE only)	✓	✓
31	UL: 452.5 to 457.5	DL: 462.5 to 467.5 (LTE only)	✗	✗
32	UL: -	DL: 1452 - 1496	✗	✗
35		1850 to 1910	✓	✓
38		2570 to 2620	✓	✗
39		1880 to 1920	✓	✓
40		2300 to 2400	✓	✗
41		2496 to 2690	✓	✗
42		3400 to 3600	✓	✗
43		3600 to 3800	✗	✗

### 3. LTE MIMO

#### 3.1. LTE MIMO1 and MIMO2 Characteristics

##### 3.1.1. Return Loss

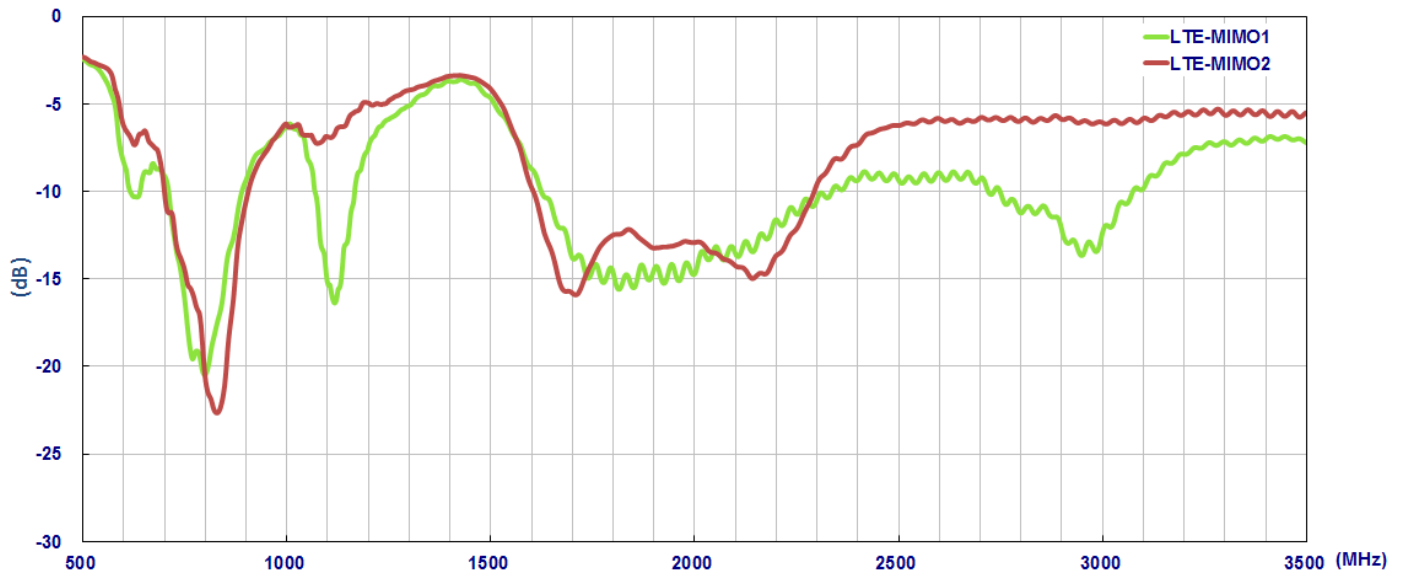

##### 3.1.2. Maximum Gain

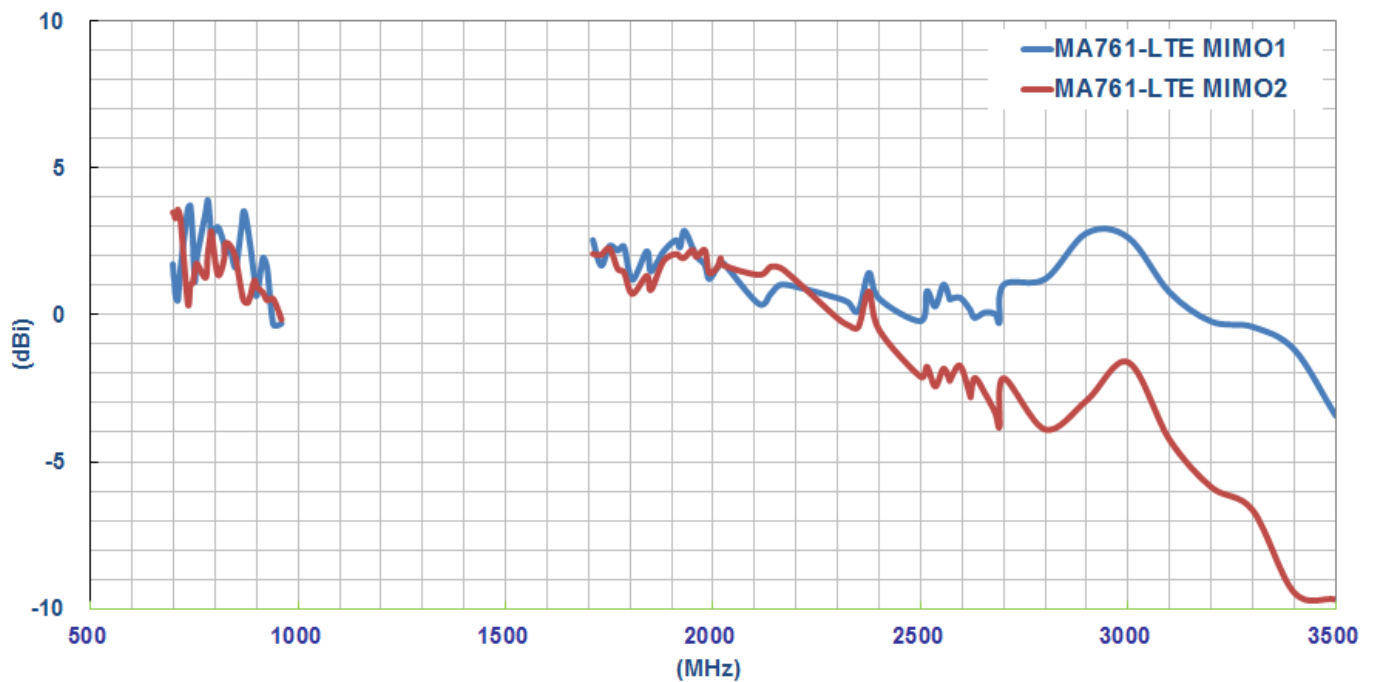

### 3.1.3. Average Gain

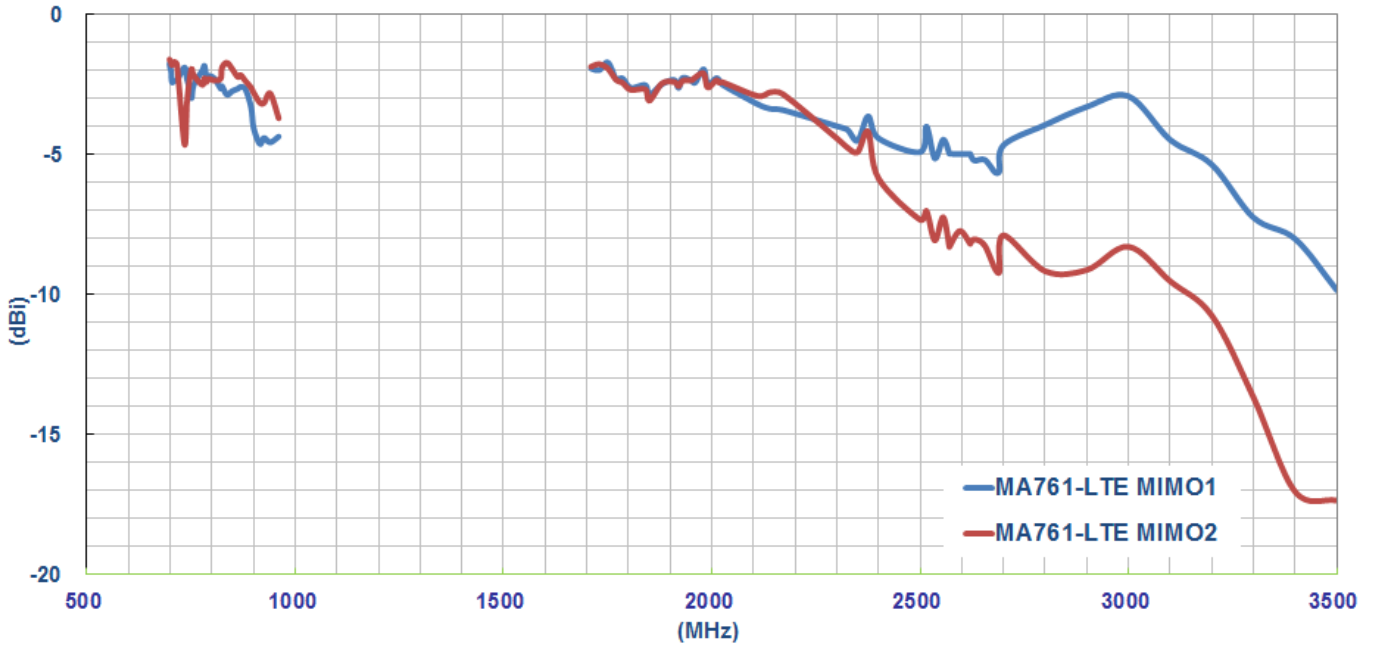

### 3.1.4. Efficiency

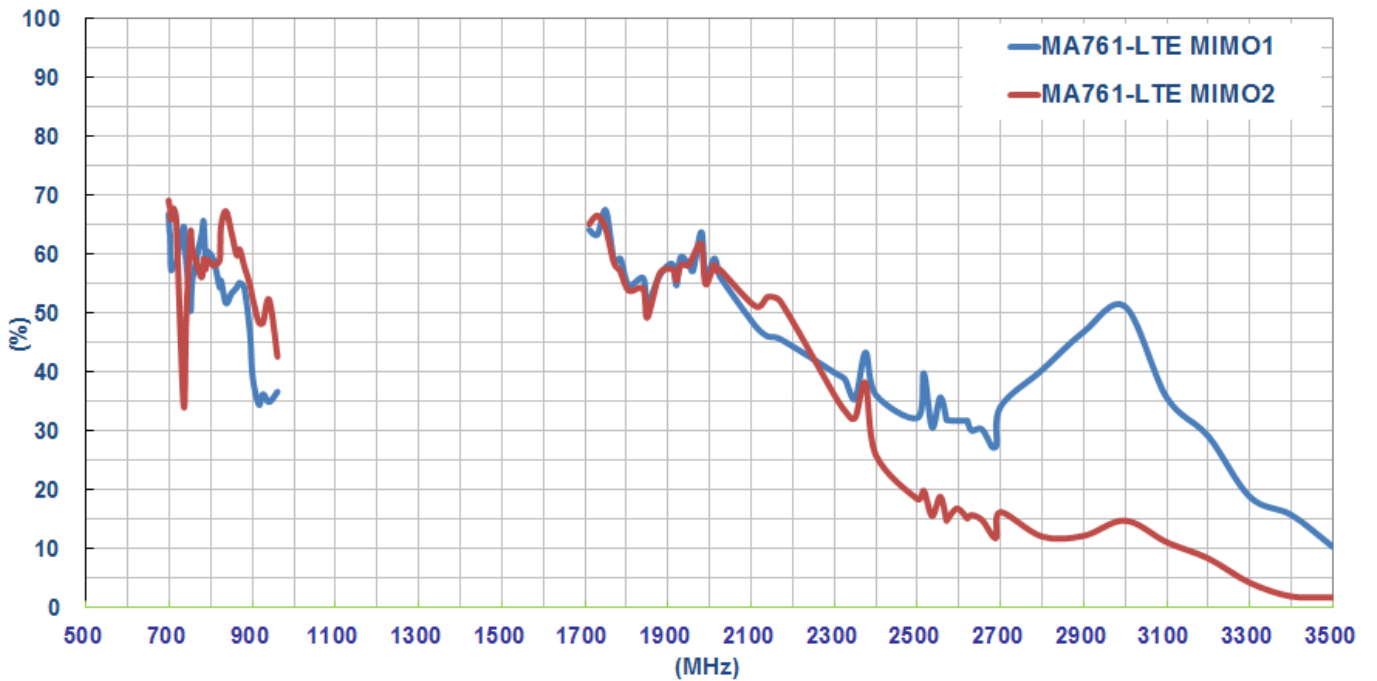

### 3.2. Radiation Pattern

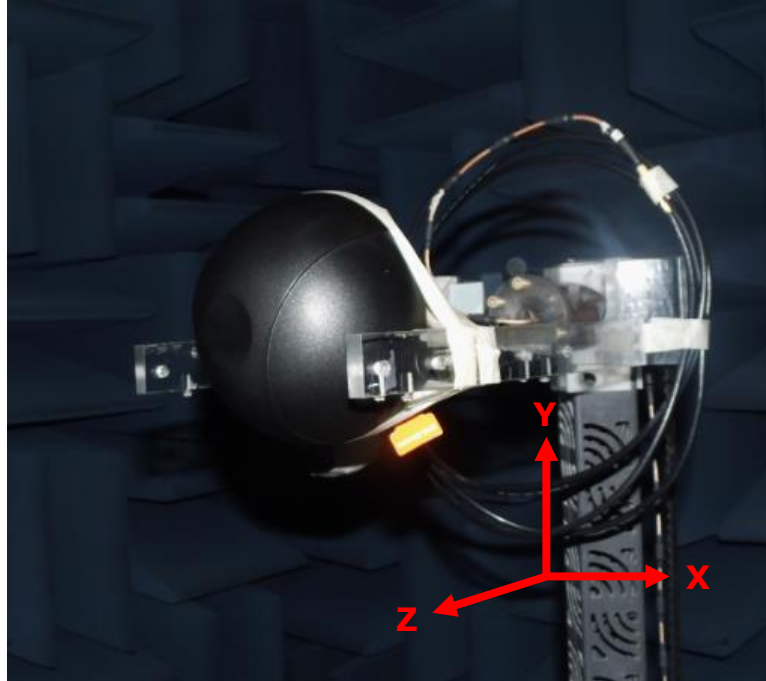



### 3.2.1. LTE MIMO1 Radiation Pattern

XY Plane

XZ Plane

YZ Plane

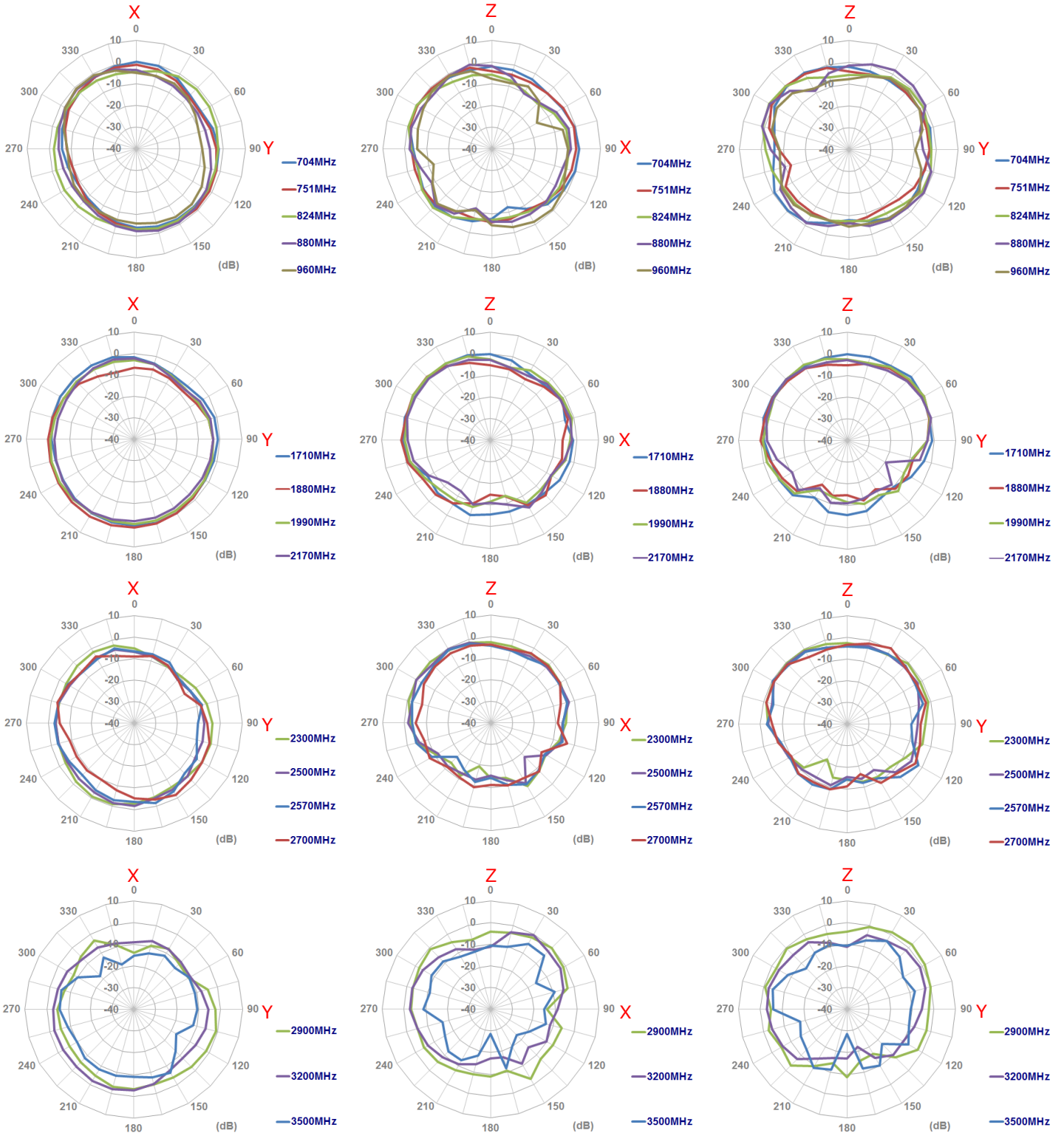

### 3.2.2. LTE MIMO2 Radiation Pattern

XY Plane

XZ Plane

YZ Plane

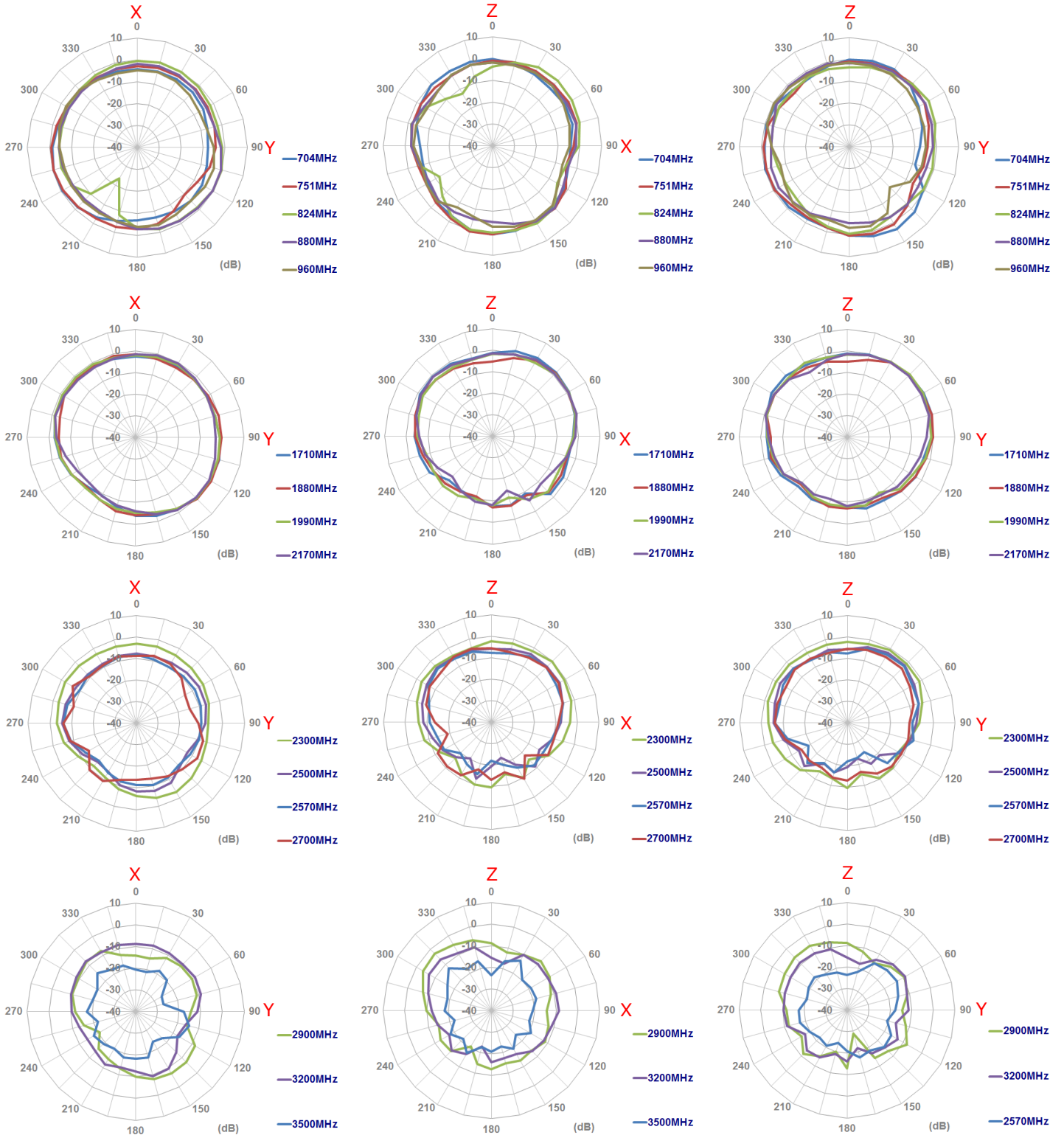

## 4. 2.4/5GHz MIMO

### 4.1. 2.4/5GHz MIMO1 and MIMO2 Characteristics

#### 4.1.1. Return Loss

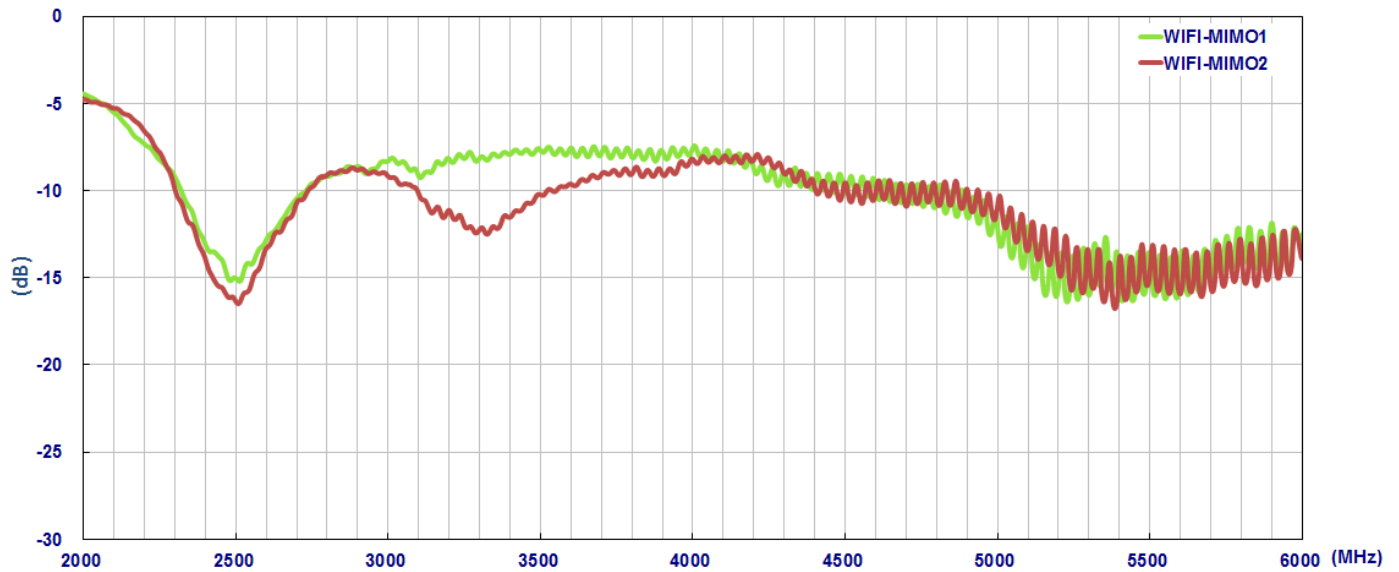

#### 4.1.2. Maximum Gain

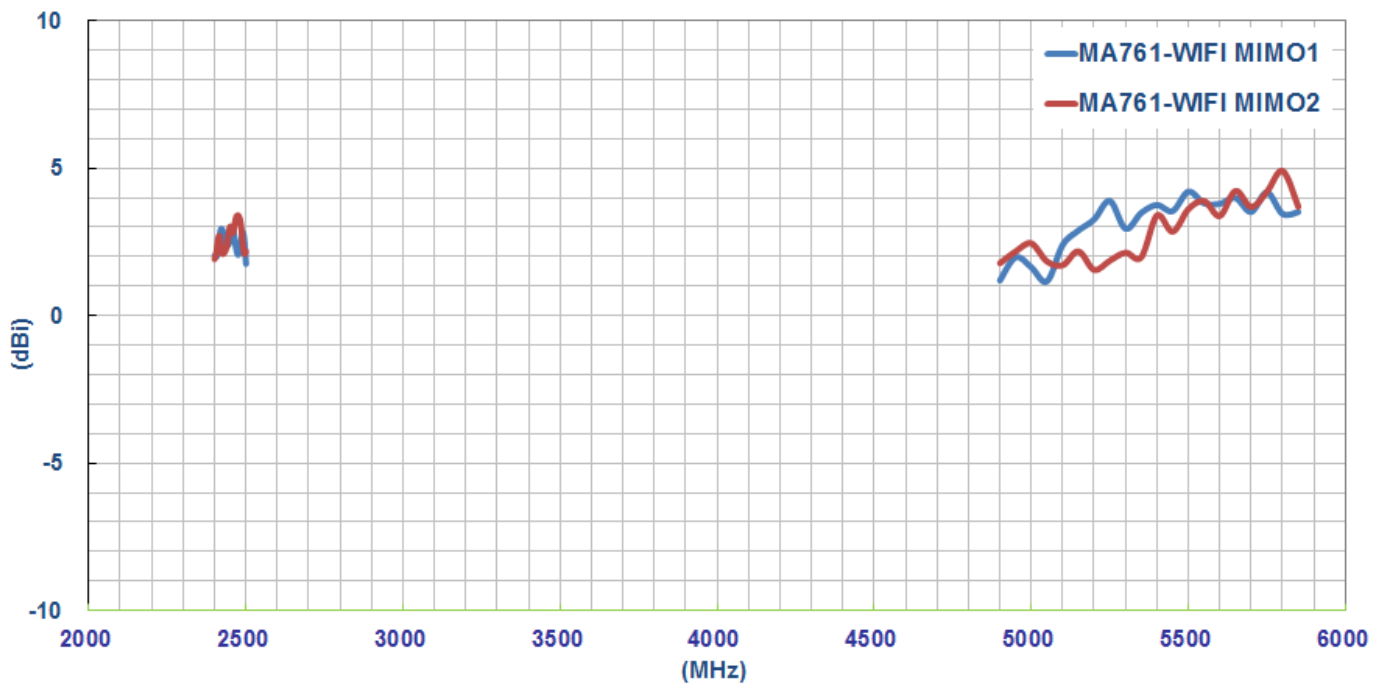

### 4.1.3. Average Gain

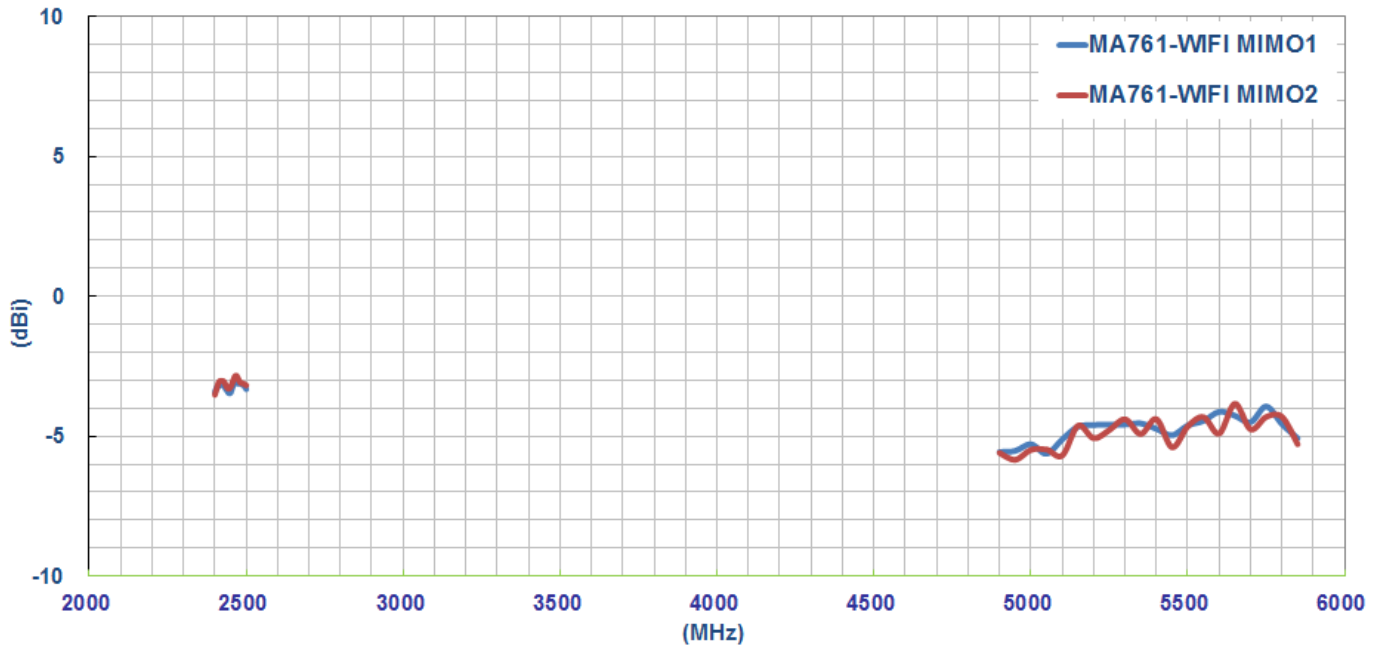

### 4.1.4. Efficiency

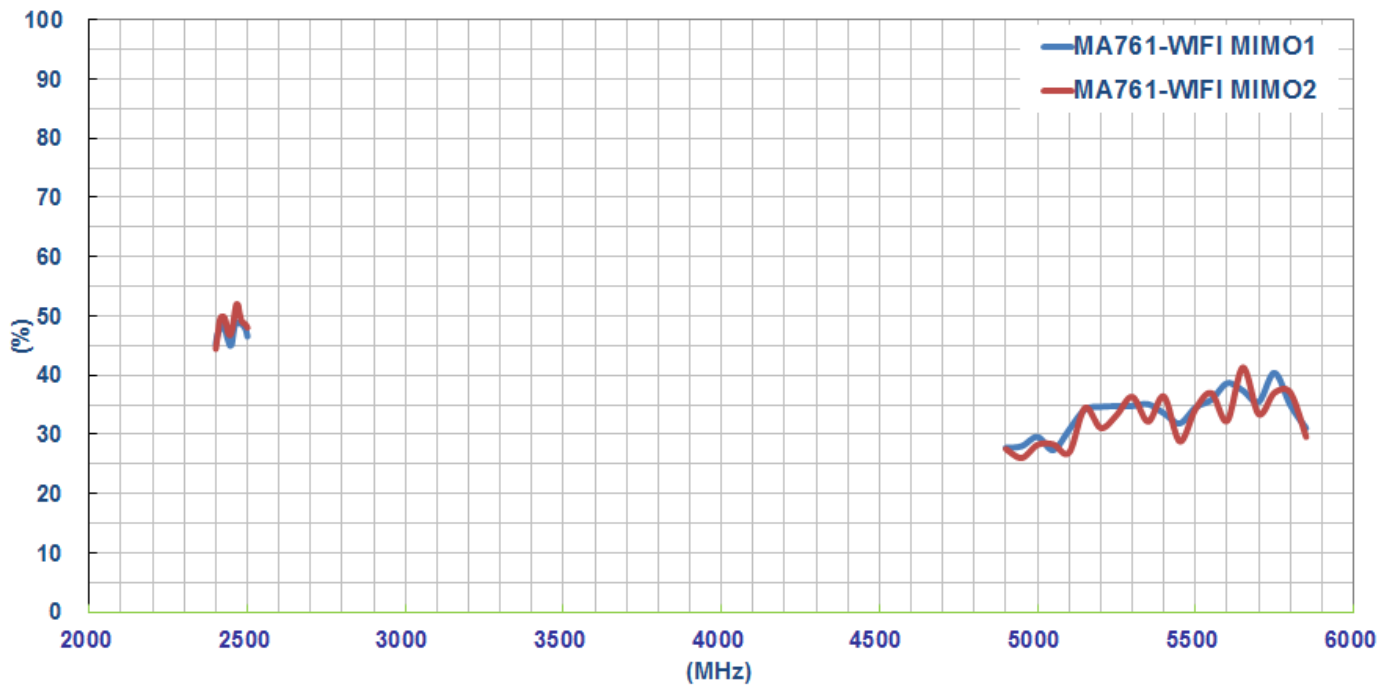

## 4.2. Radiation Patterns

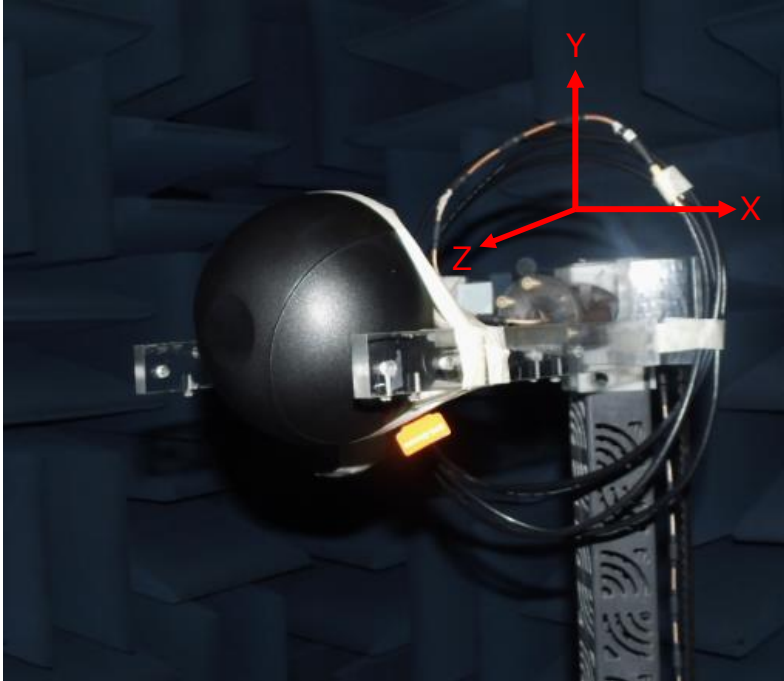

### 4.2.1. 2.4/5GHz MIMO1 Radiation pattern

XY Plane

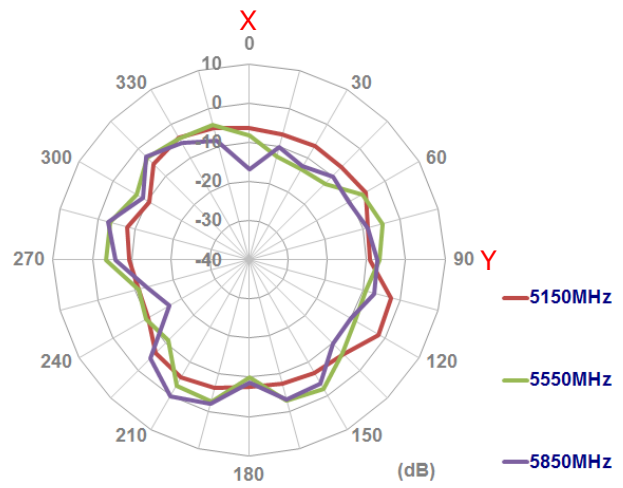
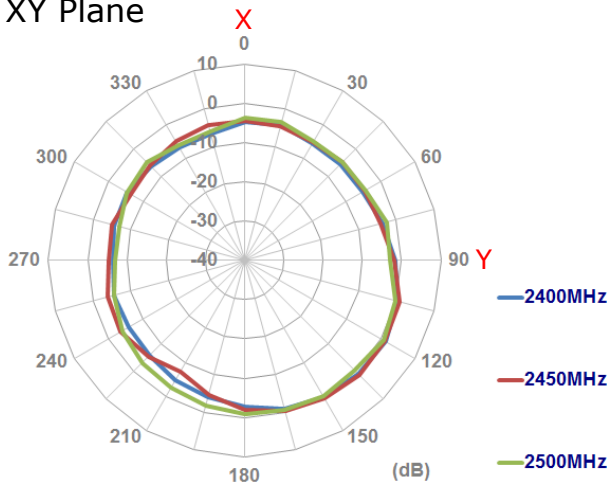

XZ Plane

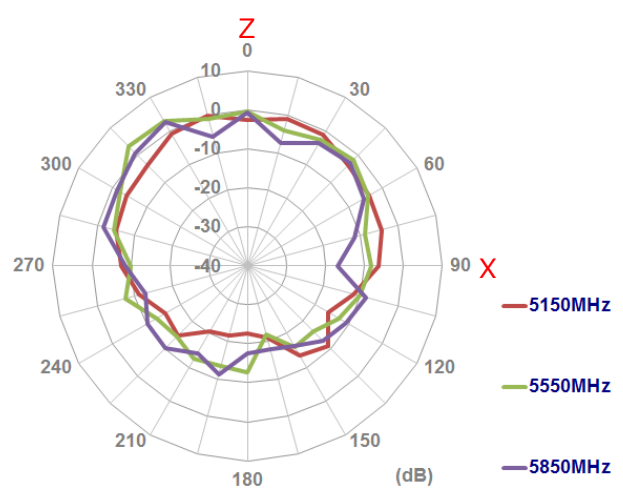
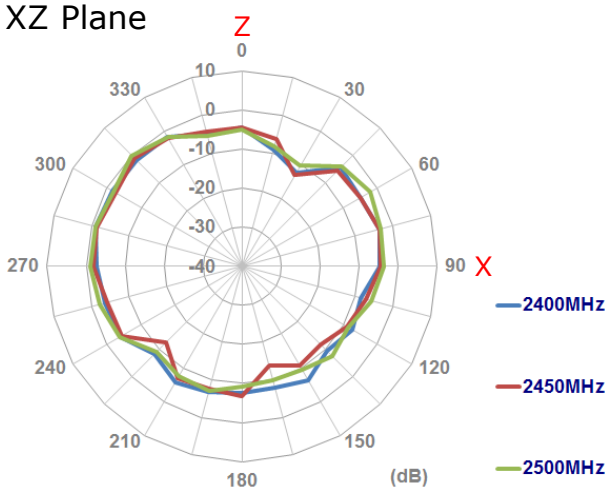

YZ Plane

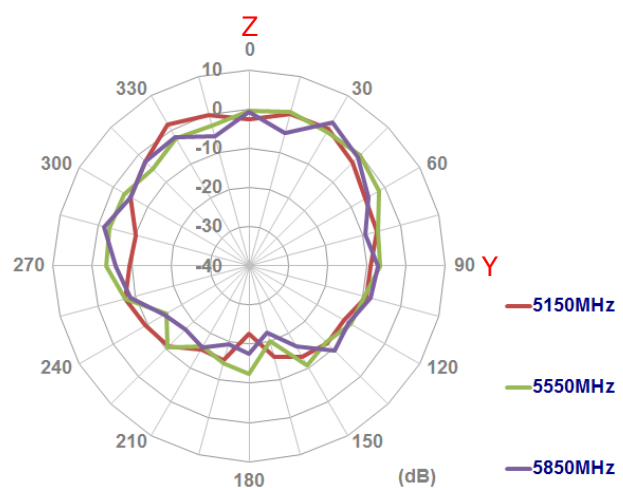
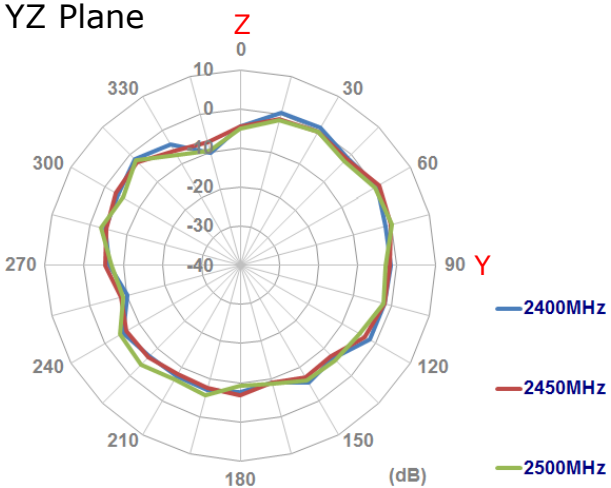



### 4.2.2. 2.4/5GHz MIMO2 Radiation pattern

XY Plane

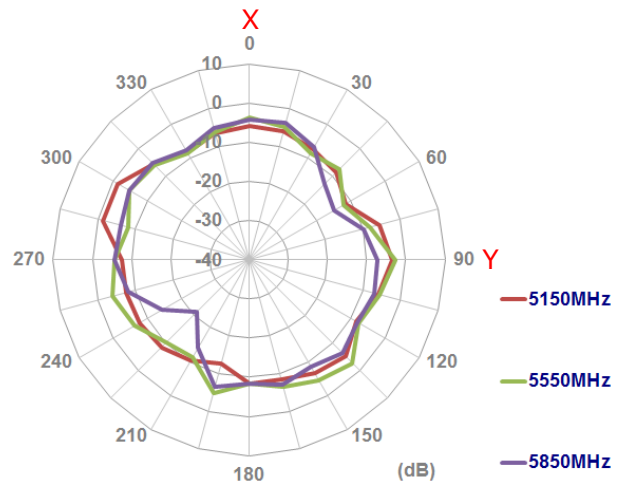
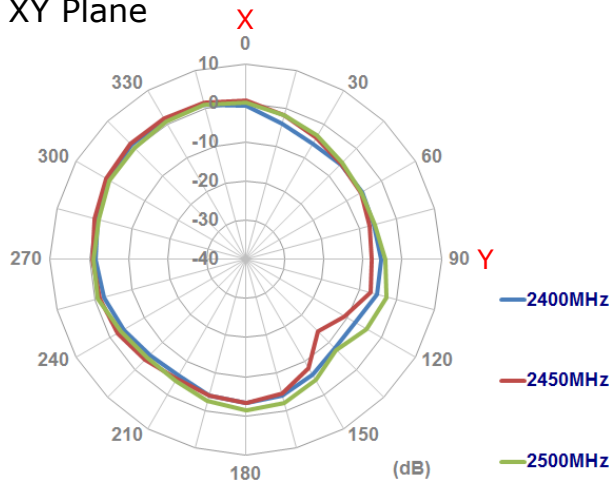

XZ Plane

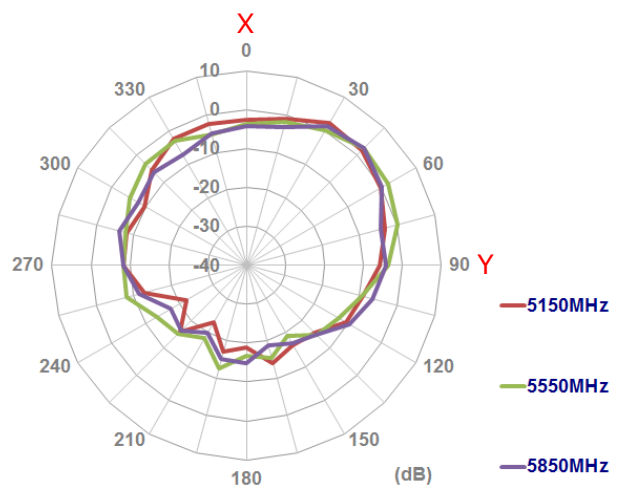
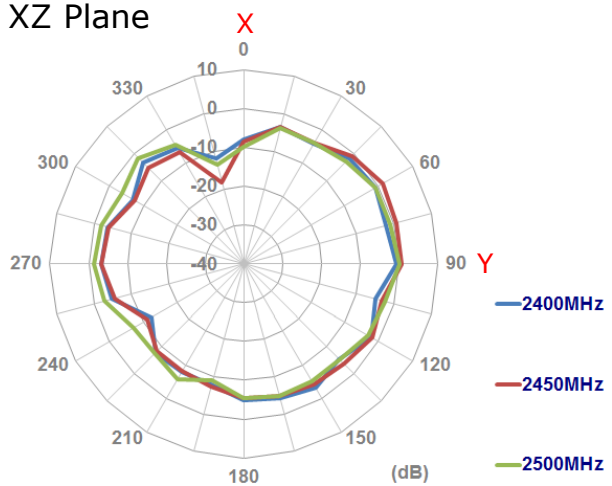

YZ Plane

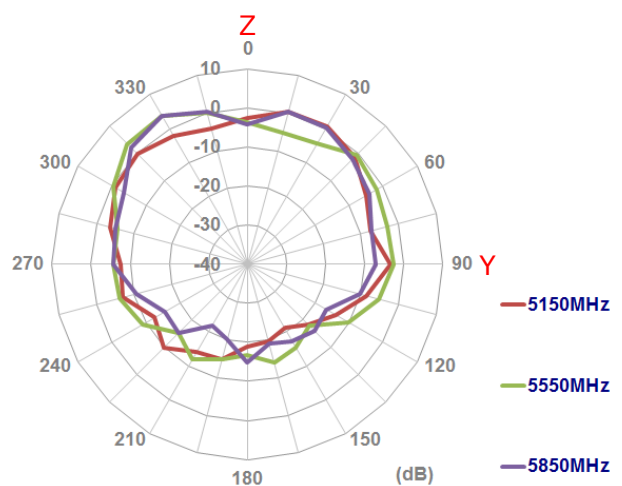
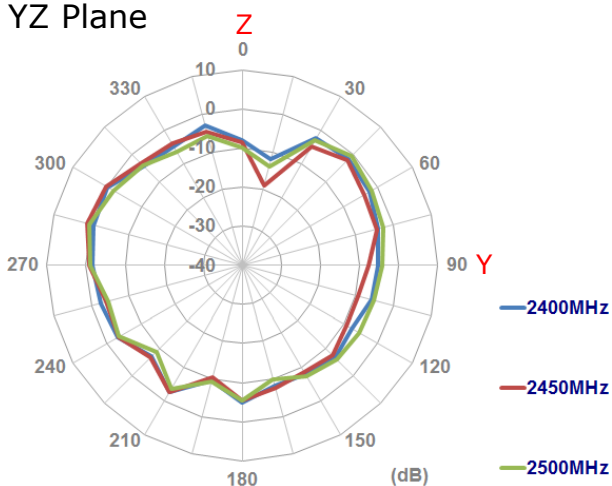

## 5. Drawing

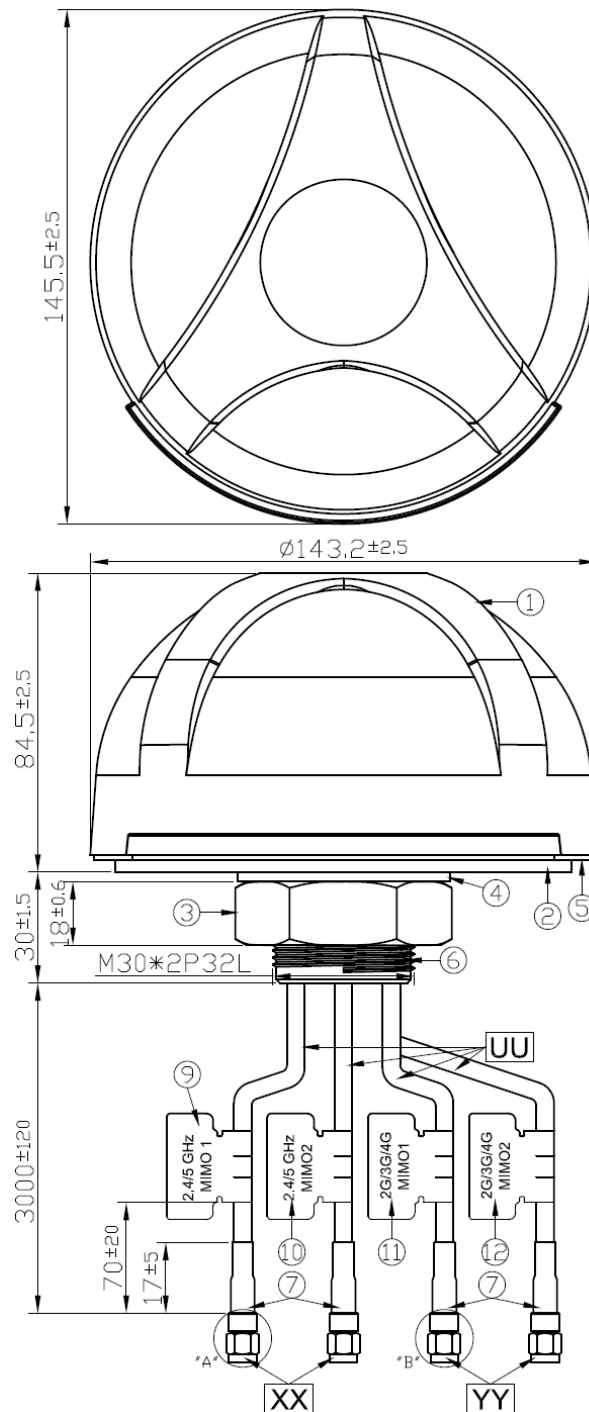



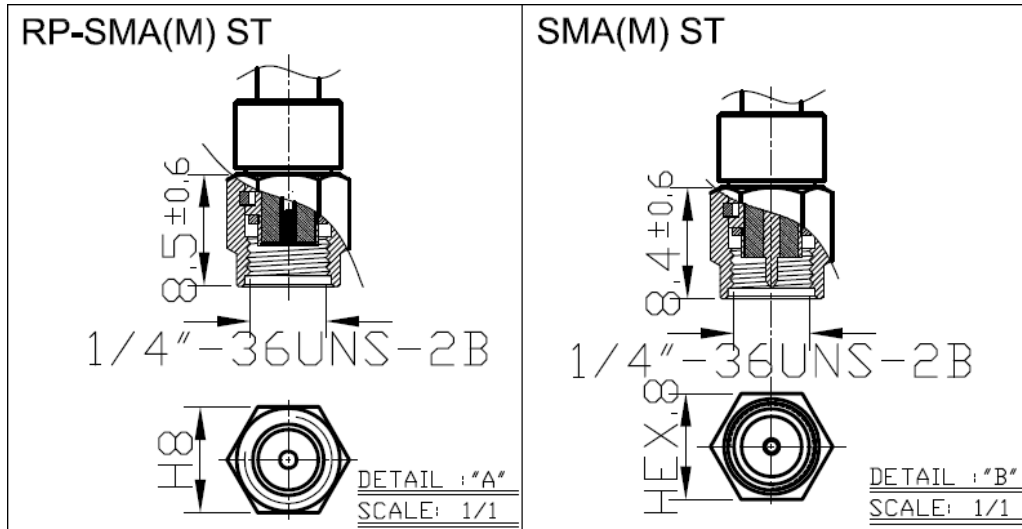

	Name	P/N	Material	Finish	QTY
1	Housing	000111I000015A	PC 540	Black	1
2	Closed Cell Foam	001011F030015A	CR4305	White LIner	1
3	M30 Nut	000411F000015A	Steel AISI 1215	Ni Plated	1
4	Washer	000411F010015A	Steel AISI 1215	Ni Plated	1
5	Waterproof Rubber	000711F000015A	Sillcon Rubber	Black	1
6	M30x 2 Thread 32L	000311F000015A	Zinc Alloy	Ni Plated	1
7	Heat Shrink Tube	001311F010015A	PE (CFD200)	Black	4
8	Rubber Stopper	000711F010015A	Sillcone Rubber	Black	1
9	2.4/5 GHz MIMO1 Label	001012L100015A	Coated Paper	DarkGreen	1
10	2.4/5 GHz MIMO2 Label	001012L110015A	Coated Paper	GreenYellow	1
11	2G/3G/4G MIMO1 Label	001012L080015A	Coated Paper	Gray	1
12	2G/3G/4G MIMO2 Label	001012L090015A	Coated Paper	White	1

	Name	P/N	Spec	Finish	QTY
UU	Cable Type	301412K000015A	CFD200	Black	4
XX	Connector Type	200212F000015A	RP-SMA(M) ST	Gold	2
YY	Connector Type	200212G010015A	SMA(M) ST	Gold	2

## 6. Installation

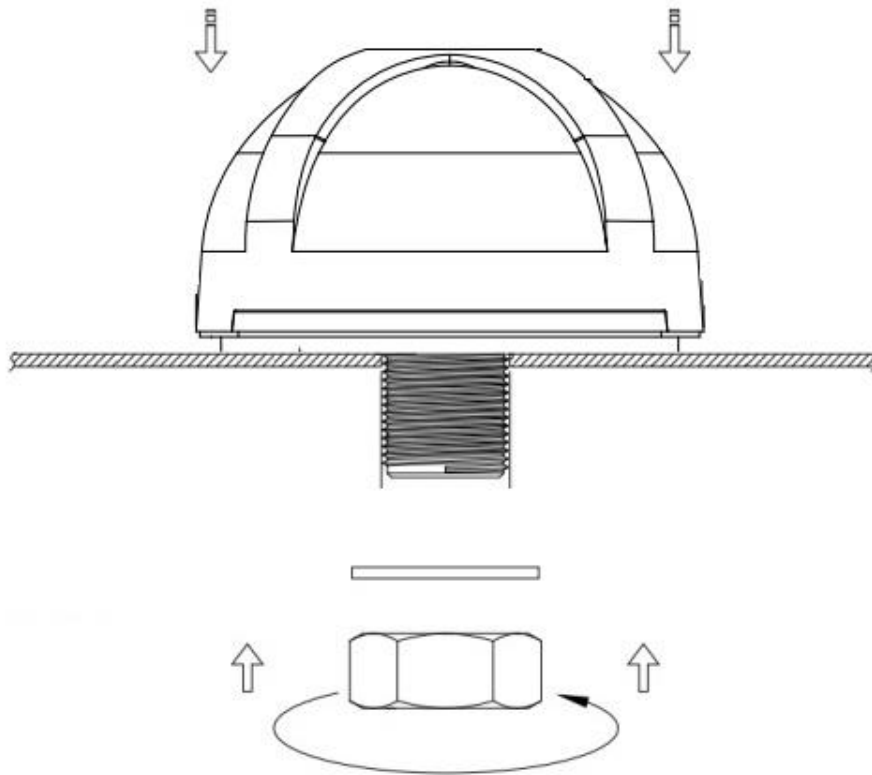

Recommended Torque for Mounting 49 N·m  
 Maximum Torque for Mounting 58.8 N·m

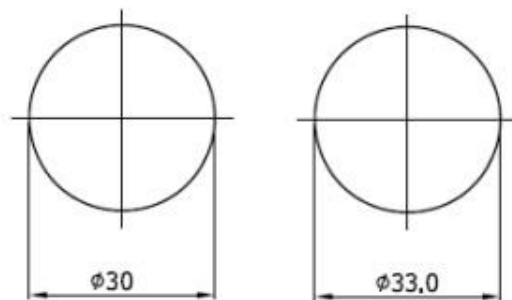

**Thread  
 Diameter**

**Recommended  
 Mounting Hole**

**Unit: mm**

## 7. Packaging

1 MA761.B.BICG.003 per box  
 Box Dimensions - 185\*170\*180 mm  
 Total Weight - 1.52Kg

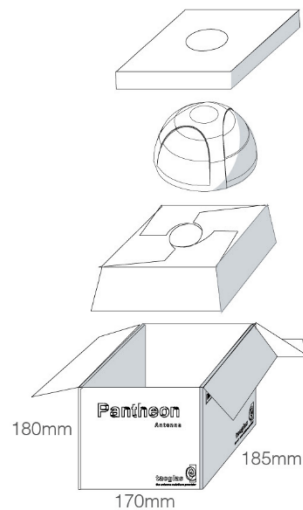

8 boxes per carton  
 Carton Dimensions - 380\*350\*380 mm  
 Weight - 13.3Kg

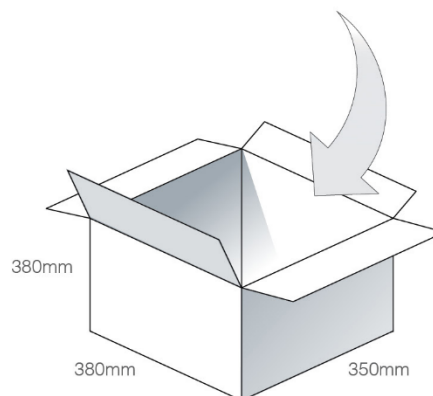

Pallet Dimensions 1100\*1100\*1290mm  
 24 Cartons per pallet  
 6 Cartons per layer  
 4 Layers

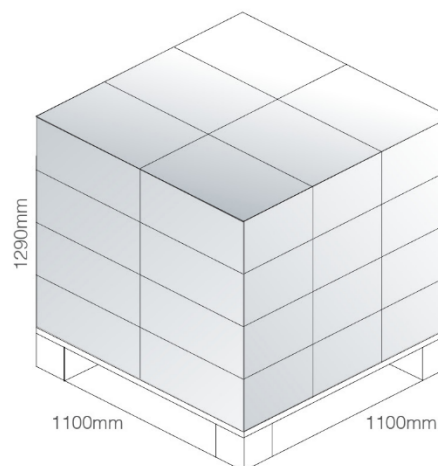

## 8. Application Note

### 8.1. LTE MIMO1 Antenna

#### 8.1.1. Return Loss

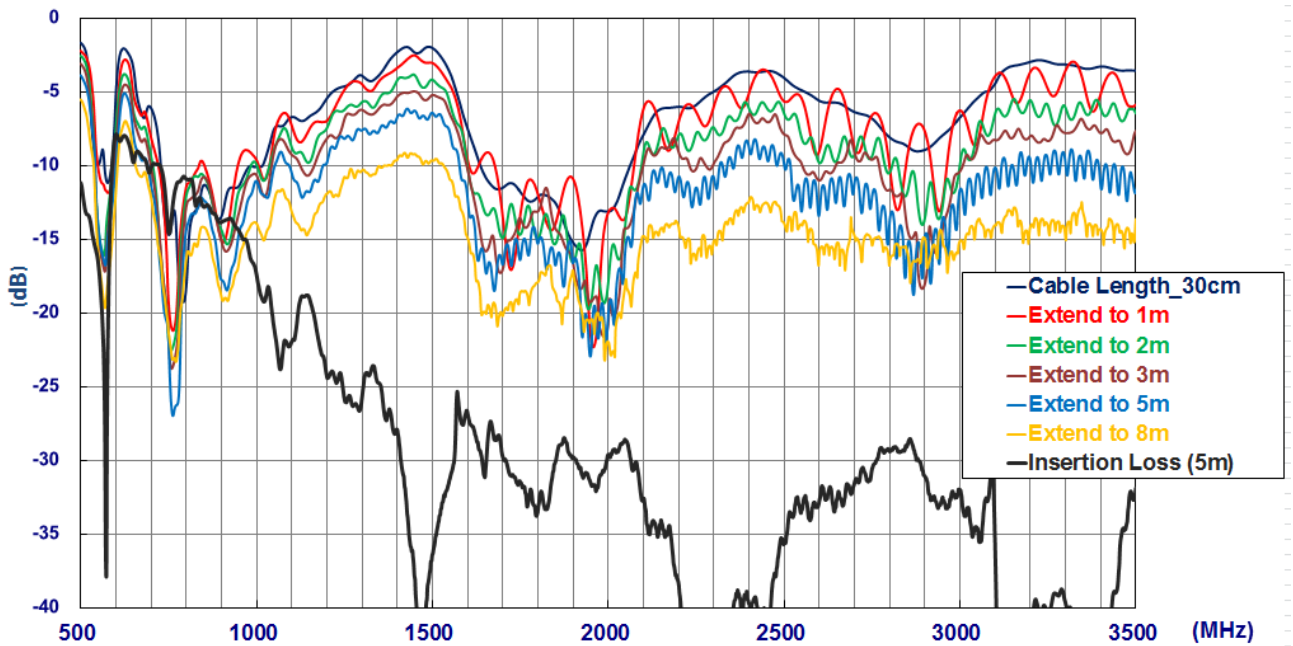

#### 8.1.2. Maximum Gain

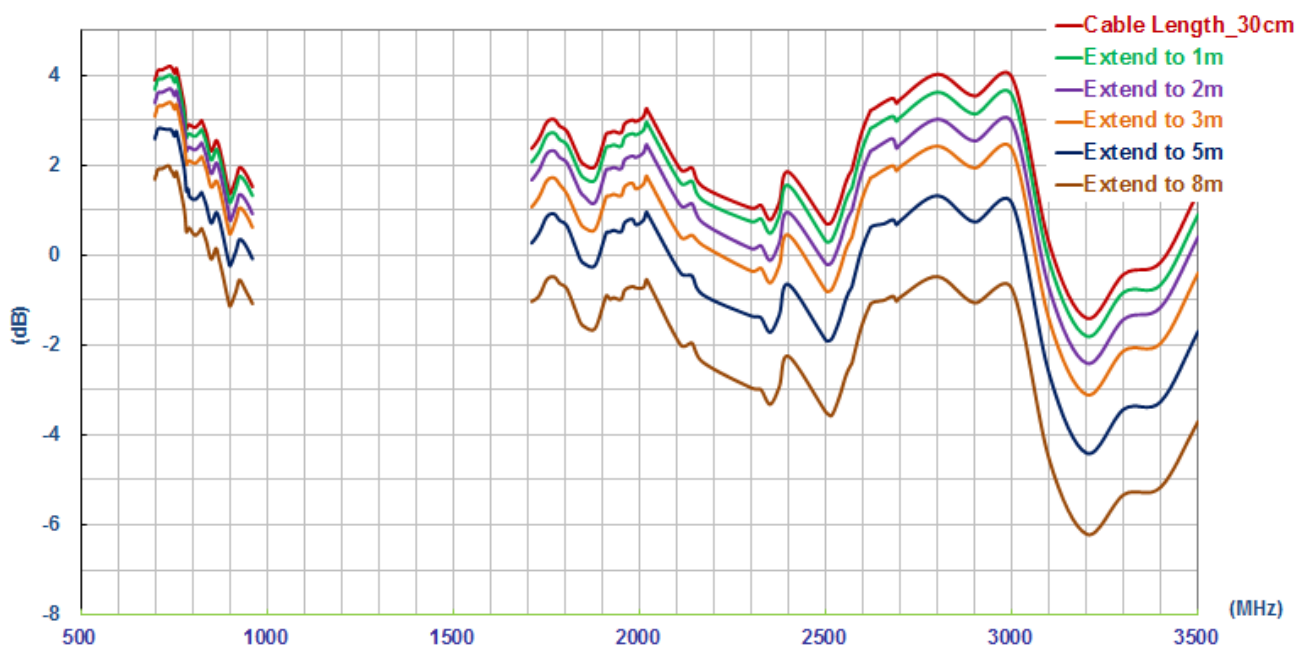

### 8.1.3. Average Gain

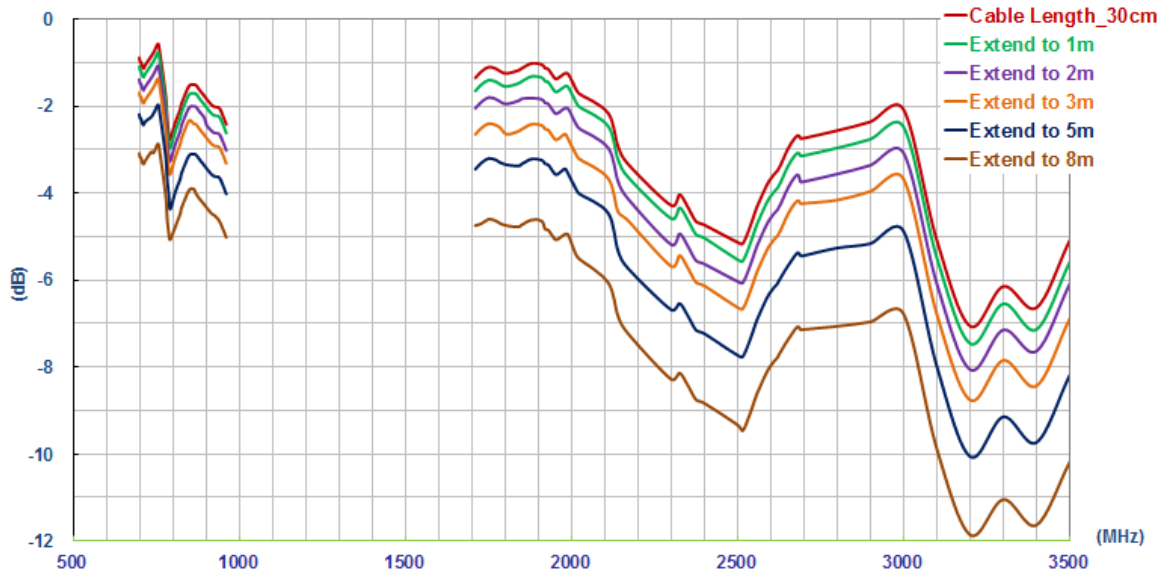

### 8.1.4. Efficiency

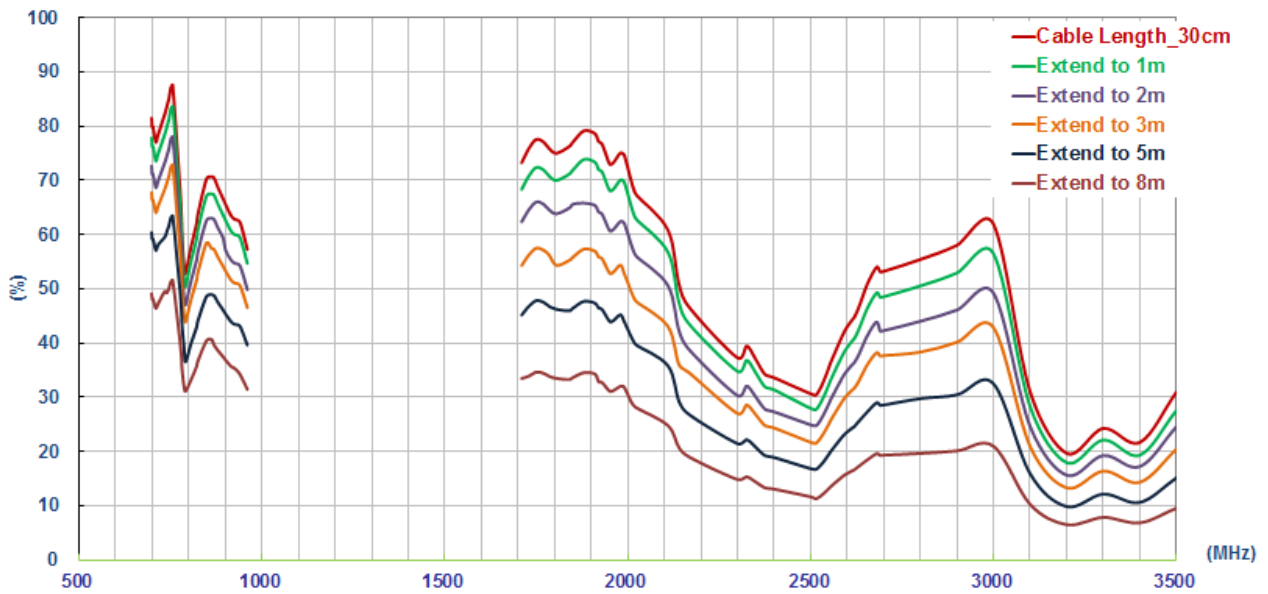

## 8.2. LTE MIMO2 Antenna

### 8.2.1. LTE MIMO2 Return Loss

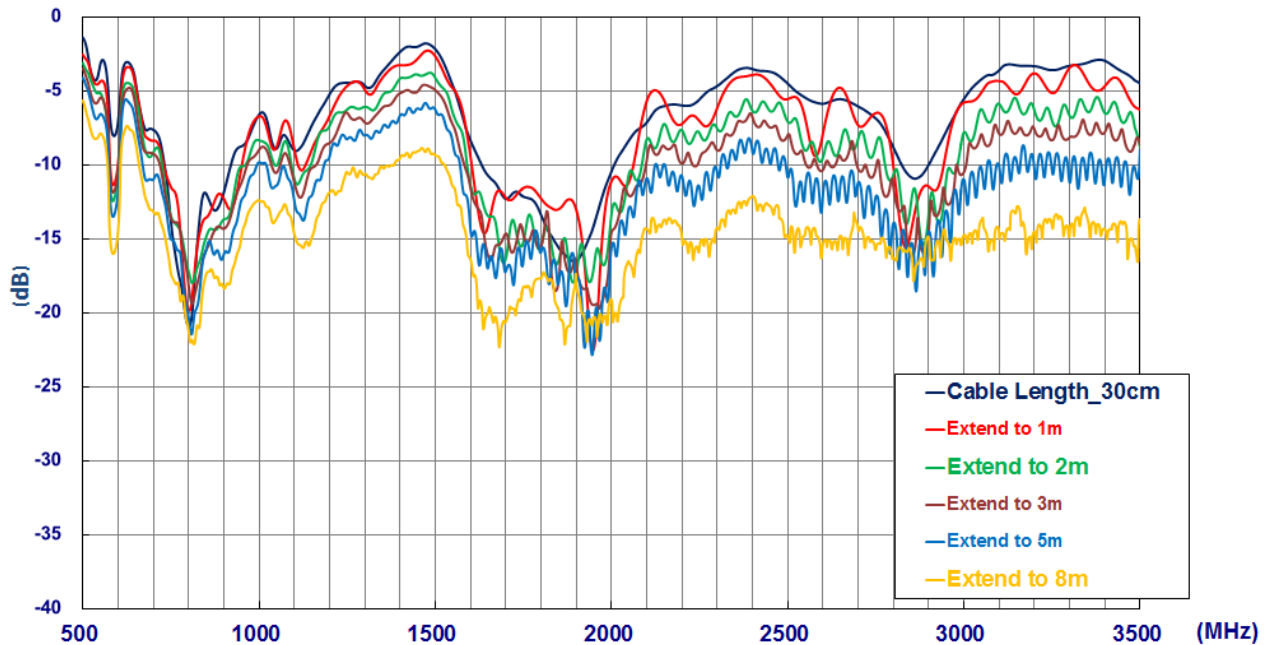

### 8.2.2. Maximum Gain

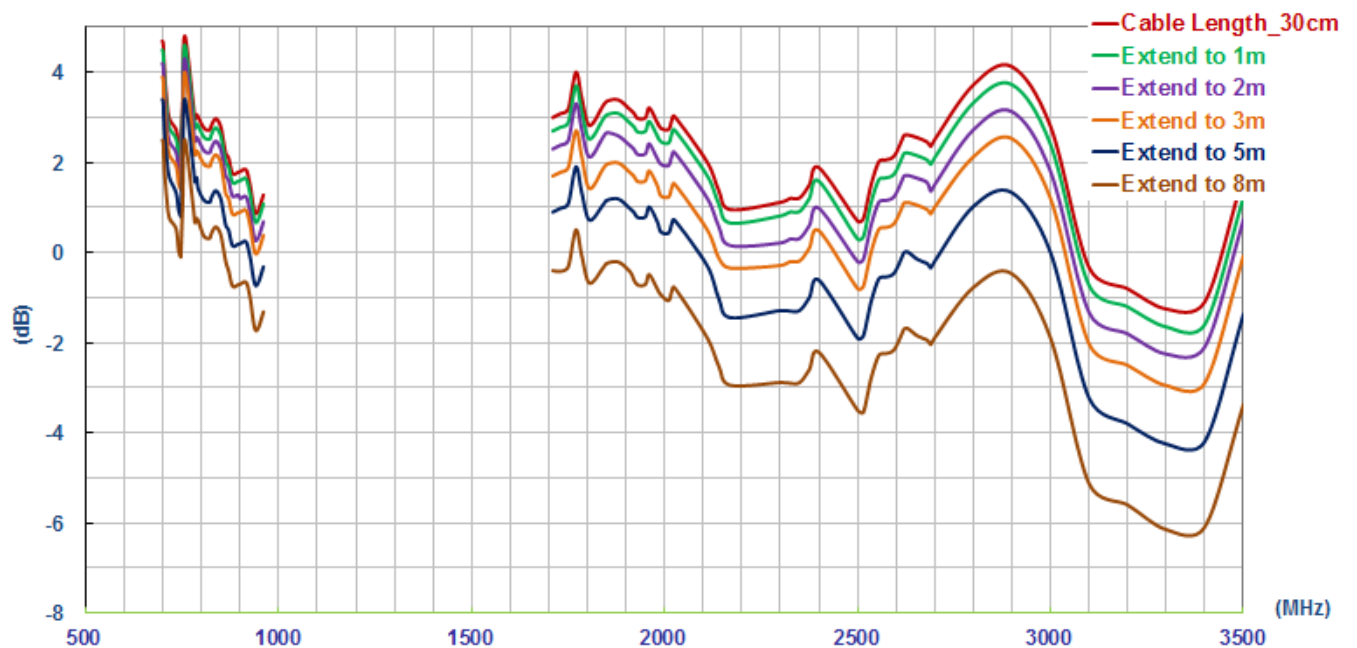

### 8.2.3. Average Gain

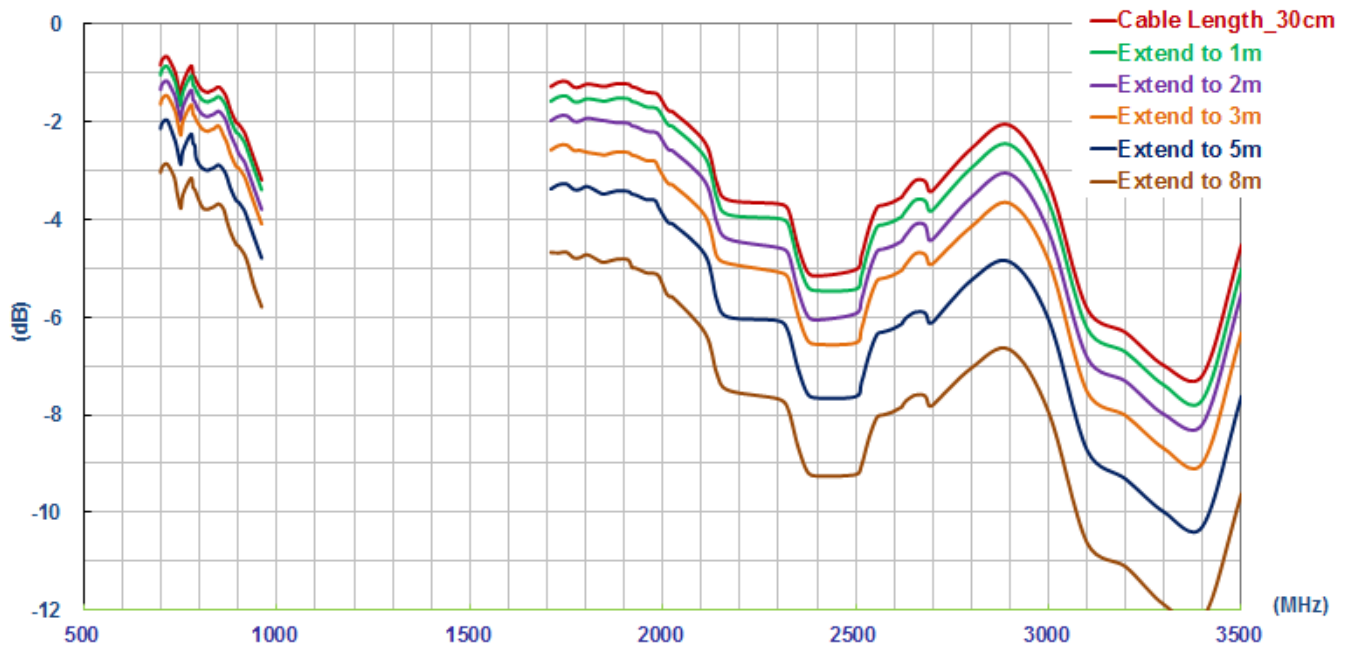

### 8.2.4. Efficiency

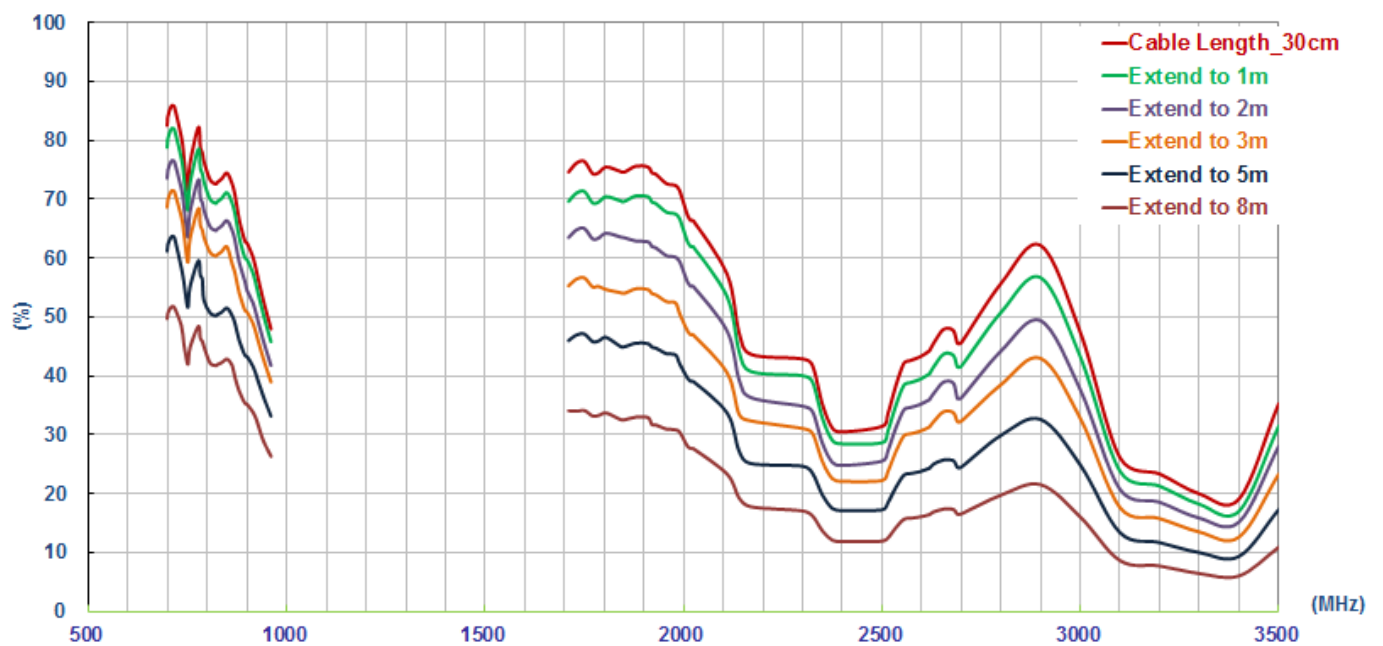



### 8.3. 2.4/5GHz MIMO1 Antenna

#### 8.3.1. Return Loss

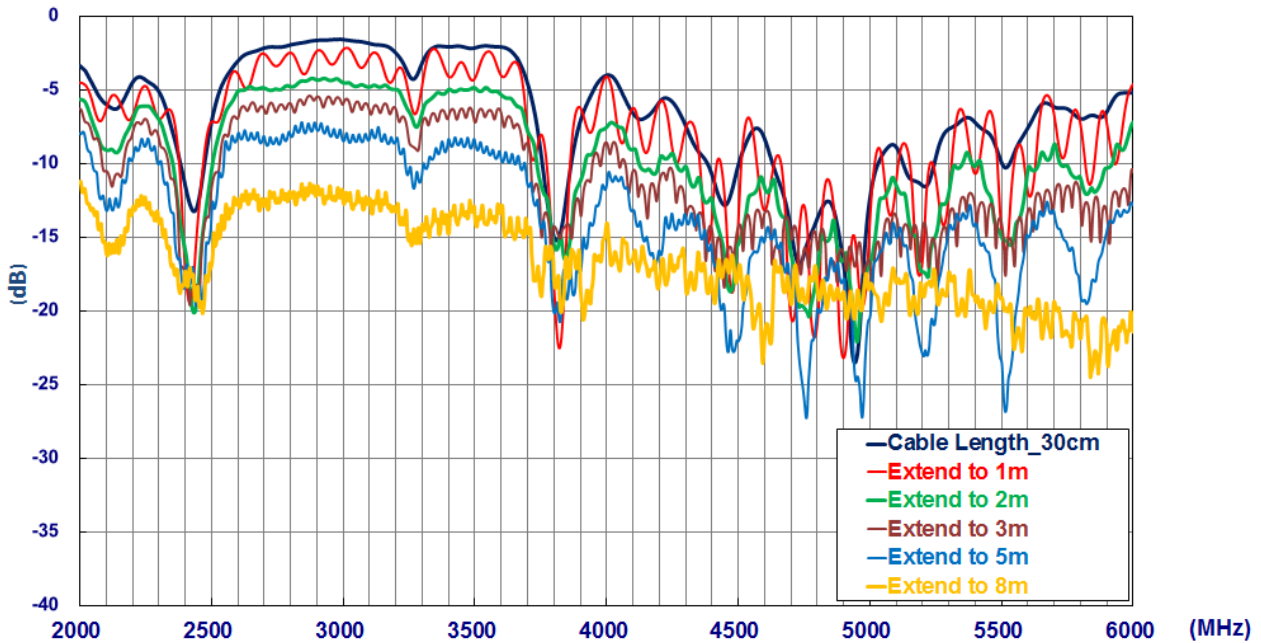

#### 8.3.2. Maximum Gain

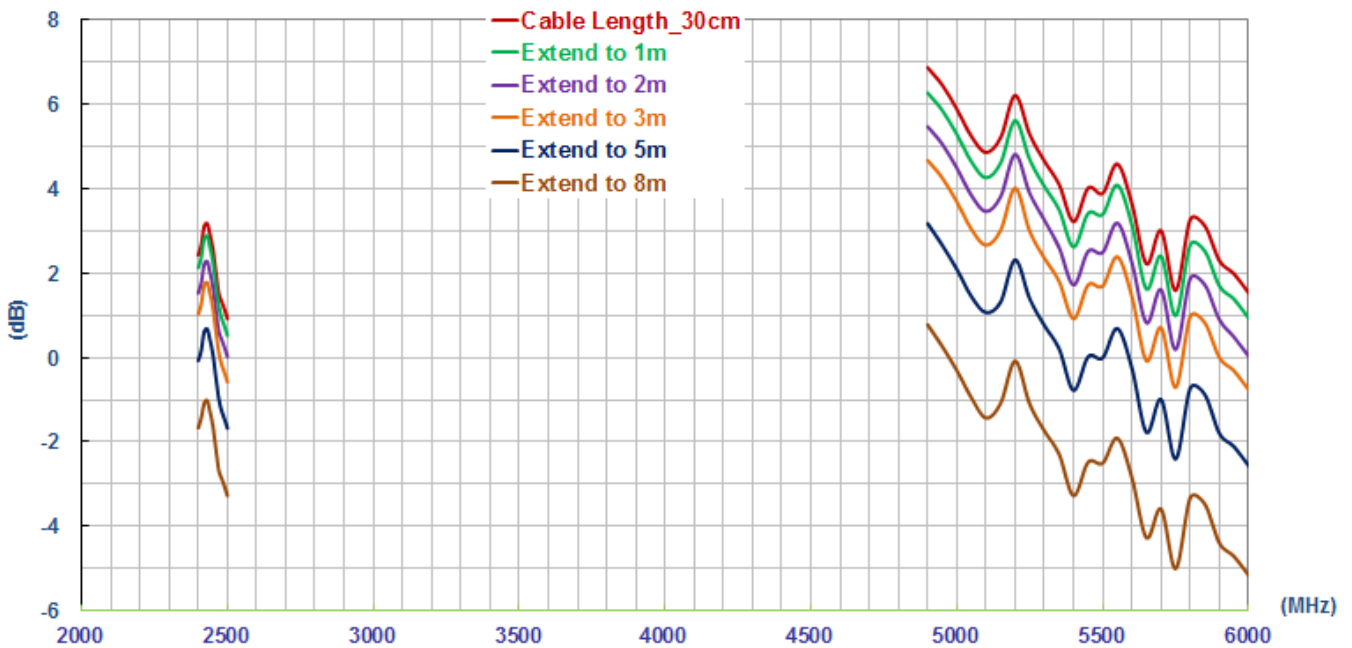



### 8.3.3. Average Gain

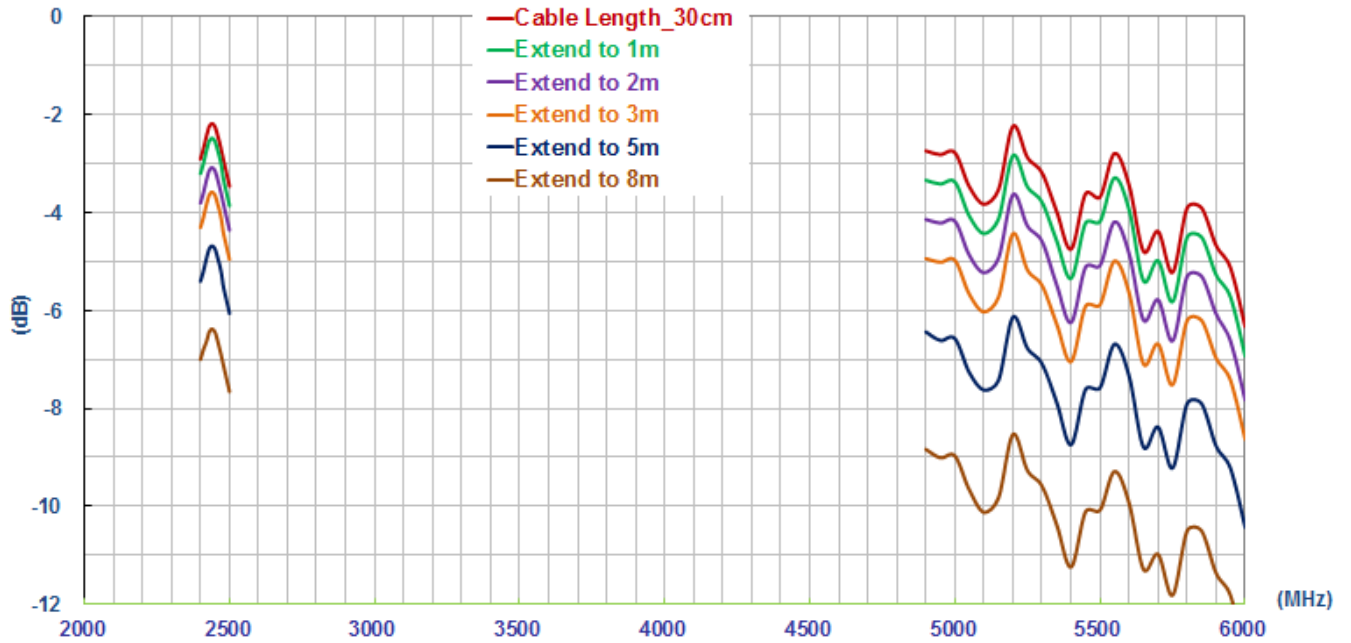

### 8.3.4. Efficiency

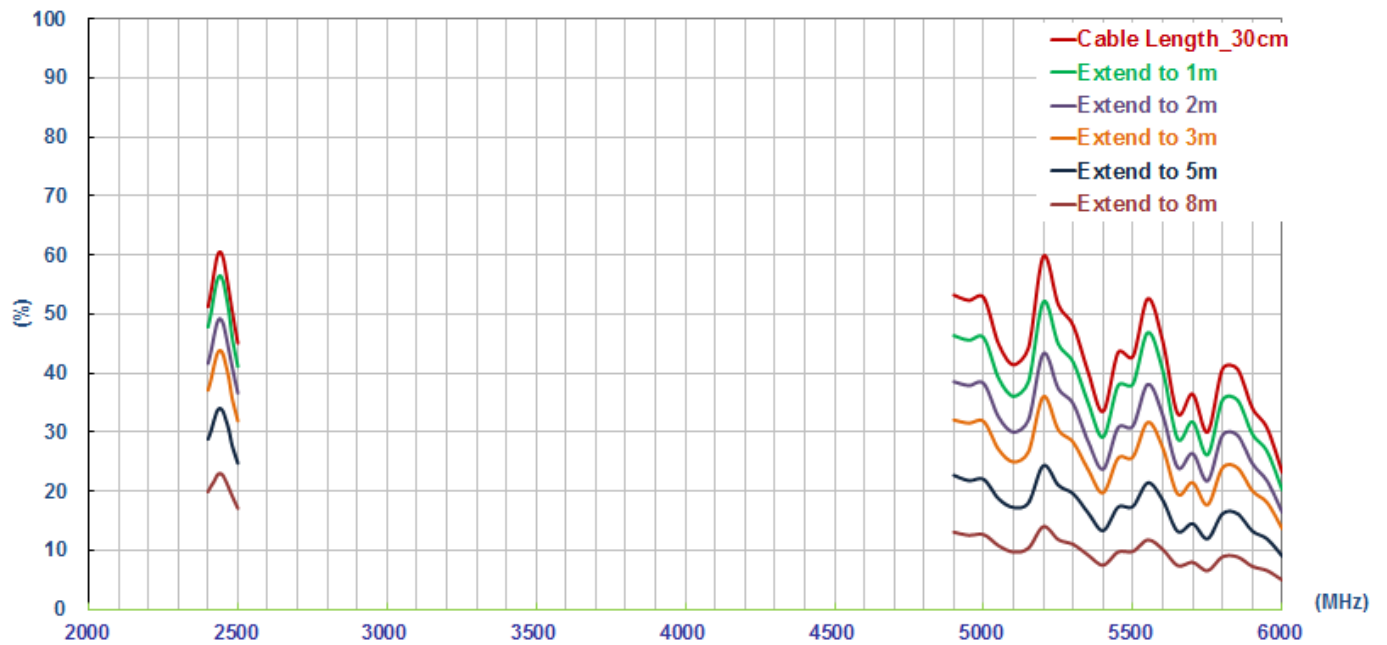

## 8.4. 2.4/5GHz MIMO2 Antenna

### 8.4.1. Return Loss

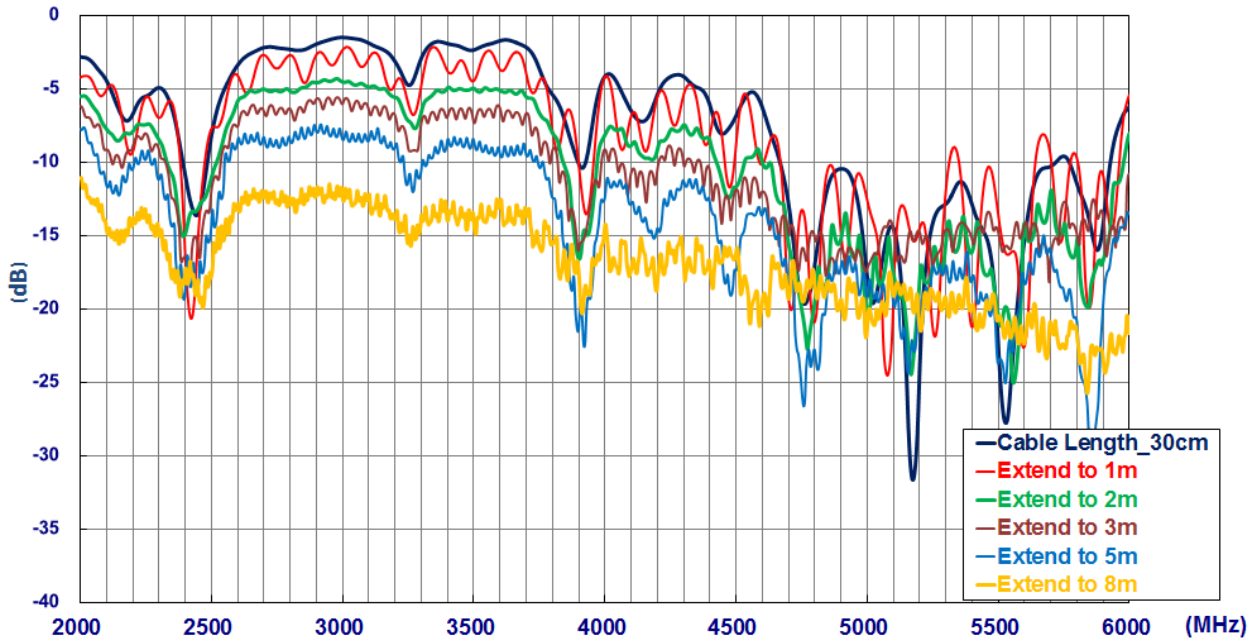

### 8.4.2. Maximum Gain

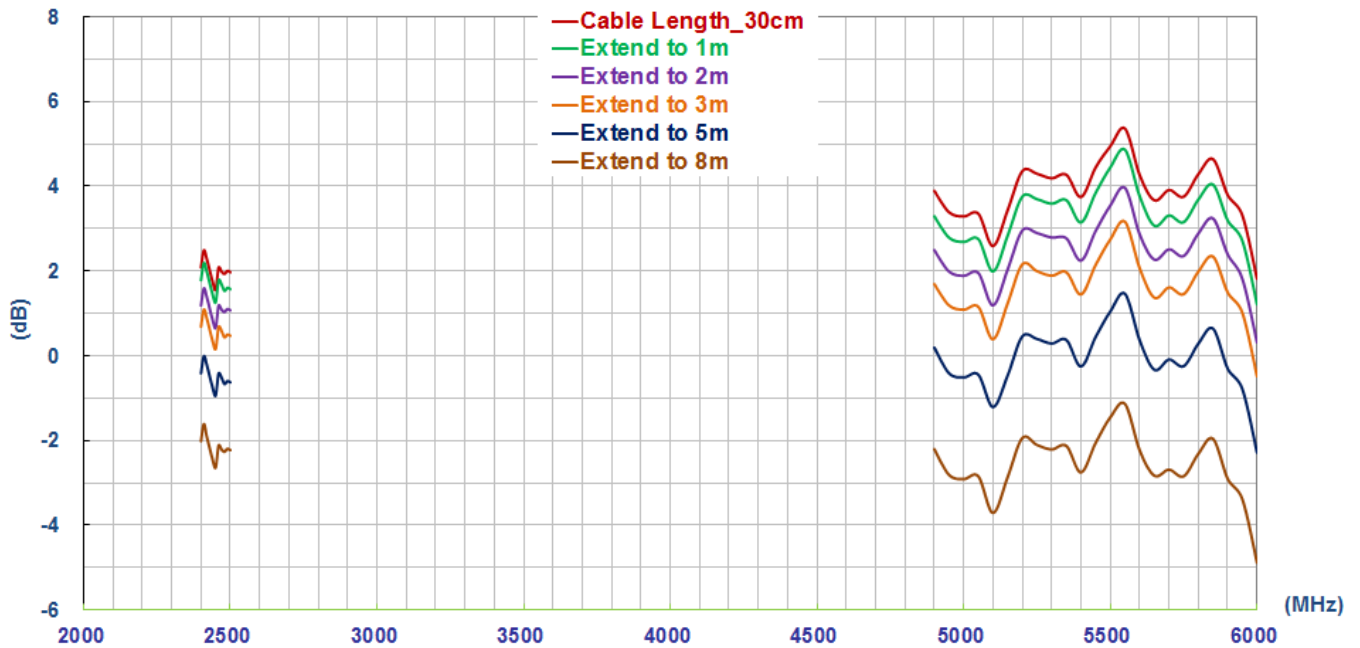

### 8.4.3. Average Gain

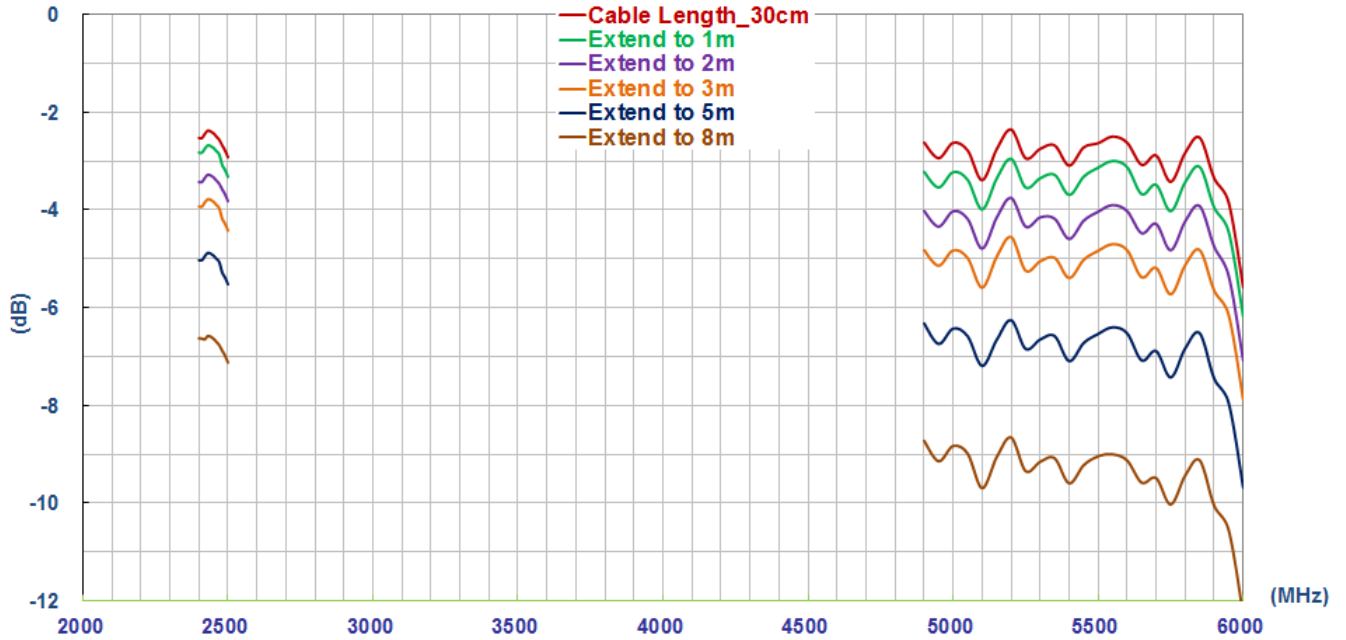

### 8.4.4. Efficiency

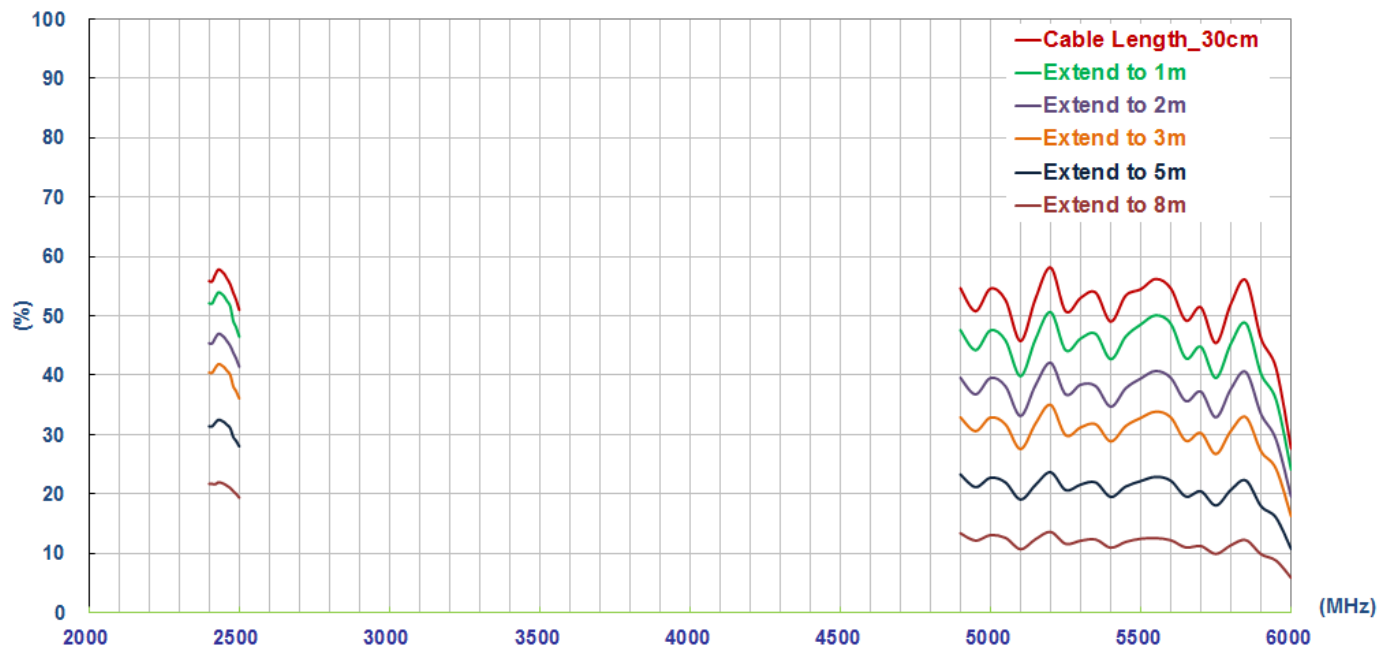

Taoglas makes no warranties based on the accuracy or completeness of the contents of this document and reserves the right to make changes to specifications and product descriptions at any time without notice. Taoglas reserves all rights to this document and the information contained herein.

Reproduction, use or disclosure to third parties without express permission is strictly prohibited.

Copyright © Taoglas Ltd.



Компания «ЭлектроПласт» предлагает заключение долгосрочных отношений при поставках импортных электронных компонентов на взаимовыгодных условиях!

Наши преимущества:

- Оперативные поставки широкого спектра электронных компонентов отечественного и импортного производства напрямую от производителей и с крупнейших мировых складов;
- Поставка более 17-ти миллионов наименований электронных компонентов;
- Поставка сложных, дефицитных, либо снятых с производства позиций;
- Оперативные сроки поставки под заказ (от 5 рабочих дней);
- Экспресс доставка в любую точку России;
- Техническая поддержка проекта, помощь в подборе аналогов, поставка прототипов;
- Система менеджмента качества сертифицирована по Международному стандарту ISO 9001;
- Лицензия ФСБ на осуществление работ с использованием сведений, составляющих государственную тайну;
- Поставка специализированных компонентов (Xilinx, Altera, Analog Devices, Intersil, Interpoint, Microsemi, Aeroflex, Peregrine, Syfer, Eurofarad, Texas Instrument, Miteq, Cobham, E2V, MA-COM, Hittite, Mini-Circuits, General Dynamics и др.);

Помимо этого, одним из направлений компании «ЭлектроПласт» является направление «Источники питания». Мы предлагаем Вам помощь Конструкторского отдела:

- Подбор оптимального решения, техническое обоснование при выборе компонента;
- Подбор аналогов;
- Консультации по применению компонента;
- Поставка образцов и прототипов;
- Техническая поддержка проекта;
- Защита от снятия компонента с производства.



#### Как с нами связаться

**Телефон:** 8 (812) 309 58 32 (многоканальный)

**Факс:** 8 (812) 320-02-42

**Электронная почта:** [org@eplast1.ru](mailto:org@eplast1.ru)

**Адрес:** 198099, г. Санкт-Петербург, ул. Калинина, дом 2, корпус 4, литера А.