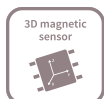


# 3D Magnetic Sensor 2 Go - TLE493D-A2B6

## Low Power 3D Hall Sensor with I<sup>2</sup>C Interface

TLE493D-A2B6 3D-MS2GO

### User Manual



### About this document

#### Scope and purpose

This document provides an introduction to the 3D Magnetic Sensor 2 Go kit and should enable the reader to efficiently carry out own evaluations with the 3D magnetic sensor TLE493D-A2B6.

#### Intended audience

This document is aimed at everyone who wants to work with the 3D Magnetic Sensor 2 Go evaluation kit.

## Table of contents

	<b>User Manual</b> .....	1
	<b>About this document</b> .....	1
	<b>Table of contents</b> .....	2
<b>1</b>	<b>Introduction</b> .....	3
1.1	Hardware overview .....	3
1.2	Software .....	3
1.3	Magnet heads .....	3
<b>2</b>	<b>EvalBoard description</b> .....	6
2.1	Optional external power supply .....	6
2.2	Pin header connector .....	7
2.3	EvalBoard schematics .....	8
<b>3</b>	<b>Software installation</b> .....	12
3.1	Driver installation .....	15
<b>4</b>	<b>3D magnetic sensor evaluation</b> .....	19
4.1	Getting started .....	19
4.2	Graph View .....	20
4.3	Joystick view .....	21
4.4	Polar coordinates .....	21
	<b>Revision history</b> .....	22
	<b>Disclaimer</b> .....	23

## Introduction

# 1 Introduction

Infineon's **3D Magnetic Sensor 2 Go** is a compact evaluation kit to familiarize the user with the 3D Hall sensor TLE493D-A2B6. In a short time the board is set up and own 3D magnetic measurements can be executed. All required hardware is included and the software can be downloaded for free from the Infineon web page.

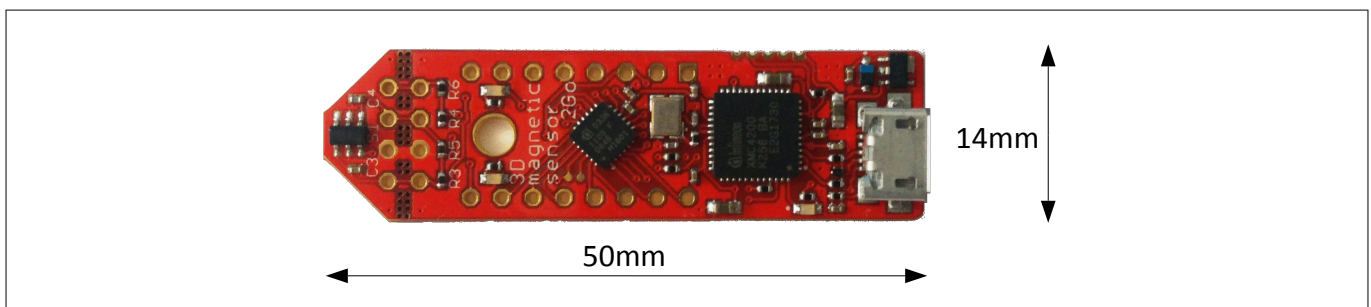
This user manual describes the different parts of the board, the software installation process and clarifies how the Graphical User Interface (GUI) can be used to do first evaluations.

## 1.1 Hardware overview

The 3D Magnetic Sensor 2 Go kit contains:

- The 3D evaluation board (EvalBoard) as shown in **Figure 1**, a ready-to-use printed circuit board (PCB) with the 3D Hall sensor. The EvalBoard is based on the XMC2Go-Kit. More technical documents and detailed description can be found at <http://www.infineon.com/xmc2go>.
- A standalone block magnet.

To use the 3D Magnetic Sensor 2 Go kit the user has to acquire a USB cable with a micro USB connection-end for the EvalBoard side and a conventional USB connection for the PC side.



**Figure 1** 3D Magnetic Sensor 2 Go EvalBoard

## 1.2 Software

The required software to run the kit can be found at the Infineon web site. For further information refer to the chapter **Software installation**.

The software package contains:

- A Graphical User Interface (GUI) for the user sensor evaluation.
- Firmware to be flashed into the XMC microcontroller for the low level communication with the sensor.
- USB driver J-Link from Segger which is necessary to establish the USB connection.

This software was designed to be used with Windows 7 and Windows 10. It is compatible with both 32-bit and 64-bit system types. Other versions may also work, but have not been tested.

The USB protocols capabilities are defined by the Segger driver. Versions USB 2.0 and USB 3.0 should be compatible.

The EvalBoard with the TLE493D-A2B6 3D Hall sensor can be used with the GUI version 3.0.0 and onwards.

The GUI is used to enable a communication between the sensor and the PC. The user can configure the sensor to operate in different modes. In those modes the update rate of the magnetic field measured (X, Y and Z components) and current consumption vary.

## 1.3 Magnet heads

As described in **Chapter 1.1**, a standalone magnet is provided with the 3D Magnetic Sensor 2 Go kit. This can be manually placed to a desired position and then the magnetic field can be measured in the three dimensions.

**Introduction**

In addition, Infineon offers magnet heads which can be mounted on the EvalBoard. Currently two magnetic heads are available, a joystick and a rotation knob.

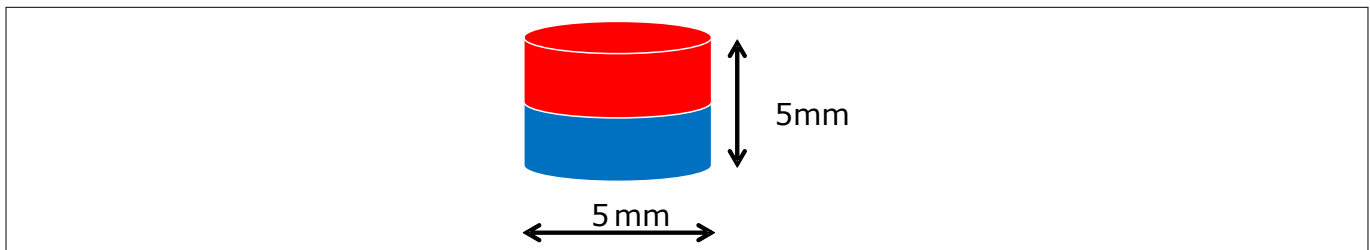
**Table 1 Magnet heads order codes**

Magnet head for the 3D Magnetic Sensor 2 Go kit	SP Number
Joystick	SP001491834
Rotation knob	SP001504602



**Figure 2 Magnet heads for the 3D Magnetic Sensor 2 Go kit**

The magnet used in the joystick magnet head is an axial magnetized magnet as shown in [Figure 3](#). The magnet material is ferrite, of class Y35, which is equivalent to a remanence of between 400 mT and 410 mT. The magnet disk has a size of 5 mm diameter and 5 mm thickness. For more information about the magnet, please follow this link: [https://www.supermagnete.de/eng/disc-magnets-neodymium/disc-magnet-diameter-5mm-height-5mm-neodymium-n45-nickel-plated\\_S-05-05-N](https://www.supermagnete.de/eng/disc-magnets-neodymium/disc-magnet-diameter-5mm-height-5mm-neodymium-n45-nickel-plated_S-05-05-N)

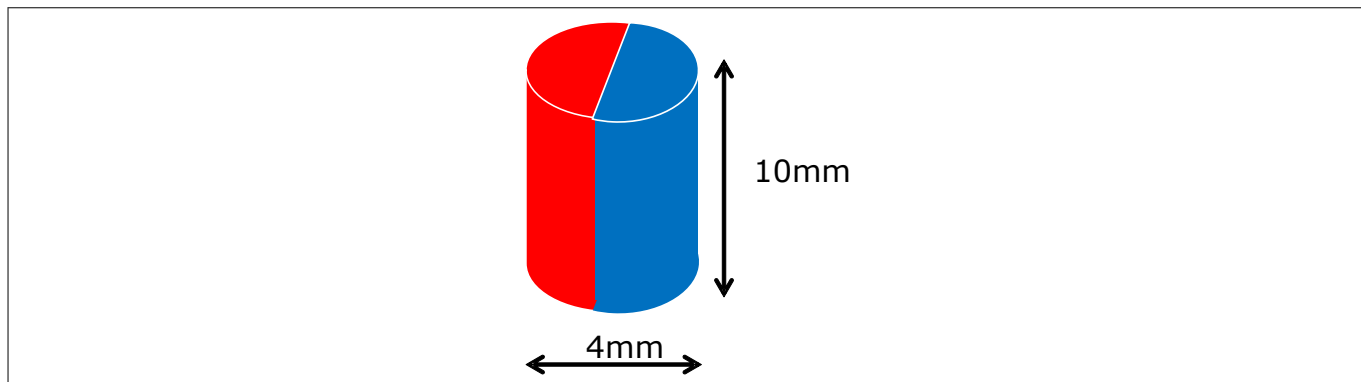


**Figure 3 Magnet used in the joystick magnet head**

The magnet used in the rotate knob magnet head is a diametrically magnetized magnet as shown in [Figure 4](#). The magnet material is Neodymium Iron Boron (NdFeB) of class N45. The magnet is protected against corrosion with Nickel coating (Ni-Cu-Ni). The magnet size is 4 mm diameter and 10 mm thickness. For more information about the magnet, please follow this link: [https://www.supermagnete.de/eng/rod-magnets-neodymium/rod-magnet-diameter-4mm-height-10mm-neodymium-n45-nickel-plated\\_S-04-10-AN](https://www.supermagnete.de/eng/rod-magnets-neodymium/rod-magnet-diameter-4mm-height-10mm-neodymium-n45-nickel-plated_S-04-10-AN)

**Introduction**

---



**Figure 4**      **Magnet used in the rotation knob magnet head**

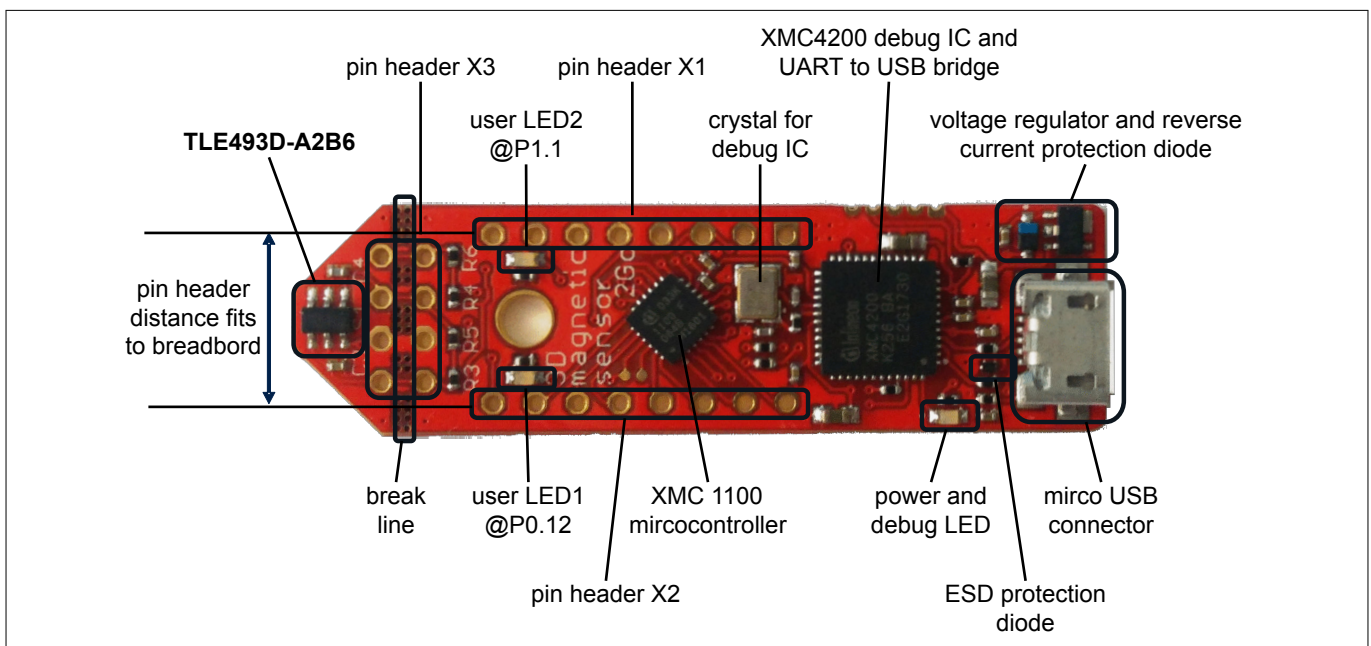
**EvalBoard description**

## 2 EvalBoard description

The evaluation board (EvalBoard) is a ready-to-use printed circuit board (PCB) which contains:

- The 3D magnetic sensor TLE493D-A2B6. For the availability of 3D Magnetic Sensor 2 Go kits with different sensor variants check the Infineon web page: <https://www.infineon.com/cms/en/product/sensor/magnetic-position-sensor/3d-magnetic-sensor/>
- XMC1100 microcontroller based on ARM Cortex™-M0 at 48 MHz frequency connected to the 3D sensor.
- XMC4200 microcontroller based on ARM Cortex™-M4 at 144 MHz frequency used for the debugging and the USB communication.
- Micro USB connector for power supply and communication with the Graphical User Interface (GUI).
- LED for indication of power supply and debugging.
- Two LEDs for user configuration.
- Voltage regulator, reverse current protection diode and ESD protection diode.
- Pin headers to access data lines (e.g. via oscilloscope, external microcontroller).

The different components and its location are shown in **Figure 5**. The 3D magnetic sensor can be separated from the rest of the EvalBoard by cutting the break line.



**Figure 5 Main components of the EvalBoard**

### 2.1 Optional external power supply

The 3D Magnetic Sensor 2 Go EvalBoard is supplied via the USB cable. It is also possible to provide an external power supply. If this is the case, a few considerations must be taken into account as described below.

The 3D Magnetic Sensor 2 Go EvalBoard must be supplied by external 5 Volt DC power supply connected to the micro USB plug. The voltage regulator shifts the voltage level to 3.3 V for the microcontrollers and the 3D magnetic sensor. The Power & Debug LED indicates that the presence of the generated 3.3 V supply voltage.

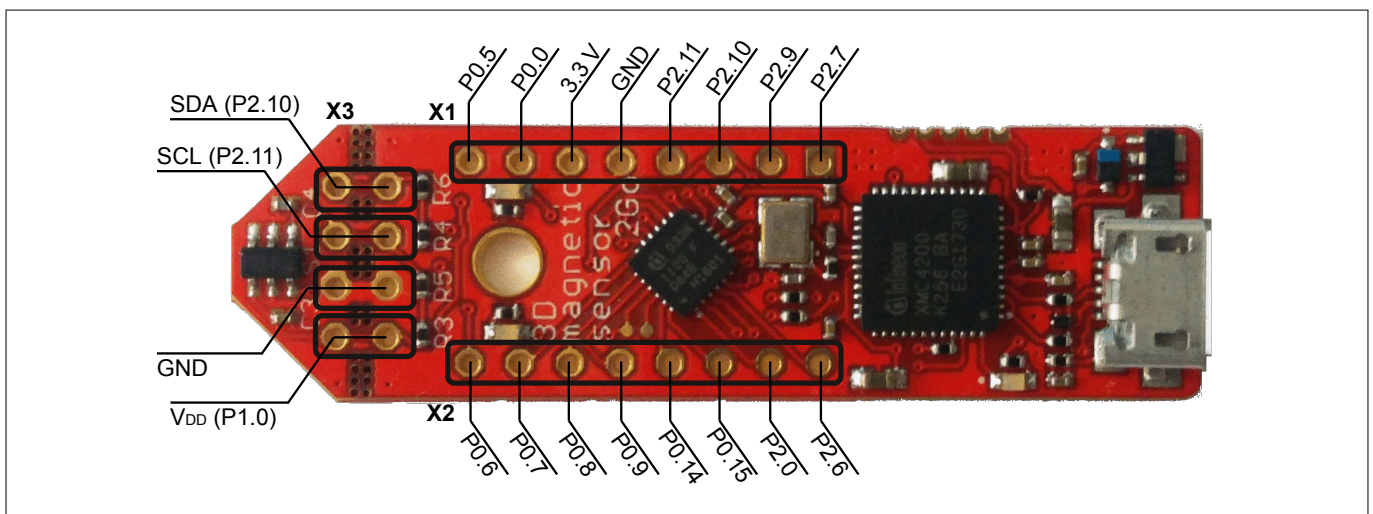
Out of the box with the pre-programmed application and the on-board debugger in operation the EvalBoard typically draws about 75 mA. This current can be delivered via the USB plug of a PC, which is specified to deliver up to 500 mA. An on-board reverse current protection diode will ensure safe operation and protects the USB port of the Laptop/PC in case power is provided through the pin header X1.

**EvalBoard description**

It is not recommended to apply an additional power supply to the V<sub>DD</sub> pin of X1 (3.3 V) when the board is powered via USB, because the 3.3 V supply could drive against the on-board power supply. The V<sub>DD</sub> pin can be used to power an external circuit. But care must be taken not to draw more current than 150 mA, which is the maximum current the on-board voltage regulator can deliver. After power-up the Debug LED starts blinking. In case there is connection to a PC with correctly installed drivers, the Debug LED will turn from blinking to constant illumination.

**2.2 Pin header connector**

The pin headers X1 and X2 can be used to extend the evaluation board or to perform measurements on the XMC1100. The order of pins available at X1 and X2 corresponds to the pinning schema of the XMC1100 microcontroller in the TSSOP-16 pin package. The pinning table is also printed onto the bottom side of the PCB (depending on the version). The pin header X3 can be used to access directly the 3D magnetic sensor pins.



**Figure 6 EvalBoard pin header connectors**

The 3D Hall sensor pins can be accessed via the pin headers as shown in [Table 2](#).

**Table 2 Pin header description for the 3D magnetic sensor (X3)**

TLE493D-A2B6 pin number	Pin name on board	XMC1100 port pin	Sensor pin description
1	SCL	P2.11	Interface clock and \INT pin, open drain
3	GND	GND	Ground pin
4	+3V3	P1.0	Supply pin
6	SDA	P2.10	Interface data pin, open drain

The XMC1100 port pins P0.12 and P1.1 are connected the two user LEDs and are not available on the pin headers.

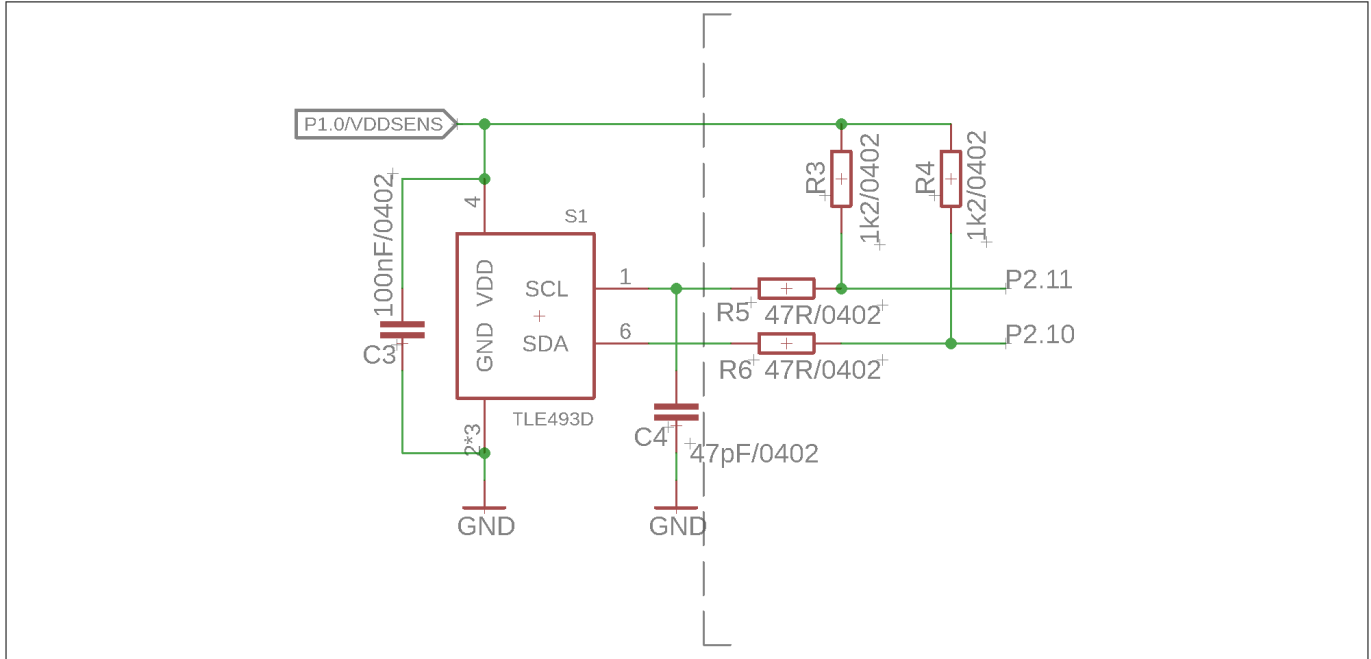
**Table 3 Pins used for the user LEDs**

LED	XMC1100 port pin
LED1	P0.12
LED2	P1.1

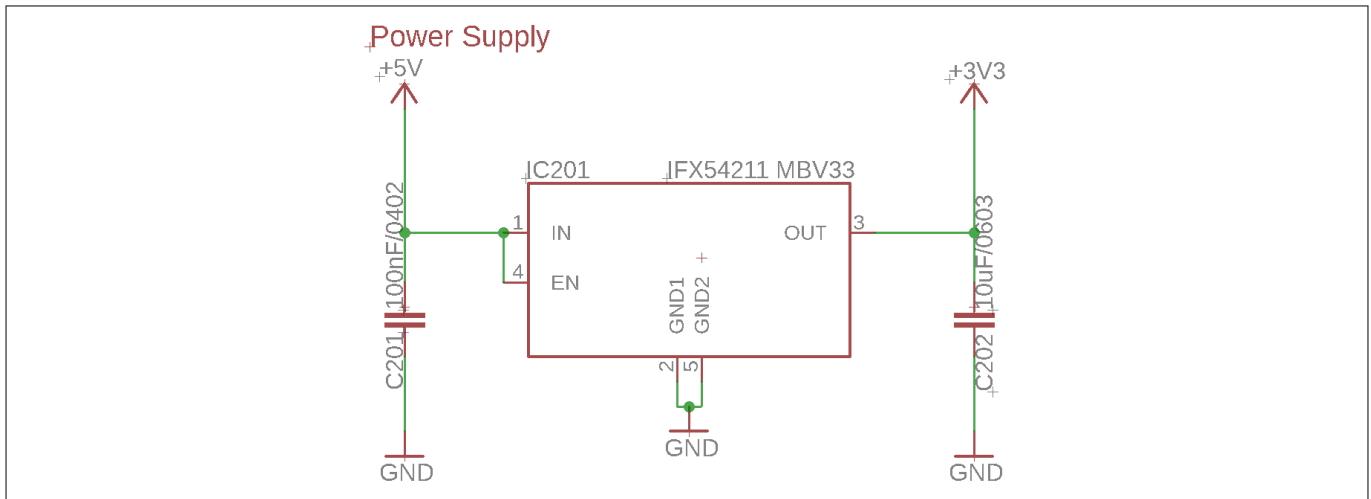
**EvalBoard description**

**2.3 EvalBoard schematics**

The schematics of the different blocks from the EvalBoard of the 3D Magnetic Sensor 2 Go kit are provided in this chapter. They can be used to design customized PCBs. The user (integrator) is responsible for the correct functioning on system level as well as for the validation and testing.



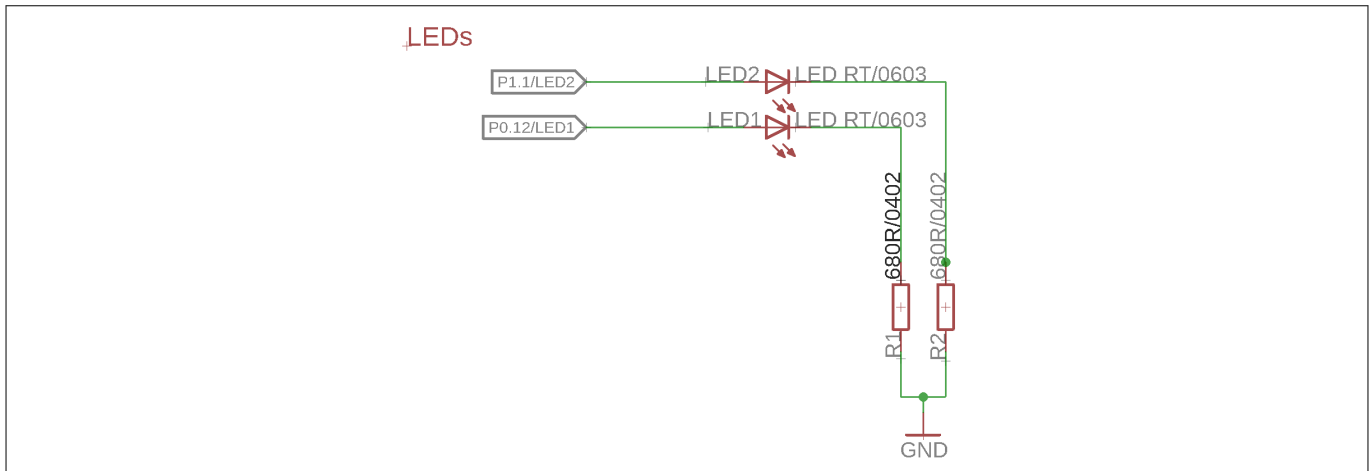
**Figure 7 EvalBoard schematic: 3D magnetic sensor**



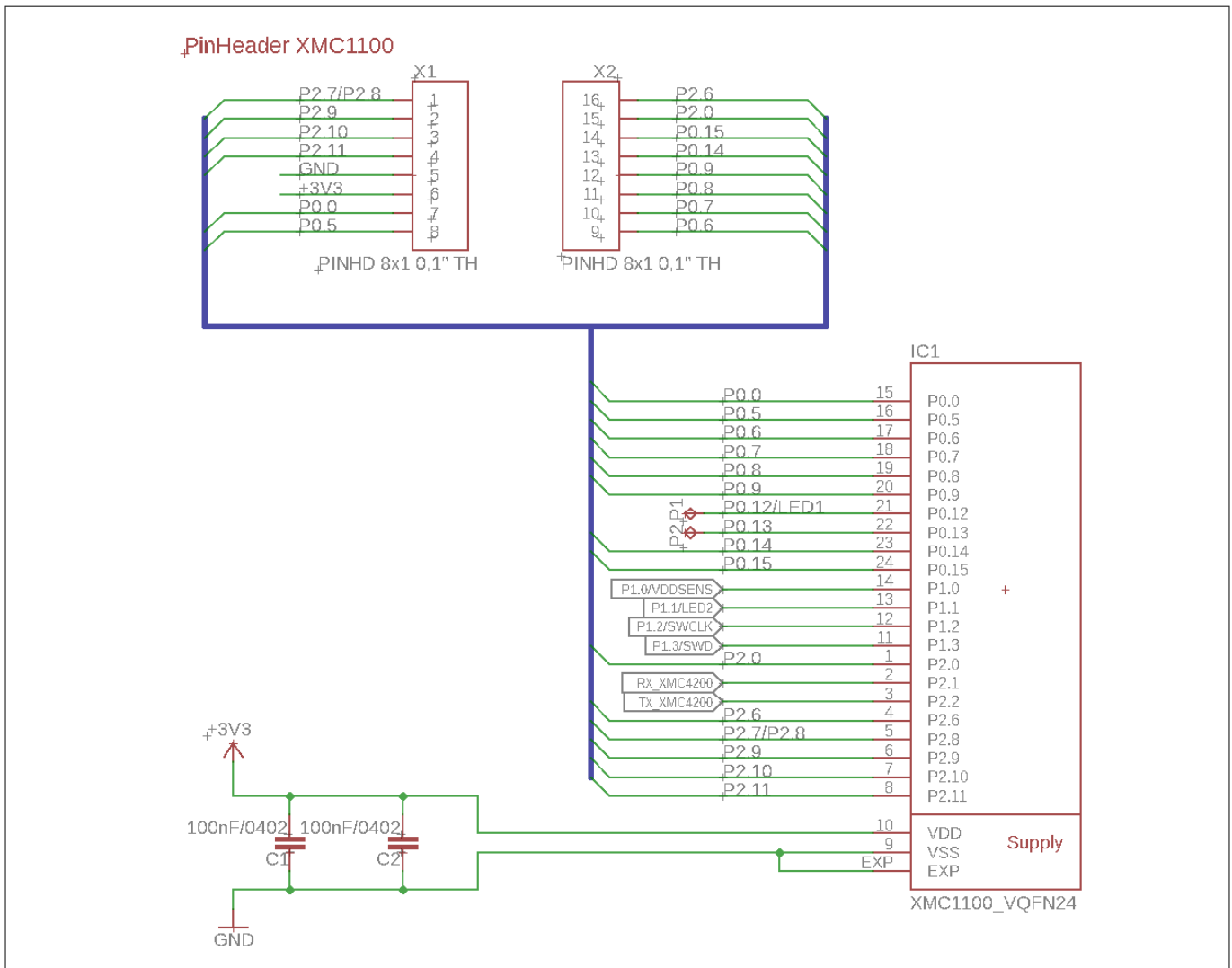
**Figure 8 EvalBoard schematic: the voltage regulator (for the power supply)**



**EvalBoard description**

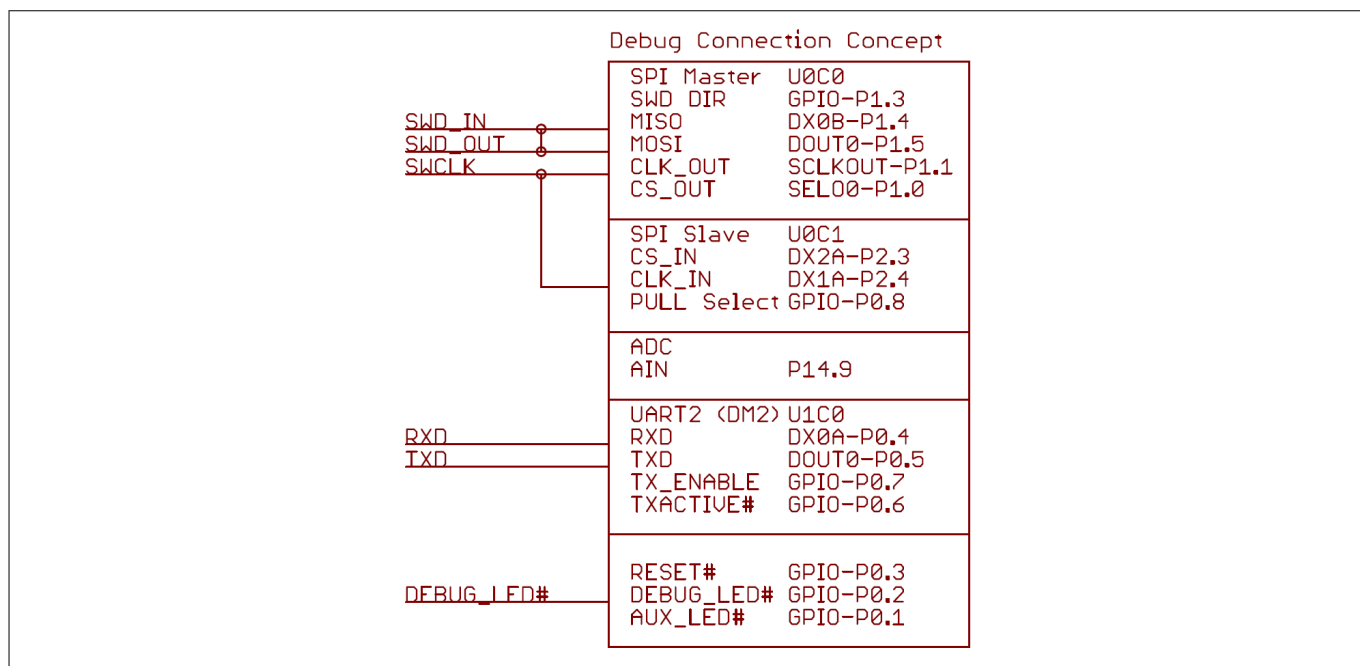


**Figure 9 EvalBoard schematic: the LEDs for user configuration (connected to XMC1100 pins)**



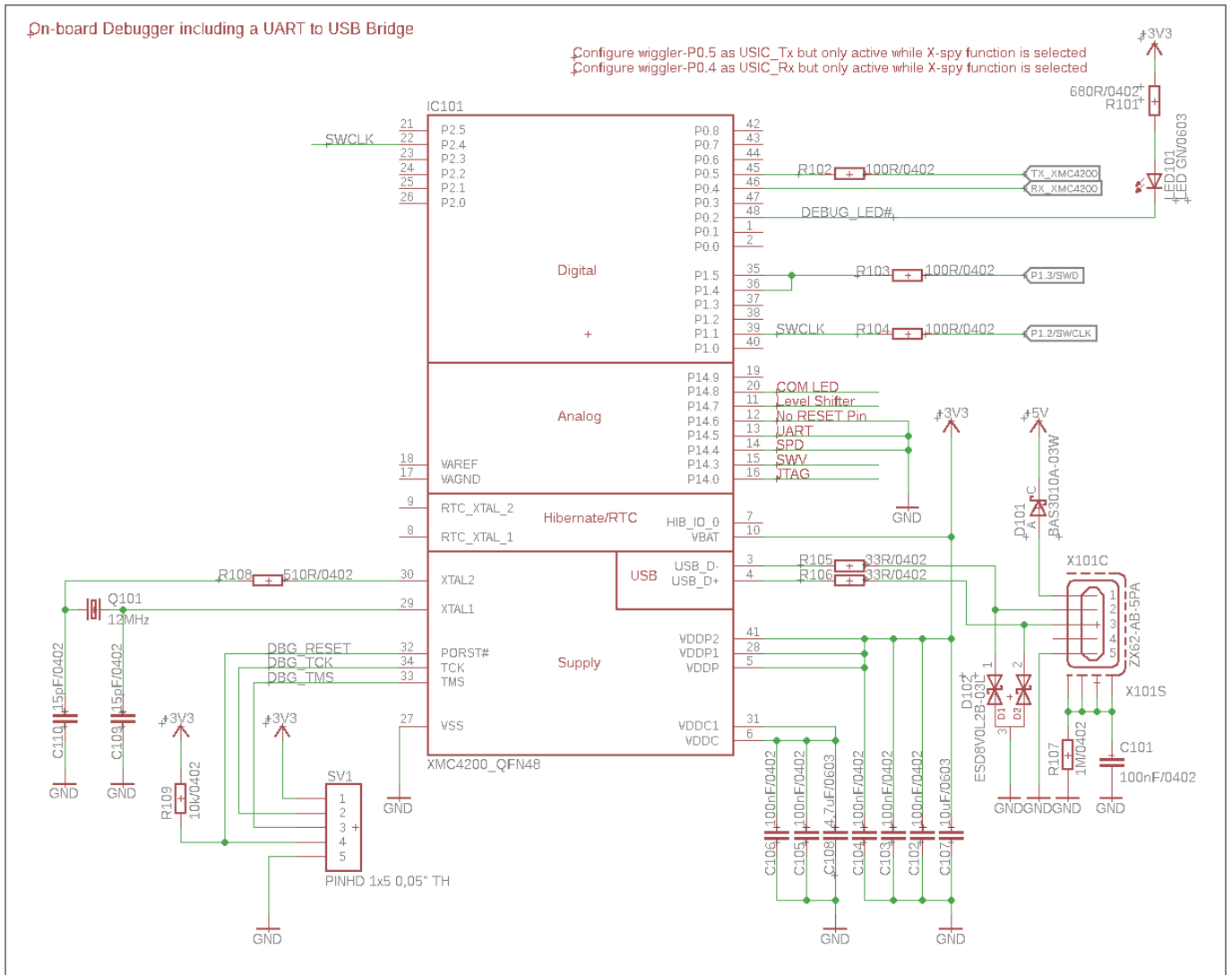
**Figure 10 EvalBoard schematic: the XMC1100 microcontroller and pin headers**

**EvalBoard description**



**Figure 11** EvalBoard schematic: the Debug connection

**EvalBoard description**



**Figure 12 EvalBoard schematic: the XMC4200 microcontroller and micro USB connector**

Software installation

### 3 Software installation

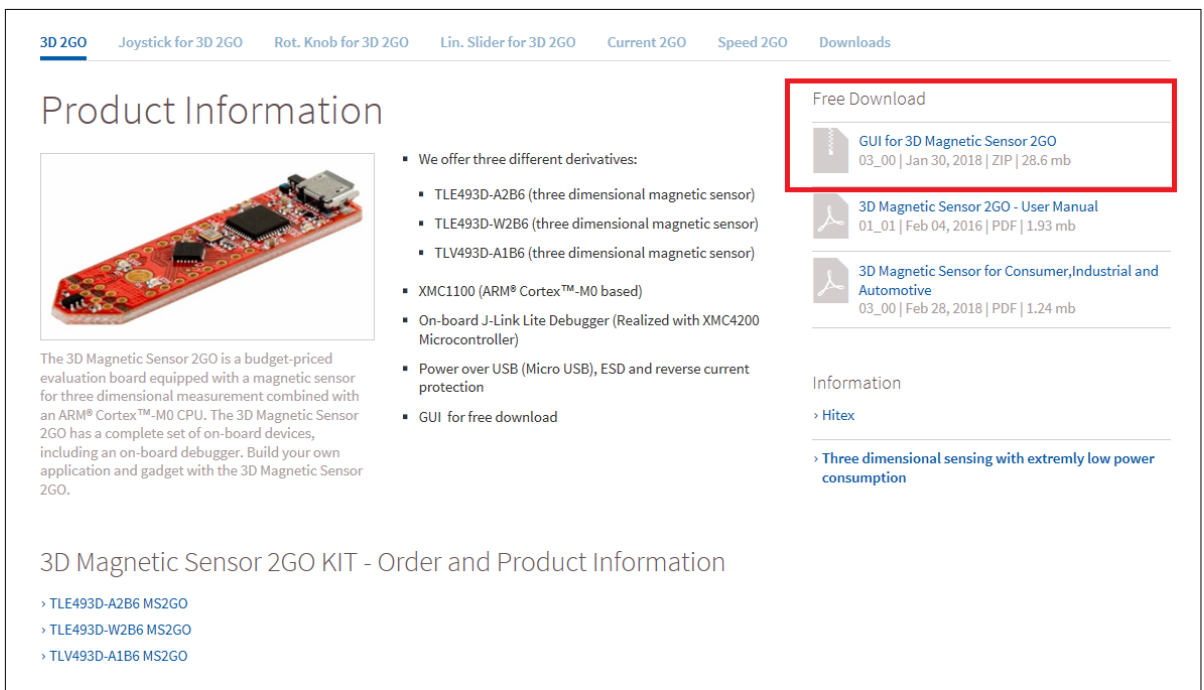
The following description guides through the installation procedure of the free evaluation software for the 3D Magnetic Sensor 2 Go kit.

Steps

1. Download the software.

Follow the link below to reach the **Sensor 2 Go** information page on the Infineon website. As shown in **Figure 13**, you can find the download link for the latest version of the 3D Magnetic Sensor 2 Go GUI on the right hand side.

<https://www.infineon.com/cms/en/product/promopages/sensors-2go/>



**Figure 13** Download the "3D Magnetic Sensor 2 Go" software from the Infineon web page

2. Start the installation process.

Browse to your download folder and extract the downloaded .zip file. Afterwards, double click on the .msi file to start the installer. The window in **Figure 14** pops up. Click "Next".

Software installation

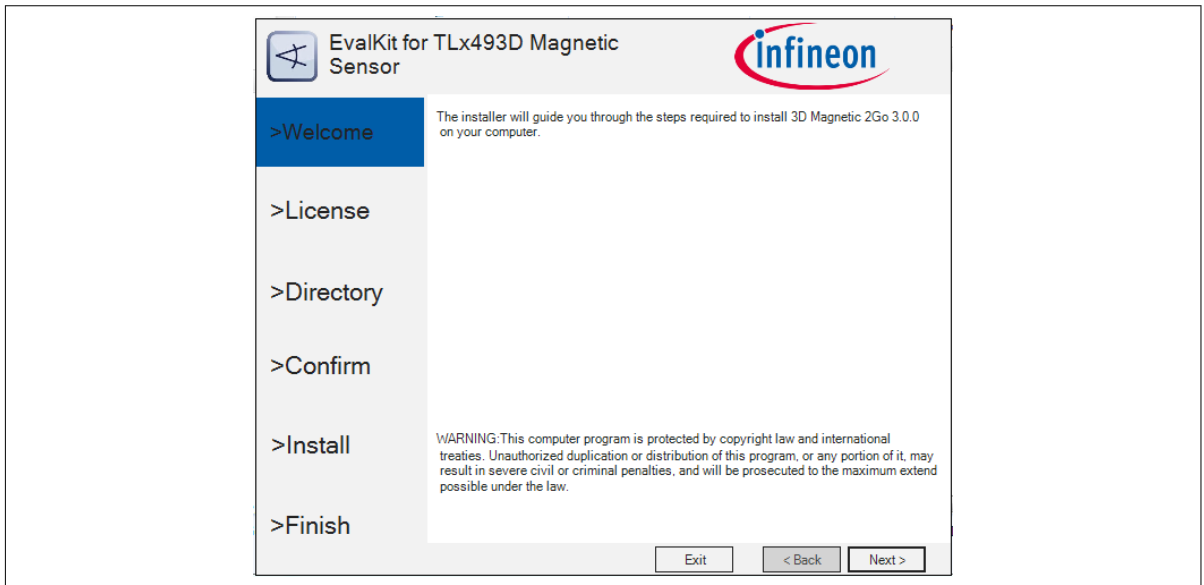


Figure 14 Start the software installation

- 3. Read the license agreement carefully and tick the box to accept the terms. Click **Next**.

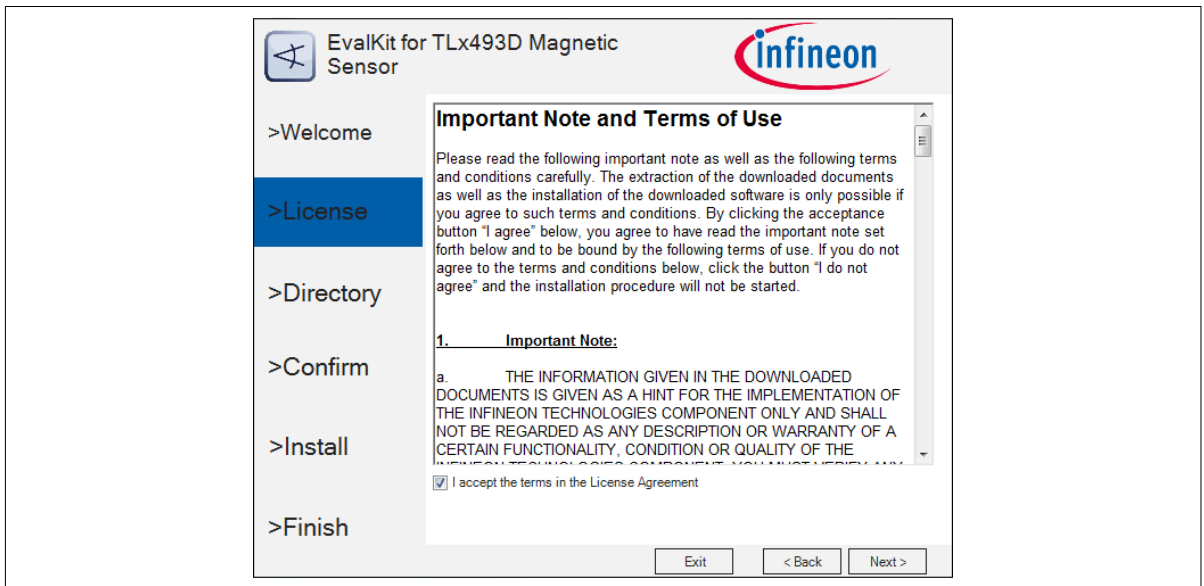
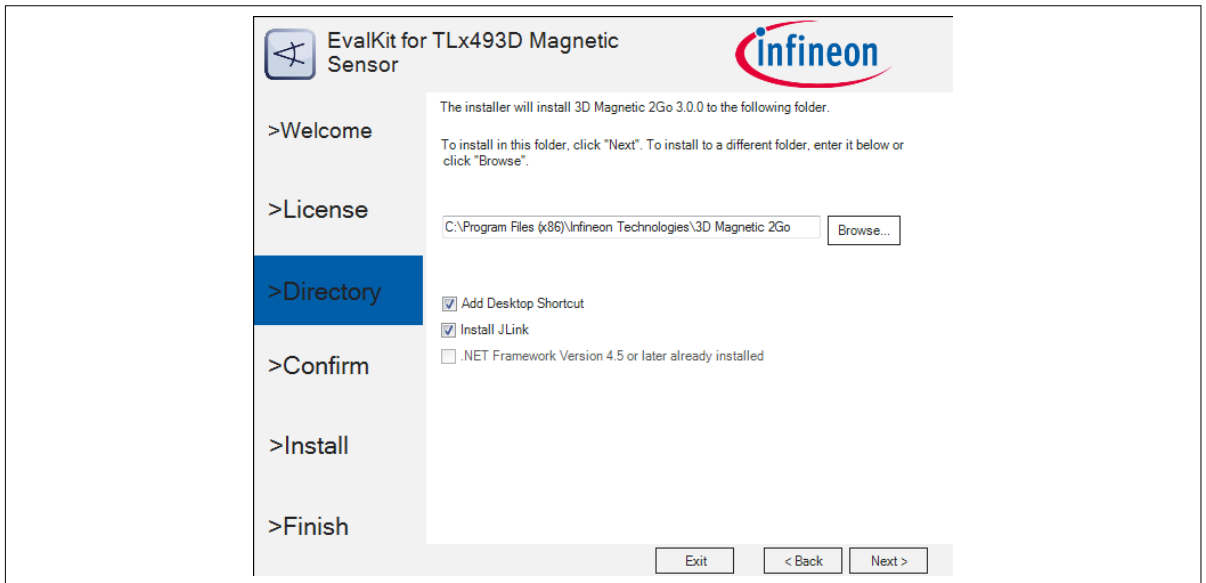


Figure 15 Accept the license agreement

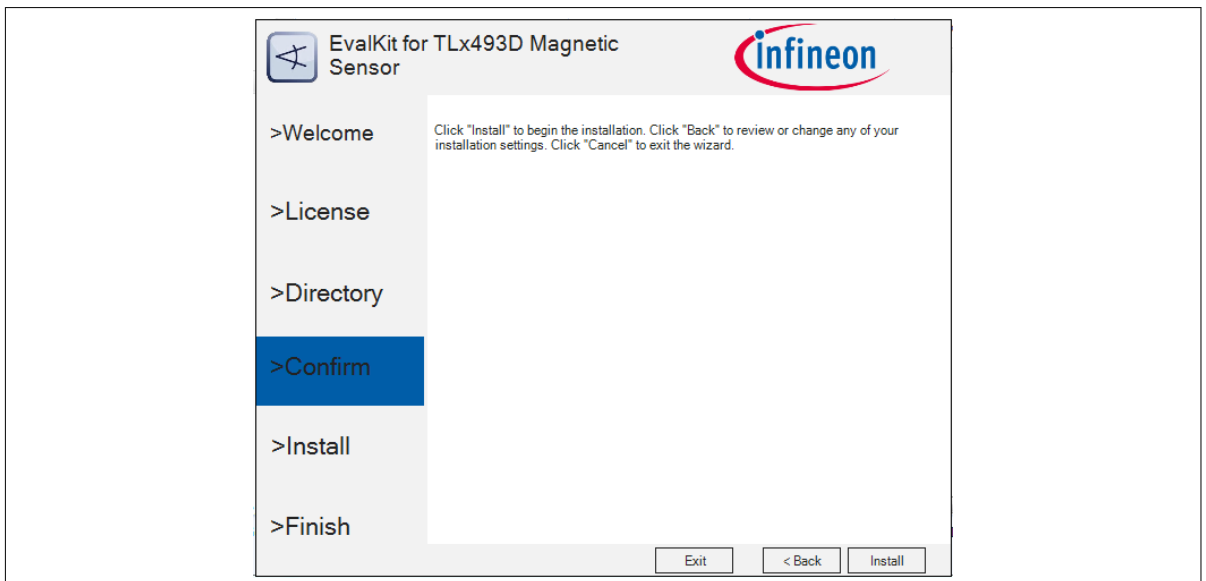
- 4. Choose your installation path and check that the SEGGER J-Link driver will be installed. Click **Next**

### Software installation



**Figure 16** Select you installation folder

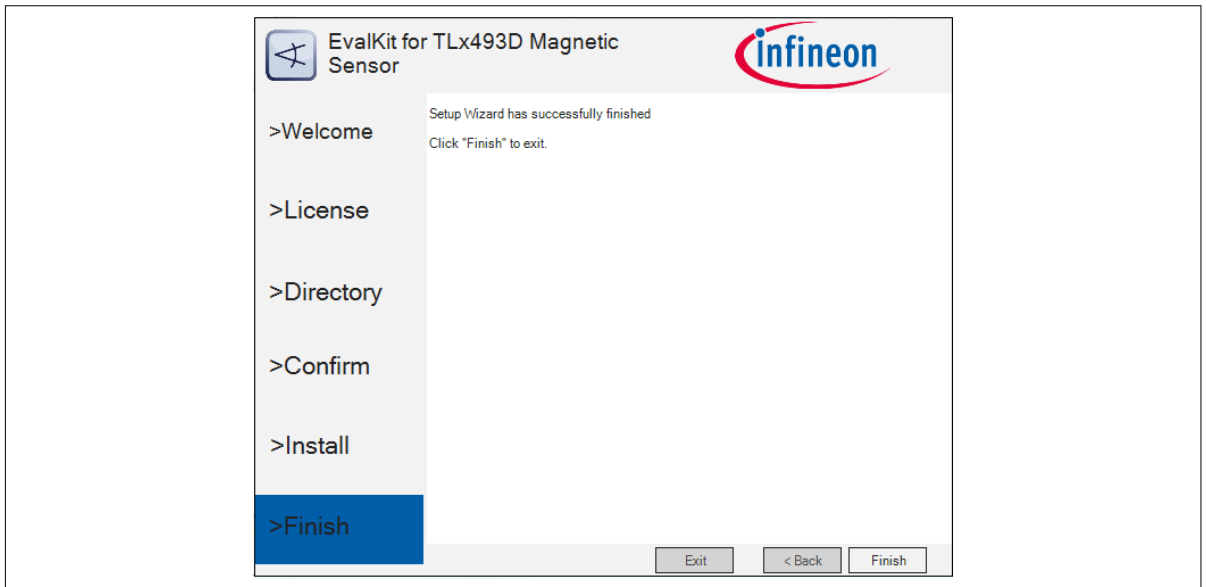
5. Confirm the installation settings by clicking on **Install**.



**Figure 17** Confirm the installation

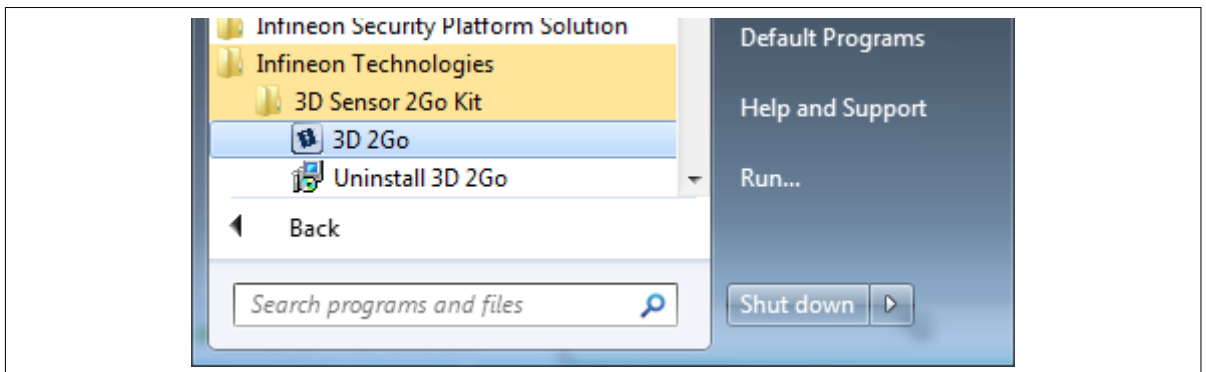
6. Once the installation is complete, click on **Finish** to close the installer.

**Software installation**



**Figure 18** Installation finished

7. You can now start the evaluation software. Open the start menu, browse to **Infineon Technologies > 3D Sensor 2go Kit** and open the application by clicking on **3D 2Go**.



**Figure 19** Shortcut to the 3D Magnetic 2Go evaluation software (GUI)

### 3.1 Driver installation

To enable the communication between the 3D Magnetic Sensor 2 Go kit it is necessary to install the J-Link driver on your PC.

The driver is included in the GUI installer and will start automatically within the installation progress. In case of issues, you can directly download the latest version from the SEGGER homepage:

<https://www.segger.com/downloads/jlink>

#### Steps

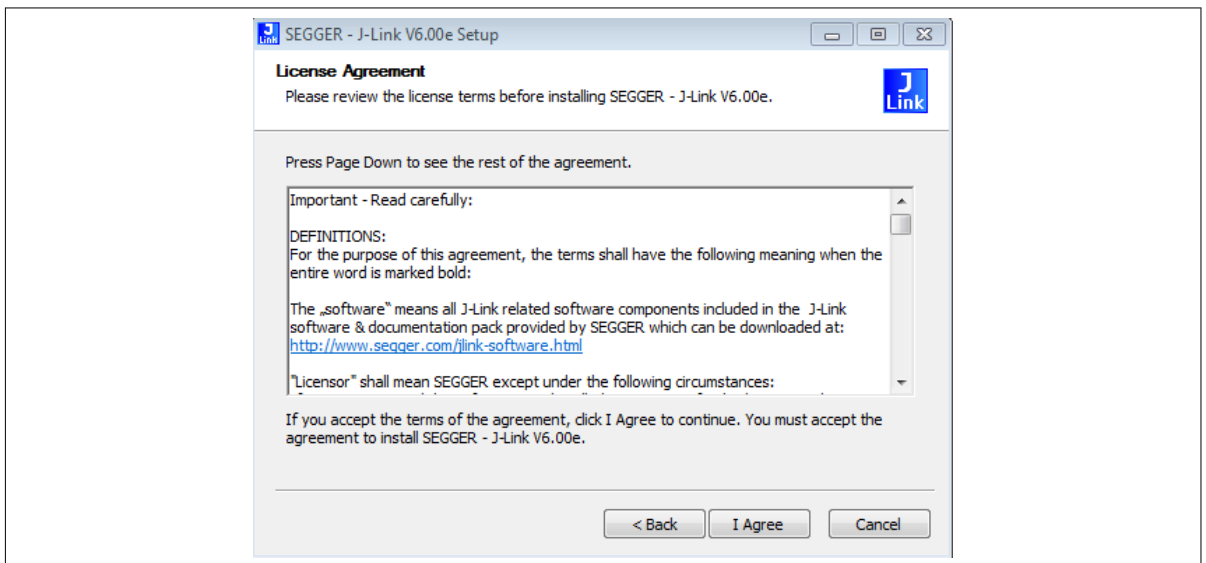
1. Start the installation. Invoke your downloaded driver executable or wait for the 3D Magnetic Sensor 2 Go installer to open the window shown in **Figure 20**. Click on **Next**.

Software installation



**Figure 20** J-Link driver setup

2. Read and accept the license agreement. Click on **I Agree**.



**Figure 21** J-Link license agreement

3. Check that the "Install USB Driver for J-Link" option is active. Click on **Next**.



Software installation

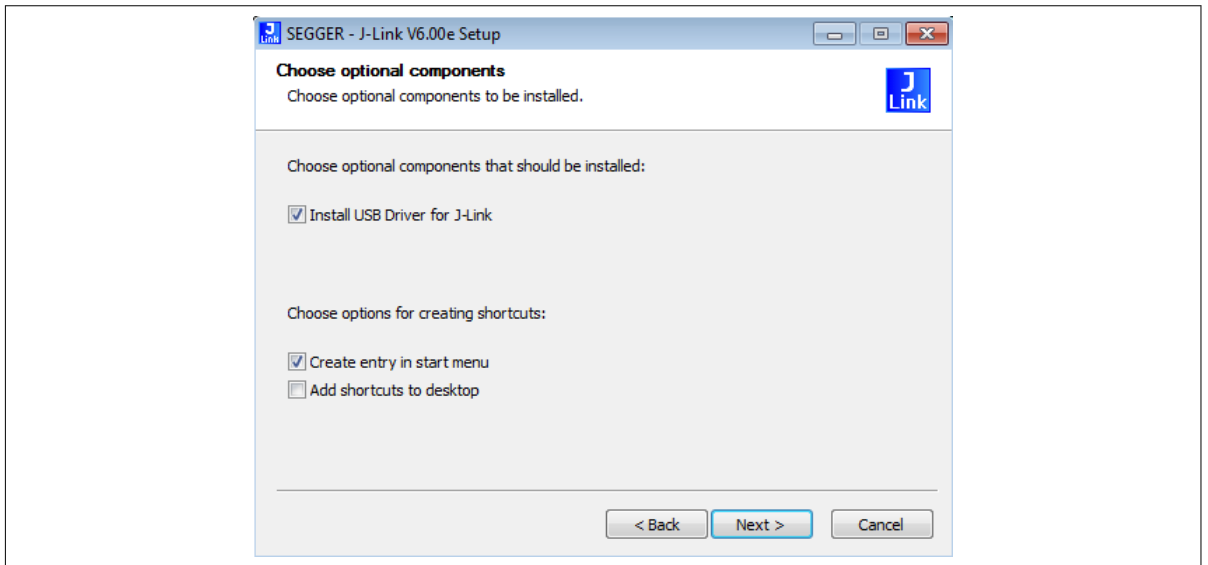


Figure 22 J-Link installation options

4. Choose the installation folder. It is recommend to keep the default settings. Click on **Install**. Now the installation should be executed.

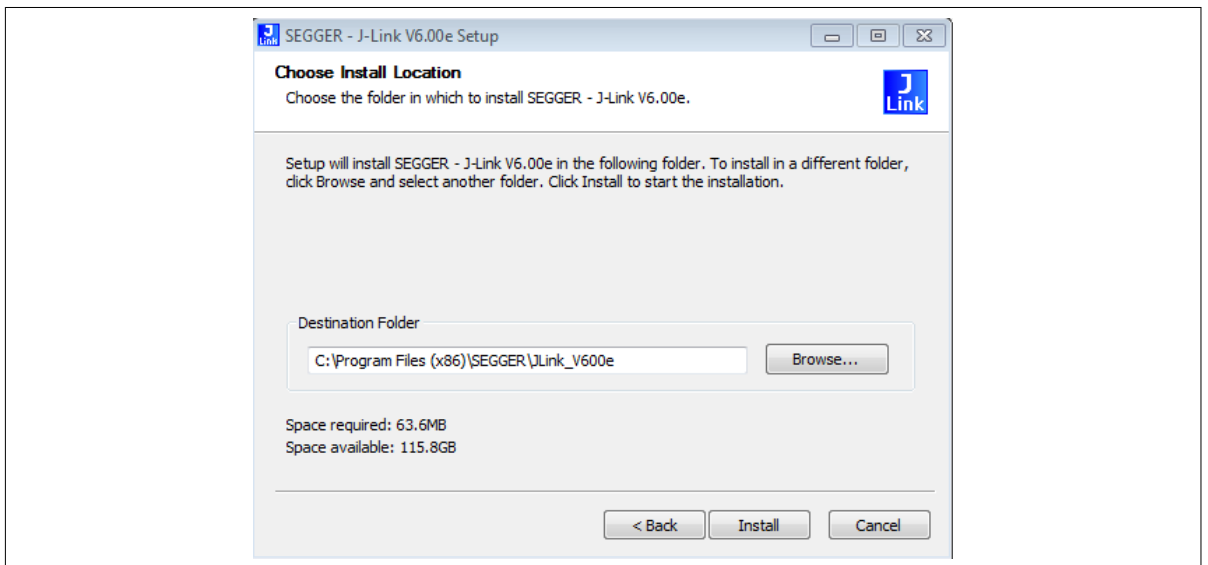


Figure 23 J-Link choose install location

5. Once the installation is completed, close the installer by clicking on **Finish**.

**Software installation**



**Figure 24**      **J-Link installation complete**

**3D magnetic sensor evaluation**

## 4 3D magnetic sensor evaluation

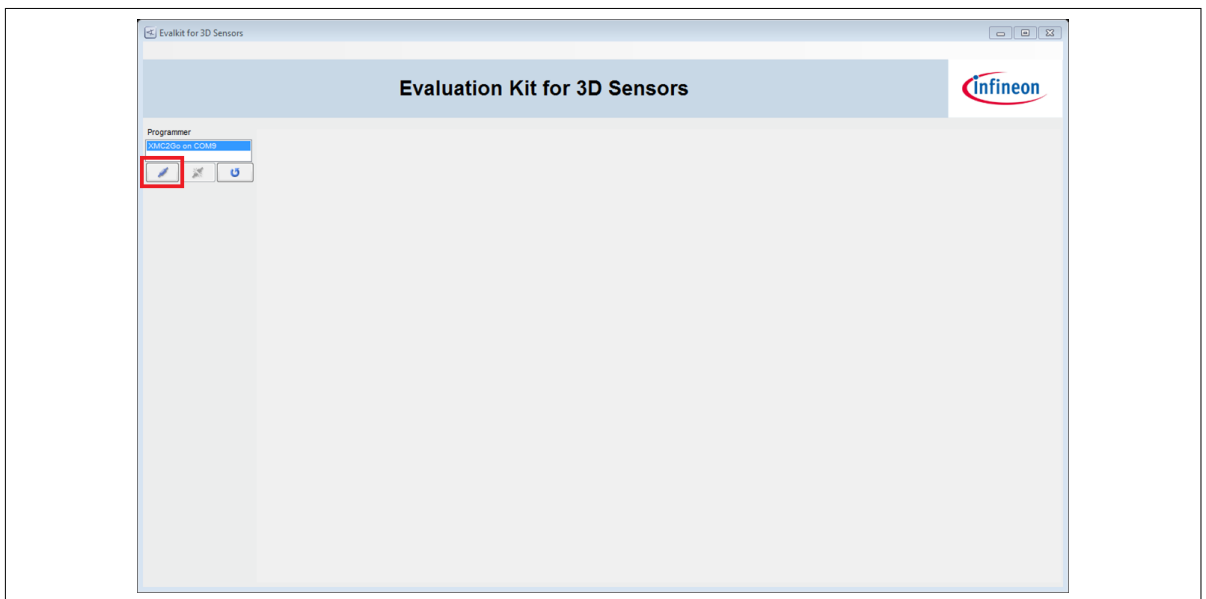
This chapter describes how the GUI can be used to make first evaluations with Infineon's 3D magnetic sensor.

### 4.1 Getting started

Once the software is installed, the following steps are necessary to do the first magnetic measurements.

**Steps**

1. Connect the EvalBoard to the PC via the USB cable. Use the micro USB port for the EvalBoard and USB port for the PC. The power LED on the EvalBoard will switch on, indicating the EvalBoard is supplied with enough power.
2. Open the 3D 2Go GUI by clicking the shortcut in the start menu. On the top left side you should find the XMC2Go board in the list. If not, check that the EvalBoard is correctly connected to the PC and the J-Link driver is installed. Click on the **Connect to selected programmer button** which is marked in [Figure 25](#) to establish the connection with the 3D Magnetic Sensor 2 Go kit. The first time you connect the board, a firmware will be downloaded to the XMC1100 which takes short time. This is indicated by the blinking power LED on the EvalBoard.



**Figure 25 Establish the connection to the EvalBoard**

3. The GUI automatically detects the sensor type on the 3D Magnetic Sensor 2 Go kit. Now you can select the mode configuration. The GUI supports three sensor modes for the TLE493D-A2B6. They are briefly described in [Table 4](#). For details refer to the TLE493D-A2B6 data sheet and user manual. After you have selected the mode, click on **Start** to begin with the measurements.

**Table 4 Sensor modes**

Sensor mode	Description
Low power mode	Cyclic sensor measurements with a configurable update rate. The GUI sets the sensor to the default update rate of 770 Hz (typ.). Between the measurements, the sensor stays in power down mode, which reduces the power consumption.
Fast mode	Sensor measurements are running continuously. Fastest update rate.

3D magnetic sensor evaluation

**Table 4** Sensor modes (continued)

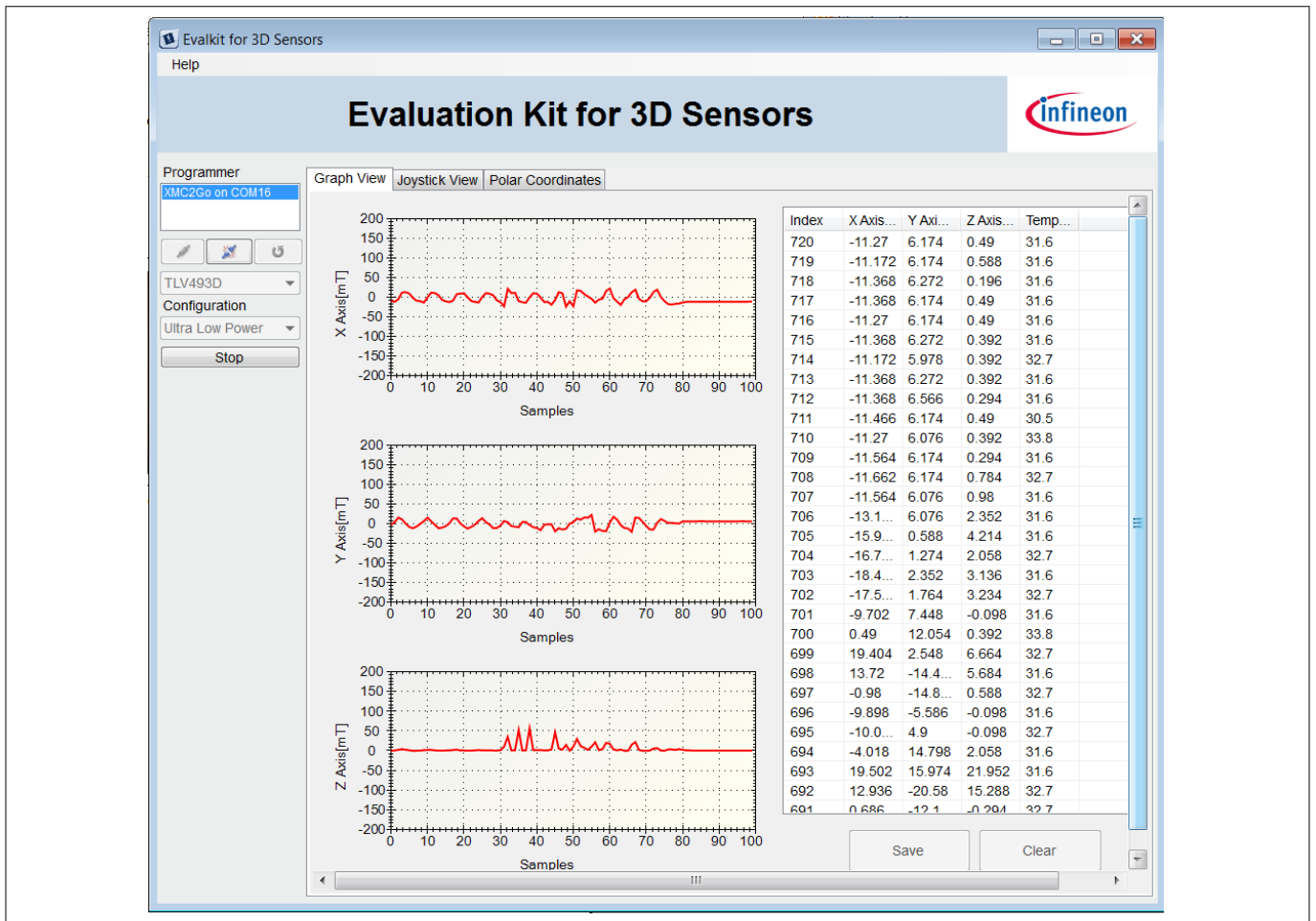
Sensor mode	Description
Master controlled mode	Sensor measurements are triggered by the microcontroller, which enables high flexibility.

**4.2 Graph View**

The graph view displays the magnetic field measurements in X, Y and Z direction.

**Figure 26** shows the graph view window. On the left hand side there are three histograms which plot the magnetic field for each measured sample. On the right a table displays all measured data, including the temperature. With the **save** button it is possible to export the measurement data into a .csv file. This is especially helpful for processing the data afterwards. .

If a new mode should to be evaluated click the **Stop** button on the left control panel. **Save** the data and **Clear** it. Select a new configuration and click again on **Start** to begin the new evaluation.



**Figure 26** Graph view

3D magnetic sensor evaluation

### 4.3 Joystick view

The joystick view is a virtual representation of a real joystick with an attached magnet, mounted above the 3D magnetic sensor.

It is intended to be used with the Joystick adapter available for the 3D Magnetic Sensor 2 Go kit. For order details and information about the used magnet refer to section [Magnet heads](#).

The software measures the magnetic field in all three dimensions and calculates the angles necessary to determine the joystick position. Further information is given in the application note "Infineon 3D Magnetic Sensor - How to Make a Magnetic Design for Joystick" which can be found on the Infineon home page.

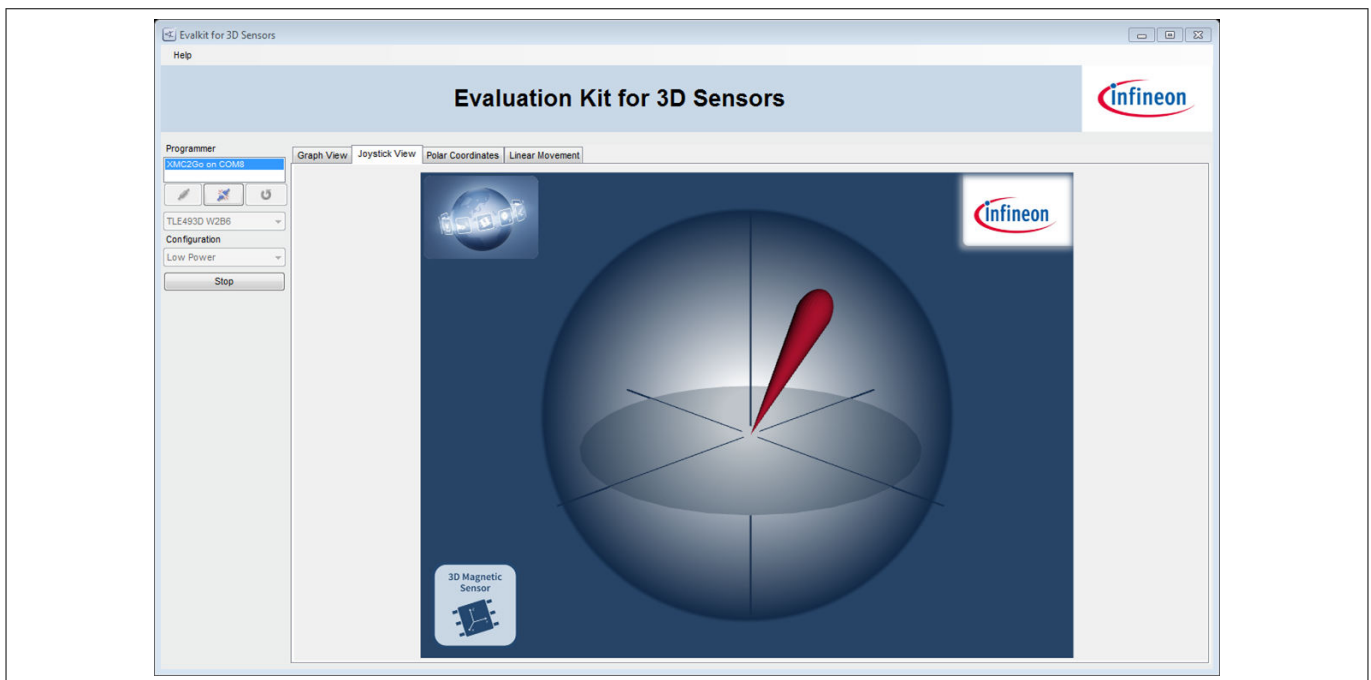


Figure 27 Joystick view

### 4.4 Polar coordinates

In this view the calculated spherical coordinates of the magnetic field are displayed. Additionally it includes a graphical presentation of the 3D Magnetic Sensor 2 Go rotary knob attachment .

The polar coordinates consist of the radius  $r$  as well as the angles Phi and Theta. They are calculated out of the measured three dimensional magnetic field with following equations:

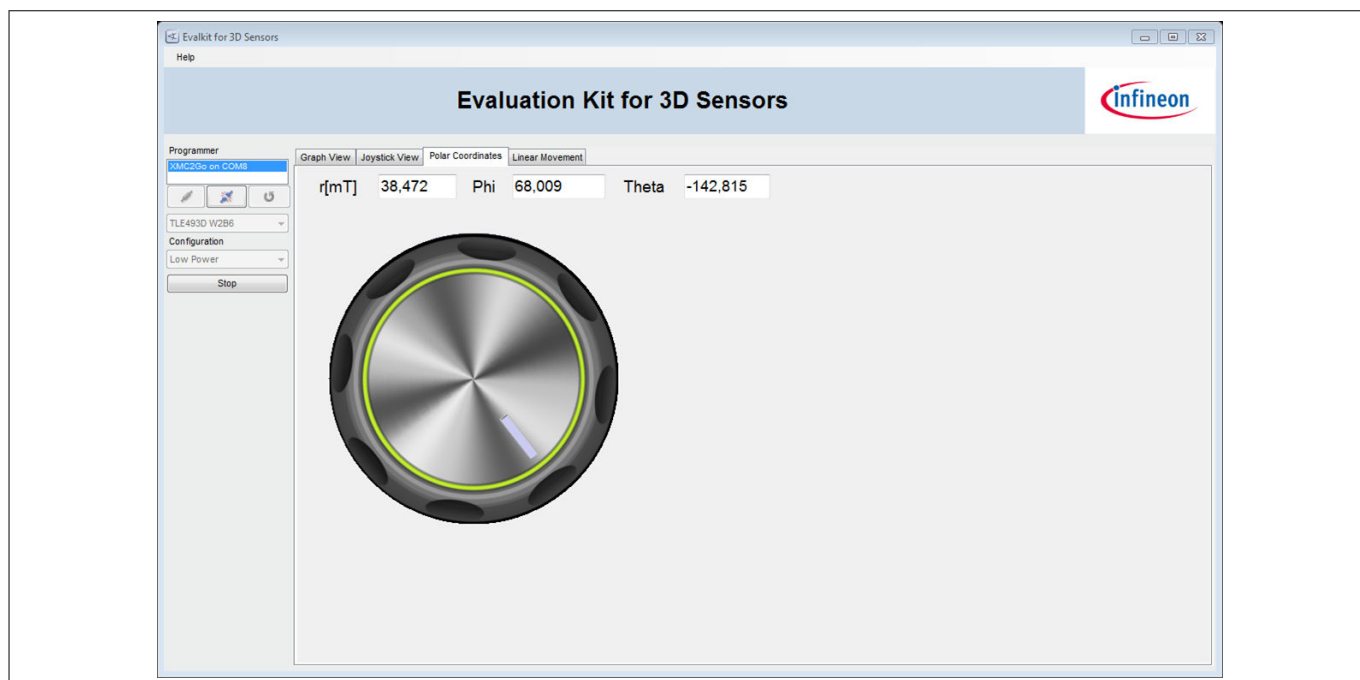
$$r = \sqrt{B_x^2 + B_y^2 + B_z^2}$$

$$\text{Phi} = \arccos \frac{B_z}{r}$$

$$\text{Theta} = \arctan \frac{B_y}{B_x}$$

Below the polar coordinates a virtual rotation knob can be found. It can be used with the rotary knob attachment described in [Magnet heads](#). When the user turns the hardware knob, also the knob in the GUI turns. This is achieved by measuring the magnetic field and calculating the angle between  $B_x$  and  $B_y$  as described above. Also a push functionality is implemented. When the user pushes the knob, the color of the direction stripe turns from white to green. This is based on the magnitude of the magnetic field.

**Revision history**



**Figure 28**      **Polar coordinates**

**Revision history**

<b>Document version</b>	<b>Date of release</b>	<b>Description of changes</b>
1.0	2018-05-16	Initial version.
1.1	2018-10-12	Title page updated.

## Trademarks

All referenced product or service names and trademarks are the property of their respective owners.

**Edition 2018-05-16**

**Published by**  
**Infineon Technologies AG**  
**81726 Munich, Germany**

**© 2018 Infineon Technologies AG**  
**All Rights Reserved.**

**Do you have a question about any**  
**aspect of this document?**  
**Email: [erratum@infineon.com](mailto:erratum@infineon.com)**

**Document reference**  
**IFX-hda1518789688364**

## IMPORTANT NOTICE

The information given in this document shall in no event be regarded as a guarantee of conditions or characteristics ("Beschaffheitsgarantie").

With respect to any examples, hints or any typical values stated herein and/or any information regarding the application of the product, Infineon Technologies hereby disclaims any and all warranties and liabilities of any kind, including without limitation warranties of non-infringement of intellectual property rights of any third party.

In addition, any information given in this document is subject to customer's compliance with its obligations stated in this document and any applicable legal requirements, norms and standards concerning customer's products and any use of the product of Infineon Technologies in customer's applications.

The data contained in this document is exclusively intended for technically trained staff. It is the responsibility of customer's technical departments to evaluate the suitability of the product for the intended application and the completeness of the product information given in this document with respect to such application.

## WARNINGS

Due to technical requirements products may contain dangerous substances. For information on the types in question please contact your nearest Infineon Technologies office.

Except as otherwise explicitly approved by Infineon Technologies in a written document signed by authorized representatives of Infineon Technologies, Infineon Technologies' products may not be used in any applications where a failure of the product or any consequences of the use thereof can reasonably be expected to result in personal injury



Компания «ЭлектроПласт» предлагает заключение долгосрочных отношений при поставках импортных электронных компонентов на взаимовыгодных условиях!

Наши преимущества:

- Оперативные поставки широкого спектра электронных компонентов отечественного и импортного производства напрямую от производителей и с крупнейших мировых складов;
- Поставка более 17-ти миллионов наименований электронных компонентов;
- Поставка сложных, дефицитных, либо снятых с производства позиций;
- Оперативные сроки поставки под заказ (от 5 рабочих дней);
- Экспресс доставка в любую точку России;
- Техническая поддержка проекта, помощь в подборе аналогов, поставка прототипов;
- Система менеджмента качества сертифицирована по Международному стандарту ISO 9001;
- Лицензия ФСБ на осуществление работ с использованием сведений, составляющих государственную тайну;
- Поставка специализированных компонентов (Xilinx, Altera, Analog Devices, Intersil, Interpoint, Microsemi, Aeroflex, Peregrine, Syfer, Eurofarad, Texas Instrument, Miteq, Cobham, E2V, MA-COM, Hittite, Mini-Circuits, General Dynamics и др.);

Помимо этого, одним из направлений компании «ЭлектроПласт» является направление «Источники питания». Мы предлагаем Вам помощь Конструкторского отдела:

- Подбор оптимального решения, техническое обоснование при выборе компонента;
- Подбор аналогов;
- Консультации по применению компонента;
- Поставка образцов и прототипов;
- Техническая поддержка проекта;
- Защита от снятия компонента с производства.



#### Как с нами связаться

**Телефон:** 8 (812) 309 58 32 (многоканальный)

**Факс:** 8 (812) 320-02-42

**Электронная почта:** [org@eplast1.ru](mailto:org@eplast1.ru)

**Адрес:** 198099, г. Санкт-Петербург, ул. Калинина, дом 2, корпус 4, литера А.