

Quad SPST CMOS Analog Switches

APPLICATIONS

- Audio switching
- Battery powered systems
- Data acquisition
- Sample-and-hold circuits
- Telecommunication systems
- Automatic test equipment
- Single supply circuits
- Hard disk drives

DESCRIPTION

The DG444, DG445 monolithic quad analog switches are designed to provide high speed, low error switching of analog signals. The DG444 has a normally closed function. The DG445 has a normally open function. Combining low power (22 nW, typ) with high speed (t_{ON} : 120 ns, typ.), the DG444, DG445 are ideally suited for upgrading DG211, DG212 sockets. Charge injection has been minimized on the drain for use in sample-and-hold circuits.

To achieve high-voltage ratings and superior switching performance, the DG444, DG445 are built on Vishay Siliconix's high-voltage silicon-gate process. An epitaxial layer prevents latchup.

Each switch conducts equally well in both directions when on, and blocks input voltages to the supply levels when off.

FEATURES

- Low on-resistance: 50 Ω
- Low leakage: 80 pA
- Low power consumption: 22 nW
- Fast switching action - t_{ON} : 120 ns
- Low charge injection
- DG211, DG212 upgrades
- TTL/CMOS logic compatible

BENEFITS

- Low signal errors and distortion
- Reduced power supply requirements
- Faster throughput
- Improved reliability
- Reduced pedestal errors
- Simple interfacing

FUNCTIONAL BLOCK DIAGRAM AND PIN CONFIGURATION

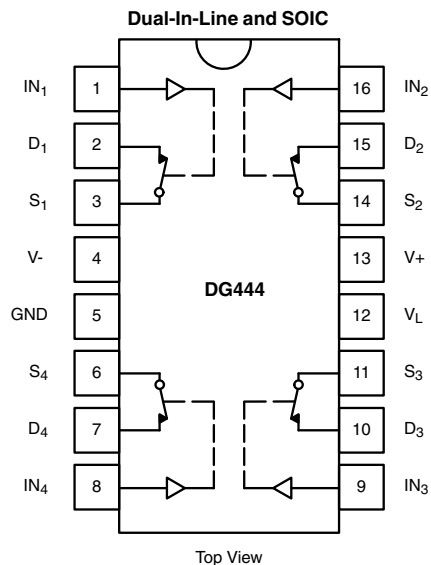

TRUTH TABLE		
Logic	DG444	DG445
0	On	Off
1	Off	On

Logic "0" ≤ 0.8 V
 Logic "1" ≥ 2.4 V

ORDERING INFORMATION		
Temp. Range	Package	Part Number
- 40 °C to 85 °C	16-pin plastic DIP	DG444DJ
		DG445DJ
	16-pin narrow SOIC	DG444DY
		DG445DY



ABSOLUTE MAXIMUM RATINGS ($T_A = 25\text{ }^\circ\text{C}$, unless otherwise noted)			
Parameter		Limit	Unit
V_+ to V_-		44	V
GND to V_-		25	
V_L		(GND - 0.3) to (V_+) + 0.3	
Digital Inputs ^a , V_S , V_D		(V_-) - 2 to (V_+) + 2 or 30 mA, whichever occurs first	
Continuous Current (Any Terminal)		30	mA
Current, S or D (Pulsed at 1 ms, 10 % Duty Cycle)		100	
Storage Temperature		- 65 to 125	$^\circ\text{C}$
Power Dissipation (Package) ^b	16-Pin Plastic DIP ^c	450	mW
	16-Pin Narrow Body SOIC ^d	640	

Notes:

- a. Signals on S_X , D_X , or IN_X exceeding V_+ or V_- will be clamped by internal diodes. Limit forward diode current to maximum current ratings.
- b. All leads welded or soldered to PC board.
- c. Derate 6 mW/ $^\circ\text{C}$ above $75\text{ }^\circ\text{C}$.
- d. Derate 8 mW/ $^\circ\text{C}$ above $75\text{ }^\circ\text{C}$.

SPECIFICATIONS for Dual Supplies								
Parameter	Symbol	Test Conditions Unless Otherwise Specified $V_+ = 15\text{ V}$, $V_- = -15\text{ V}$ $V_L = 5\text{ V}$, $V_{IN} = 2.4\text{ V}$, 0.8 V^e	Temp. ^a	D Suffix - $40\text{ }^\circ\text{C}$ to $85\text{ }^\circ\text{C}$			Unit	
				Min. ^b	Typ. ^c	Max. ^b		
Analog Switch								
Analog Signal Range ^d	V_{ANALOG}		Full	- 15		15	V	
Drain-Source On-Resistance	$R_{DS(on)}$	$I_S = -10\text{ mA}$, $V_D = \pm 8.5\text{ V}$ $V_+ = 13.5\text{ V}$, $V_- = -13.5\text{ V}$	Room Full		50	85 100	Ω	
Switch Off Leakage Current	$I_{S(off)}$	$V_+ = 16.5\text{ V}$, $V_- = -16.5\text{ V}$ $V_D = \pm 15.5\text{ V}$, $V_S = \pm 15.5\text{ V}$	Room Full	- 0.5 - 5	± 0.01	0.5 5	nA	
	$I_{D(off)}$		Room Full	- 0.5 - 5	± 0.01	0.5 5		
Channel On Leakage Current	$I_{D(on)}$	$V_+ = 16.5\text{ V}$, $V_- = -16.5\text{ V}$ $V_S = V_D = \pm 15.5\text{ V}$	Room Full	- 0.5 - 10	± 0.08	0.5 10		
Digital Control								
Input Current V_{IN} Low	I_{IL}	V_{IN} under test = 0.8 V All Other = 2.4 V	Full	- 500	- 0.01	500	nA	
Input Current V_{IN} High	I_{IH}	V_{IN} under test = 2.4 V All Other = 0.8 V	Full	- 500	0.01	500		
Dynamic Characteristics								
Turn-On Time	t_{ON}	$R_L = 1\text{ k}\Omega$, $C_L = 35\text{ pF}$ $V_S = \pm 10\text{ V}$, See Figure 2	Room		120	250	ns	
Turn-Off Time	t_{OFF}		DG444	Room		110		140
			DG445	Room		160		210
Charge Injection ^e	Q	$C_L = 1\text{ nF}$, $V_S = 0\text{ V}$ $V_{gen} = 0\text{ V}$, $R_{gen} = 0\text{ }\Omega$	Room		- 1		pC	
Off Isolation ^e	OIRR	$R_L = 50\text{ }\Omega$, $C_L = 5\text{ pF}$, $f = 1\text{ MHz}$	Room		60		dB	
Crosstalk (Channel-to-Channel) ^d	X_{TALK}		Room		100			
Source Off Capacitance	$C_{S(off)}$	f = 1 MHz	Room		4		pF	
Drain Off Capacitance	$C_{D(off)}$		Room		4			
Channel On Capacitance	$C_{D(on)}$	$V_{ANALOG} = 0\text{ V}$	Room		16			



SPECIFICATIONS for Dual Supplies							
Parameter	Symbol	Test Conditions Unless Otherwise Specified $V_+ = 15\text{ V}$, $V_- = -15\text{ V}$ $V_L = 5\text{ V}$, $V_{IN} = 2.4\text{ V}$, 0.8 V^e	Temp. ^a	D Suffix - 40 °C °C to 85 °C			Unit
				Min. ^b	Typ. ^c	Max. ^b	
Power Supplies							
Positive Supply Current	I+	$V_+ = 16.5\text{ V}$, $V_- = -16.5\text{ V}$ $V_{IN} = 0$ or 5 V	Room Full		0.001	1 5	μA
Negative Supply Current	I-		Room Full	-1 -5	-0.0001		
Logic Supply Current	I _L		Room Full		0.001	1 5	
Ground Current	I _{GND}		Room Full	-1 -5	-0.001		

SPECIFICATIONS for Unipolar Supplies							
Parameter	Symbol	Test Conditions Unless Otherwise Specified $V_+ = 12\text{ V}$, $V_- = 0\text{ V}$ $V_L = 5\text{ V}$, $V_{IN} = 2.4\text{ V}$, 0.8 V^e	Temp. ^a	Limits - 40 °C °C to 85 °C			Unit
				Min. ^b	Typ. ^c	Max. ^b	
Analog Switch							
Analog Signal Range ^d	V _{ANALOG}		Full	0		12	V
Drain-Source On-Resistance ^d	R _{DS(on)}	$I_S = -10\text{ mA}$, $V_D = 3\text{ V}$, 8 V $V_+ = 10.8\text{ V}$, $V_L = 5.25\text{ V}$	Room Full		100	160 200	Ω
Dynamic Characteristics							
Turn-On Time	t _{ON}	$R_L = 1\text{ k}\Omega$, $C_L = 35\text{ pF}$, $V_S = 8\text{ V}$ See Figure 2	Room		300	450	ns
Turn-Off Time	t _{OFF}		Room		60	200	
Charge Injection	Q	$C_L = 1\text{ nF}$, $V_{gen} = 6\text{ V}$, $R_{gen} = 0\ \Omega$	Room		2		pC
Power Supplies							
Positive Supply Current	I+	$V_+ = 13.2\text{ V}$, $V_{IN} = 0$ or 5 V	Room Full		0.001	1 5	μA
Negative Supply Current	I-	$V_{IN} = 0$ or 5 V	Room Full	-1 -5	-0.0001		
Logic Supply Current	I _L	$V_L = 5.25\text{ V}$, $V_{IN} = 0$ or 5 V	Room Full		0.001	1 5	
Ground Current	I _{GND}	$V_{IN} = 0$ or 5 V	Full	-1 -5	-0.001		

Notes:

- a. Room = 25 °C, Full = as determined by the operating temperature suffix.
- b. The algebraic convention whereby the most negative value is a minimum and the most positive a maximum, is used in this datasheet.
- c. Typical values are for DESIGN AID ONLY, not guaranteed nor subject to production testing.
- d. Guaranteed by design, not subject to production test.
- e. V_{IN} = input voltage to perform proper function.

Stresses beyond those listed under "Absolute Maximum Ratings" may cause permanent damage to the device. These are stress ratings only, and functional operation of the device at these or any other conditions beyond those indicated in the operational sections of the specifications is not implied. Exposure to absolute maximum rating conditions for extended periods may affect device reliability.

TYPICAL CHARACTERISTICS (T_A = 25 °C, unless otherwise noted)

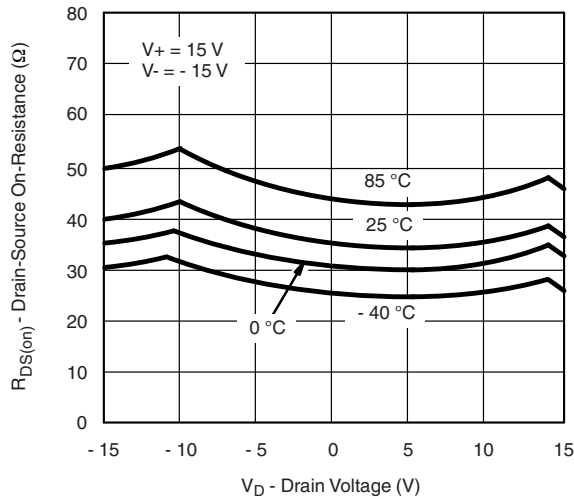

R_{DS(on)} vs. V_D and Temperature

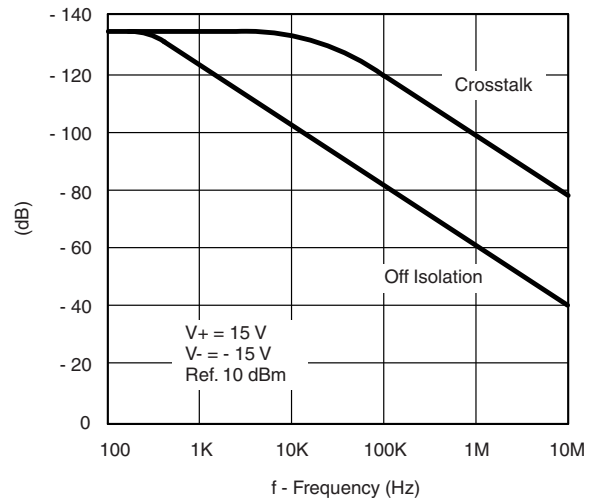

Crosstalk and Off Isolation vs. Frequency

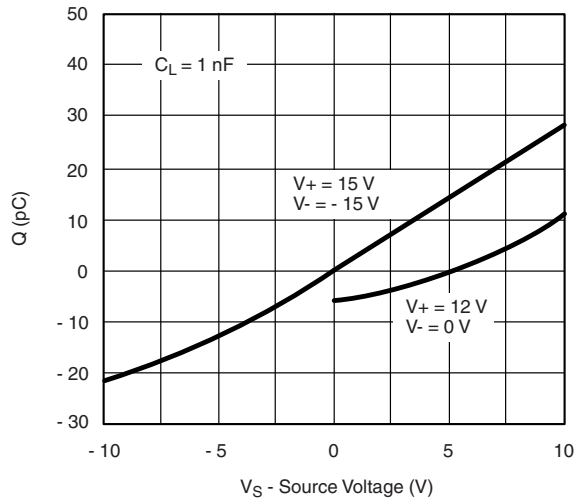

Charge Injection vs. Source Voltage

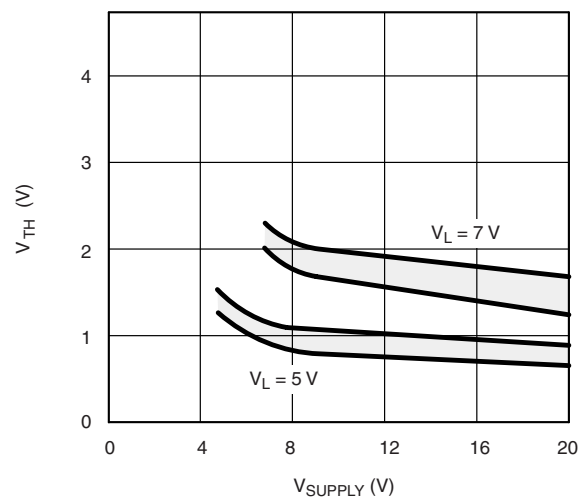

Switching Threshold vs. Supply Voltage

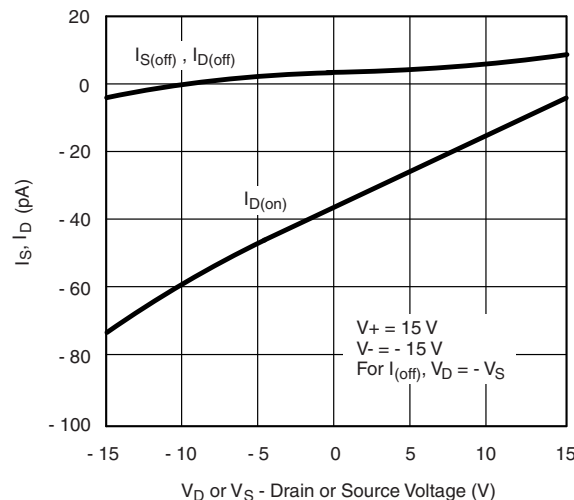

Source/Drain Leakage Currents

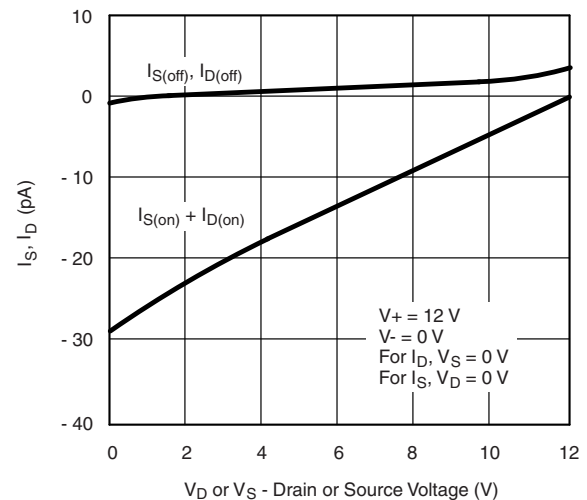

Source/Drain Leakage Currents (Single 12-V Supply)

TYPICAL CHARACTERISTICS ($T_A = 25^\circ\text{C}$, unless otherwise noted)

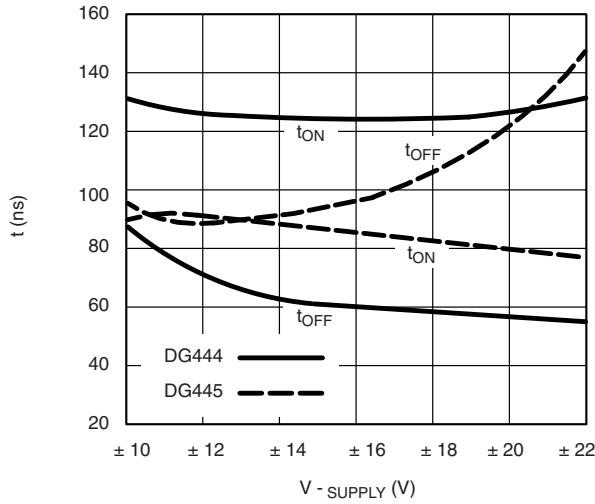

Switching Time vs. Power Supply Voltage

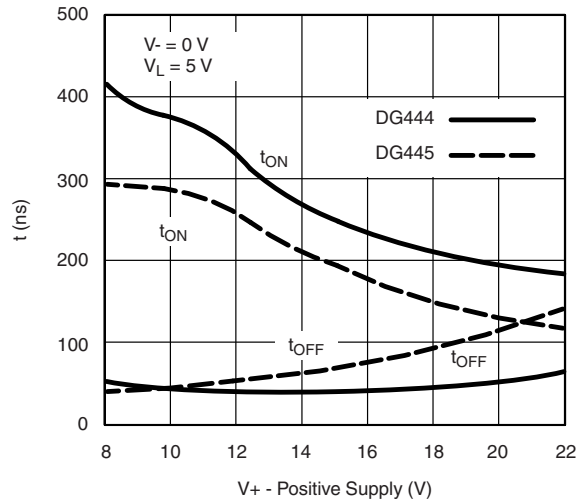

Switching Times vs. Power Supply Voltage

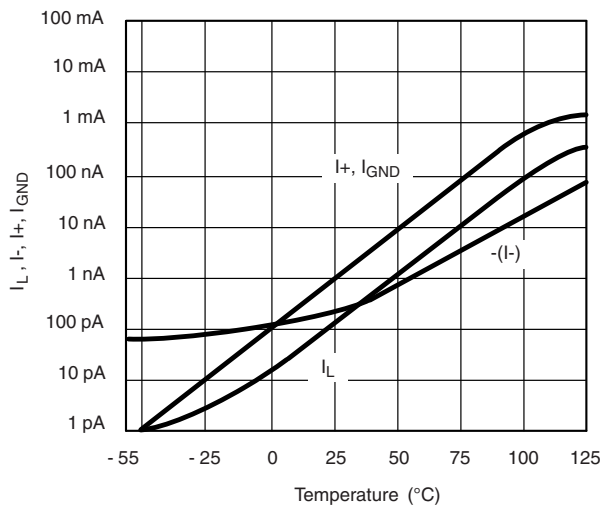

Supply Current vs. Temperature

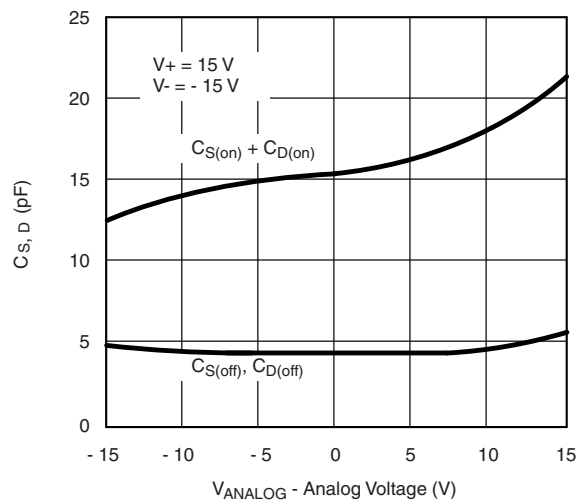

Source/Drain Capacitance vs. Analog Voltage

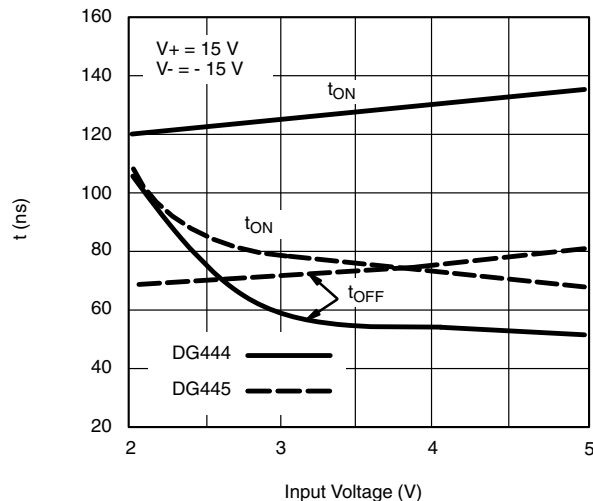

Switching Time vs. Input Voltage

SCHEMATIC DIAGRAM Typical Channel

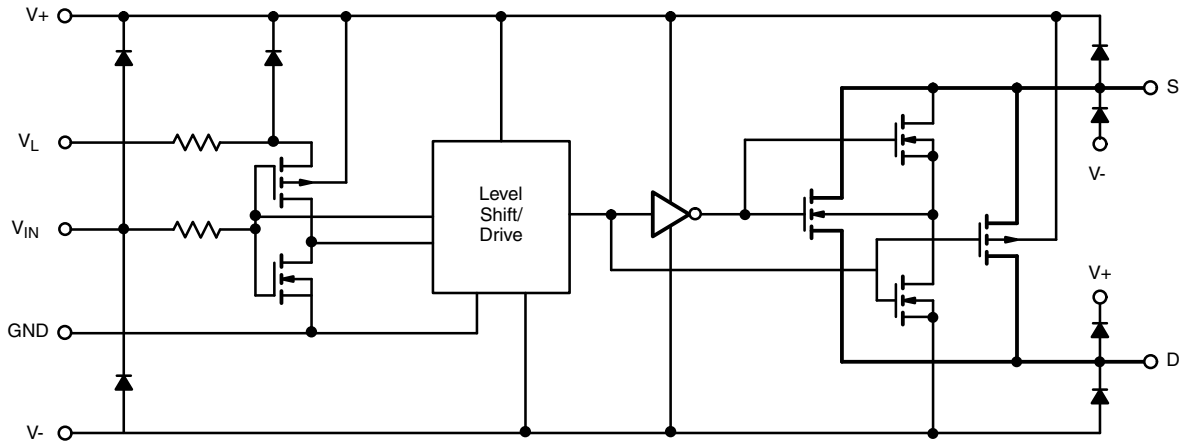
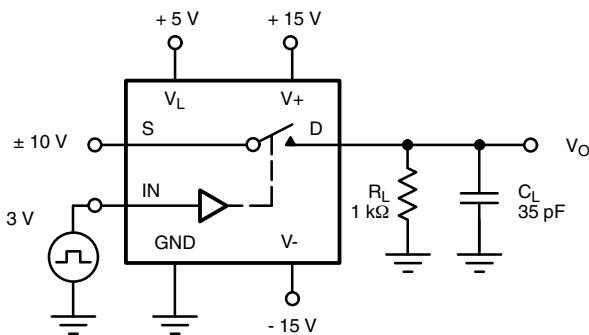
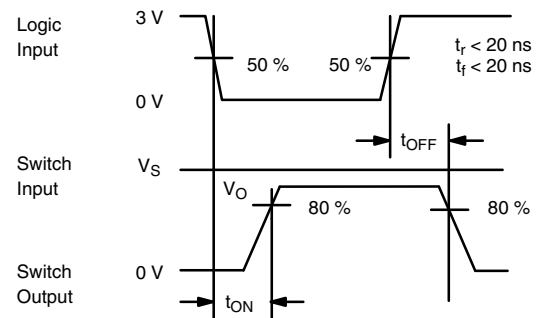

Figure 1.

TEST CIRCUITS



C_L (includes fixture and stray capacitance)



Note: Logic input waveform is inverted for DG445.

Figure 2. Switching Time

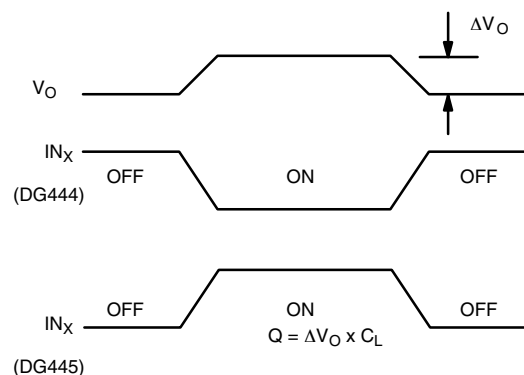
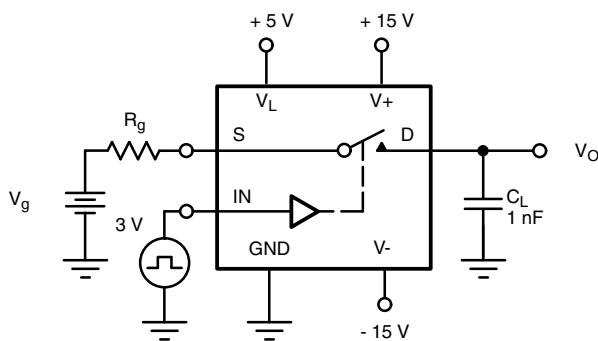

Figure 3. Charge Injection

TEST CIRCUITS

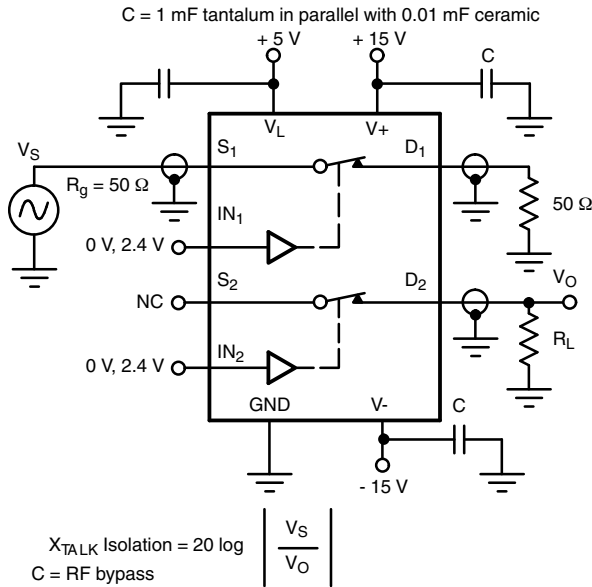

Figure 4. Crosstalk

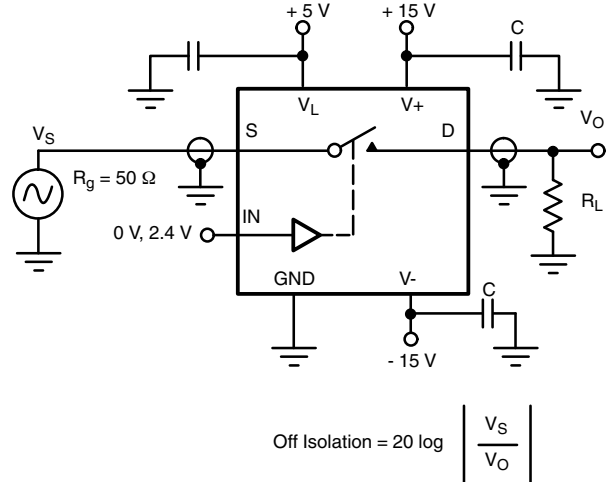

Figure 5. Off Isolation

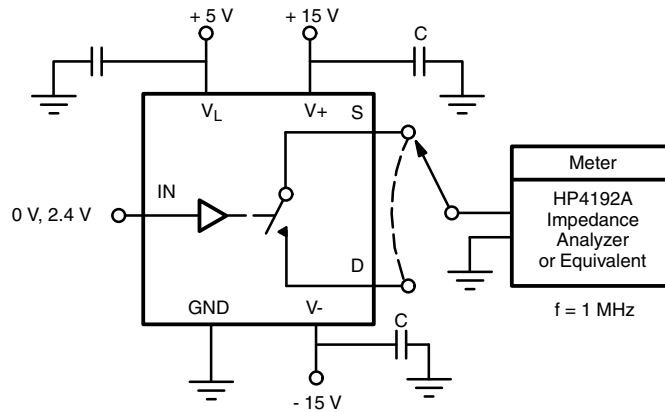

Figure 6. Source/Drain Capacitances

APPLICATIONS

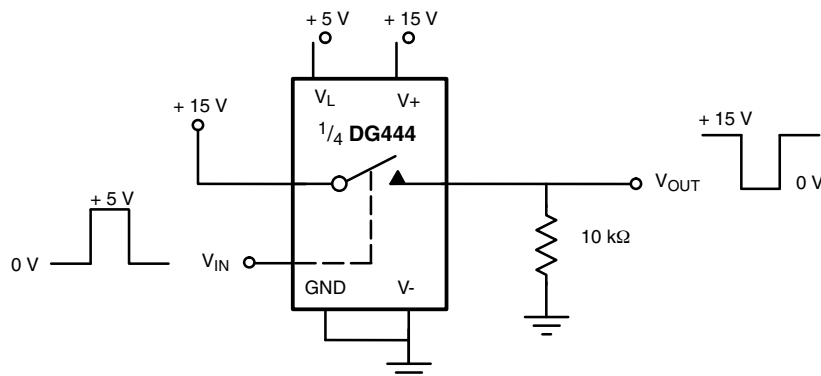

Figure 7. Level Shifter

APPLICATIONS

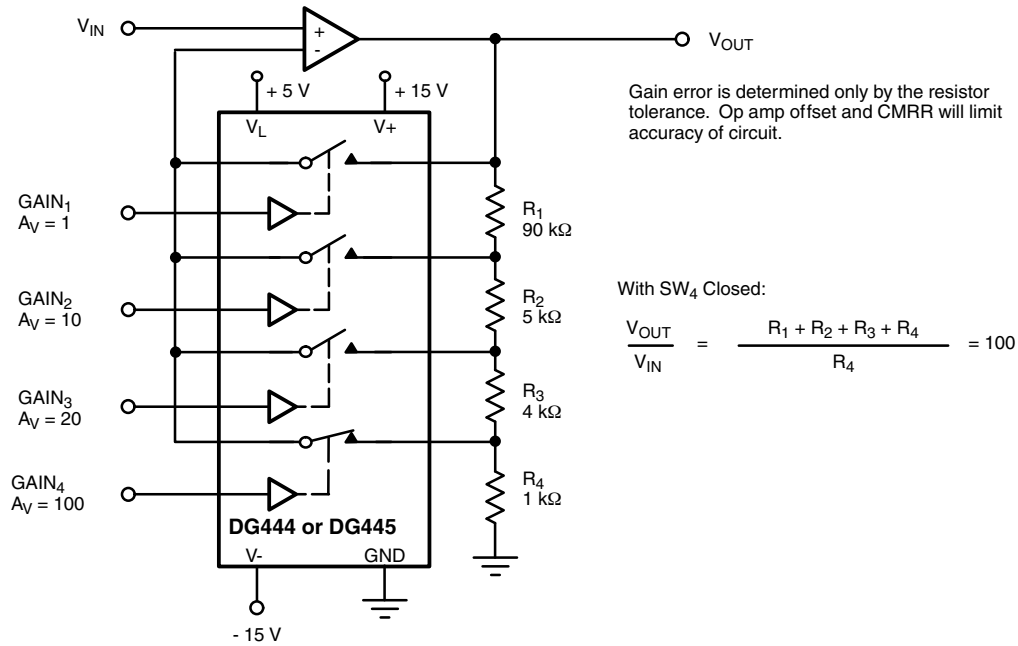

Figure 8. Precision-Weighted Resistor Programmable-Gain Amplifier

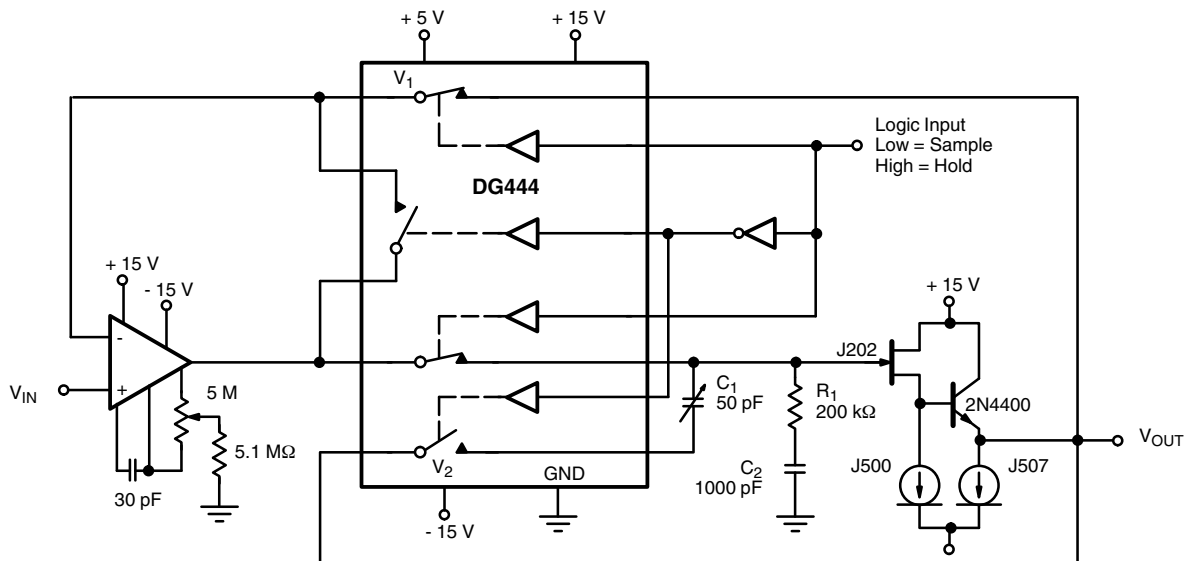

Figure 9. Precision Sample-and-Hold

Vishay Siliconix maintains worldwide manufacturing capability. Products may be manufactured at one of several qualified locations. Reliability data for Silicon Technology and Package Reliability represent a composite of all qualified locations. For related documents such as package/tape drawings, part marking, and reliability data, see www.vishay.com/ppg?70054.



SOIC (NARROW): 16-LEAD
JEDEC Part Number: MS-012



Dim	MILLIMETERS		INCHES	
	Min	Max	Min	Max
A	1.35	1.75	0.053	0.069
A ₁	0.10	0.20	0.004	0.008
B	0.38	0.51	0.015	0.020
C	0.18	0.23	0.007	0.009
D	9.80	10.00	0.385	0.393
E	3.80	4.00	0.149	0.157
e	1.27 BSC		0.050 BSC	
H	5.80	6.20	0.228	0.244
L	0.50	0.93	0.020	0.037
∅	0°	8°	0°	8°

ECN: S-03946—Rev. F, 09-Jul-01
DWG: 5300





PDIP: 16-LEAD



Dim	MILLIMETERS		INCHES	
	Min	Max	Min	Max
A	3.81	5.08	0.150	0.200
A₁	0.38	1.27	0.015	0.050
B	0.38	0.51	0.015	0.020
B₁	0.89	1.65	0.035	0.065
C	0.20	0.30	0.008	0.012
D	18.93	21.33	0.745	0.840
E	7.62	8.26	0.300	0.325
E₁	5.59	7.11	0.220	0.280
e₁	2.29	2.79	0.090	0.110
e_A	7.37	7.87	0.290	0.310
L	2.79	3.81	0.110	0.150
Q₁	1.27	2.03	0.050	0.080
S	0.38	1.52	.015	0.060

ECN: S-03946—Rev. D, 09-Jul-01
DWG: 5482

RECOMMENDED MINIMUM PADS FOR SO-16

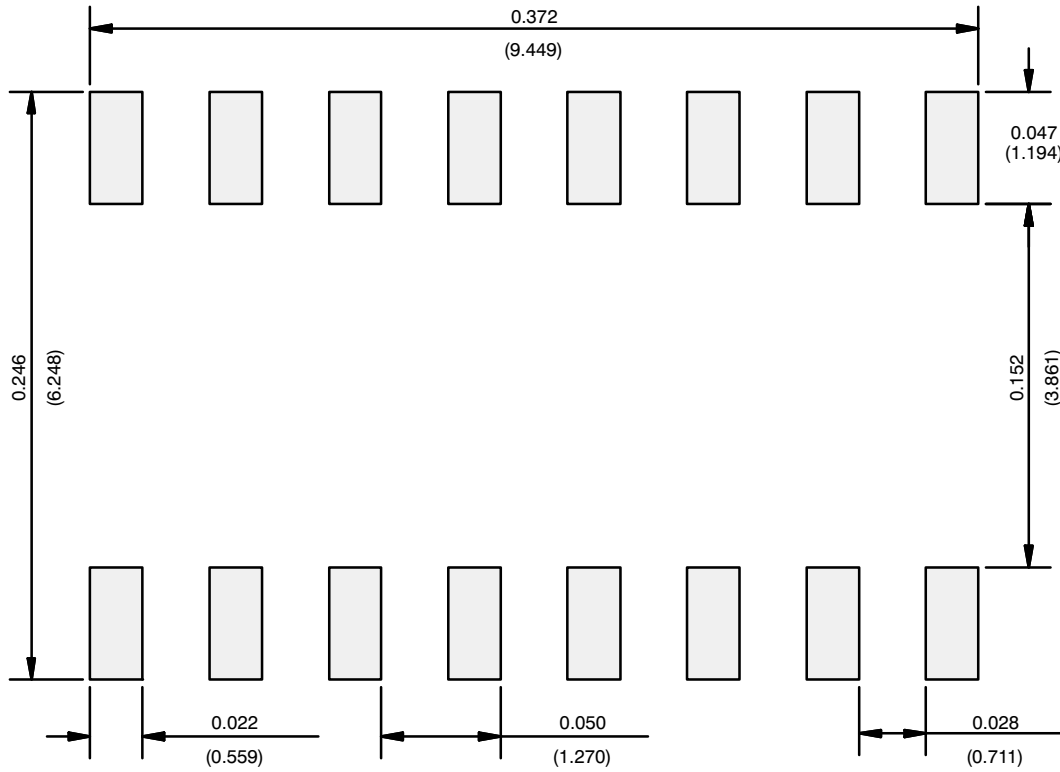

Recommended Minimum Pads
Dimensions in Inches/(mm)

[Return to Index](#)



Disclaimer

ALL PRODUCT, PRODUCT SPECIFICATIONS AND DATA ARE SUBJECT TO CHANGE WITHOUT NOTICE TO IMPROVE RELIABILITY, FUNCTION OR DESIGN OR OTHERWISE.

Vishay Intertechnology, Inc., its affiliates, agents, and employees, and all persons acting on its or their behalf (collectively, "Vishay"), disclaim any and all liability for any errors, inaccuracies or incompleteness contained in any datasheet or in any other disclosure relating to any product.

Vishay makes no warranty, representation or guarantee regarding the suitability of the products for any particular purpose or the continuing production of any product. To the maximum extent permitted by applicable law, Vishay disclaims (i) any and all liability arising out of the application or use of any product, (ii) any and all liability, including without limitation special, consequential or incidental damages, and (iii) any and all implied warranties, including warranties of fitness for particular purpose, non-infringement and merchantability.

Statements regarding the suitability of products for certain types of applications are based on Vishay's knowledge of typical requirements that are often placed on Vishay products in generic applications. Such statements are not binding statements about the suitability of products for a particular application. It is the customer's responsibility to validate that a particular product with the properties described in the product specification is suitable for use in a particular application. Parameters provided in datasheets and/or specifications may vary in different applications and performance may vary over time. All operating parameters, including typical parameters, must be validated for each customer application by the customer's technical experts. Product specifications do not expand or otherwise modify Vishay's terms and conditions of purchase, including but not limited to the warranty expressed therein.

Except as expressly indicated in writing, Vishay products are not designed for use in medical, life-saving, or life-sustaining applications or for any other application in which the failure of the Vishay product could result in personal injury or death. Customers using or selling Vishay products not expressly indicated for use in such applications do so at their own risk. Please contact authorized Vishay personnel to obtain written terms and conditions regarding products designed for such applications.

No license, express or implied, by estoppel or otherwise, to any intellectual property rights is granted by this document or by any conduct of Vishay. Product names and markings noted herein may be trademarks of their respective owners.

Material Category Policy

Vishay Intertechnology, Inc. hereby certifies that all its products that are identified as RoHS-Compliant fulfill the definitions and restrictions defined under Directive 2011/65/EU of The European Parliament and of the Council of June 8, 2011 on the restriction of the use of certain hazardous substances in electrical and electronic equipment (EEE) - recast, unless otherwise specified as non-compliant.

Please note that some Vishay documentation may still make reference to RoHS Directive 2002/95/EC. We confirm that all the products identified as being compliant to Directive 2002/95/EC conform to Directive 2011/65/EU.

Vishay Intertechnology, Inc. hereby certifies that all its products that are identified as Halogen-Free follow Halogen-Free requirements as per JEDEC JS709A standards. Please note that some Vishay documentation may still make reference to the IEC 61249-2-21 definition. We confirm that all the products identified as being compliant to IEC 61249-2-21 conform to JEDEC JS709A standards.



Компания «ЭлектроПласт» предлагает заключение долгосрочных отношений при поставках импортных электронных компонентов на взаимовыгодных условиях!

Наши преимущества:

- Оперативные поставки широкого спектра электронных компонентов отечественного и импортного производства напрямую от производителей и с крупнейших мировых складов;
- Поставка более 17-ти миллионов наименований электронных компонентов;
- Поставка сложных, дефицитных, либо снятых с производства позиций;
- Оперативные сроки поставки под заказ (от 5 рабочих дней);
- Экспресс доставка в любую точку России;
- Техническая поддержка проекта, помощь в подборе аналогов, поставка прототипов;
- Система менеджмента качества сертифицирована по Международному стандарту ISO 9001;
- Лицензия ФСБ на осуществление работ с использованием сведений, составляющих государственную тайну;
- Поставка специализированных компонентов (Xilinx, Altera, Analog Devices, Intersil, Interpoint, Microsemi, Aeroflex, Peregrine, Syfer, Eurofarad, Texas Instrument, Miteq, Cobham, E2V, MA-COM, Hittite, Mini-Circuits, General Dynamics и др.);

Помимо этого, одним из направлений компании «ЭлектроПласт» является направление «Источники питания». Мы предлагаем Вам помощь Конструкторского отдела:

- Подбор оптимального решения, техническое обоснование при выборе компонента;
- Подбор аналогов;
- Консультации по применению компонента;
- Поставка образцов и прототипов;
- Техническая поддержка проекта;
- Защита от снятия компонента с производства.



Как с нами связаться

Телефон: 8 (812) 309 58 32 (многоканальный)

Факс: 8 (812) 320-02-42

Электронная почта: org@eplast1.ru

Адрес: 198099, г. Санкт-Петербург, ул. Калинина, дом 2, корпус 4, литера А.