

ASSR-4110, ASSR-4111, ASSR-4120

General Purpose, Form A, Solid State Relay (Photo MOSFET)

(400V/0.12A/25Ω)



Data Sheet



Description

The ASSR-41xx Series consists of an AlGaAs infrared light-emitting diode (LED) input stage optically coupled to a high-voltage output detector circuit. The detector consists of a high-speed photovoltaic diode array and driver circuitry to switch on/off two discrete high voltage MOSFETs. The relay turns on (contact closes) with a minimum input current of 3mA through the input LED. The relay turns off (contact opens) with an input voltage of 0.8V or less.

The single channel configurations, ASSR-4110 and ASSR-4111, are equivalent to 1 Form A Electromechanical Relays (EMR), and the dual channel configuration, ASSR-4120, are equivalent to 2 Form A EMR. They are available in 4-pin SO, 6-pin DIP, 8-pin DIP and Gull Wing Surface Mount for DIP packages. Their electrical and switching characteristics are specified over the temperature range of -40°C to +85°C. They are used for general purpose switching of signals and low power AC/DC loads.

ASSR-4111 enables AC/DC and DC-only output connections. For DC-only connection, the output current, I_o , increases to 0.24A and the on-resistance, $R_{(ON)}$ reduces to 8.5Ω.

Functional Diagram

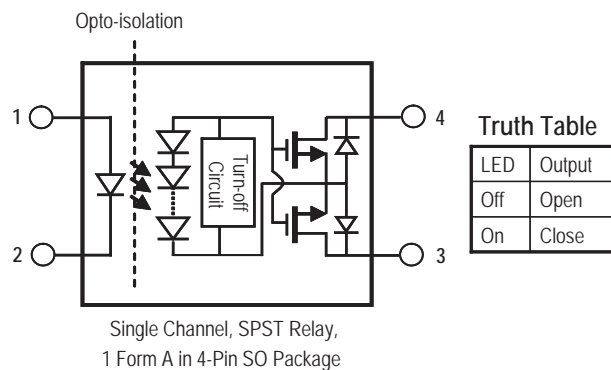

Features

- Compact Solid-State Bi-directional Signal Switch
- Single and Dual Channel Normally-off Single-Pole-Single-Throw (SPST) Relay
- 400V Output Withstand Voltage
- 0.12A or 0.24A Current Rating
(See Schematic for ASSR-4111 Connection A and B)
- Low Input Current: CMOS Compatibility
- Low On-Resistance:
5.5Ω Typical for DC-only, 16Ω Typical for AC/DC
- Very High Output Off-state Impedance:
10 Teraohms Typical
- High Speed Switching:
0.1ms (Ton), 0.02ms (Toff) Typical
- High Transient Immunity: >1kV/μs
- High Input-to-Output Insulation Voltage
(Safety and Regulatory Approvals)
- 3750 Vrms for 1 min per UL1577
- CSA Component Acceptance

Applications

- Telecommunication Switching
- Data Communications
- Industrial Controls
- Medical
- Security
- EMR / Reed Relay Replacement

CAUTION: It is advised that normal static precautions be taken in handling and assembly of this component to prevent damage and/or degradation which may be induced by ESD.

Ordering Information

ASSR-xxxx is UL Recognized with 3750 Vrms for 1 minute per UL1577 and is approved under CSA Component Acceptance Notice #5.

Part number	Option	Package	Surface Mount	Gull Wing	Tape & Reel	Quantity
	RoHS Compliant					
ASSR-4110	-003E	SO-4	X			100 units per tube
	-503E		X		X	1500 units per reel
ASSR-4111	-001E	300mil DIP-6				50 units per tube
	-301E		X	X		50 units per tube
	-501E		X	X	X	1000 units per reel
ASSR-4120	-002E	300 mil DIP-8				50 units per tube
	-302E		X	X		50 units per tube
	-502E		X	X	X	1000 units per reel

To order see attached table, choose a part number from the part number column and combine with the desired option from the option column to form an order entry.

Example 1:

ASSR-4111-501E to order product of 300mil DIP-6 Gull Wing Surface Mount package in Tape and Reel packaging and RoHS Compliant.

Example 2:

ASSR-4120-002E to order product of 300mil DIP-8 package in tube packaging and RoHS Compliant.

Option datasheets are available. Contact your Avago sales representative or authorized distributor for information.

Schematic

ASSR-4110



ASSR-4111 Connection A

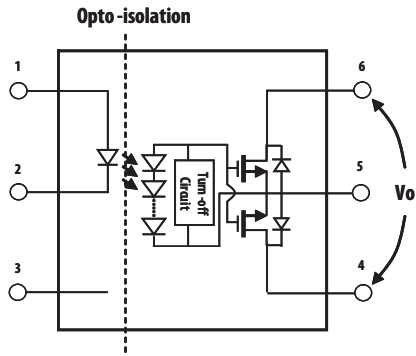

Equivalent Relay Diagram

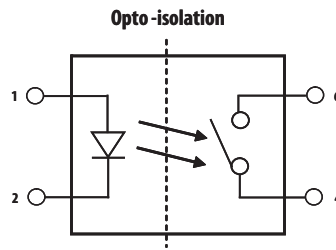

ASSR-4111 Connection B

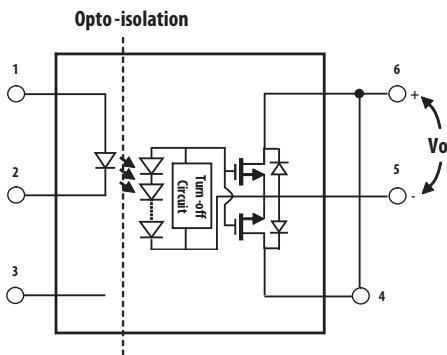

Equivalent Relay Diagram

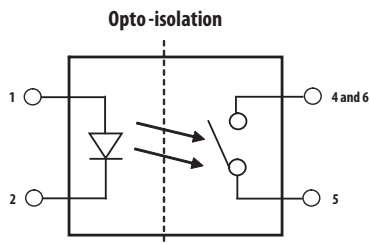

ASSR-4120

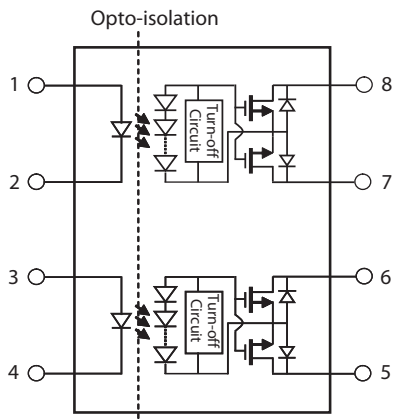

Equivalent Relay Diagram

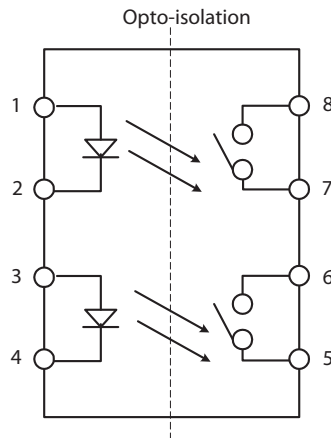

Package Outline Drawings

ASSR-4110 4-Pin Small Outline Package

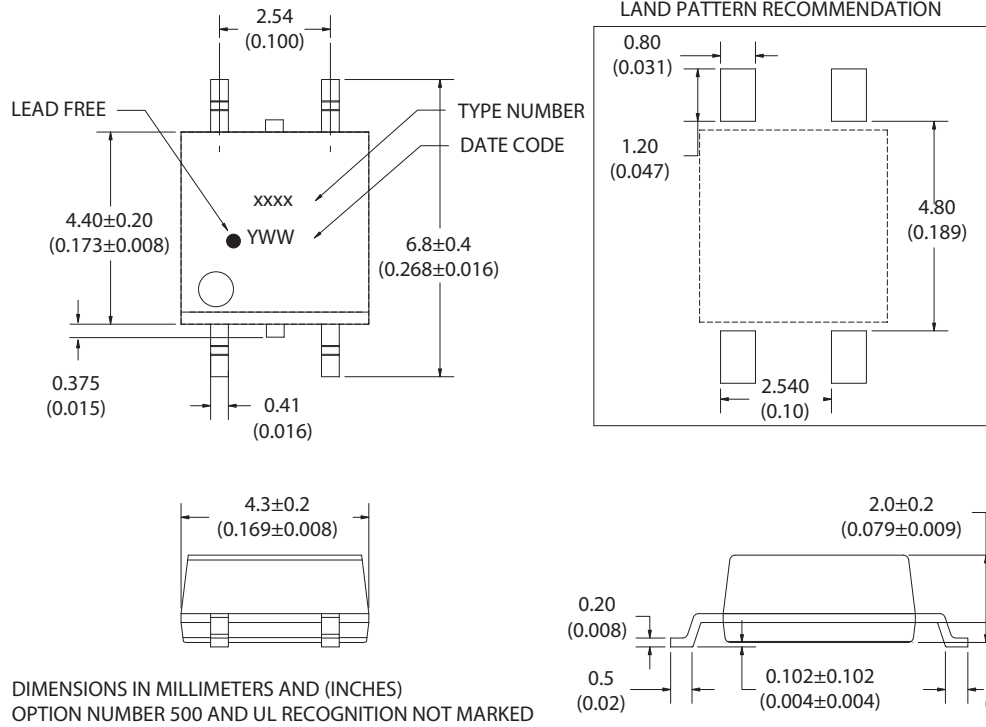

ASSR-4111 6-Pin DIP Package

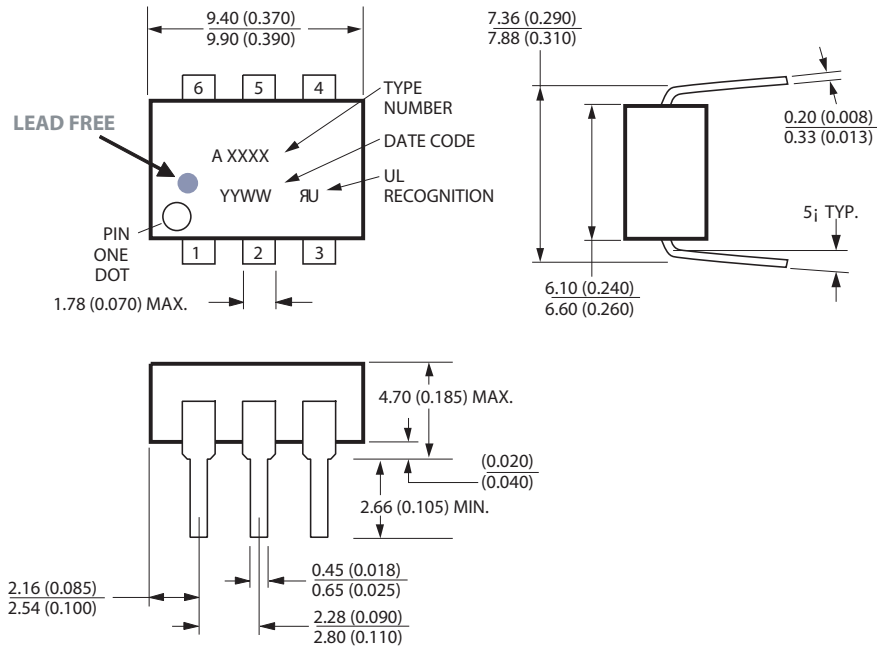

ASSR-4111 6-Pin DIP Package with Gull Wing Surface Mount Option 300



NOTE: FLOATING LEAD PROTRUSION IS 0.25 mm (10 mils) MAX.

ASSR-4120 8-Pin DIP Package

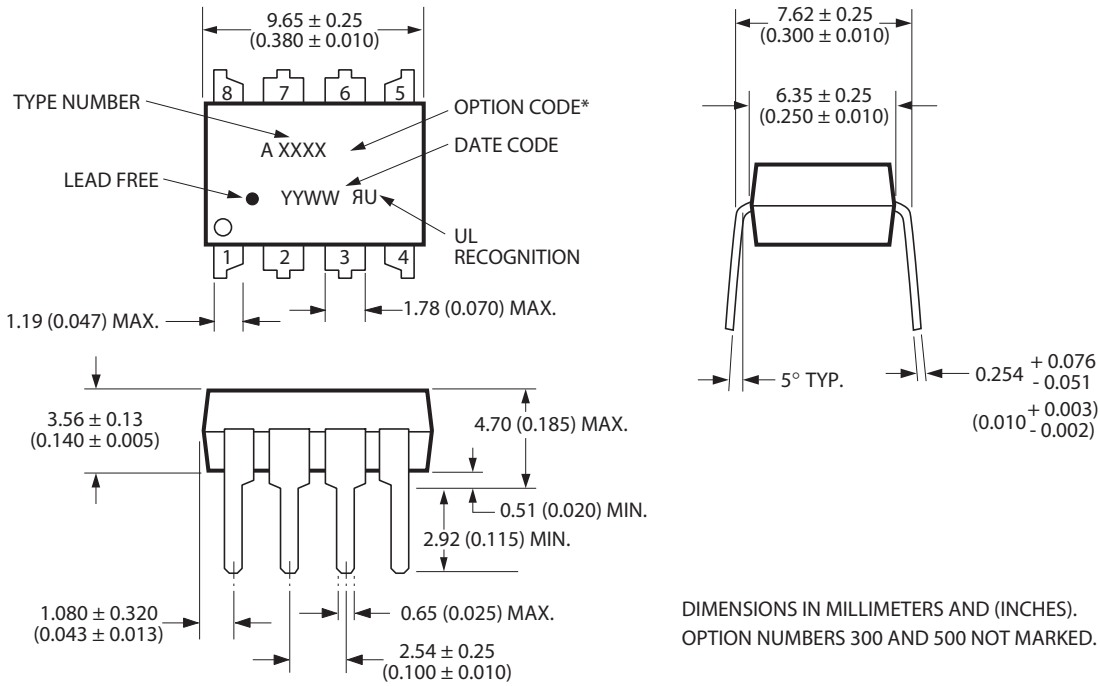

DIMENSIONS IN MILLIMETERS AND (INCHES).
OPTION NUMBERS 300 AND 500 NOT MARKED.

ASSR-4120 8-Pin DIP Package with Gull Wing Surface Mount Option 300

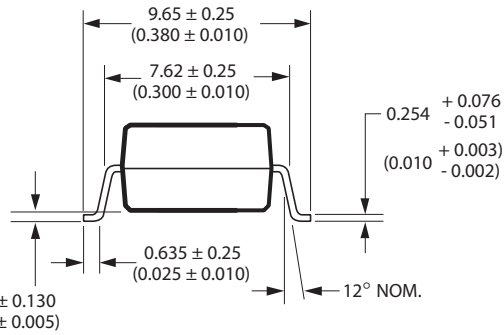
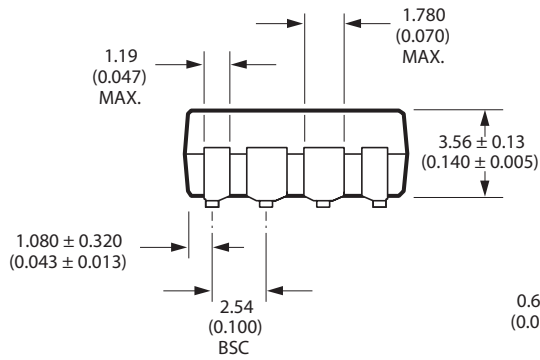
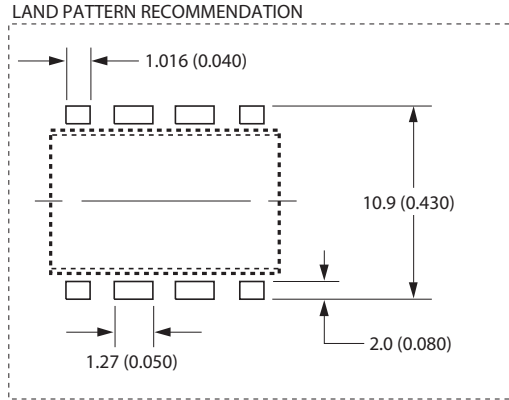
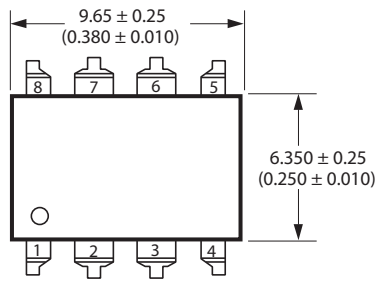

DIMENSIONS IN MILLIMETERS (INCHES).
LEAD COPLANARITY = 0.10 mm (0.004 INCHES).

NOTE: FLOATING LEAD PROTRUSION IS 0.25 mm (10 mils) MAX.

Lead Free IR Profile

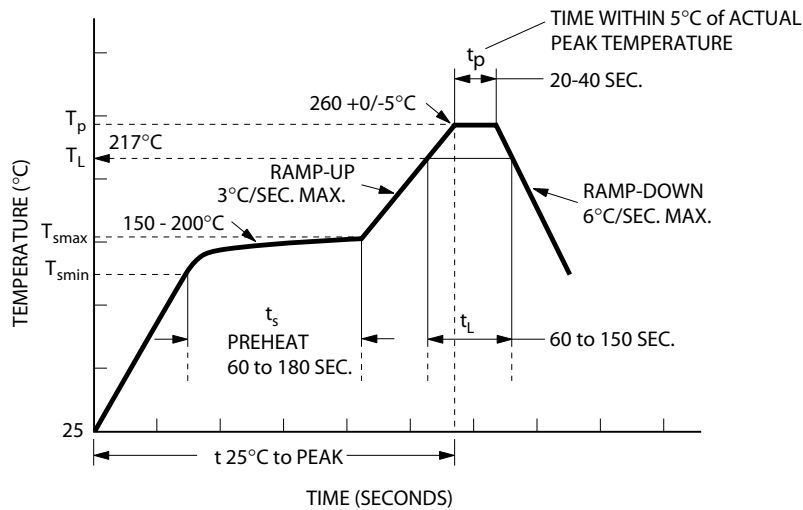

NOTES:
 THE TIME FROM 25°C TO PEAK TEMPERATURE = 8 MINUTES MAX.
 $T_{smax} = 200°C$, $T_{smin} = 150°C$

Non-halide flux should be used.

Regulatory Information

The ASSR-4110, ASSR-4111 and ASSR-4120 are approved by the following organizations:

UL

Approved under UL 1577, component recognition program up to $V_{ISO} = 3750 V_{RMS}$

CSA

Approved under CSA Component Acceptance Notice #5.

Insulation and Safety Related Specifications

Parameter	Symbol	ASSR-4110	ASSR-4111 ASSR-4120	Units	Conditions
Minimum External Air Gap (Clearance)	L(101)	4.9	7.1	mm	Measured from input terminals to output terminals, shortest distance through air.
Minimum External Tracking (Creepage)	L(102)	4.9	7.4	mm	Measured from input terminals to output terminals, shortest distance path along body.
Minimum Internal Plastic Gap (Internal Clearance)		0.08	0.08	mm	Through insulation distance conductor to conductor, usually the straight line distance thickness between the emitter and detector.
Tracking Resistance (Comparative Tracking Index)	CTI	175	175	V	DIN IEC 112/VDE 0303 Part 1
Isolation Group (DIN VDE0109)		IIIa	IIIa		Material Group (DIN VDE 0109)

Absolute Maximum Ratings

Parameter	Symbol	Min.	Max.	Units	Note	
Storage Temperature	T_S	-55	125	°C		
Operating Temperature	T_A	-40	85	°C		
Junction Temperature	T_J		125	°C		
Lead Soldering Cycle	Temperature		260	°C		
	Time		10	s		
Input Current	Average	I_F	25	mA		
	Surge		50			
	Transient		1000			
Reversed Input Voltage	V_R		5	V		
Input Power Dissipation	ASSR-4110	P_{IN}	40	mW		
	ASSR-4111	P_{IN}	40	mW		
	ASSR-4120	P_{IN}	80	mW		
Output Power Dissipation	ASSR-4110	P_O	360	mW		
	ASSR-4111	P_O	490	mW		
	ASSR-4120	P_O	720	mW		
Average Output Current ($T_A = 25^\circ\text{C}$, $T_C \leq 100^\circ\text{C}$)		I_O	0.12	A	1	
	ASSR-4111 Connection B		0.24	A		
Output Voltage ($T_A = 25^\circ\text{C}$)		V_O	-400	400	V	2
	ASSR-4111 Connection B		0	400	V	
Solder Reflow Temperature Profile	See Lead Free IR Profile					

Recommended Operating Conditions

Parameter	Symbol	Min.	Max.	Units	Note
Input Current (ON)	$I_{F(ON)}$	3	20	mA	3
Input Voltage (OFF)	$V_{F(OFF)}$	0	0.8	V	
Operating Temperature	T_A	-40	+85	°C	

Package Characteristics

Unless otherwise specified, $T_A = 25^\circ\text{C}$.

Parameter	Sym.	Min.	Typ.	Max.	Units	Conditions	Note
Input-Output Momentary Withstand Voltage	V_{ISO}	3750			Vrms	$RH \leq 50\%$, $t = 1 \text{ min}$	4, 5
Input-Output Resistance	R_{I-O}		10^{12}		Ω	$V_{I-O} = 500 \text{ Vdc}$	
Input-Output Capacitance	ASSR-4110 C_{I-O}		0.4		pF	$f = 1 \text{ MHz}$; $V_{I-O} = 0 \text{ Vdc}$	4
	ASSR-4111 C_{I-O}		0.5		pF	$f = 1 \text{ MHz}$; $V_{I-O} = 0 \text{ Vdc}$	
	ASSR-4120 C_{I-O}		0.8		pF	$f = 1 \text{ MHz}$; $V_{I-O} = 0 \text{ Vdc}$	

Electrical Specifications (DC)

Over recommended operating $T_A = -40^\circ\text{C}$ to 85°C , $I_F = 5 \text{ mA}$ to 10 mA , unless otherwise specified.

Parameter	Sym.	Min.	Typ.	Max.	Units	Conditions	Fig.	Note
Output Withstand Voltage	$ V_{O(OFF)} $	400	450		V	$V_F = 0.8 \text{ V}$, $I_O = 250 \mu\text{A}$, $T_A = 25^\circ\text{C}$		
		360			V	$V_F = 0.8 \text{ V}$, $I_O = 250 \mu\text{A}$	5	
Output Leakage Current	$I_{O(OFF)}$		0.5	100	nA	$V_F = 0.8 \text{ V}$, $V_O = 400 \text{ V}$, $T_A = 25^\circ\text{C}$		
				1	μA	$V_F = 0.8 \text{ V}$, $V_O = 400 \text{ V}$	6	
Output Offset Voltage	$ V_{(OS)} $		1		μV	$I_F = 5 \text{ mA}$, $I_O = 0 \text{ mA}$		
Input Reverse Breakdown Voltage	V_R	5			V	$I_R = 10 \mu\text{A}$		
Input Forward Voltage	V_F	1.1	1.3	1.65	V	$I_F = 5 \text{ mA}$	7, 8	
Output On-resistance	$R_{(ON)}$		16	25	Ω	$I_F = 5 \text{ mA}$, $I_O = 120 \text{ mA}$, Pulse $\leq 30 \text{ ms}$, $T_A = 25^\circ\text{C}$	9, 10	6
	ASSR-4111 Connection B		5.5	8.5	Ω	$I_F = 5 \text{ mA}$, $I_O = 240 \text{ mA}$, Pulse $\leq 30 \text{ ms}$, $T_A = 25^\circ\text{C}$		

Switching Specifications (AC)

Over recommended operating $T_A = -40^\circ\text{C}$ to 85°C , $I_F = 5\text{ mA}$ to 10 mA , unless otherwise specified.

Parameter	Sym.	Min.	Typ.	Max.	Units	Conditions	Fig.	Note
Turn On Time	T_{ON}		0.25	0.5	ms	$I_F = 5\text{ mA}$, $I_O = 120\text{ mA}$, $T_A = 25^\circ\text{C}$	11, 15	
				1.0	ms	$I_F = 5\text{ mA}$, $I_O = 120\text{ mA}$	12	
			0.1	0.25	ms	$I_F = 10\text{ mA}$, $I_O = 120\text{ mA}$, $T_A = 25^\circ\text{C}$		
				0.5	ms	$I_F = 10\text{ mA}$, $I_O = 120\text{ mA}$		
Turn Off Time	T_{OFF}		0.02	0.2	ms	$I_F = 5\text{ mA}$, $I_O = 120\text{ mA}$, $T_A = 25^\circ\text{C}$	13, 15	
				0.5	ms	$I_F = 5\text{ mA}$, $I_O = 120\text{ mA}$	14	
			0.02	0.15	ms	$I_F = 10\text{ mA}$, $I_O = 120\text{ mA}$, $T_A = 25^\circ\text{C}$		
				0.2	ms	$I_F = 10\text{ mA}$, $I_O = 120\text{ mA}$		
Output Transient Rejection	dV_O/dt	1	7		kV/ μs	$\Delta V_O = 400\text{ V}$, $T_A = 25^\circ\text{C}$	16	
Input-Output Transient Rejection	dV_{I-O}/dt	1	≥ 10		kV/ μs	$\Delta V_{I-O} = 1000\text{ V}$, $T_A = 25^\circ\text{C}$	17	

Notes:

- For derating, refer to Figure 1, 2, 3 and 4.
- The voltage across the output terminals of the relay should not exceed this rated withstand voltage. Over-voltage protection circuits should be added in some applications to protect against over-voltage transients.
- Threshold to switch device is $I_F \geq 0.5\text{ mA}$, however, for qualified device performance over temperature range, it is recommended to operate at $I_F = 5\text{ mA}$.
- Device is considered as a two terminal device:
 - ASSR-4110 - pin 1, 2 shorted and pin 3, 4 shorted.
 - ASSR-4111 - pin 1, 2, 3 shorted and pin 4, 5, 6 shorted.
 - ASSR-4120 - pin 1, 2, 3, 4 shorted and pin 5, 6, 7, 8 shorted.
- The Input-Output Momentary Withstand Voltage is a dielectric voltage rating that should not be interpreted as an input-output continuous voltage rating. For the continuous voltage rating refer to the IEC/EN/DIN EN 60747-5-2 Insulation Characteristics Table (if applicable), your equipment level safety specification, or Avago Technologies Application Note 1074, "Optocoupler Input-Output Endurance Voltage."
- During the pulsed $R_{(ON)}$ measurement (I_O duration $\leq 30\text{ ms}$), ambient (T_A) and case temperature (T_C) are equal.

Applications Information

On-Resistance and Derating Curves

The Output On-Resistance, $R_{(ON)}$, specified in this data sheet, is the resistance measured across the output contact when a pulsed current signal ($I_o = 120 \text{ mA}$) is applied to the output pins. The use of a pulsed signal ($\leq 30 \text{ ms}$) implies that each junction temperature is equal to the ambient and case temperatures. The steady-state resistance, R_{ss} , on the other hand, is the value of the resistance measured across the output contact when a DC current signal is applied to the output pins for a duration sufficient to reach thermal equilibrium. R_{ss} includes the effects of the temperature rise in the device.

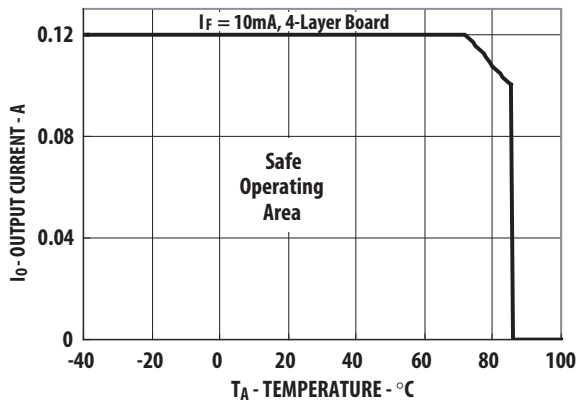

Figure 1. Maximum Output Current Rating vs Ambient Temperature (ASSR-4110-003E)

Figure 1, 2, 3 and 4 specify the maximum average output current allowable for a given ambient temperature. The maximum allowable output current and power dissipation are related by the expression $R_{ss} = P_o(\max)/(I_o(\max))^2$ from which R_{ss} can be calculated. Staying within the safe area assures that the steady state MOSFET junction temperature remains less than 125°C.

Turn On Time and Turn Off Time Variation

The ASSR-41xx Series exhibits a very fast turn on and turn off time. Both the turn on and turn off time can be adjusted by choosing proper forward current as depicted in Figures 11 and 13. The changes of the turn on and turn off time with ambient temperature are also shown in Figures 12 and 14.

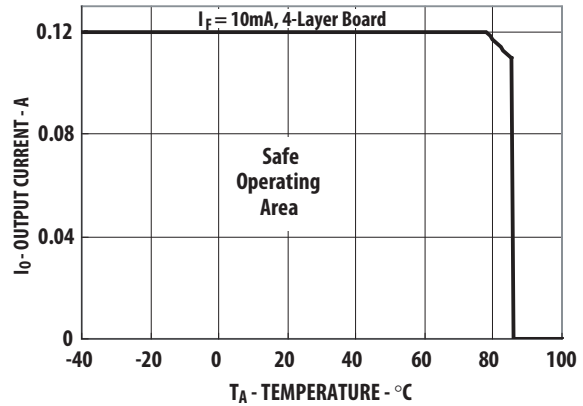

Figure 2. Maximum Output Current Rating vs Ambient Temperature (ASSR-4111-001E)

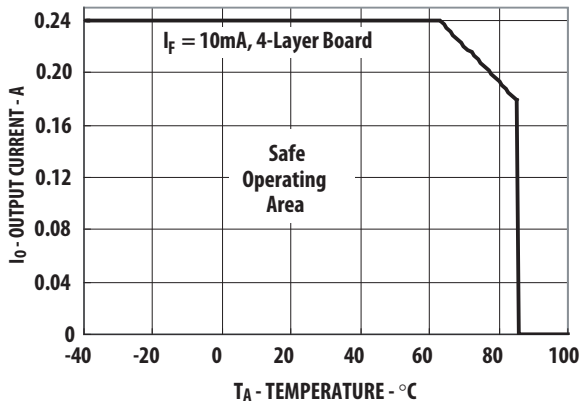

Figure 3. Maximum Output Current Rating vs Ambient Temperature (ASSR-4111-001E) DC Connection

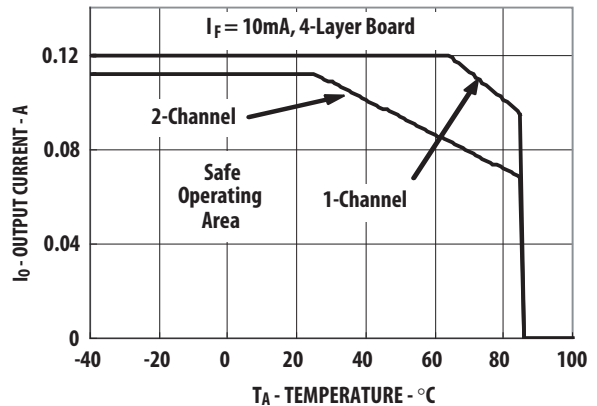

Figure 4. Maximum Output Current Rating vs Ambient Temperature, ASSR-4120-002E



Figure 5. Normalized Typical Output Withstand Voltage vs. Temperature

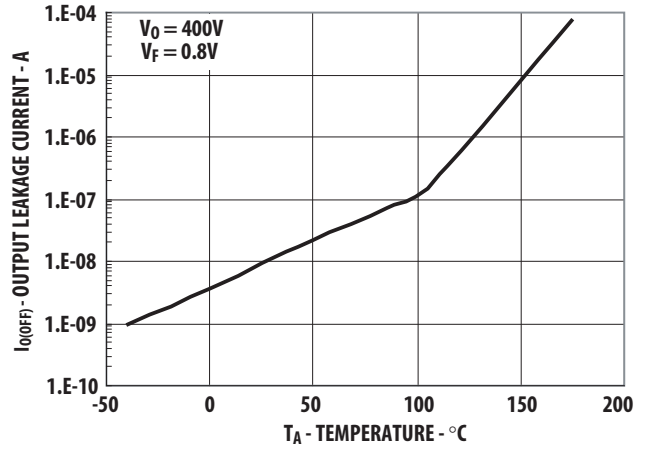

Figure 6. Typical Output Leakage Current vs. Temperature

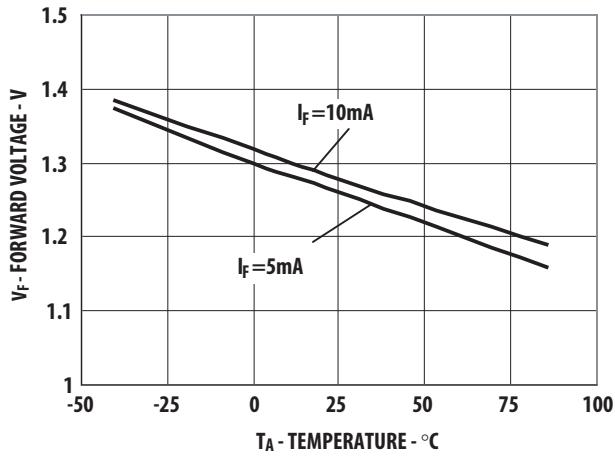

Figure 7. Typical Forward Voltage vs. Temperature

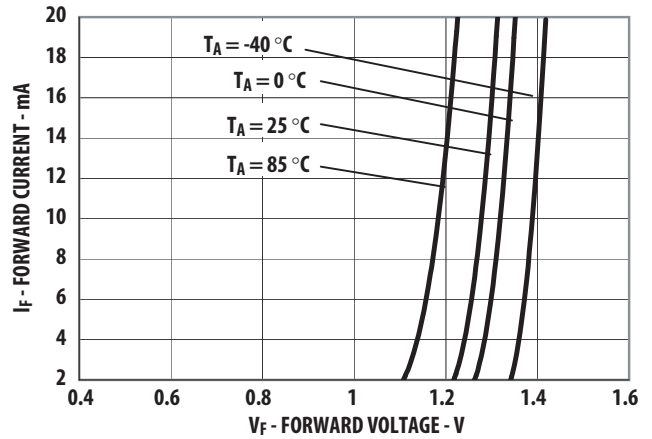

Figure 8. Typical Forward Current vs. Forward Voltage



Figure 9. Typical On Resistance vs. Temperature



Figure 10. Typical Output Current vs. Output Voltage



Figure 11. Typical Turn On Time vs. Input Current

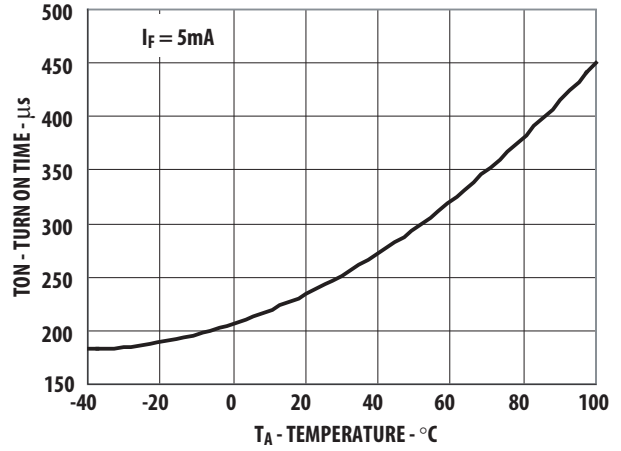

Figure 12. Typical Turn On Time vs. Temperature



Figure 13. Typical Turn Off Time vs. Input Current

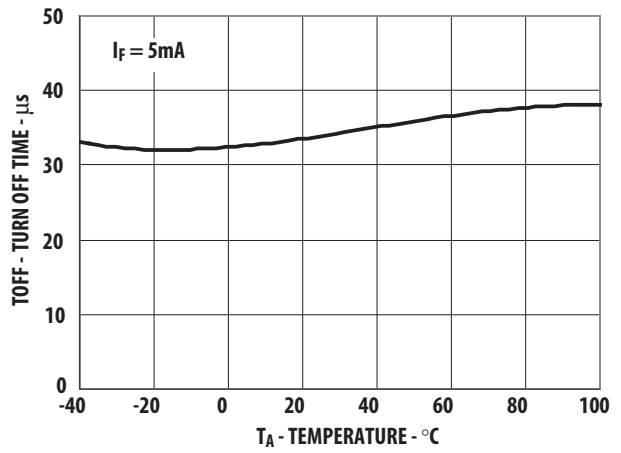

Figure 14. Typical Turn Off Time vs. Temperature



Figure 15. Typical Output Off-State Capacitance vs Output Voltage

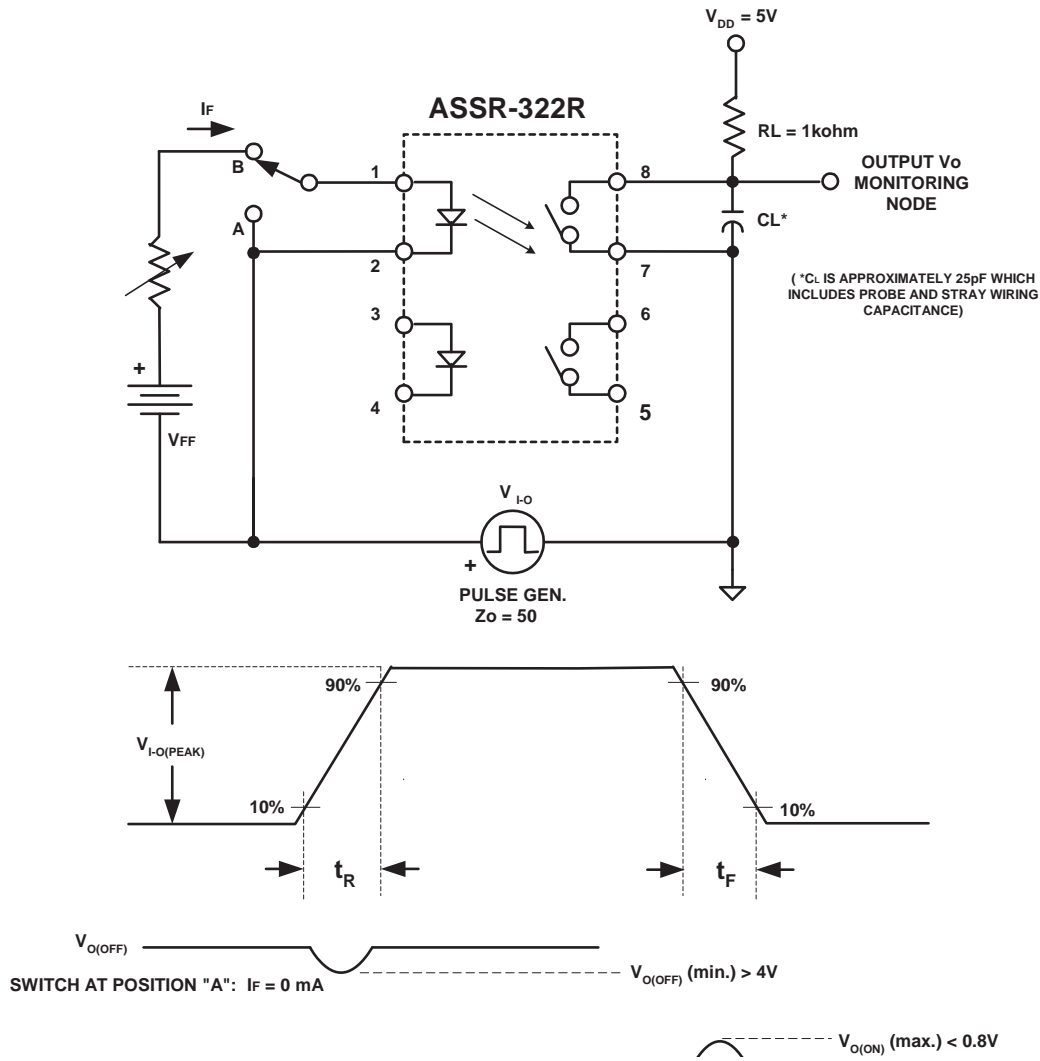
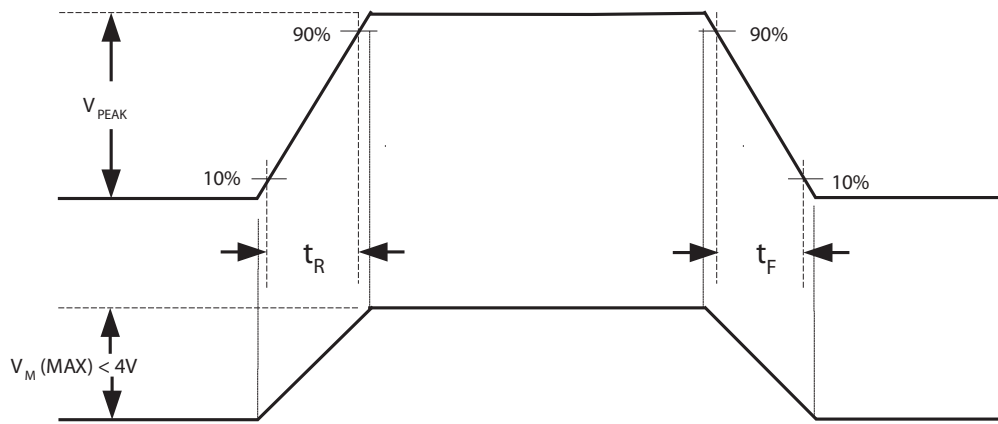

Figure 16. Switching Test circuit for t_{ON} , t_{OFF}



$$\frac{dV_o}{dt} = \frac{(0.8)V_{PEAK}}{t_R} \text{ OR } \frac{(0.8)V_{PEAK}}{t_F}$$

OVERSHOOT ON V_{PEAK} IS TO BE $\leq 10\%$

Figure 17. Output Transient Rejection Test Circuit

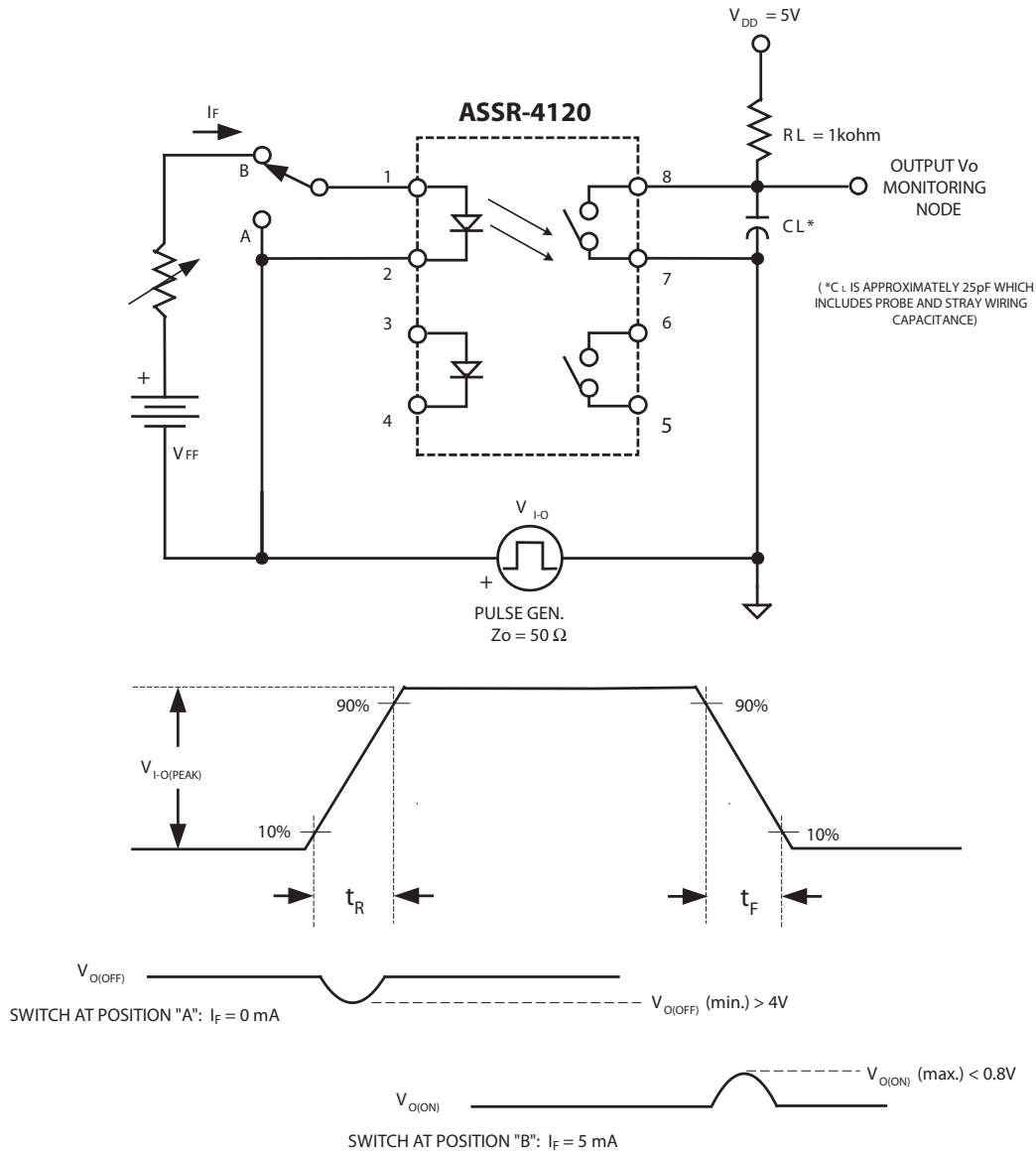

Figure 18. Input - Output Transient Rejection Test Circuit

For product information and a complete list of distributors, please go to our web site: www.avagotech.com

Avago, Avago Technologies, and the A logo are trademarks of Avago Technologies in the United States and other countries. Data subject to change. Copyright © 2005-2012 Avago Technologies. All rights reserved. Obsoletes AV01-0618EN AV02-0279EN - March 19, 2012





Компания «ЭлектроПласт» предлагает заключение долгосрочных отношений при поставках импортных электронных компонентов на взаимовыгодных условиях!

Наши преимущества:

- Оперативные поставки широкого спектра электронных компонентов отечественного и импортного производства напрямую от производителей и с крупнейших мировых складов;
- Поставка более 17-ти миллионов наименований электронных компонентов;
- Поставка сложных, дефицитных, либо снятых с производства позиций;
- Оперативные сроки поставки под заказ (от 5 рабочих дней);
- Экспресс доставка в любую точку России;
- Техническая поддержка проекта, помощь в подборе аналогов, поставка прототипов;
- Система менеджмента качества сертифицирована по Международному стандарту ISO 9001;
- Лицензия ФСБ на осуществление работ с использованием сведений, составляющих государственную тайну;
- Поставка специализированных компонентов (Xilinx, Altera, Analog Devices, Intersil, Interpoint, Microsemi, Aeroflex, Peregrine, Syfer, Eurofarad, Texas Instrument, Miteq, Cobham, E2V, MA-COM, Hittite, Mini-Circuits, General Dynamics и др.);

Помимо этого, одним из направлений компании «ЭлектроПласт» является направление «Источники питания». Мы предлагаем Вам помощь Конструкторского отдела:

- Подбор оптимального решения, техническое обоснование при выборе компонента;
- Подбор аналогов;
- Консультации по применению компонента;
- Поставка образцов и прототипов;
- Техническая поддержка проекта;
- Защита от снятия компонента с производства.



Как с нами связаться

Телефон: 8 (812) 309 58 32 (многоканальный)

Факс: 8 (812) 320-02-42

Электронная почта: org@eplast1.ru

Адрес: 198099, г. Санкт-Петербург, ул. Калинина, дом 2, корпус 4, литера А.