

## GFR4000 Continuous On and Off-Line Monitor



The GFR 4000 ground fault relay is specifically designed to provide complete motor protection without the problems associated with high sensitivity nuisance tripping. The GFR 4000 is unique because it has predictive as well as protective capabilities. The unit operates continuously in one of two modes, either on-line or off-line. The GFR4000 has metering output signals for use with a remote meter or PLC so that ground faults may be detected at an early stage.

The GFR 4000 operates on grounded, high resistance grounded and ungrounded systems. The unit can be directly connected to supplies up to 1300V, 1PH or 3 PH, 50-60 HZ. For supplies from 1300 V to 5000 V, the GFR 4000 must be connected to the HTC 5000 high tension coupling unit.

### Operation

**On-Line Mode** Under normal running conditions the GFR 4000 operates as a sensitive ground fault relay working in conjunction with a separately connected core balance current transformer. The alarm range is adjustable with a 10 position range of fixed operating points between 10 mA and 3A. Time delay is adjustable between 0 and 1 seconds. When the preset response value is exceeded, the GFR4000 operates the output relay after the preset time delay. There is instant LED indication. The unit can be set for Active or Failsafe mode and has memory and auto reset facilities. The GFR 4000 also monitors the loop connection to the current transformer and provides LED indication should it detect a C.T. fault. The metering output signal is proportional to the actual leakage current and is expressed as a percentage of the GFR 4000 leakage current setting. The output is 0 – 1mA FSD with the meter reading scaled 0 to 100% relating directly to the selected current trip value.

**Off-Line Mode** The GFR4000 automatically changes state by means of a small auxiliary contact on the main contactor when the motor (or load) is switched off. The unit becomes a high performance insulation resistance monitor. It imposes a small DC current onto the network which travels through the motor windings and interconnecting cable from the motor starter. A green LED indicates that the off-line monitoring function is active. The insulation resistance function of the GFR has an adjustable alarm range from 250 k $\Omega$  – 2 M $\Omega$ . The red LED indicates “low resistance” and operates instantly when the trip relay is activated. The off-line feature also has an Active/Failsafe Mode and Memory/Auto Reset facilities. The metering output is 0-1mA FSD and relates to an insulation range of 0 to infinity.

### WKE Series Current Transformer

The WKE series C.T.s are specifically designed to operate with POWR-GARD relays. These C.T.s are protected from open circuit burnout and will saturate at low voltages to prevent damage to the C.T. There are varying diameters of C.T. s ranging from 1” to 8 ¼ “. The C.T. is connected across terminals 16 and 17. It is essential when installing C.T.s that only the load cable conductors L and N (1 PH) or L1, L2, and L3 with N (3 ph or 3 or 4 wire), are passed through the center of the C.T. The ground wire must remain outside the C.T. core.

### Features/Benefits

- Adjustable sensitivity from 10 mA t to 3.0 A to reduce nuisance trips.
- Precise insulation resistance readings indicate problems in advance
- Adjustable time delay adapts to unique applications.
- Fail-safe operation
- On Line monitoring of ground to detect any change in leakage current
- Off line monitoring of insulation resistance to notify or halt unacceptable levels
- C.T. Loop Monitoring
- Test/Reset buttons to assure operation
- NO/NC form “C” output alarm relay contacts

# Ground Fault Relays



Expertise Applied | Answers Delivered

## Specifications

Nominal AC Insulation Voltage	660 V AC
Insulation Ground to UL 1053 IEC1010 and VDE 0110	Class C
Test Voltage	1000 V AC
Operation Class	Continuous
Supply voltage Vs	24/115 V ac 50-60 Hz
Power Input	5 V A
Alarm Relay Contacts	2 volt-free NO/NC
Switching capacity	1200VA
Rated Contact voltage	250V
Continuous Current	5 A
Breaking Capacity	
@ 240V AC P.F. = 0.4	3 A
@ 110VDC, @L/R = 0	0.3 A
Relay Function Selection	by linked terminals
Adjustable Function	Failsafe/Active
Relay Alarm Memory	Hand/Auto Reset
Factory Settings	Failsafe/Hand
Operating Ambient Temp.	-10 to +60 deg. C
Storage Ambient Temp.	-40 to +80 dec. C
Mounting	
Terminal Screws	M2.5
Terminal Capacity	0.5 to 2.5 mm <sup>2</sup>
Weight	12 oz
Enclosure	3 15/16"W x 2 15/16 H x4 3/8" D
On-Line Current Relay	10/30/60/80/100/
Response Range	300/800mA, 1/3 A
4 step time delay	0 /.25/.5 / 1 sec.
Metering driver	0 – 1mA FSD
	1 volt-free NO/NC contact
Off-Line Monitor Max	
Voltage for :	
Direct Connection	1300V
With HTC 5000	5000V
Measuring Voltage	12 V DC
Measuring Current	20 uA
DC Internal Resistance	600 KΩ
AC impedance at 50-60 Hz	>1MΩ
Response adjustment pot	250kΩ – 2MΩ
Response delay	<250mSec
Max leakage capacitance to ground	< 1 uF
Max . Stray DC voltage permissible	1000V DC
K.Ω Meter Driver	0 – 1mA FSD
Alarm Relay Contacts	1 volt-free NO/NC Contact
Current Transformer	
C.T. Type	WKE
Burden in GFR4000	ac impedance, 50-60 Hz 150Ω- 1 KΩ

### Supply Voltage and Test

The GFR4000 will operate on supply voltages of 115 V ac or 24V ac, 50-60 Hz(+/- 15%). The green "ON" LED indicates power present. The Test button will test both leakage current and insulation resistance regardless of operation mode. Depress test button for at least 5 secs. to complete test. All LEDs will operate and relay contacts will change to fault/alarm position. If the relay is set to memorize faults, these will remain. Allow 5 seconds before operating the Reset pushbutton. External test/reset facilities via S6/S7 as shown in the Connection Diagram.

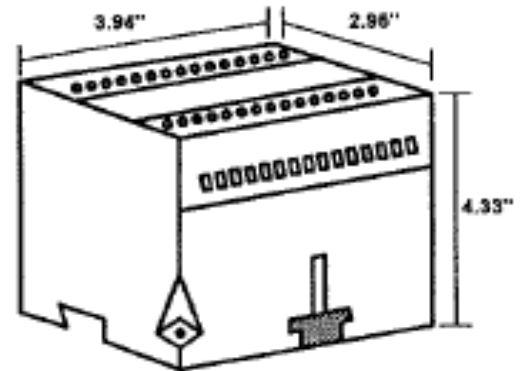

### Warning!

**Before carrying out Megger test or voltage pressure test on the system, be sure to disconnect the GFR4000.**

**It is essential that the connection to ground from terminal 30 is securely connected.**

**When commissioning the installation, always check the relay performance by using a real fault to ground (a 10kΩ resistor rated at 20 watts in a 3ph 660V network will produce approximately 40mA of leakage current and indicate a 10kΩ fault).**

## Legend

- H1 LED green power "ON"
- H2 LED red leakage current "GROUND FAULT"
- H3 LED red open C.T. Circuit "FAULT"
- H4 LED green insulation resistance monitor "ACTIVE"
- H5 LED red low insulation "FAULT"
- S1 Test button for general test
- S3 Leakage current response selector switch
- S4 Leakage current response time delay
- S5 Pushbutton "RESET"
- S6 External test button (not included)
- S7 External reset button (not included)
- R1 Insulation resistance response potentiometer
- K1 Insulation resistance alarm relay
- K2 Leakage current alarm relay
- I External meter for leakage current (not included)
- R External meter for insulation resistance (not included)
- C.T. Current transformer WKE
- HTC High Tension coupler for connections above 1300V ac

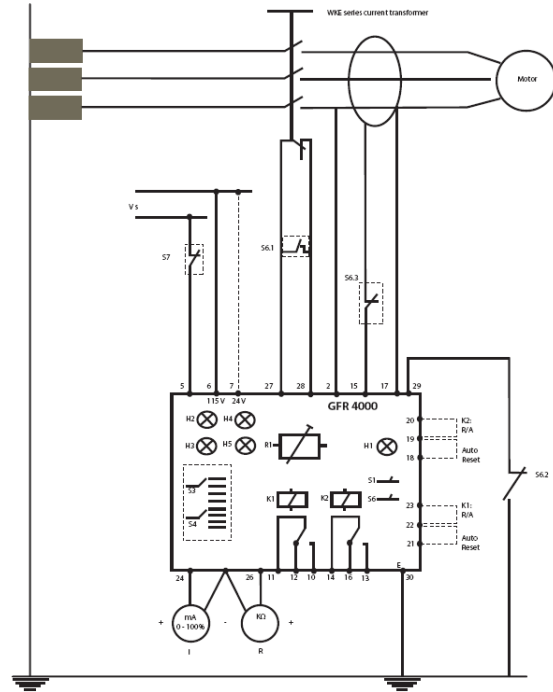

## Terminals

- 2 Coupling for insulation resistance monitoring mode
- 5 – 6 115 V ac power supply (+/- 15%)
- 5 – 7 24 V ac power supply (+/- 15%)
- 10-11-12 Contact relay K1
- 13-14-15 Contact relay K2
- 16 – 17 C.T. connection
- 18 – 19 Link for auto reset K2
- 19 – 20 Link for active mode K2
- 21 – 22 Link for auto reset K1
- 22 – 23 Link for active mode K1
- 24 – 25 Leakage current meter
- 25 – 26 Insulation resistance meter
- 27 – 28 Link for active mode for insulation resistance monitor
- 29 Coupling for HTC 5000/8000
- 30 Measuring ground

\*\* All external switches are shown as optional

### NOTE:

Electronic terminals (16 – 30) are potential free.  
Terminal 30 and Terminal E must be connected to ground!

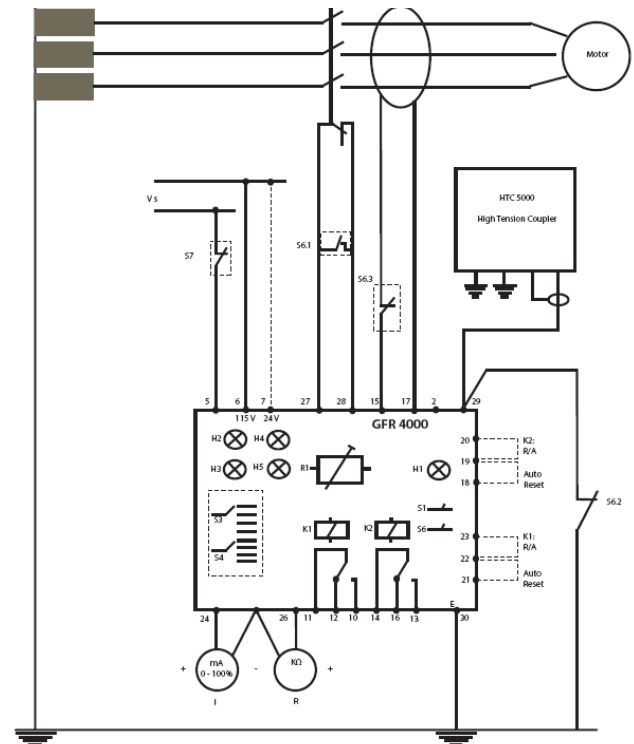

## WKE Series Current Transformers

The WKE Series of current transformers is a key component of the POWR-GARD ground fault detection product line. These CTs are highly accurate. They convert very small differential currents to an ac voltage and output this signal to the connected POWR-GARD ground fault relay. The WKE Series CTs are made from high-density mu metal which has unique and repeatable output characteristics.

### Features

The WKE CTs have built-in safety features far surpassing those of CTs with a ferrite core. The WKE CT is resistant to open circuit burn out and will saturate at safe, low-level voltages. The CTs are housed with an insulating protection. They have built in brackets to facilitate mounting. Terminal cover may be wire sealed for further protection

<b>Primary Current</b>	<b>2500A</b>
<b>Secondary Current</b>	<b>350mA</b>
<b>NSV</b>	<b>600Vac</b>
<b>BIL Rating</b>	<b>2000V</b>
<b>Rated Frequency</b>	<b>10 – 1000Hz</b>
<b>Thermal current rating</b>	<b>70° C</b>
<b>No Fixed Burden</b>	
<b>Accuracy</b>	<b>99%</b>
<b>Flux Shielding</b>	

### Installation Instructions

When installing the WKE CTs, ensure the following:

1. Only the load carrying conductors pass through the center of the CT. (This means L1 + N for 1 phase and L1+ L2 + L3 for 3 phases.)
2. The power conductors pass through the center of the CT and are preferably bound together to keep the conductors uniformly spaced.
3. The power conductors pass PERPENDICULAR to the CT and, whenever practical, continue perpendicular to the CT on both sides of the CT for 3".
4. The power conductors should not be installed in a way that allows them to run along the side edges of the CT.
5. Whenever practical, locate the CT away from noise-generating devices such as transformers, frequency converters, etc.

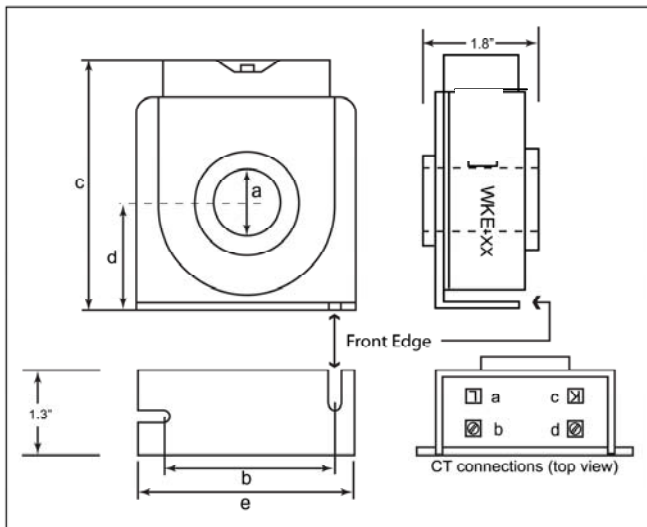

### Dimensions (in)

	a	b	c	d	e
<b>WKE 25</b>	1	3	3.9	1.63	3.63
<b>WKE 60</b>	2.36	3.9	5.25	2.37	4.50
<b>WKE 95</b>	3.74	5.5	6.9	3.25	6.25
<b>WKE130</b>	5.12	7.25	8.5	4	7.0
<b>WKE 200</b>	8.0	10.4	12.1	6.0	11.4



Компания «ЭлектроПласт» предлагает заключение долгосрочных отношений при поставках импортных электронных компонентов на взаимовыгодных условиях!

Наши преимущества:

- Оперативные поставки широкого спектра электронных компонентов отечественного и импортного производства напрямую от производителей и с крупнейших мировых складов;
- Поставка более 17-ти миллионов наименований электронных компонентов;
- Поставка сложных, дефицитных, либо снятых с производства позиций;
- Оперативные сроки поставки под заказ (от 5 рабочих дней);
- Экспресс доставка в любую точку России;
- Техническая поддержка проекта, помощь в подборе аналогов, поставка прототипов;
- Система менеджмента качества сертифицирована по Международному стандарту ISO 9001;
- Лицензия ФСБ на осуществление работ с использованием сведений, составляющих государственную тайну;
- Поставка специализированных компонентов (Xilinx, Altera, Analog Devices, Intersil, Interpoint, Microsemi, Aeroflex, Peregrine, Syfer, Eurofarad, Texas Instrument, Miteq, Cobham, E2V, MA-COM, Hittite, Mini-Circuits, General Dynamics и др.);

Помимо этого, одним из направлений компании «ЭлектроПласт» является направление «Источники питания». Мы предлагаем Вам помощь Конструкторского отдела:

- Подбор оптимального решения, техническое обоснование при выборе компонента;
- Подбор аналогов;
- Консультации по применению компонента;
- Поставка образцов и прототипов;
- Техническая поддержка проекта;
- Защита от снятия компонента с производства.



#### Как с нами связаться

**Телефон:** 8 (812) 309 58 32 (многоканальный)

**Факс:** 8 (812) 320-02-42

**Электронная почта:** [org@eplast1.ru](mailto:org@eplast1.ru)

**Адрес:** 198099, г. Санкт-Петербург, ул. Калинина, дом 2, корпус 4, литера А.