

ASSEMBLY PART NUMBER CHART

PART NUMBERS					KEY OPTION	COMPONENTS				
DELPHI	REV	MVL	REV	INSULATOR (HOUSING)		TPA	RING SEAL	CPA		
13791661	01	F258300	A	A	SS46300	PA66 GF35	COLOR	PA66 GF35	SILICONE	PA66 GF35
33513145	01	F593500	A	A		DK GREY	F055000	F546000 GREEN	NO	F752210 RED
13856436	01	F358300	A	B		AQUA	F643500			
33513146	01	F832210	A	C		NATURAL	F138400			
33513147	01	F932210	A	D		DK GREY	S632210			
13962796	02	F731210	B	A		BLACK	S732210			
33513148	02	F007400	B	B		BLACK	F055000			
33513149	02	F242210	B	C		DK GREY	F366000			
33513150	02	F342210	B	D		DK BLUE	S632210			
						BLACK	S732210			

APPLICABLE COMPONENTS CHART

ITEM NO.	DESCRIPTION	PLATING OR COLOR	SUPPLIER		DELPHI NUMBER	GRIP CODE	WIRE SIZE	WIRE INSULATION DIAMETER RANGE	MATERIAL/SPEC. NO.
			NAME	NUMBER					
5	2.8mm SEALED SYSTEM TERMINAL (F)	TIN	MVL	54001807	10810375	18	20-18 AWG 0.50-1.00mm ²	1.40mm-2.13mm	COPPER ALLOY / NA
	2.8mm SEALED SYSTEM TERMINAL (F)	TIN	MVL	54001404	13627267	14	16-14 AWG 1.50-2.50mm ²	2.18mm-3.00mm	COPPER ALLOY / NA
	2.8mm SEALED SYSTEM TERMINAL (F)	GOLD	MVL	54001811	13948955	18AU	20-18 AWG 0.50-1.00mm ²	1.40mm-2.13mm	COPPER ALLOY / NA
	2.8mm SEALED SYSTEM TERMINAL (F)	GOLD	MVL	54001410	15470590	14AU	16-14 AWG 1.50-2.50mm ²	2.18mm-3.00mm	COPPER ALLOY / NA
6	2.80mm SYSTEM CABLE SEAL ROUND	GREEN	MVL (QSR)	F676000	13791654		20-18 AWG 0.50-1.00mm ²	1.40mm-2.13mm	SILICONE
	2.80mm SYSTEM CABLE SEAL ROUND	BLUE	MVL (QSR)	F576000	13948585		16-14 AWG 1.50-2.00mm ²	2.18mm-2.80mm	SILICONE
	2.80mm SYSTEM CABLE SEAL ROUND	YELLOW	MVL	60994034	10779161		2.5mm ²	2.70mm-3.00mm	SILICONE
7	2.80 SYSTEM CAVITY PLUG ROUND	WHITE	DELPHI	-	15305170		OPTIONAL AS REQUIRED		SILICONE

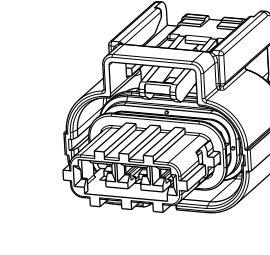

SCALE 1:1

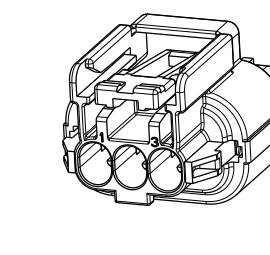

SCALE 1:1

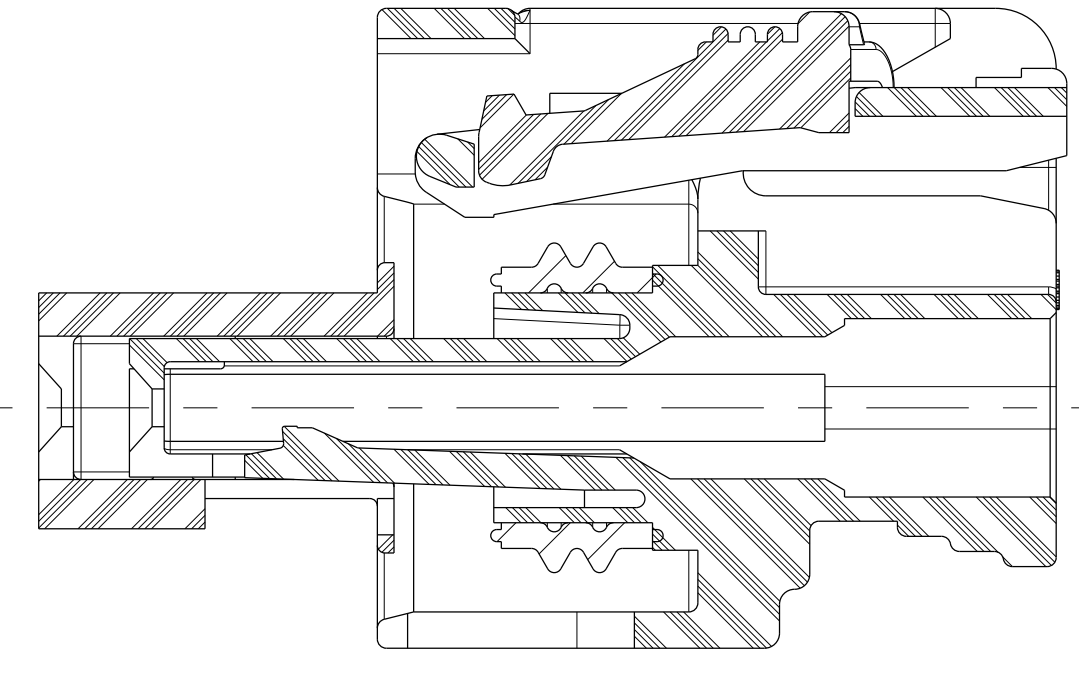
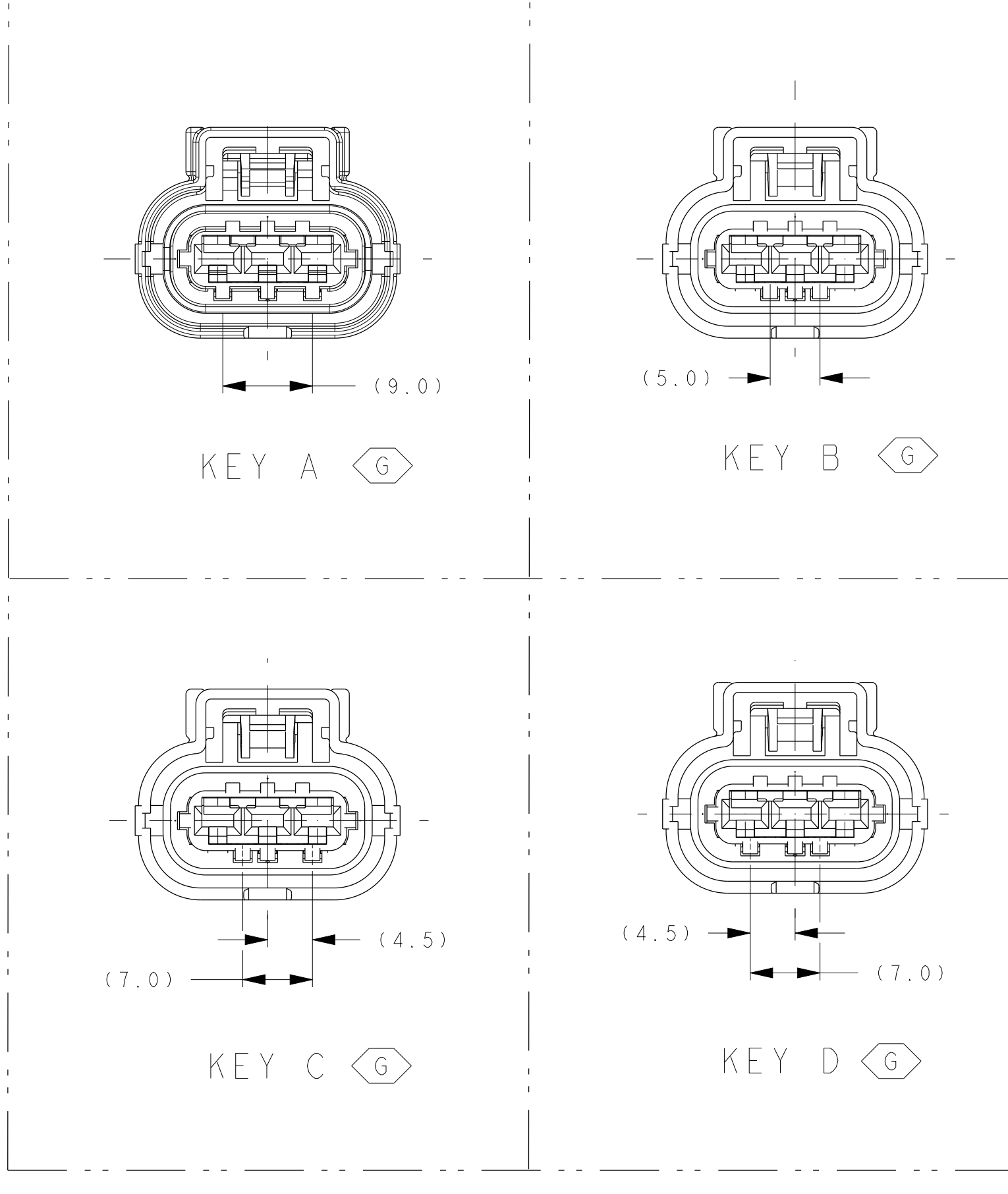

SECTION A-A SHOWN WITH OPTIONAL CPA

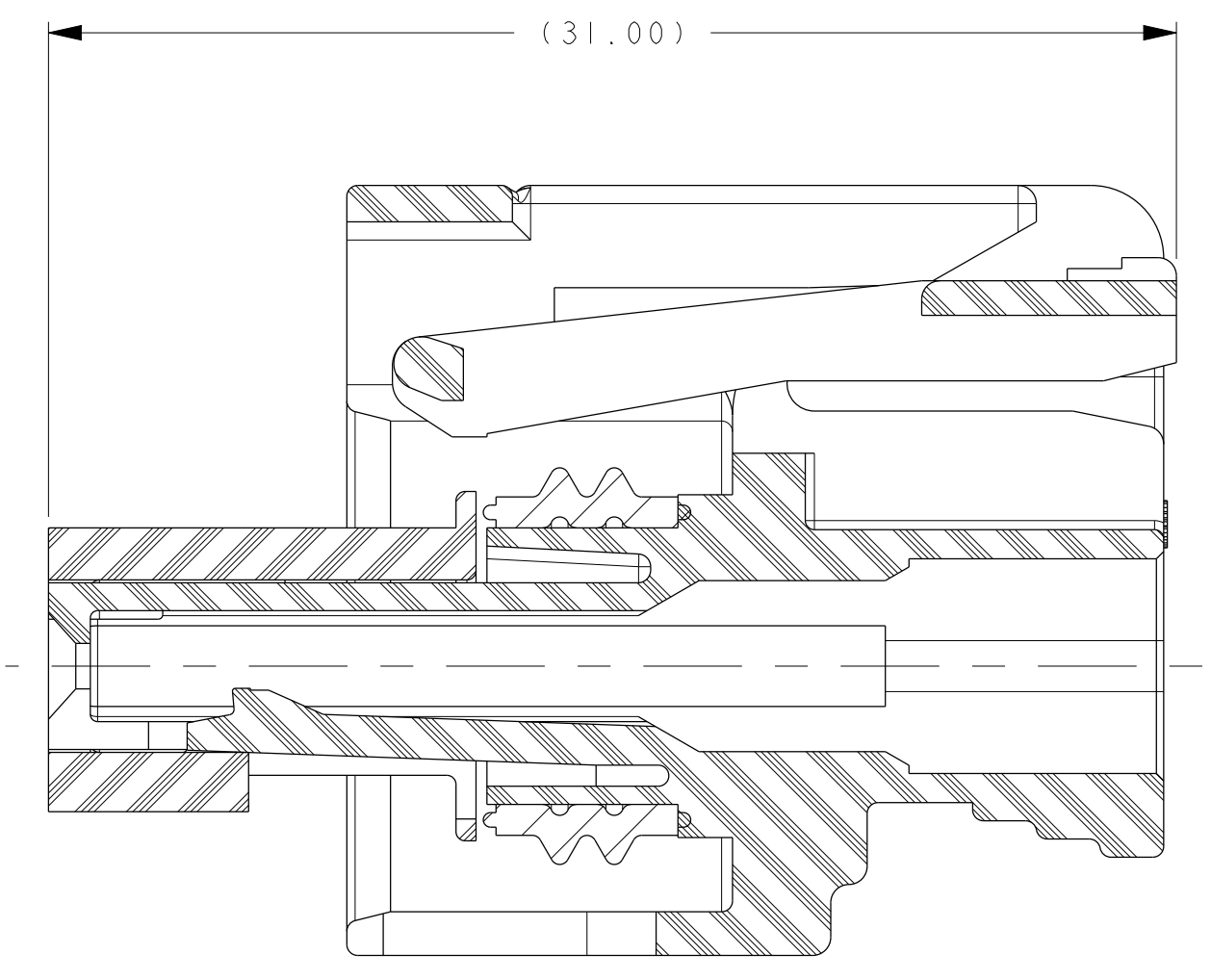

SECTION A-A TPA SHOWN IN FINAL LOCK POSITION

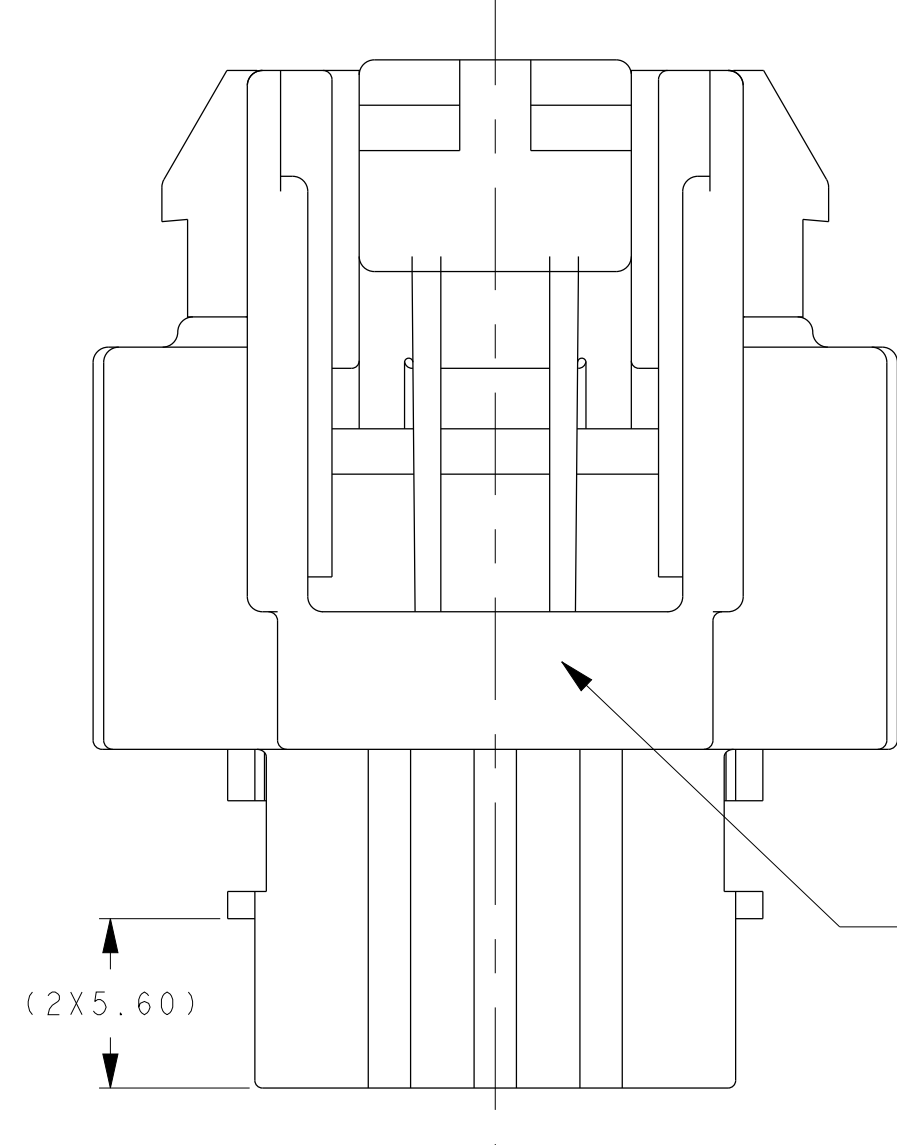

OPTIONAL CONSTRUCTION TPA WITH SHORT RIB

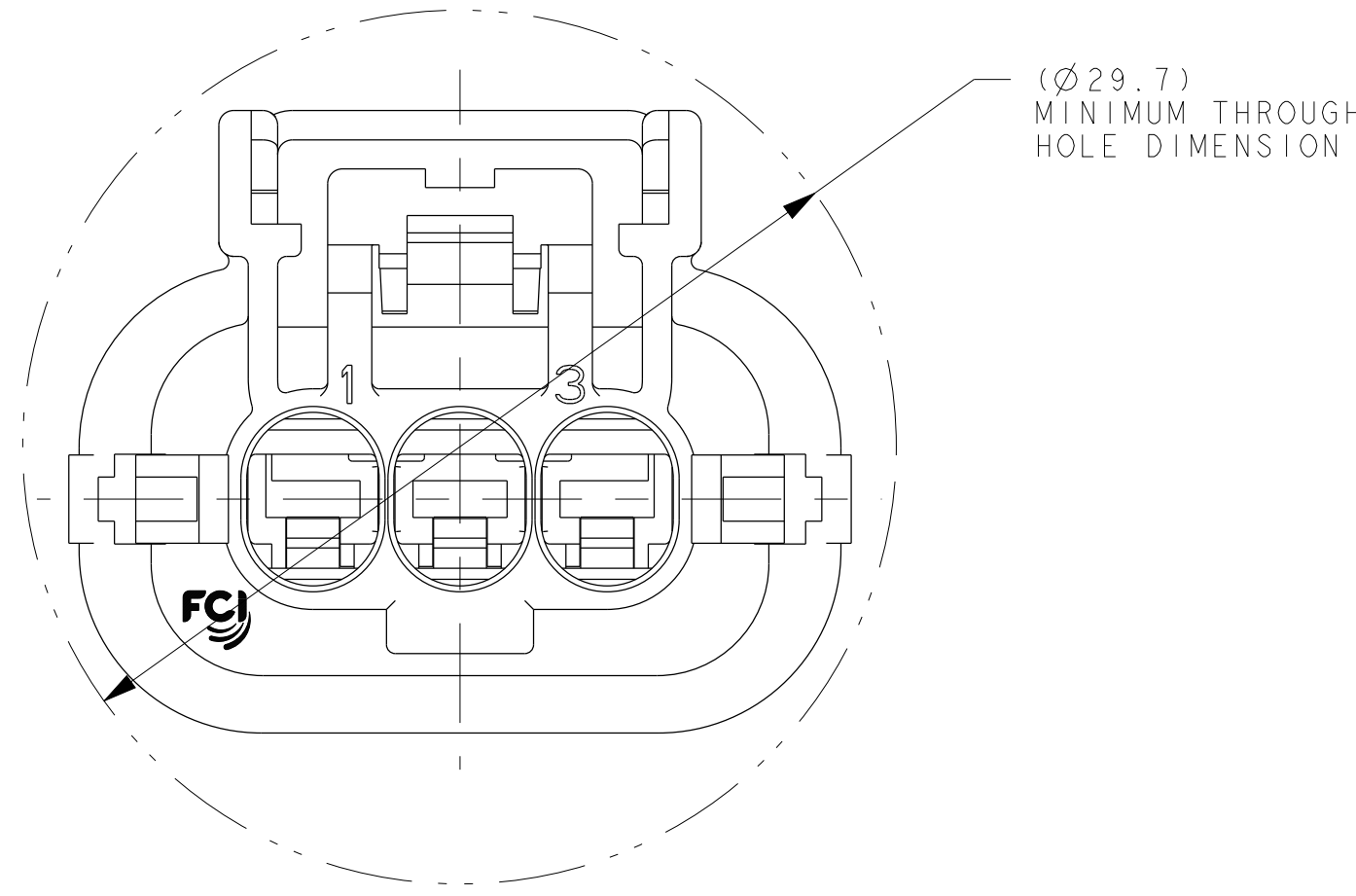

(Ø29.7) MINIMUM THROUGH HOLE DIMENSION

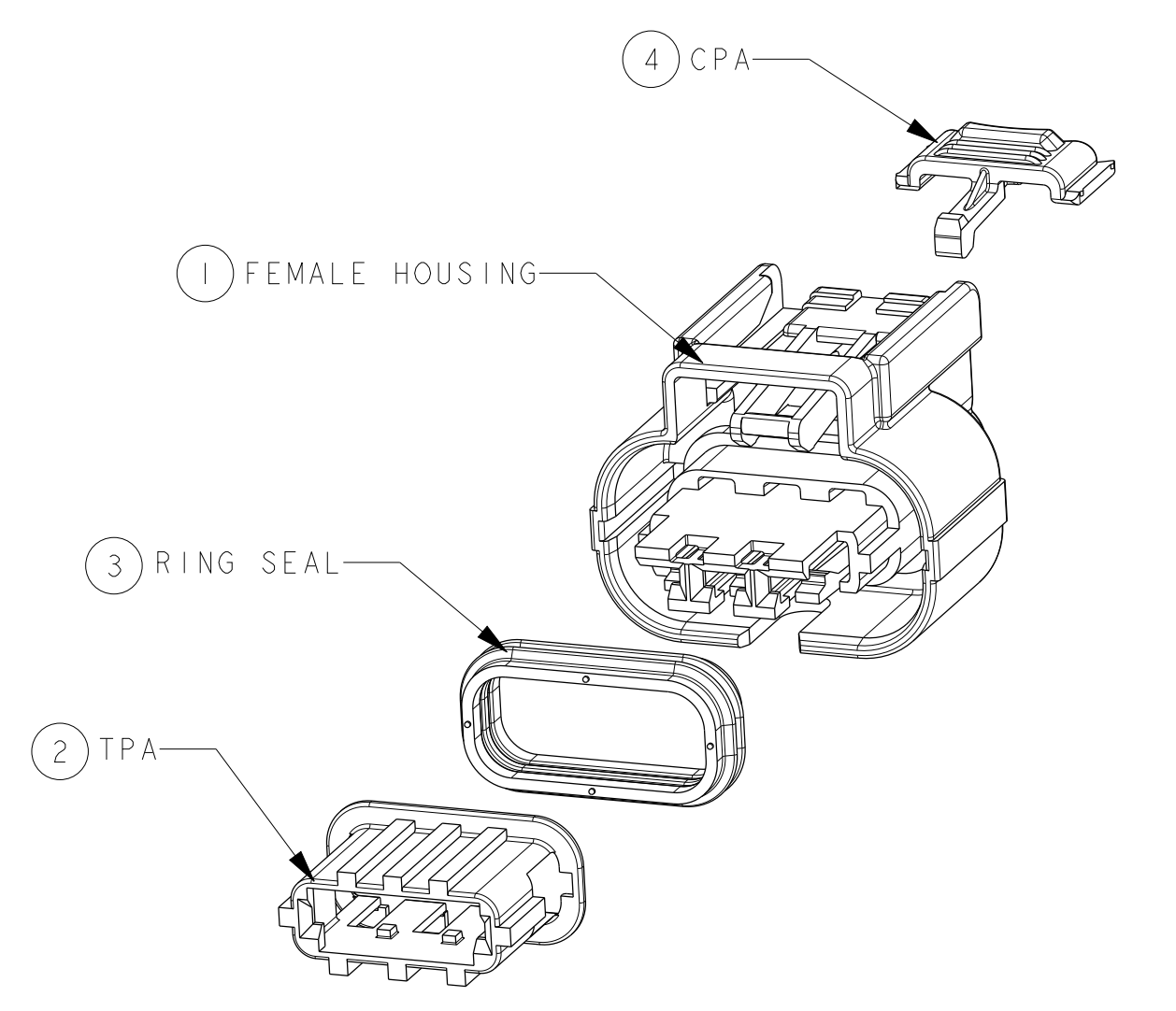

SCALE 2:1

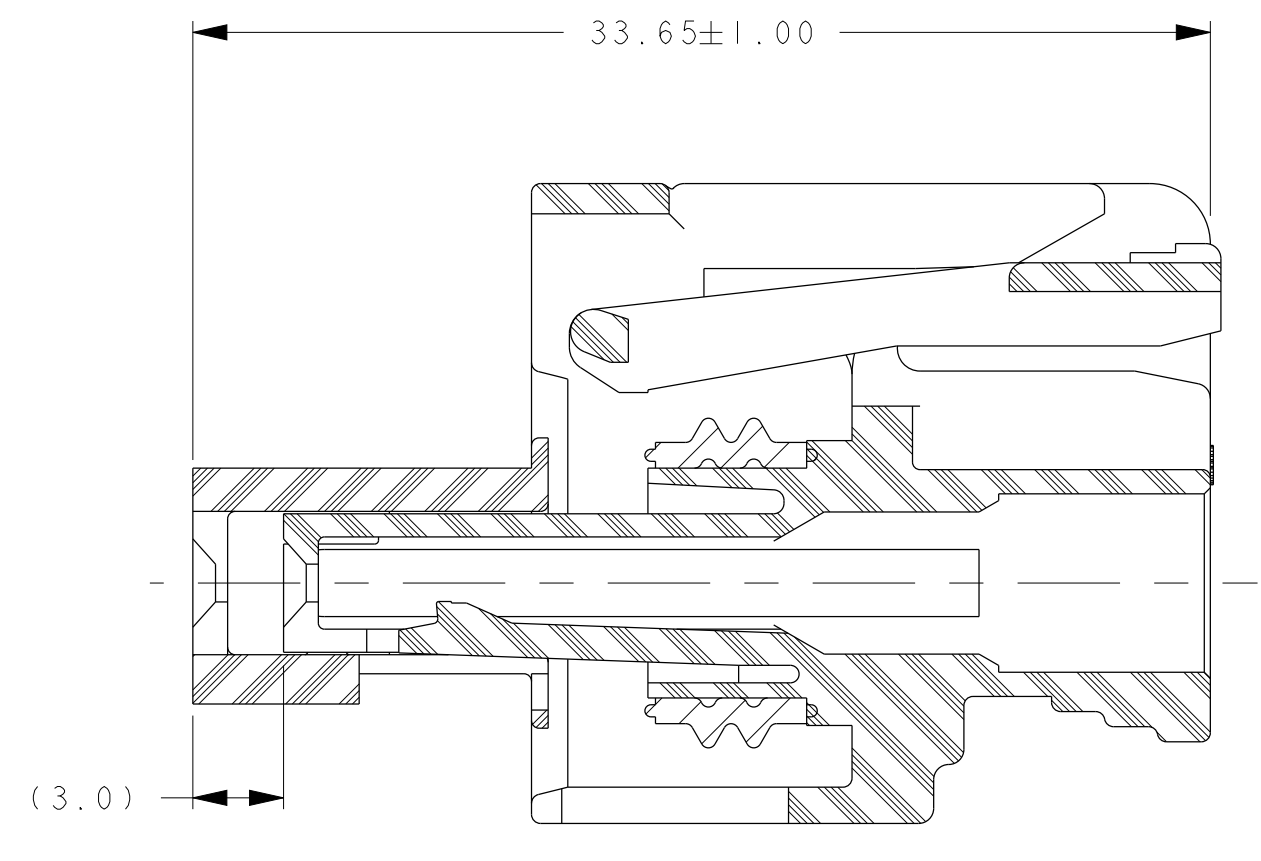

SECTION A-A TPA SHOWN IN PRE-LOCK POSITION

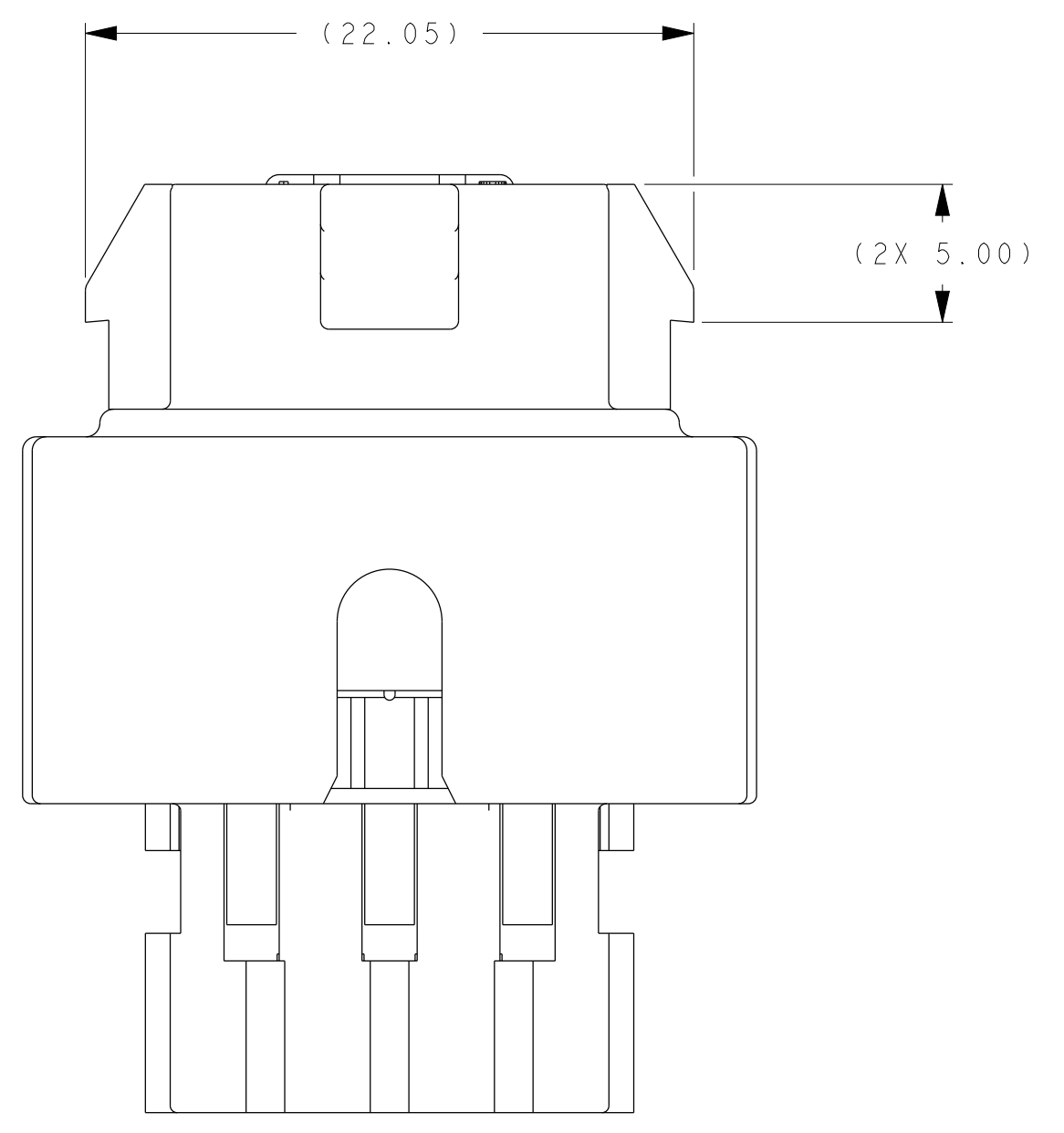
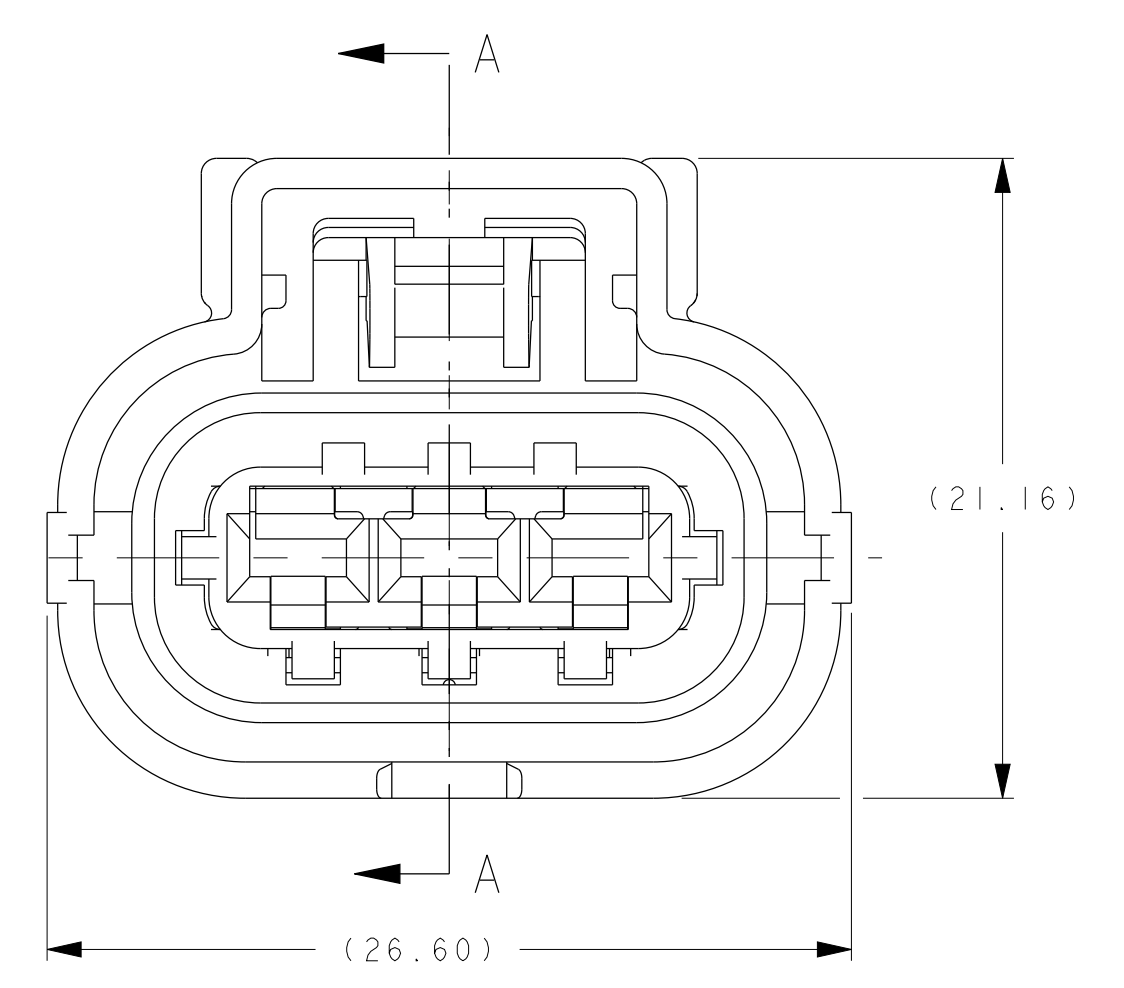

NOTES:

- VALIDATED TO SAE/USCAR-2 REV 5
- VALIDATED TO THE FOLLOWING TEMP, VIBRATION, AND SEALING CLASSES:
 - SAE/USCAR-2 V3 T3 (125°C) WITH GOLD TERMINALS
 - SAE/USCAR-2 SEALING S3 T3 (125°C)(ISO16750 9K EQUIVALENT)
- CONNECTOR MAY BE USED WITH THE FOLLOWING TERMINALS:
 - DELPHI APEX 2.8 TERMINALS LISTED IN THE APPLICABLE COMPONENTS CHART ON THIS DRAWING WITH WIRE SIZES DEFINED IN NOTE 4.
 - SEE DELPHI DRAWING C15004-CUST FOR SPECIFIC TERMINAL DETAILS AND CRIMPING REQUIREMENTS
 - PLATING OF TERMINALS AND MATING DEVICE BLADES MUST BE COMPATIBLE SEE NOTE 5
 - EXCESSIVELY THICK TIN PLATING ON DEVICE BLADES IS NOT RECOMMENDED
- CONNECTOR SYSTEM VALIDATED TO USCAR-2 REQUIREMENTS WITH THE FOLLOWING RANGE OF WIRE SIZES AND TYPES IN CONJUNCTION WITH APPROPRIATE COMPONENTS FOUND IN THE "APPLICABLE COMPONENTS" CHART:
 - AWG - WIRE SIZES: 20AWG - 14AWG
 - INSULATION DIAMETER: 1.70mm MIN - 2.77mm MAX
 - WIRE TYPE: MLI-123-A, MS-8288 OR EQUIVALENT (STRUCTURE AND PROPERTIES ACCORDING TO SAE J1128)
 - METRIC - WIRE SIZE: 0.50mm² - 2.50mm²
 - INSULATION DIAMETER: 1.40mm MIN - 3.00mm MAX
 - WIRE TYPE: FLR2X-A OR EQUIVALENT (STRUCTURE AND PROPERTIES ACCORDING TO ISO 6722)

CONTACT DELPHI ENGINEERING REGARDING USE OF OTHER WIRE SIZES AND/OR TYPES WIRE AND INSULATION TYPE MUST BE APPROPRIATE FOR TEMPERATURE CLASS & APPLICATION ENVIRONMENT
- CONNECTOR IS MATE COMPATIBLE WITH DEVICES CONFORMING WITH THE FOLLOWING INTERFACE SPECIFICATIONS:
 - BOSCH DWG 1928500000 VARIANT A
 - GM DWG 13115604

FOR CONSTRUCTION OF NEW DEVICES, SEE SHEET 2 FOR INTERFACE DETAILS.

NOTE: EXCESSIVELY THICK TIN PLATING ON DEVICE BLADES IS NOT RECOMMENDED, SEE EWCAP-001 (280-T001) BLADE SPECIFICATION FOR PREFERRED PLATING

DEVICE SUPPLIERS RESPONSIBLE FOR VALIDATING PERFORMANCE OF DEVICE TO SAE/USCAR-2 REV 5
- ANNUAL QUALITY REQUIREMENTS:
 - IT IS PERMISSIBLE TO PERFORM CONTINUOUS PERFORMANCE PER DELPHI SPECIFICATION #80A-001 INSTEAD OF ANNUAL LAYOUT AND ANNUAL PV REQUIREMENTS OF ISO TS16949 AND SAE/USCAR-2 REV 5. FOR TERMINAL TO CONNECTOR AND TPA TO CONNECTOR ONLY.
- SOURCE ID, MOLD & CAVITY ID SIGNIFIES TOOL OWNERSHIP, FOR REFERENCE
- (K) INDICATES IN-PROCESS INSPECTION FOR MANUFACTURING DIMENSIONS OR SPECIFICATIONS.

ECO 423850, UPDATE VIEWS FOR DESIGN IMPROVEMENT TO CPA F152210, DELPHI P/N'S ADDED FOR W/L P/N'S, REVISED NOTE 5, REMOVED PART NUMBERS 54001432, 54001448, 54001840 AND 54001879, ADD SHEET 2 WITH INTERFACE DETAILS

REVISED NOTE 4 WITH 0.5mm WIRE INFO

REVISED NOTE 5, CORRECTED WIRE INSULATION DIA RANGE FOR F516000 2.18mm-2.80mm WAS 2.18mm-2.77mm

REVISED PART NUMBER: F15210 WAS F181210

NEW RELEASE - RELEASED AT REV 0

REV	DATE	BY	CHKD	DESCRIPTION
1				INITIAL RELEASE
2				REVISED NOTE 4 WITH 0.5mm WIRE INFO
3				REVISED NOTE 5, CORRECTED WIRE INSULATION DIA RANGE FOR F516000 2.18mm-2.80mm WAS 2.18mm-2.77mm
4				REVISED PART NUMBER: F15210 WAS F181210
5				NEW RELEASE - RELEASED AT REV 0

DELPHI
PCC0606106
SERIAL RELEASED
SCALE 4:0

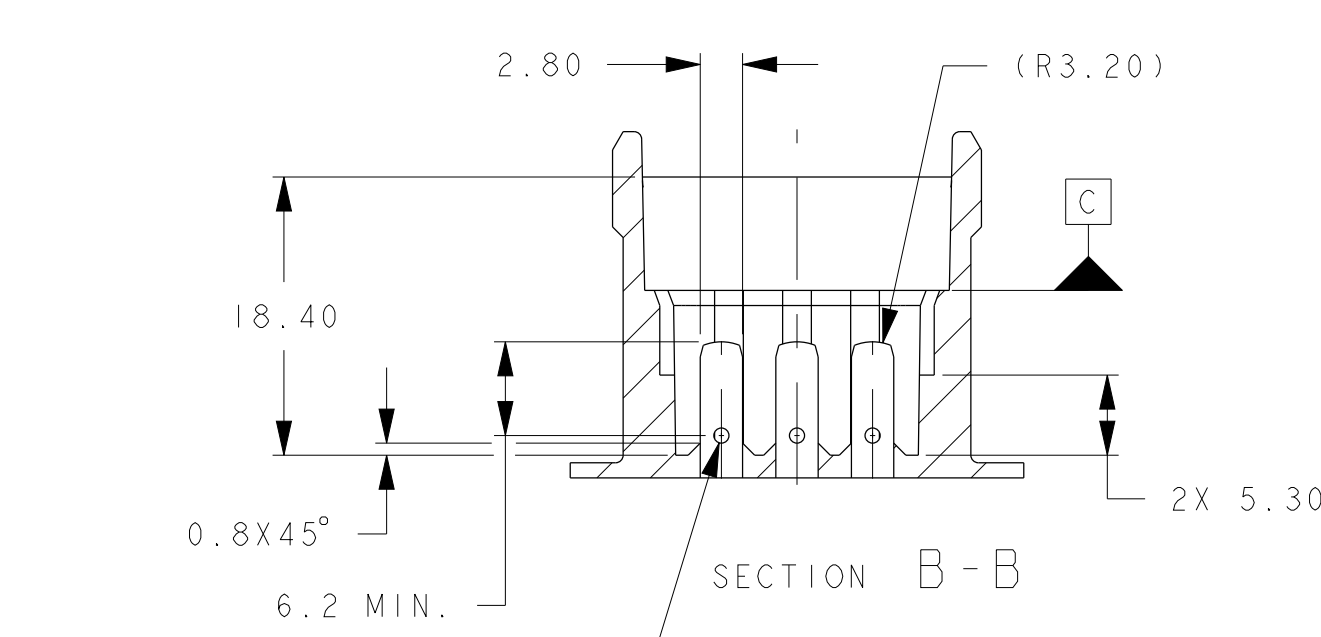
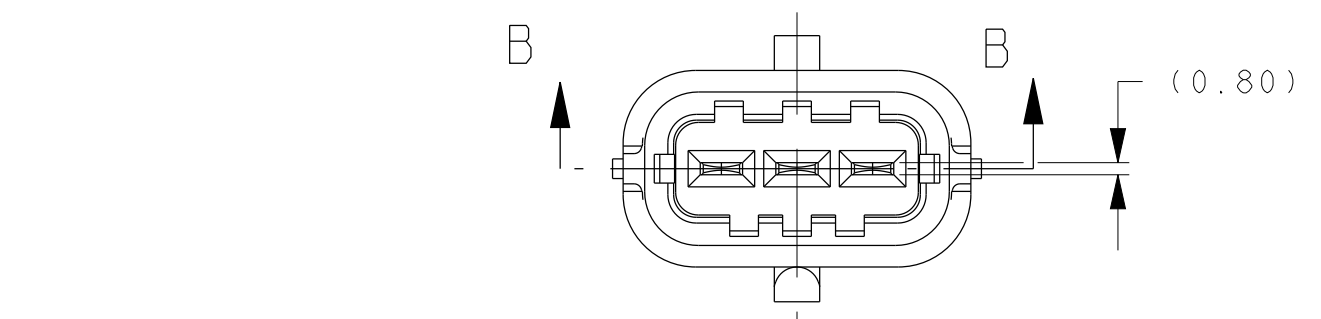

HOLE $\phi 0.5 \pm 0.1$ ADMISSIBLE IN CASE OF USE. CHAMFER $0.8 \times 45^\circ$ IS NOT REQUIRED

PROVIDED FOR INFORMATION PURPOSE ONLY

DEPICTED FEATURES NOT TO BE INCLUDED ON NEWLY TOOLED HEADERS. THIS MAY BE PRESENT ON CURRENT OLDER HEADERS.

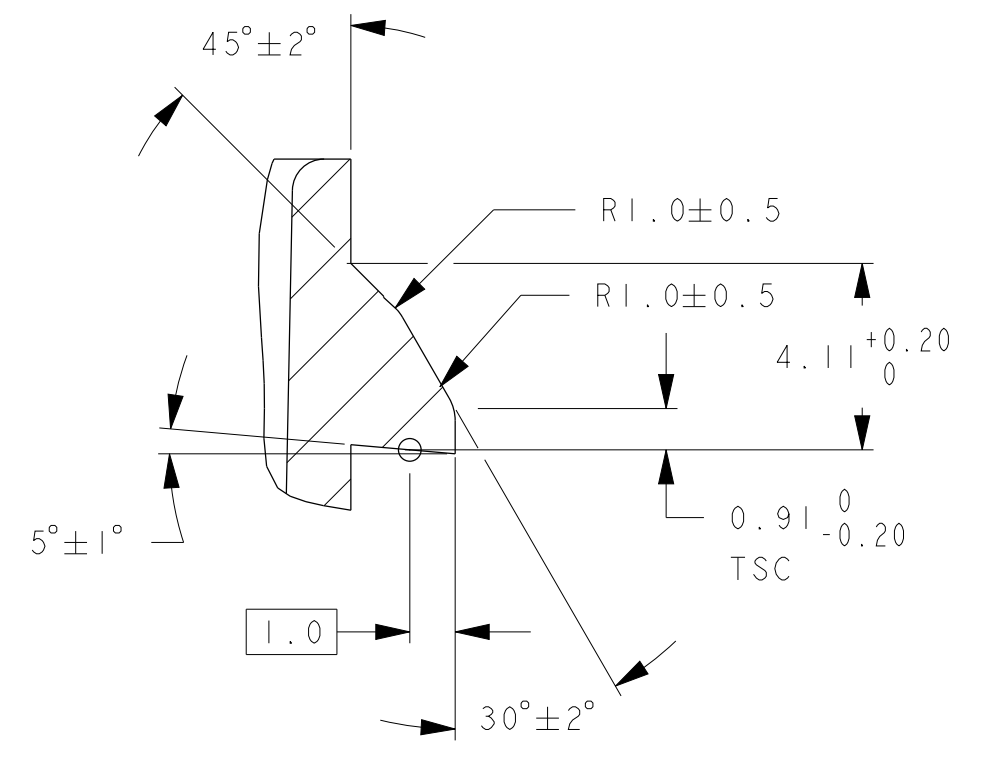
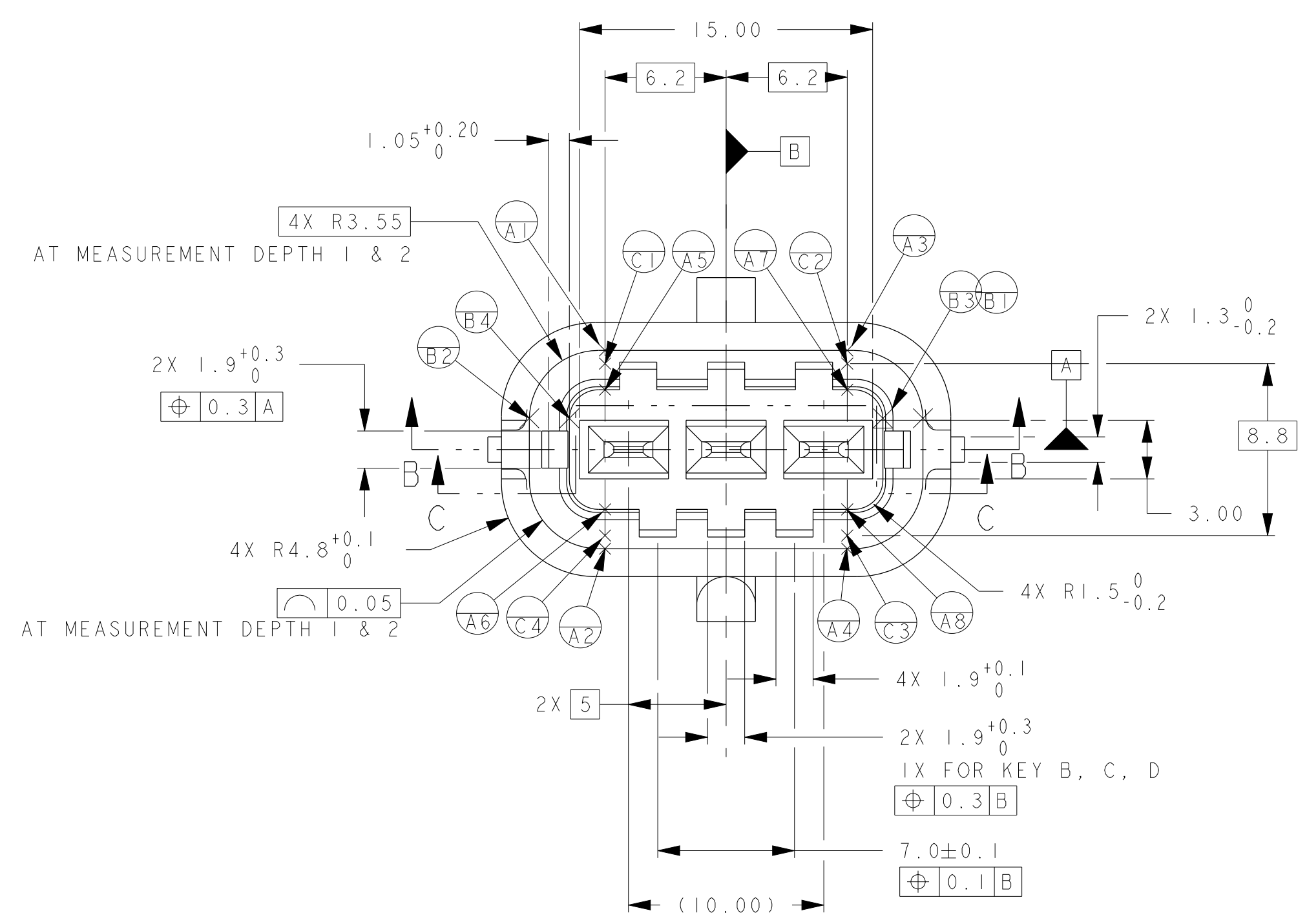

DETAIL Y SCALE 6:1

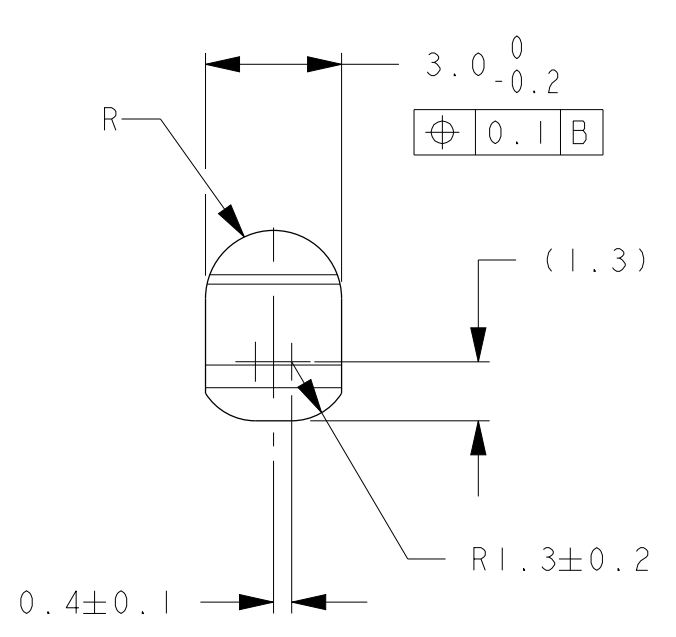

DETAIL X SCALE 6:1

LATCH CONSTRUCTION

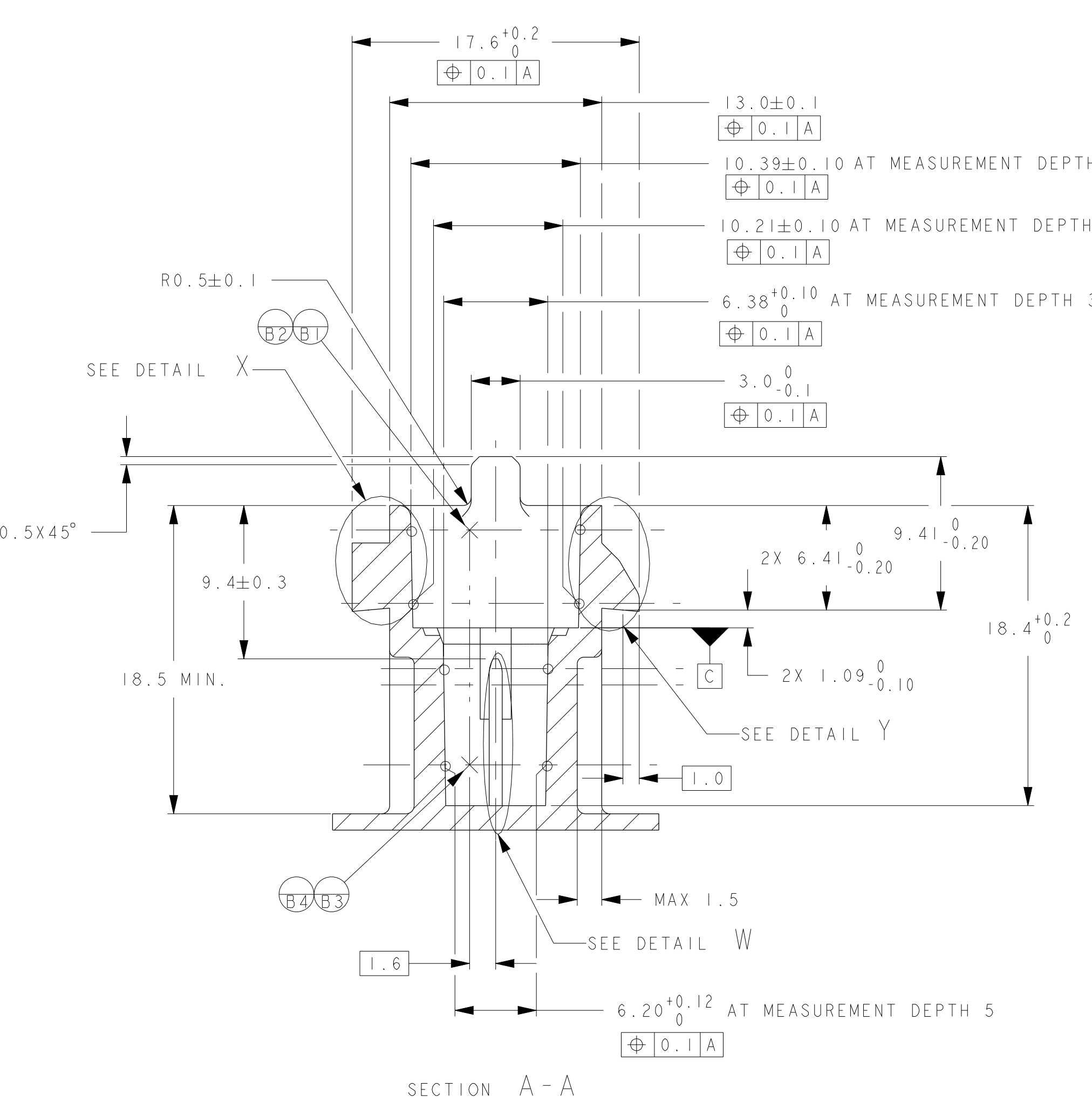

SECTION A-A

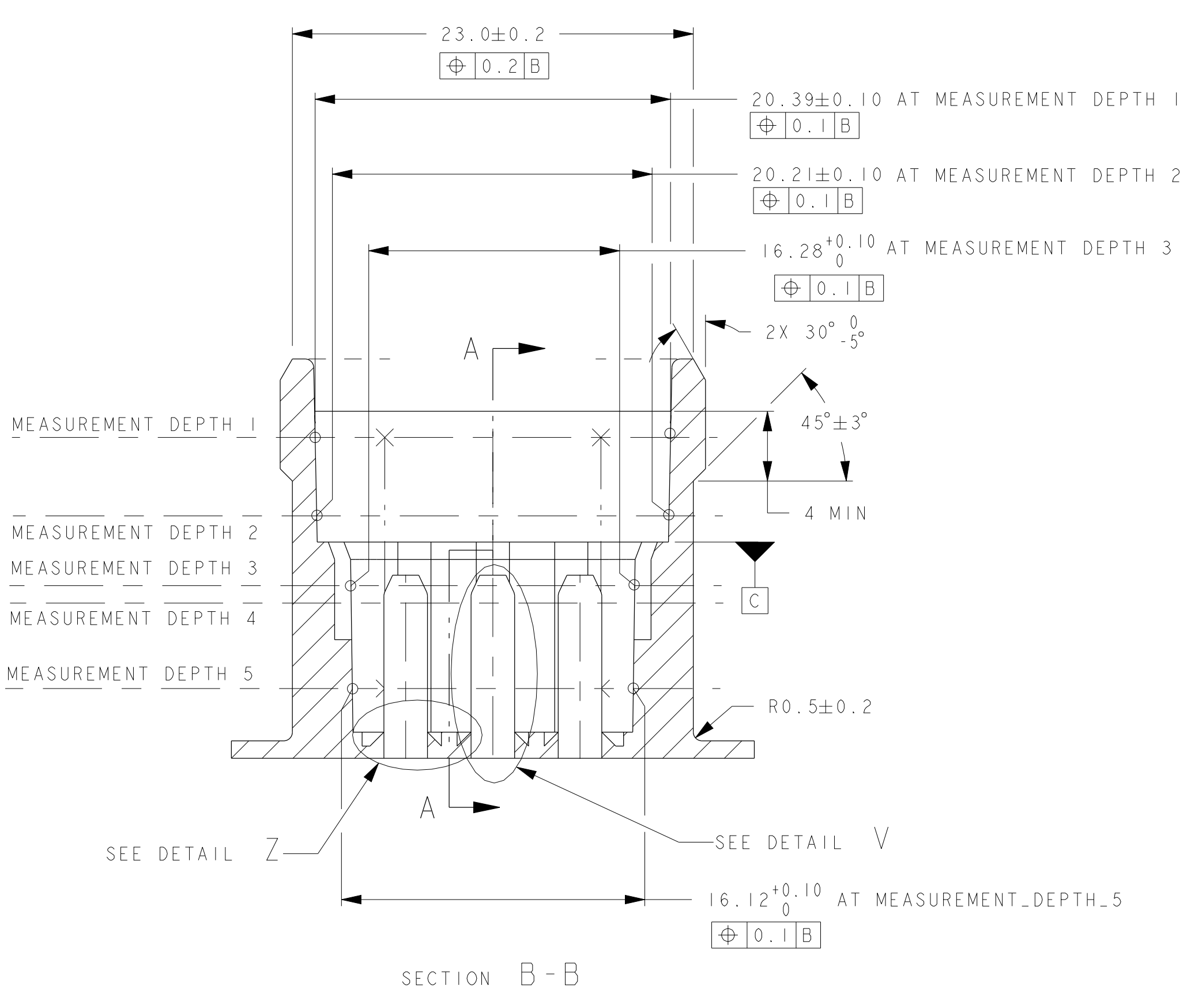

SECTION B-B

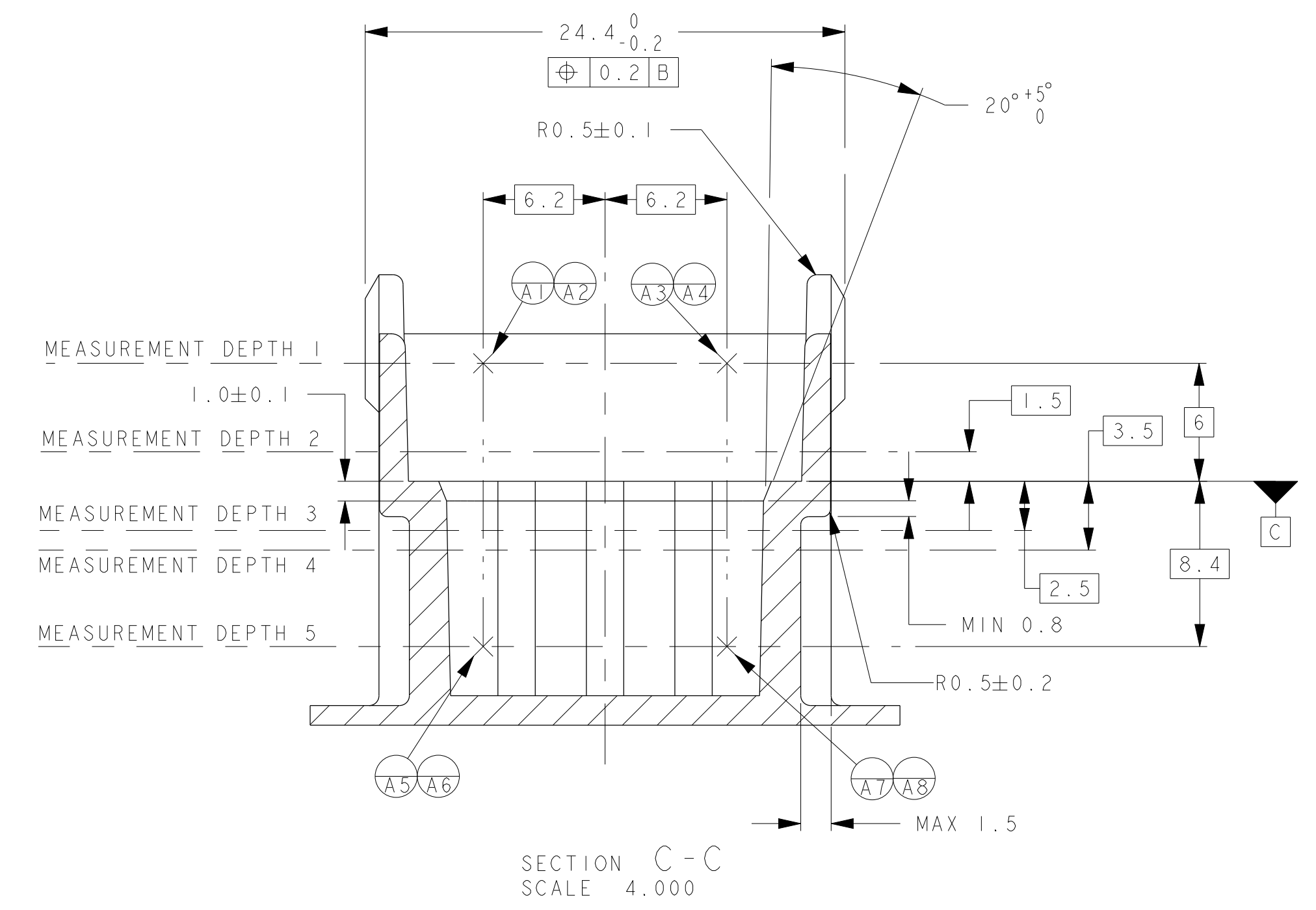

SECTION C-C SCALE 4.000

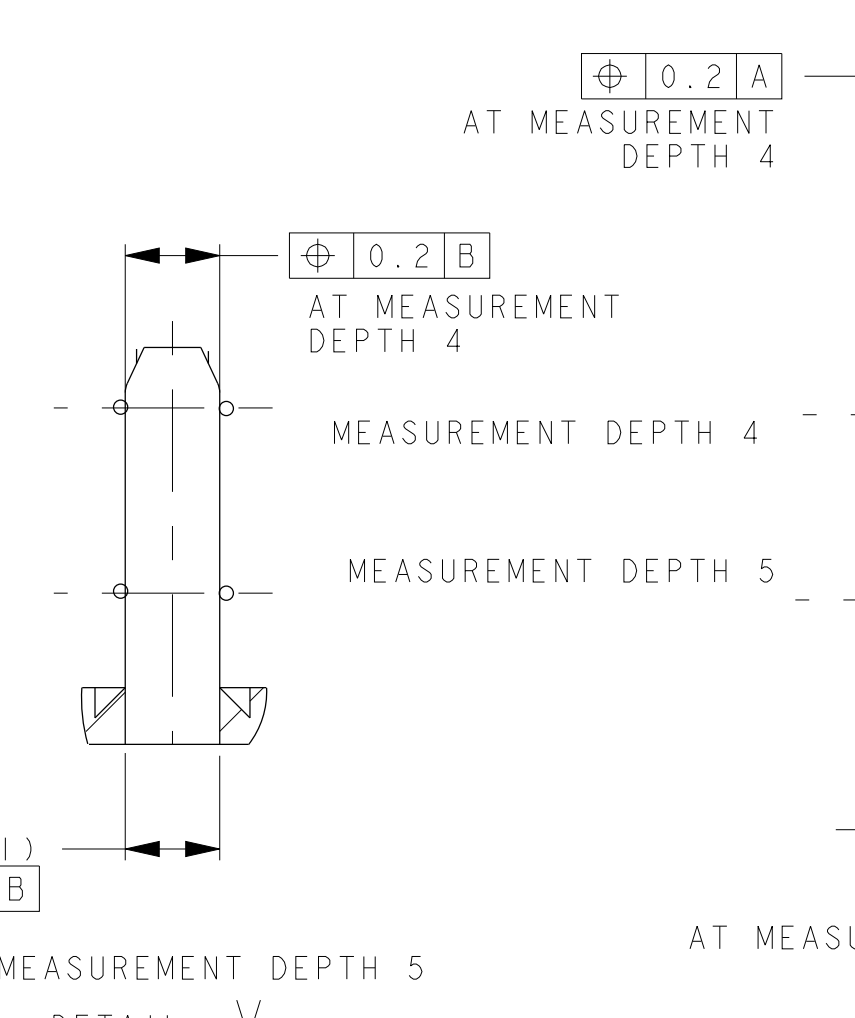
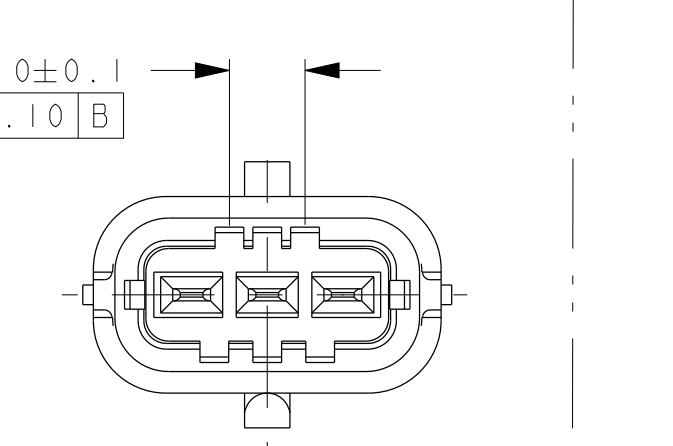
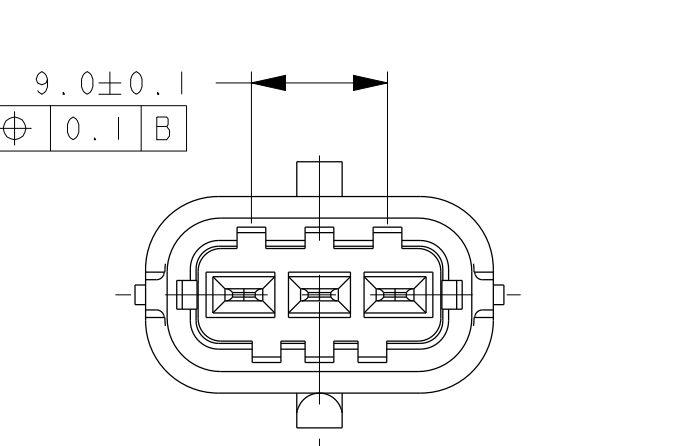

DETAIL V SCALE 5.000

DETAIL W SCALE 5.000

HEADER PINS APPLIES 3X

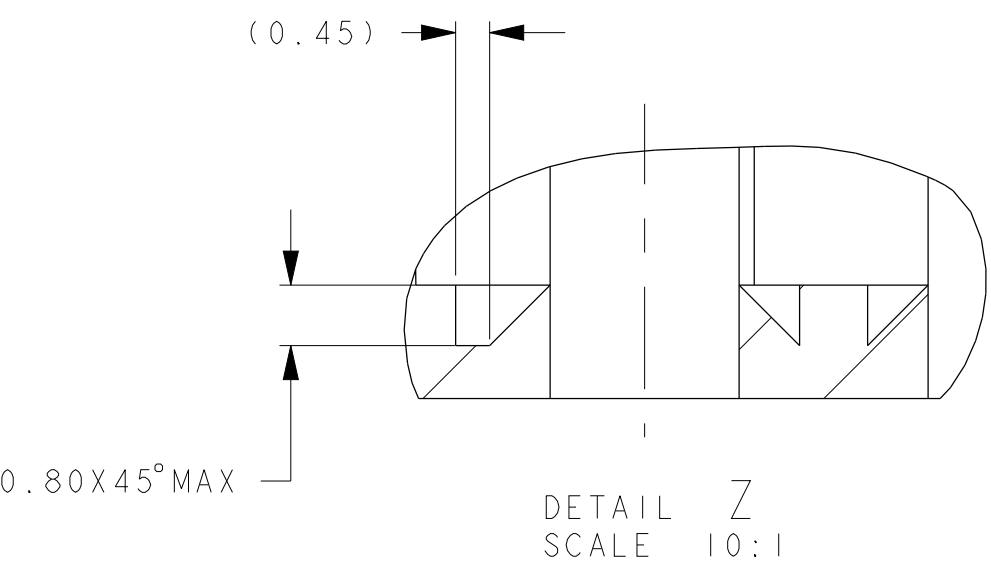
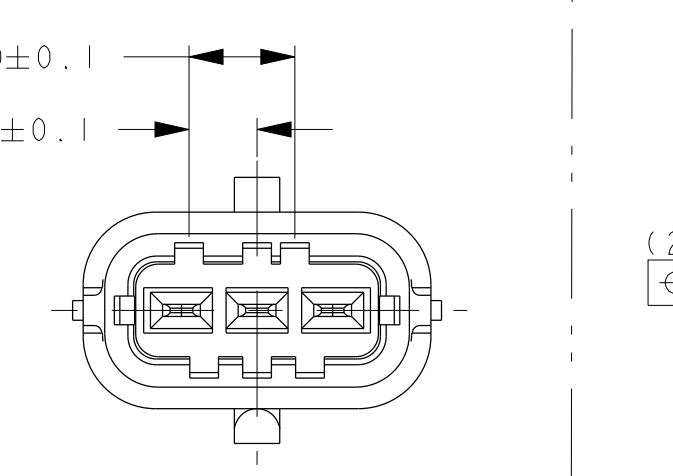
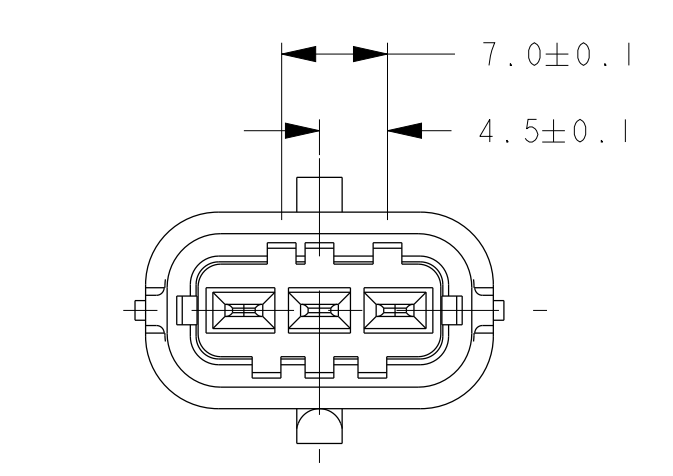

DETAIL Z SCALE 10:1

INTERFACE NOTES (REF):
1. FOR HEADER BLADE INFORMATION SEE EWCAP DRAWING EWCAP-001.

SEE SHEET 1 FOR REV HISTORY		CHANGE DESCRIPTION	
REV. NO.	ZONE	DATE	DESCRIPTION
1			ISSUED FOR MANUFACTURE

PROJECT SPEC	PACKAGING SPEC	APPLICATION SPEC	COPYRIGHT DELPHI CORPORATION AND/OR ITS AFFILIATES. ALL RIGHTS RESERVED. REVISED THIS DRAWING IS THE PROPERTY OF DELPHI CORPORATION AND CONTAINS DELPHI CONFIDENTIAL INFORMATION. THE REPRODUCING, DISTRIBUTION AND UTILIZATION OF THIS DOCUMENT FOR ANY OTHER THAN THE ORIGINAL USER IS STRICTLY PROHIBITED.
DESIGNER	DATE	NAME	SCALE
PROJECT	DATE	NAME	SCALE
PROJECT	DATE	NAME	SCALE
PROJECT	DATE	NAME	SCALE
PROJECT	DATE	NAME	SCALE

REV. NO.	DATE	BY	CHKD BY
1			

PROJECT	DATE	NAME	SCALE
PROJECT	DATE	NAME	SCALE
PROJECT	DATE	NAME	SCALE
PROJECT	DATE	NAME	SCALE
PROJECT	DATE	NAME	SCALE



Компания «ЭлектроПласт» предлагает заключение долгосрочных отношений при поставках импортных электронных компонентов на взаимовыгодных условиях!

Наши преимущества:

- Оперативные поставки широкого спектра электронных компонентов отечественного и импортного производства напрямую от производителей и с крупнейших мировых складов;
- Поставка более 17-ти миллионов наименований электронных компонентов;
- Поставка сложных, дефицитных, либо снятых с производства позиций;
- Оперативные сроки поставки под заказ (от 5 рабочих дней);
- Экспресс доставка в любую точку России;
- Техническая поддержка проекта, помощь в подборе аналогов, поставка прототипов;
- Система менеджмента качества сертифицирована по Международному стандарту ISO 9001;
- Лицензия ФСБ на осуществление работ с использованием сведений, составляющих государственную тайну;
- Поставка специализированных компонентов (Xilinx, Altera, Analog Devices, Intersil, Interpoint, Microsemi, Aeroflex, Peregrine, Syfer, Eurofarad, Texas Instrument, Miteq, Cobham, E2V, MA-COM, Hittite, Mini-Circuits, General Dynamics и др.);

Помимо этого, одним из направлений компании «ЭлектроПласт» является направление «Источники питания». Мы предлагаем Вам помощь Конструкторского отдела:

- Подбор оптимального решения, техническое обоснование при выборе компонента;
- Подбор аналогов;
- Консультации по применению компонента;
- Поставка образцов и прототипов;
- Техническая поддержка проекта;
- Защита от снятия компонента с производства.



Как с нами связаться

Телефон: 8 (812) 309 58 32 (многоканальный)

Факс: 8 (812) 320-02-42

Электронная почта: org@eplast1.ru

Адрес: 198099, г. Санкт-Петербург, ул. Калинина, дом 2, корпус 4, литера А.