

Description

The AP7315Q is a low dropout regulator with high output voltage accuracy, low $R_{DS(ON)}$, high PSRR, low output noise and low quiescent current. This regulator is based on a CMOS process.

The AP7315Q is available with fixed output voltage variants with an enable input to turn it on and off. It is available with output discharge (AP7315DQ) and without (AP7315Q) output discharge function.

With its low power consumption and, line and load transient responses the AP7315Q is well suited for noise sensitive automotive applications.

The AP7315Q is qualified to AEC-Q100 Grade 1 in SOT25 and is Automotive Compliant supporting PPAPs.

Features

- Wide V_{IN} Range: 1.7V to 5.25V
- -40°C to $+125^{\circ}\text{C}$ Temperature Range
- Guarantee Output Current, 150mA
- V_{OUT} Accuracy $\pm 1\%$
- Ripple Rejection 75dB at 1kHz
- Low Output Noise, $60\mu\text{V}_{\text{rms}}$ from 10Hz to 100kHz
- Quiescent Current as Low as $35\mu\text{A}$
- V_{OUT} Fixed 1.1V to 3.3V
- **Totally Lead-Free & Fully RoHS Compliant (Notes 1 & 2)**
- **Halogen and Antimony Free, Green Device (Note 3)**
- **Qualified to AEC-Q100 Standards for High Reliability**
- **AEC-Q100 Grade 1**
- **PPAP Capable (Note 4)**

Pin Assignments

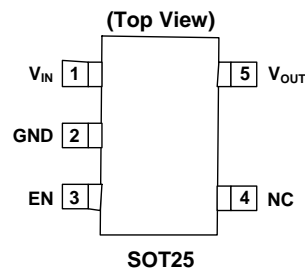

Applications

- Infotainment Power Supplies
- Automotive RF Supply
- Cameras
- Automotive POL in ADAS
- Automotive Wireless Communication

- Notes:
1. No purposely added lead. Fully EU Directive 2002/95/EC (RoHS), 2011/65/EU (RoHS 2) & 2015/863/EU (RoHS 3) compliant.
 2. See <https://www.diodes.com/quality/lead-free/> for more information about Diodes Incorporated's definitions of Halogen- and Antimony-free, "Green" and Lead-free.
 3. Halogen- and Antimony-free "Green" products are defined as those which contain <900ppm bromine, <900ppm chlorine (<1500ppm total Br + Cl) and <1000ppm antimony compounds.
 4. Automotive Compliant products are AEC-Q100 qualified and are PPAP capable. Refer to http://www.diodes.com/quality/product_compliance_definitions/.

Typical Applications Circuit

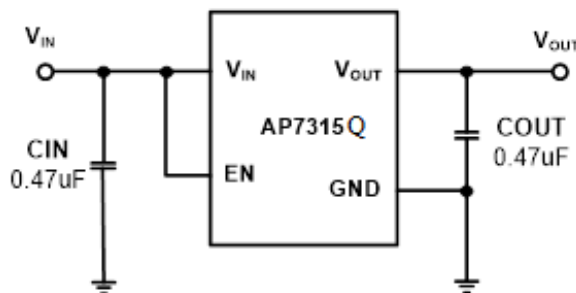

Pin Descriptions

Pin Number	Pin Name	Function
1	V _{IN}	Power Input Pin
2	GND	Ground
3	EN	Enable Pin This pin should be driven either high or low and must not be floating. Driving this pin high enables the regulator, and pulling it low puts the regulator into shutdown mode.
4	NC	No Connection
5	V _{OUT}	Power Output Pin

Functional Block Diagram

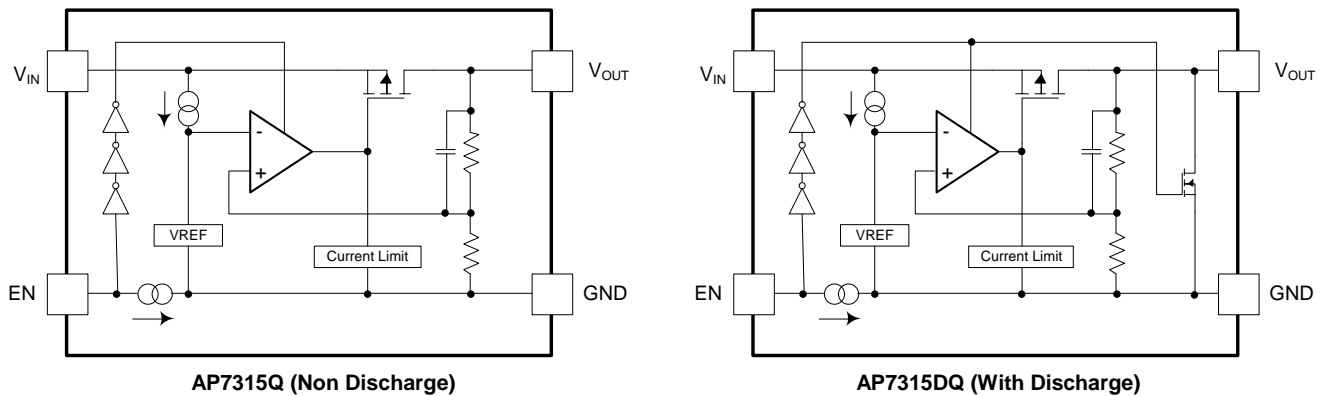

Absolute Maximum Ratings (Note 5) (@T_A = +25°C, unless otherwise specified.)

Symbol	Parameter	Ratings	Unit
ESD HBM	Human Body Mode ESD Protection	>2	KV
ESD CDM	Charge Device Model	±500	V
V _{IN}	Input Voltage	6.0	V
V _{EN}	Input Voltage EN	6.0	V
V _{OUT}	Output Voltage	-0.3 to V _{IN} +0.3	V
I _{OUT}	Output Current	300	mA
P _D	Power Dissipation	400	mW
T _J	Operating Junction Temperature	-40 to +150	°C
T _{STG}	Storage Temperature	-55 to +150	°C

Note: 5. a) Stresses beyond those listed under *Absolute Maximum Ratings* can cause permanent damage to the device. These are stress ratings only and functional operation of the device at these conditions is not implied. Exposure to absolute-maximum-rated conditions for extended periods can affect device reliability.
 b) Ratings apply to ambient temperature at +25°C. The JEDEC High-K board design used to derive this data is a 2in. x 2in. multilayer board with 1oz. internal power and ground planes and 2oz. copper traces on the top and bottom of the board.

Recommended Operating Conditions (@T_A = +25°C, unless otherwise specified.)

Symbol	Parameter	Min	Max	Unit
V _{IN}	Input Voltage Range	1.7	5.25	V
I _{OUT}	Output Current	0	150	mA
T _J	Operating Junction Temperature	-40	+125	°C
T _A	Operating Ambient Temperature (Note 6)	-40	+125	°C

Note: 6. Ambient temperature range is subject to the junction temperature not exceeding 125°C.

Electrical Characteristics (V_{EN} = V_{IN} = V_{OUT} + 1.0V, C_{IN} = C_{OUT} = 0.47µF, I_{OUT} = 1.0mA @T_A = +25°C, unless otherwise specified.)

Parameter	Conditions	Min	Typ	Max	Units	
Output Voltage Accuracy (Note 7)	V _{OUT} ≥ 2.0V, V _{IN} = V _{OUT} +1V, T _A = +25°C	V _{OUT} × 0.99	V _{OUT}	V _{OUT} × 1.01	V	
	V _{OUT} < 2.0V, V _{IN} = V _{OUT} +1V, T _A = +25°C	V _{OUT} -20mV	V _{OUT}	V _{OUT} + 20mV	V	
Line Regulation (dV _{OUT} /dV _{IN} /V _{OUT})	V _{IN} = (V _{OUT} - Nom + 1.0V) to 5.25V, I _{OUT} = 1.0mA	—	0.02	0.1	%/V	
Load Regulation (dV _{OUT} /V _{OUT} /dI _{OUT})	V _{IN} = V _{OUT} - Nom + 1.0V, I _{OUT} = 1mA to 150mA	—	0.5	1.0	%/A	
Quiescent Current (Note 8)	I _{OUT} = 0mA	20	35	60	µA	
	I _{OUT} = 150mA	30	60	100		
I _{STANDBY}	V _{EN} = 0V (Disabled)	—	0.01	1.0	µA	
Output Current	—	150	—	—	mA	
Fold-back Short Current (Note 9)	V _{OUT} Short to Ground	—	55	—	mA	
PSRR (Note 10)	V _{IN} = (V _{OUT} +1V)V _{DC} + 0.2V _{p-pAC} , V _{OUT} ≥ 1.8V, I _{OUT} = 30mA f = 1kHz	—	75	—	dB	
Output Noise Voltage (Notes 10, 11)	BW = 10Hz to 100kHz, I _{OUT} = 30mA	—	60	—	µVrms	
Dropout Voltage (Note 12)	I _{OUT} = 150mA	1.1V ≤ V _{OUT} < 1.5V	—	0.50	0.64	V
		1.5V ≤ V _{OUT} < 1.7V	—	0.38	0.49	
		1.7V ≤ V _{OUT} < 2.0V	—	0.34	0.44	
		2.0V ≤ V _{OUT} < 2.5V	—	0.28	0.38	
		2.5V ≤ V _{OUT} < 2.8V	—	0.22	0.32	
		2.8V ≤ V _{OUT} ≤ 3.3V	—	0.21	0.29	
Output Voltage Temperature Coefficient	I _{OUT} = 30mA, T _A = -40°C to +85°C	—	±30	—	ppm/°C	
EN Input Low Voltage	—	0	—	0.5	V	
EN Input High Voltage	—	1.3	—	5.25	V	
EN Input Leakage	V _{EN} = 0, V _{IN} = 5.0V or V _{EN} = 5.0V, V _{IN} = 0V	-1.0	—	+1.0	µA	
On Resistance of N-channel for Auto-Discharge (Note 13)	V _{IN} = 4.0V V _{EN} = 0V (Disabled)	—	30	—	Ω	
Thermal Resistance (Note 14) Junction to Ambient (Θ _{JA})	—	—	179	—	°C/W	
Junction to Case (Θ _{JC})	—	—	52	—		

- Notes:
- Potential multiple grades based on following output voltage accuracy.
 - Quiescent current is defined here is the difference in current between the input and the output.
 - Short circuit current is measured with V_{OUT} pulled to GND.
 - This specification is guaranteed by design.
 - To make sure lowest environment noise minimizes the influence on noise measurement.
 - Dropout voltage is the voltage difference between the input and the output at which the output voltage drops 2% below its nominal value
 - AP7315Q has 2 options for output, built-in discharge and non-discharge.
 - Thermal impedances measured on PCB of type and size with which top layer and bottom layer metal coverage

Typical Characteristics

Output Voltage vs. Output Current
AP7315Q-18

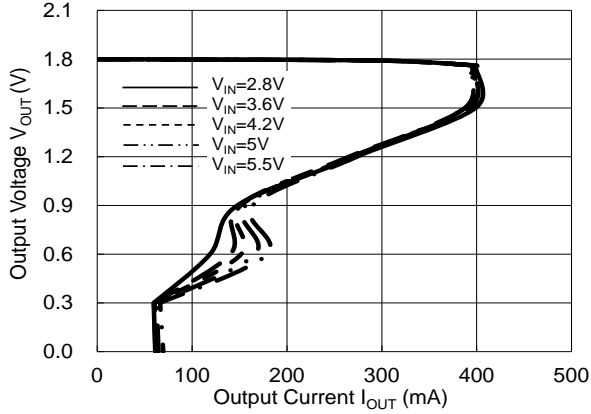

Output Voltage vs. Output Current
AP7315Q-25

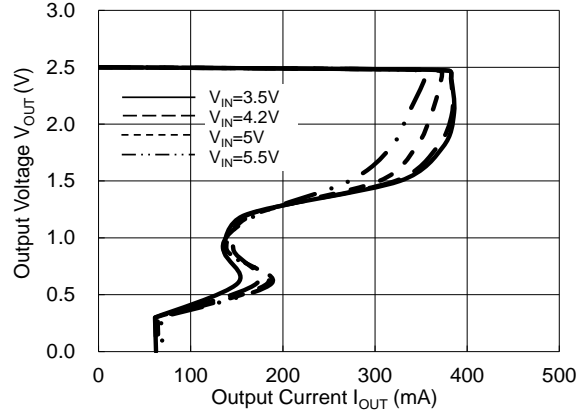

Output Voltage vs. Output Current
AP7315Q-33

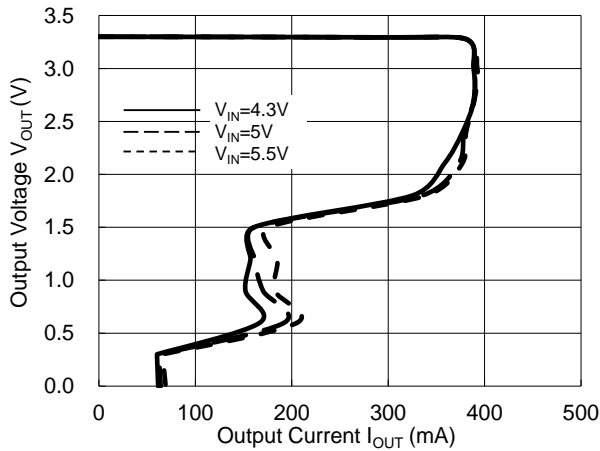

Output Noise (AP7315Q-33)

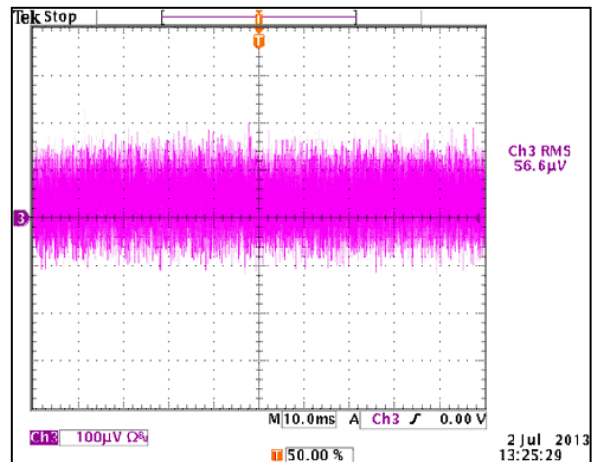

Output Voltage vs. Input Voltage
AP7315Q-25

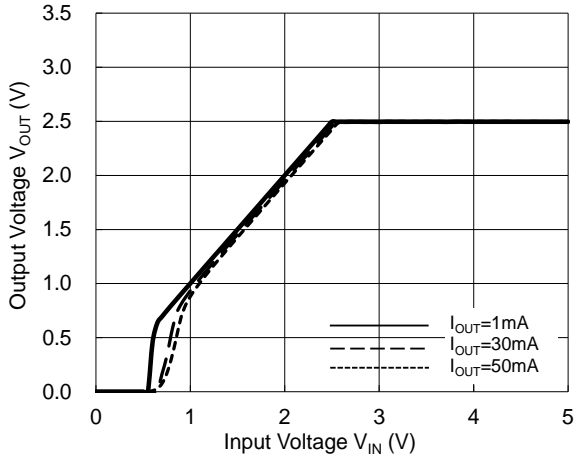

Output Voltage vs. Input Voltage
AP7315Q-33

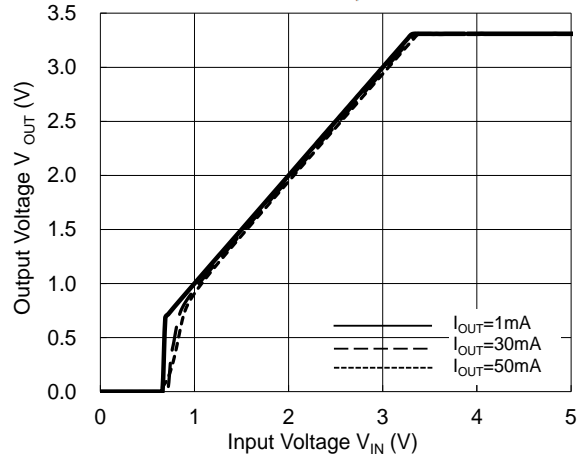

Typical Characteristics (continued)

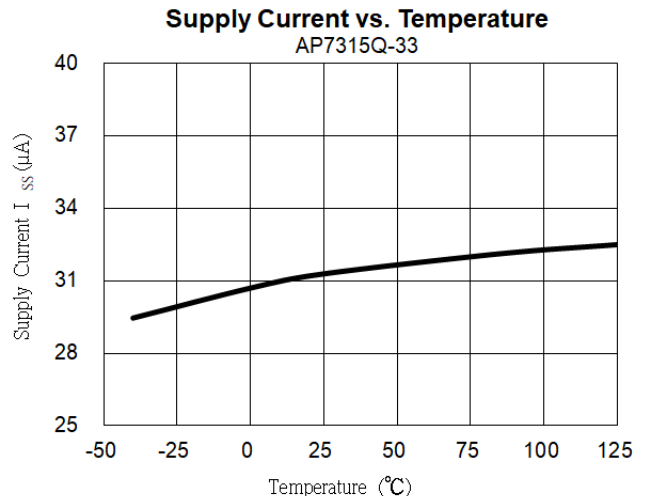
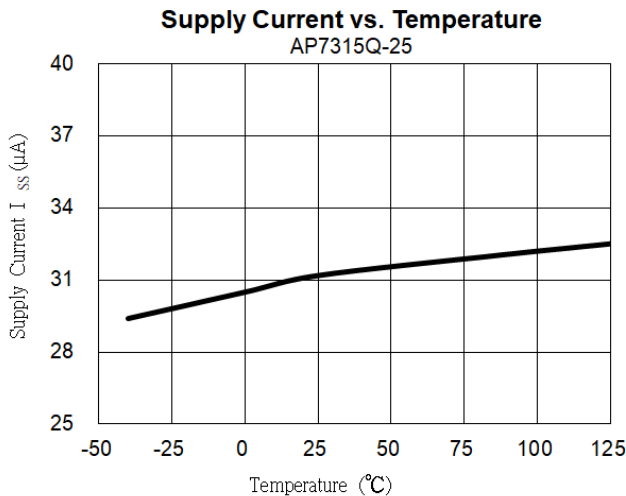
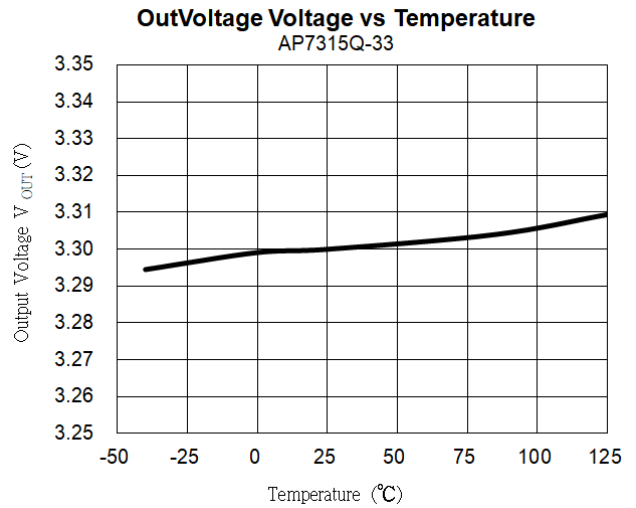
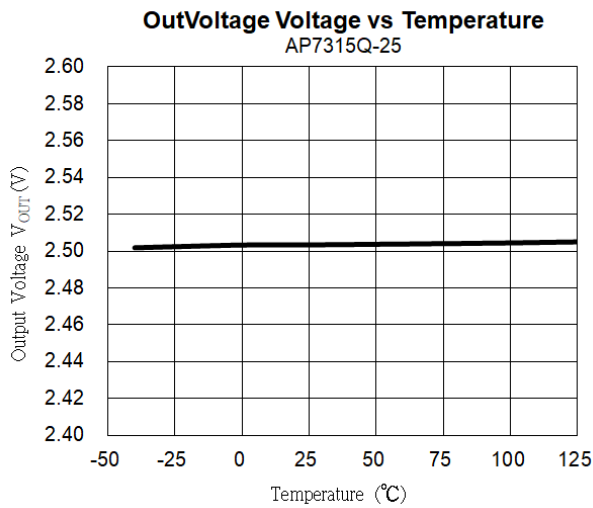
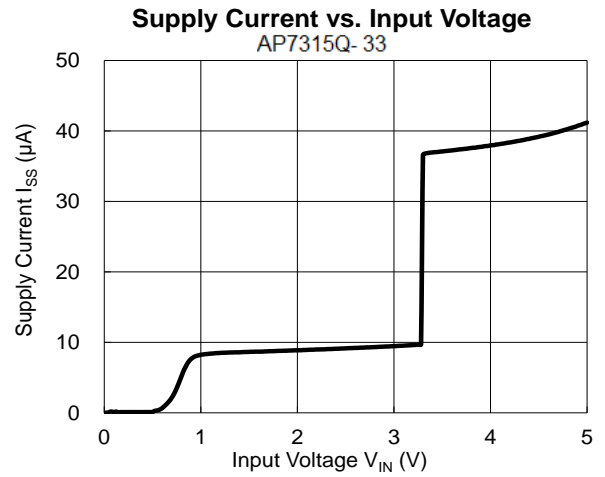
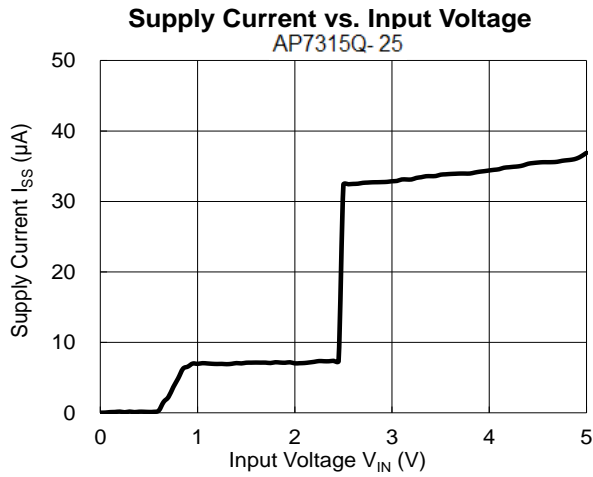

Typical Characteristics (cont.)

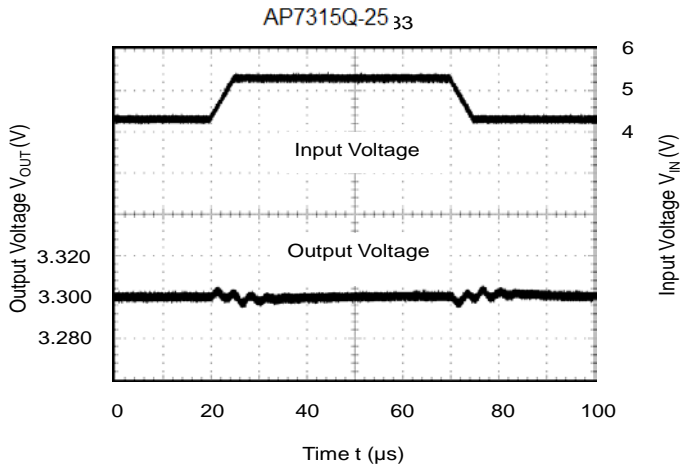
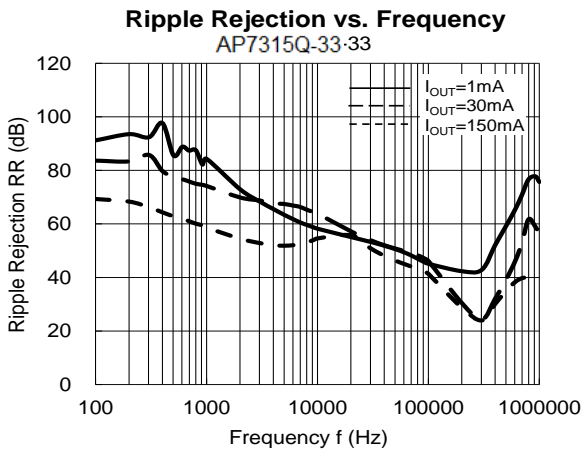
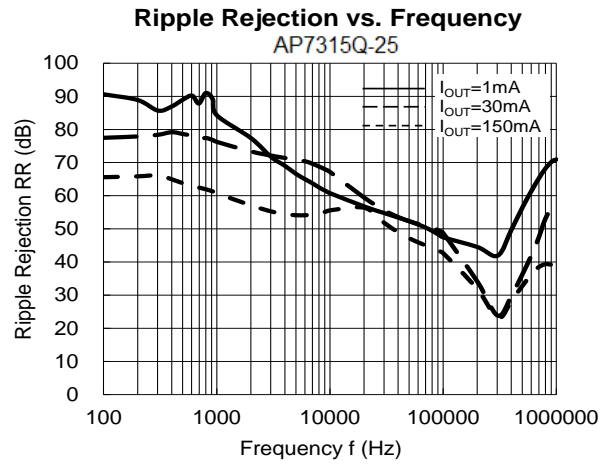
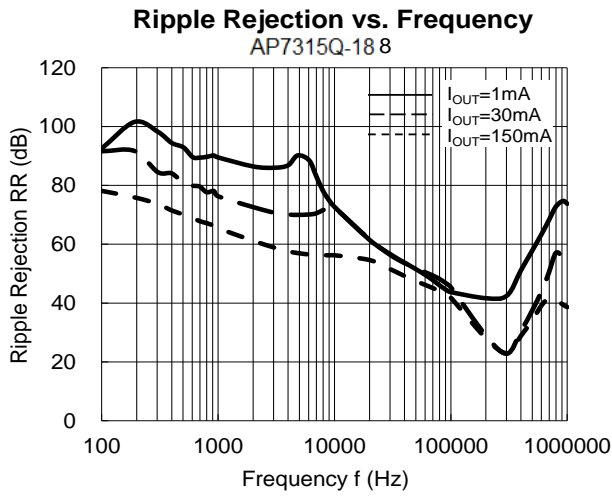

AP7315Q-33

Typical Characteristics (cont.)

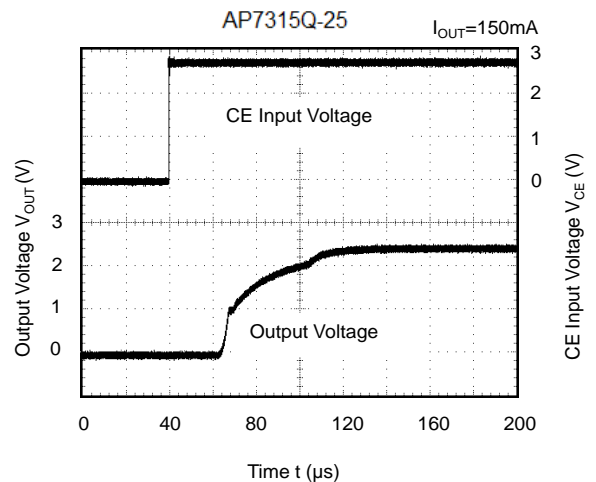
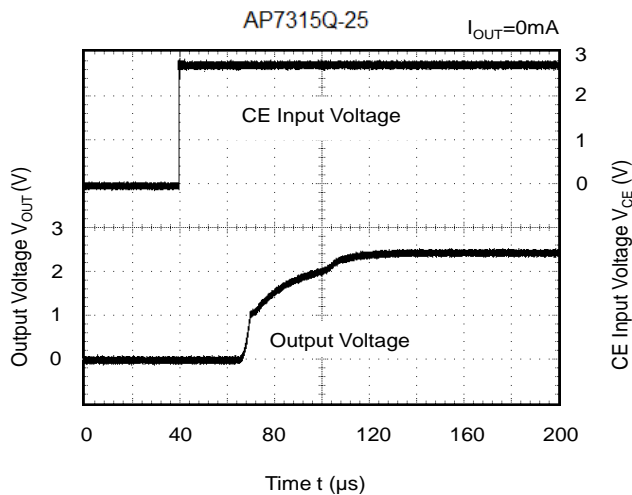
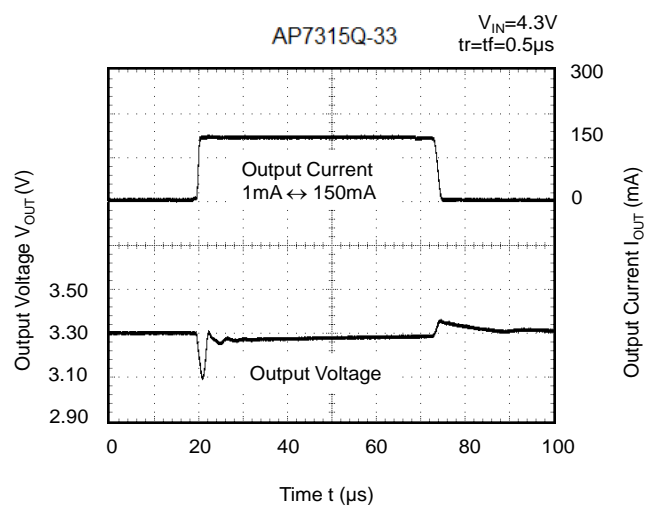
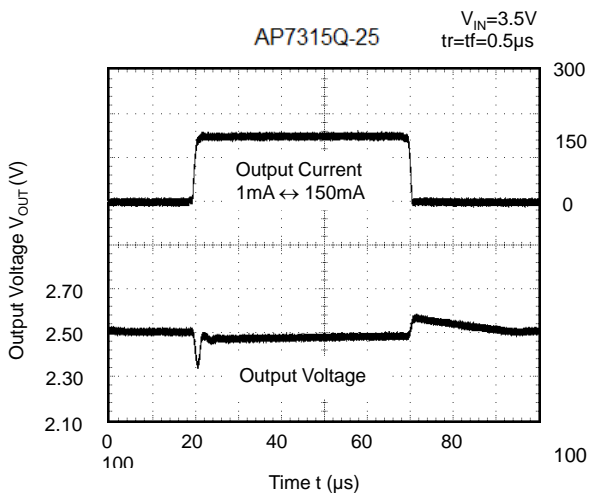
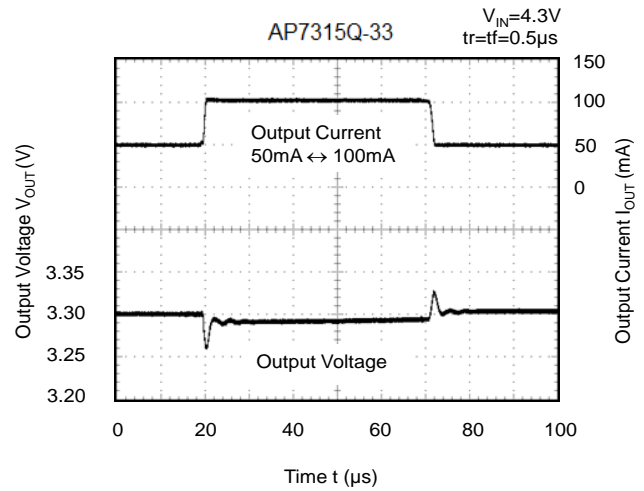
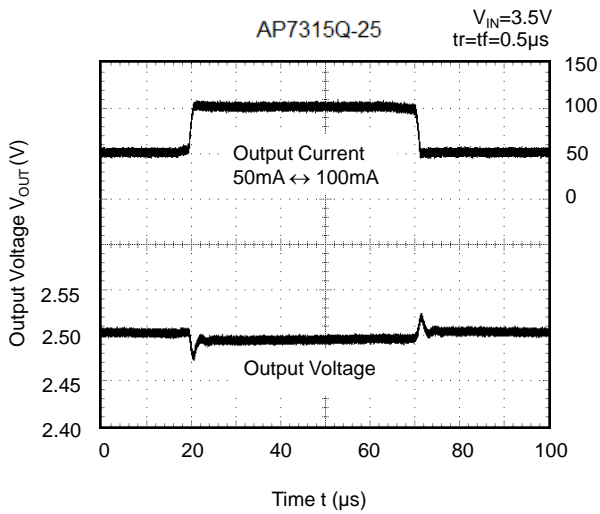

Typical Characteristics (cont.)

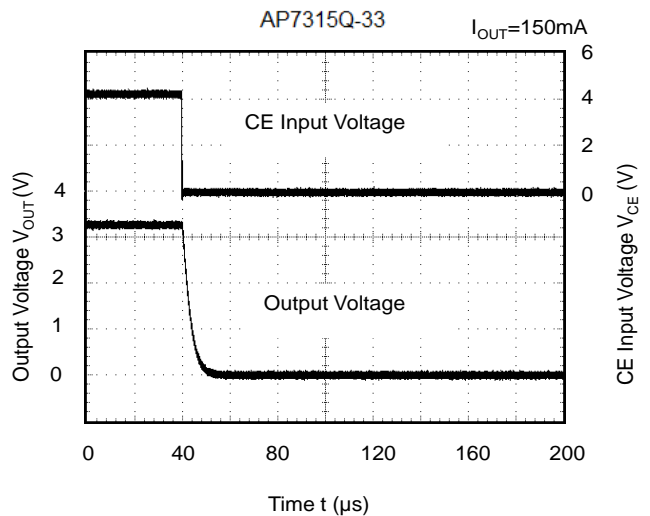
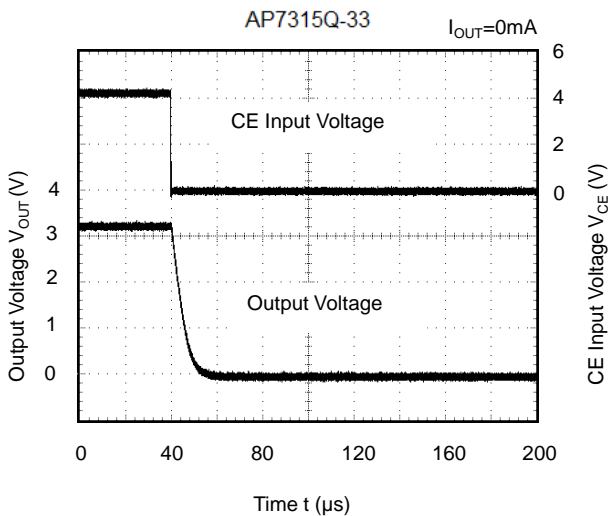
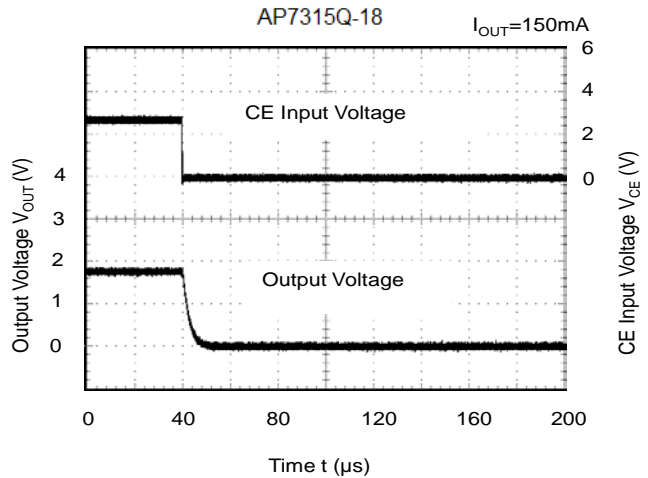
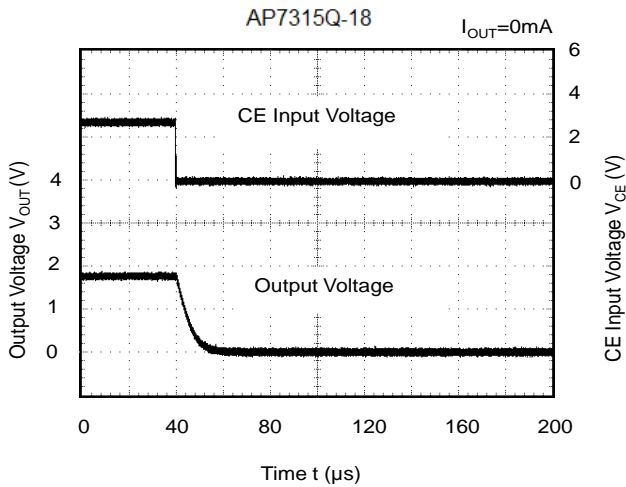
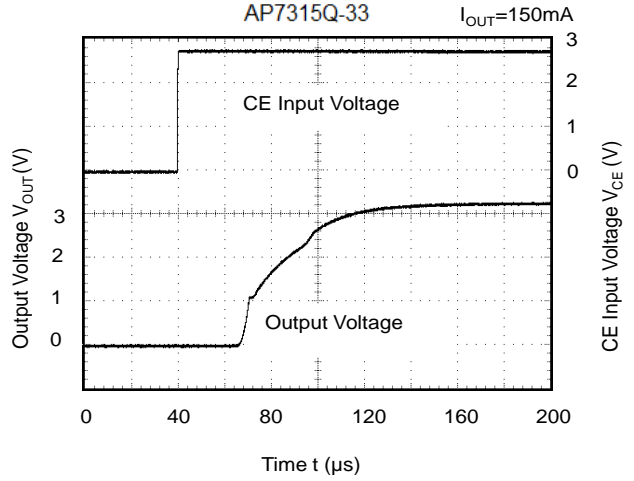
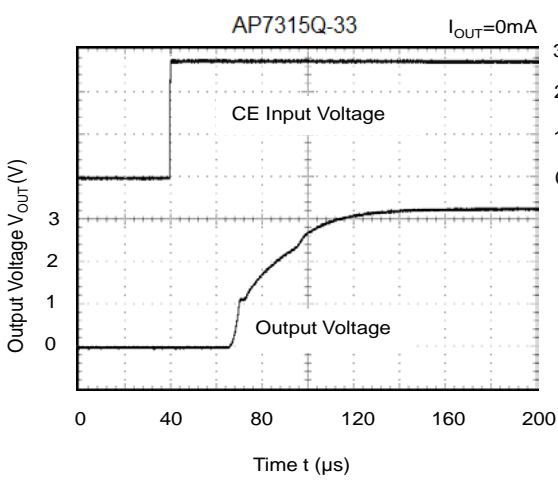

Application Information

Output Capacitor

An output capacitor (C_{OUT}) is required to improve transient response and maintain stability. The AP7315Q is stable with very small ceramic output capacitors. The ESR (equivalent series resistance) and capacitance drives the selection. If the application has large load variations, it is recommended to utilize low-ESR bulk capacitors. It is recommended to place ceramic capacitors as close as possible to the load and the ground pin and care should be taken to reduce the impedance in the layout.

Input Capacitor

To prevent the input voltage from dropping during load steps, it is recommended to utilize an input capacitor (C_{IN}). A minimum 0.47 μ F ceramic capacitor is recommended between V_{IN} and GND pins to decouple input power supply glitch. This input capacitor must be located as close as possible to the device to assure input stability and reduce noise. For PCB layout, a wide copper trace is required for both V_{IN} and GND pins.

Enable Control

The AP7315Q is turned on by setting the EN pin high and is turned off by pulling it low. If this feature is not used, the EN pin should be tied to V_{IN} pin to keep the regulator output on at all time. To ensure proper operation, the signal source used to drive the EN pin must be able to swing above and below the specified turn-on/off voltage thresholds listed in the Electrical Characteristics section.

Short Circuit Protection

When V_{OUT} pin is short-circuit-to-GND, short-circuit protection is triggered and clamp the output current to approximately 60mA. This feature protects the regulator from over-current and damage due to overheating.

Layout Considerations

For good ground loop and stability, the input and output capacitors should be located close to the V_{IN} , V_{OUT} , and GND pins of the device. The regulator GND pin should be connected to the external circuit ground to reduce voltage drop caused by trace impedance. Ground plane is generally used to reduce trace impedance. Wide trace should be used for large current paths from V_{IN} to V_{OUT} , and load circuit.

ESR vs. Output Current

Ceramic type output capacitor is recommended for this series; however, the other output capacitors with low ESR also can be used. The relations between I_{OUT} (Output Current) and ESR of an output capacitor are shown below. The stable region is marked as the hatched area in the graph.

Measurement Conditions:

Frequency Band: 10Hz to 2MHz, Temperature: -40°C to +125°C

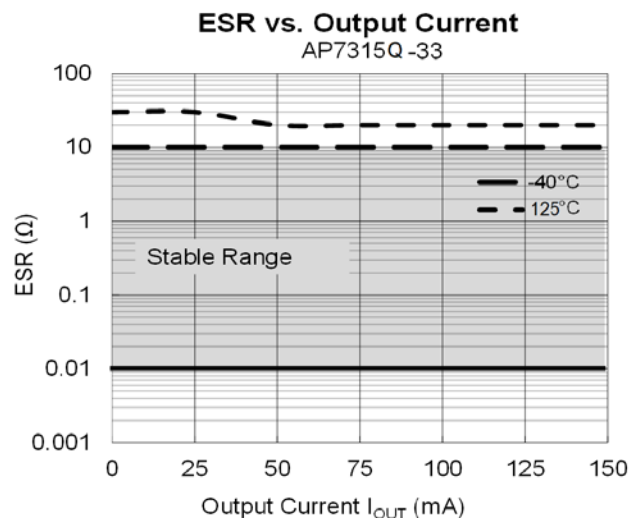
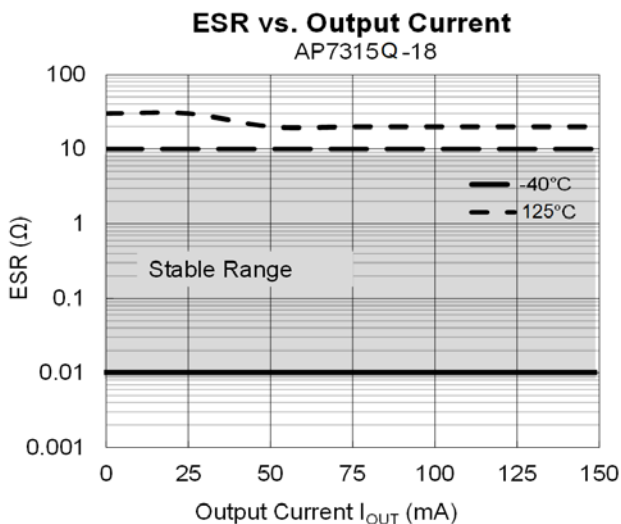

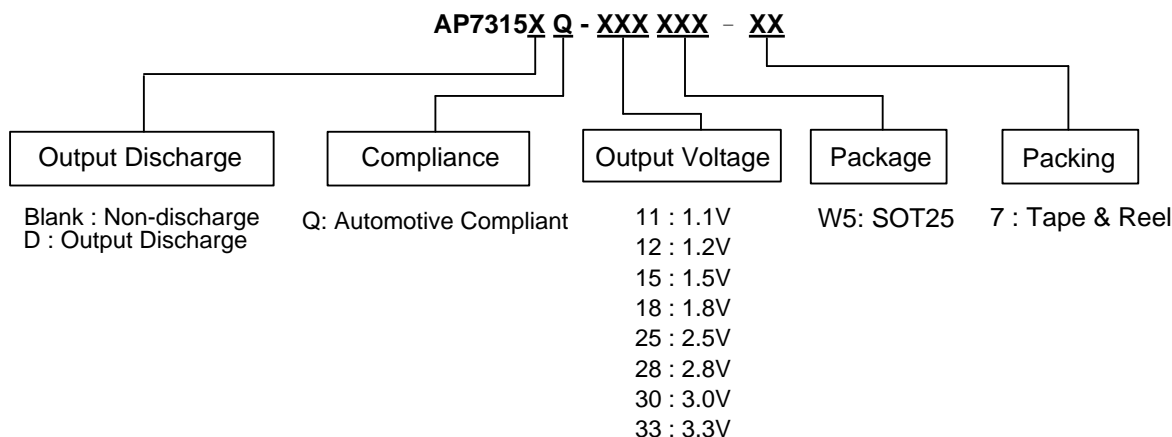
Ordering Information

Part Number (Note 16)	Compliance (Note 17)	Package Code	Packaging (Note 15)	7" Tape and Reel	
				Quantity	Part Number Suffix
AP7315Q-XXW5-7	Automotive Compliant	W5	SOT25	3000/Tape & Reel	-7
AP7315DQ-XXW5-7	Automotive Compliant	W5	SOT25	3000/Tape & Reel	-7

Note: 15. For packaging details, go to our website at <http://www.diodes.com/products/packages.html>.
 16. Other output voltage variants may be available in 100mV steps. For more information, please contact your local Diodes Sales representative.
 17. AP7315Q and AP7315DQ are qualified to AEC-Q100 grade 1 and are classified as Automotive Compliant supporting PPAP documentation. Automotive Compliant and standard products are electrically and thermally the same, except where specified.
 For more information, please refer to http://www.diodes.com/quality/product_compliance_definitions/.
 See AP7315 datasheet for commercial qualified versions.

Marking Information

SOT25

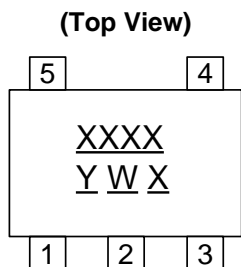

XXXX : Identification Code
Y : Year 0 to 9
W : Week : A to Z : 1 to 26 week;
 a to z : 27 to 52 week; z represents
 52 and 53 week
X : Internal Code

Part Number	Package	Identification Code
AP7315Q-11W5-7	SOT25	15AQ
AP7315Q-12W5-7	SOT25	15BQ
AP7315Q-15W5-7	SOT25	15DQ
AP7315Q-18W5-7	SOT25	15EQ
AP7315Q-25W5-7	SOT25	15JQ
AP7315Q-28W5-7	SOT25	15MQ
AP7315Q-30W5-7	SOT25	15RQ
AP7315Q-33W5-7	SOT25	15UQ
AP7315DQ-11W5-7	SOT25	5DAQ
AP7315DQ-12W5-7	SOT25	5DBQ
AP7315DQ-15W5-7	SOT25	5DDQ
AP7315DQ-18W5-7	SOT25	5DEQ
AP7315DQ-25W5-7	SOT25	5DJQ
AP7315DQ-28W5-7	SOT25	5DMQ
AP7315DQ-30W5-7	SOT25	5DSQ
AP7315DQ-33W5-7	SOT25	5DVQ

Package Outline Dimensions

Please see <http://www.diodes.com/package-outlines.html> for the latest version.

SOT25

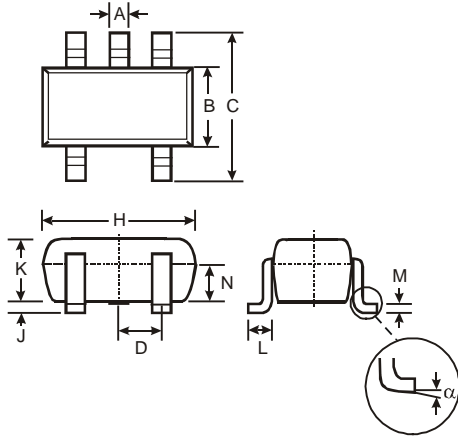

SOT25			
Dim	Min	Max	Typ
A	0.35	0.50	0.38
B	1.50	1.70	1.60
C	2.70	3.00	2.80
D	-	-	0.95
H	2.90	3.10	3.00
J	0.013	0.10	0.05
K	1.00	1.30	1.10
L	0.35	0.55	0.40
M	0.10	0.20	0.15
N	0.70	0.80	0.75
α	0°	8°	-
All Dimensions in mm			

Suggested Pad Layout

Please see <http://www.diodes.com/package-outlines.html> for the latest version.

SOT25

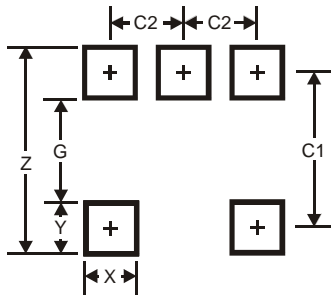

Dimensions	Value
Z	3.20
G	1.60
X	0.55
Y	0.80
C1	2.40
C2	0.95

IMPORTANT NOTICE

DIODES INCORPORATED MAKES NO WARRANTY OF ANY KIND, EXPRESS OR IMPLIED, WITH REGARDS TO THIS DOCUMENT, INCLUDING, BUT NOT LIMITED TO, THE IMPLIED WARRANTIES OF MERCHANTABILITY AND FITNESS FOR A PARTICULAR PURPOSE (AND THEIR EQUIVALENTS UNDER THE LAWS OF ANY JURISDICTION).

Diodes Incorporated and its subsidiaries reserve the right to make modifications, enhancements, improvements, corrections or other changes without further notice to this document and any product described herein. Diodes Incorporated does not assume any liability arising out of the application or use of this document or any product described herein; neither does Diodes Incorporated convey any license under its patent or trademark rights, nor the rights of others. Any Customer or user of this document or products described herein in such applications shall assume all risks of such use and will agree to hold Diodes Incorporated and all the companies whose products are represented on Diodes Incorporated website, harmless against all damages.

Diodes Incorporated does not warrant or accept any liability whatsoever in respect of any products purchased through unauthorized sales channel. Should Customers purchase or use Diodes Incorporated products for any unintended or unauthorized application, Customers shall indemnify and hold Diodes Incorporated and its representatives harmless against all claims, damages, expenses, and attorney fees arising out of, directly or indirectly, any claim of personal injury or death associated with such unintended or unauthorized application.

Products described herein may be covered by one or more United States, international or foreign patents pending. Product names and markings noted herein may also be covered by one or more United States, international or foreign trademarks.

This document is written in English but may be translated into multiple languages for reference. Only the English version of this document is the final and determinative format released by Diodes Incorporated.

LIFE SUPPORT

Diodes Incorporated products are specifically not authorized for use as critical components in life support devices or systems without the express written approval of the Chief Executive Officer of Diodes Incorporated. As used herein:

A. Life support devices or systems are devices or systems which:

1. are intended to implant into the body, or
2. support or sustain life and whose failure to perform when properly used in accordance with instructions for use provided in the labeling can be reasonably expected to result in significant injury to the user.

B. A critical component is any component in a life support device or system whose failure to perform can be reasonably expected to cause the failure of the life support device or to affect its safety or effectiveness.

Customers represent that they have all necessary expertise in the safety and regulatory ramifications of their life support devices or systems, and acknowledge and agree that they are solely responsible for all legal, regulatory and safety-related requirements concerning their products and any use of Diodes Incorporated products in such safety-critical, life support devices or systems, notwithstanding any devices- or systems-related information or support that may be provided by Diodes Incorporated. Further, Customers must fully indemnify Diodes Incorporated and its representatives against any damages arising out of the use of Diodes Incorporated products in such safety-critical, life support devices or systems.

Copyright © 2019, Diodes Incorporated

www.diodes.com



Компания «ЭлектроПласт» предлагает заключение долгосрочных отношений при поставках импортных электронных компонентов на взаимовыгодных условиях!

Наши преимущества:

- Оперативные поставки широкого спектра электронных компонентов отечественного и импортного производства напрямую от производителей и с крупнейших мировых складов;
- Поставка более 17-ти миллионов наименований электронных компонентов;
- Поставка сложных, дефицитных, либо снятых с производства позиций;
- Оперативные сроки поставки под заказ (от 5 рабочих дней);
- Экспресс доставка в любую точку России;
- Техническая поддержка проекта, помощь в подборе аналогов, поставка прототипов;
- Система менеджмента качества сертифицирована по Международному стандарту ISO 9001;
- Лицензия ФСБ на осуществление работ с использованием сведений, составляющих государственную тайну;
- Поставка специализированных компонентов (Xilinx, Altera, Analog Devices, Intersil, Interpoint, Microsemi, Aeroflex, Peregrine, Syfer, Eurofarad, Texas Instrument, Miteq, Cobham, E2V, MA-COM, Hittite, Mini-Circuits, General Dynamics и др.);

Помимо этого, одним из направлений компании «ЭлектроПласт» является направление «Источники питания». Мы предлагаем Вам помощь Конструкторского отдела:

- Подбор оптимального решения, техническое обоснование при выборе компонента;
- Подбор аналогов;
- Консультации по применению компонента;
- Поставка образцов и прототипов;
- Техническая поддержка проекта;
- Защита от снятия компонента с производства.

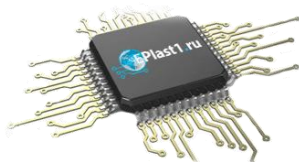

Как с нами связаться

Телефон: 8 (812) 309 58 32 (многоканальный)

Факс: 8 (812) 320-02-42

Электронная почта: org@eplast1.ru

Адрес: 198099, г. Санкт-Петербург, ул. Калинина, дом 2, корпус 4, литера А.