



18W Medical Grade Adapter



Features

- Meets DoE Level VI
- IEC60601-1:2005+A1:2012 2xMOPP approved
- IEC60601-1-2 Ed4 2014 compliance
- Suitable for BF applications with system consideration
- OVP, OCP, SCP, OTP, brown-in and brown out protections
- LPS compliant

Applications

- CPAP & BIPAP machines
- Medical imaging
- Nebulizers
- Blood pressure monitor

Safety Approvals

- UL 60601-1
- IEC60601-1

Mechanical Characteristics

- Length: 82mm (3.23in)
- Width: 43.2mm (1.7in)
- Height: 30mm (1.18in)

Output Specifications

Model	DC Output Voltage	Load		Ripple ⁽¹⁾ P-P (max.)	Regulation Line & Load	Case Color
		Min.	Max.			
PMA18A-120PHW-R	12V	0A	1.5A	150mV	±5%	White

Notes: (1)Test by 20Mhz bandwidth mode hi resolution with 10uF and 0.1uF capacitor

Phihong is not responsible for any error, and reserves the right to make changes without notice. Please visit our website at www.phihong.com for the most up-to-date specifications and contact information.

Input:**AC Input Voltage Rating**

110 to 240V AC

AC Input Voltage Range

100 to 240V AC

AC Input Frequency

50 to 60Hz

Input Current

0.6A ~ 0.25A at 100VAC ~ 240VAC

Leakage Current

<100uA at 264VAC/50Hz

Inrush Current

80A maximum at 240V AC

(Cold start & at input rated voltage +/-12.5%)

Output:**Efficiency**

DOE Level VI

Environmental:**Temperature**

Operation 10°C to +40°C

Non-operation -20°C to +80°C

Relative Humidity 95% RH Max

Emissions

Complies with FCC Class B

Complies with EN55032 Class B

Immunity

ESD: EN 61000-4-2

RS : EN61000-4-3

EFT/Burst : EN61000-4-4

Surge: EN 61000-4-5

CS : EN61000-4-6

Power Frequency Magnetic Field : EN61000-4-8

Voltage Dips : EN61000-4-11

Over-Voltage Protection

16V maximum

Short-Circuit Protection

The power supply shall be protected when operating any output in overload condition, or when operating any output in a short. The power supply shall be self-recovering when the fault condition is removed circuit condition.

Over-Current Protection

The power supply will be protected when output power at 2.2A(min) of all rated dc output

Over-Temperature Protection

Over-temperature protection sensor

Dielectric Withstand (Hi-pot) Test

Pri. to Sec. >4000VAC 10mA for 1 Minute

DC Output Connector

DC plug type 5.5 x 2.1 x 10mm (fork & groove)

DC plug pin assignment: Inner (+V), Outer GND(-)

Dimension Diagram Unit: mm (inch)

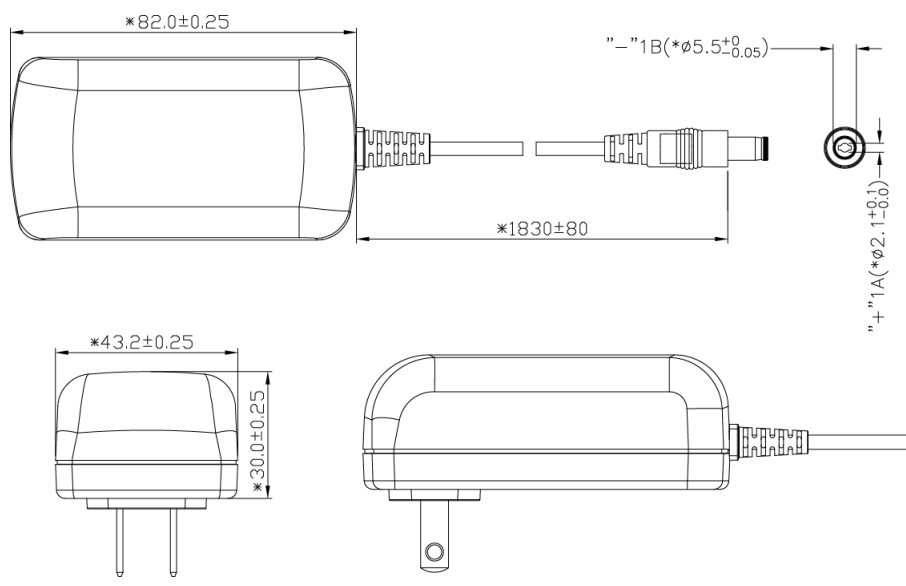

**Supplier's Declaration of Conformity
47 CFR § 2.1077 Compliance Information**

Phihong USA Corporation
47800 Fremont Boulevard
Fremont, CA 94538
Telephone: (510) 445-0100
www.phihong.com

NOTE: This model has/The models in this product series have been tested and found to comply with the limits for a Class B digital device, pursuant to part 15 of the FCC Rules. These limits are designed to provide reasonable protection against harmful interference in a residential installation. This equipment generates, uses and can radiate radio frequency energy and, if not installed and used in accordance with the instructions, may cause harmful interference to radio communications. However, there is no guarantee that interference will not occur in a particular installation. If this equipment does cause harmful interference to radio or television reception, which can be determined by turning the equipment off and on, the user is encouraged to try to correct the interference by one or more of the following measures:

- Reorient or relocate the receiving antenna.
- Increase the separation between the equipment and receiver.
- Connect the equipment into an outlet on a circuit different from that to which the receiver is connected.
- Consult the dealer or an experienced radio/TV technician for help.

Changes or modifications to equipment not expressly approved by PHIHONG could void the user's authority to operate the equipment.



Компания «ЭлектроПласт» предлагает заключение долгосрочных отношений при поставках импортных электронных компонентов на взаимовыгодных условиях!

Наши преимущества:

- Оперативные поставки широкого спектра электронных компонентов отечественного и импортного производства напрямую от производителей и с крупнейших мировых складов;
- Поставка более 17-ти миллионов наименований электронных компонентов;
- Поставка сложных, дефицитных, либо снятых с производства позиций;
- Оперативные сроки поставки под заказ (от 5 рабочих дней);
- Экспресс доставка в любую точку России;
- Техническая поддержка проекта, помощь в подборе аналогов, поставка прототипов;
- Система менеджмента качества сертифицирована по Международному стандарту ISO 9001;
- Лицензия ФСБ на осуществление работ с использованием сведений, составляющих государственную тайну;
- Поставка специализированных компонентов (Xilinx, Altera, Analog Devices, Intersil, Interpoint, Microsemi, Aeroflex, Peregrine, Syfer, Eurofarad, Texas Instrument, Miteq, Cobham, E2V, MA-COM, Hittite, Mini-Circuits, General Dynamics и др.);

Помимо этого, одним из направлений компании «ЭлектроПласт» является направление «Источники питания». Мы предлагаем Вам помощь Конструкторского отдела:

- Подбор оптимального решения, техническое обоснование при выборе компонента;
- Подбор аналогов;
- Консультации по применению компонента;
- Поставка образцов и прототипов;
- Техническая поддержка проекта;
- Защита от снятия компонента с производства.



Как с нами связаться

Телефон: 8 (812) 309 58 32 (многоканальный)

Факс: 8 (812) 320-02-42

Электронная почта: org@eplast1.ru

Адрес: 198099, г. Санкт-Петербург, ул. Калинина, дом 2, корпус 4, литера А.