

20W RX DUAL MODE WIRELESS CHARGING COIL

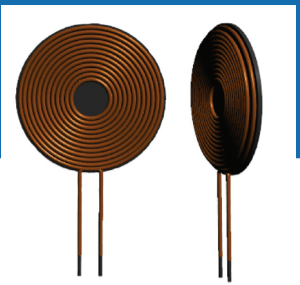

AWCCA-RX350300-101

Ø 35.00 x 3.0 mm

 **RoHS/RoHS II Compliant**
MSL= 1

FEATURES

- Wireless charging receiver coil
- Optimized for 19V/20W operation
- 25uH inductance
- 35mm diameter
- 3.0mm height
- High permeability shielding to protect sensitive electronics
- Durable construction
- Industrial -40°C to 85°C operating temperature
- Compatible with Semtech's high power 20W wireless charging receiver (TSDMRX-19V/20W-EVM)

APPLICATIONS

- Industrial automation
- Medical devices
- Portable audio/video
- Robotics
- Drones
- Appliances
- Power tools

MAXIMUM RATINGS

Item	Value
Operating Temperature Range	T = -25°C ~ 85°C, RH 65±20%
Storage Temperature Range	T = -40°C~85°C, RH 65±20%

ELECTRICAL SPECIFICATIONS

Part Number	Inductance	DC Resistance	Q
AWCCA-RX350300-101	25µH±10%	170mΩ Max	85 Typ
Test Condition	100KHz / 1V	20±15°C	100KHz/1V
Test Equipment	HP4284A, HP42841A , Agilent 34420A or equivalent		
Test Environment	Temperature: 20±15°C, RH: 65% ±20%.		

Test Conditions: Ambient Temperature: 20±10°C, RH: 65% ±20%.

PART IDENTIFICATION

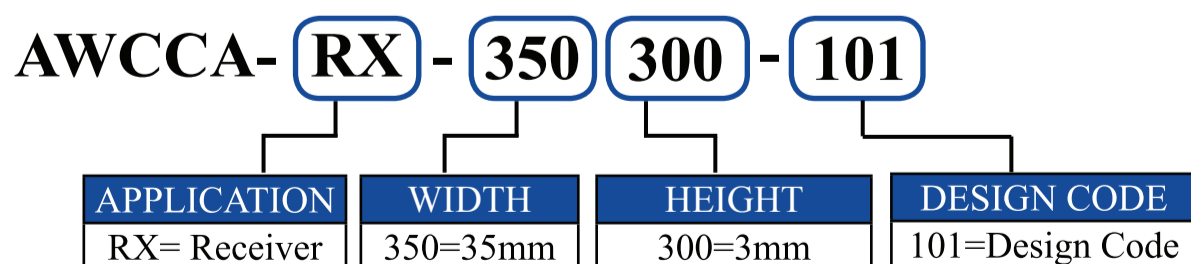

REVISED: 08/07/2018



5101 Hidden Creek Lane Spicewood TX 78669
Phone: 512-371-6159 | Fax: 512-351-8858
For terms and conditions of sale please visit:
www.abracon.com

ABRACON IS
ISO9001-2015
CERTIFIED

20W RX DUAL MODE WIRELESS CHARGING COIL

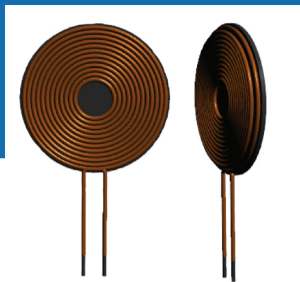

AWCCA-RX350300-101

Ø 35.00 x 3.0 mm

RoHS/RoHS II Compliant

MSL= 1

MECHANICAL DIMENSIONS (ALL DIMENSIONS ARE IN mm)

Tolerances are ±0.2mm, unless otherwise specified*

Dimensions of AWCCA-RX350300-101

Item	A	B	C	D	E	F	G	H
Spec	11.00	33.00	35.00	35.00	5.00	1.00	3.00	5.00
Tol	±0.5	±1.00	±0.80	±2.00	±2.00	±0.08	MAX	±1.50

Winding Details of AWCCA-RX350300-101

Number of Coils	Wire	Number of Turns	Inductance
1	USTC Wire Φ0.08 mm*50	13.5 Turns, 2 layer	25µH±10%
Magnetic Sheet		Format	
Soft Ferrite		1 layer / Φ35.0mm x 1.00mm	

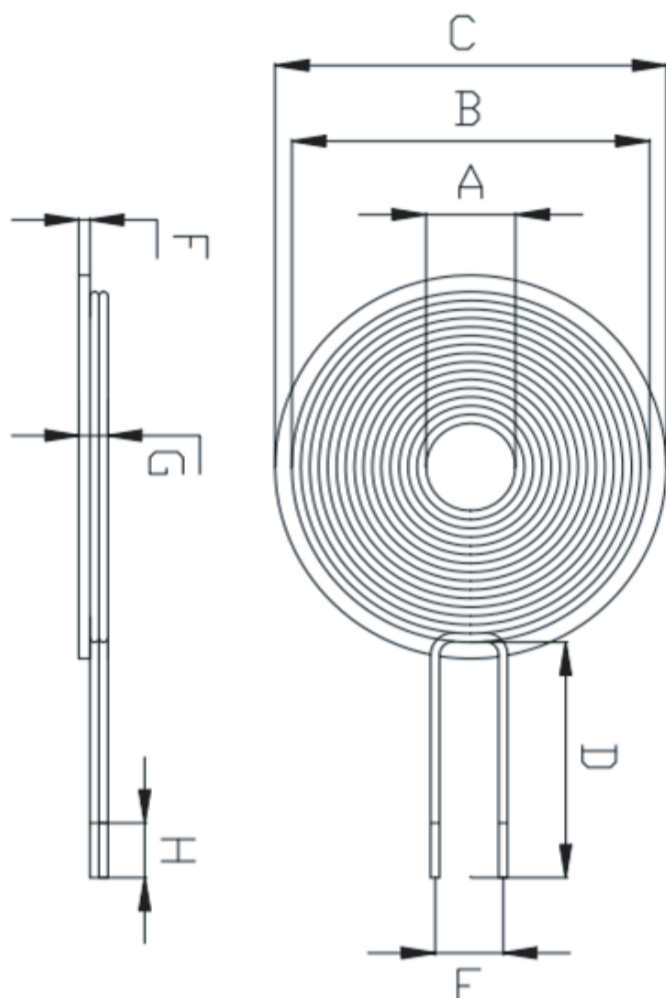

Wave Soldering Profile: Not suitable for wave soldering

Manual Soldering: 350°C Max, 3secs

Packaging: Tray packaging: 15 per grid, 300pcs per tray

Weight approximately: 2.8Kg

Tray dimensions 395 x 258 x 60mm

Carton packaging: 4 trays per carton, 1200pcs per carton

Weight approximately: 12Kg

Carton dimensions: 395 x 285 x 275mm

STORAGE AND OPERATIONAL CONDITIONS

Storage Conditions

1. Recommended storage conditions: -40°C~85°C, RH 65±20%
2. Service life: 12 Month @ 40°C, RH 40 ~ 65%
3. The appearance and solder ability should be check, if product is not in expiry date.

Operation Conditions

1. Use condition limit: T= -25°C ~ 85°C, RH 65±20%

REVISED: 08/07/2018

20W RX DUAL MODE WIRELESS CHARGING COIL

AWCCA-RX350300-101

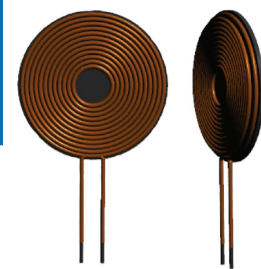

Ø 35.00 x 3.0 mm



RoHS/RoHS II Compliant

MSL= 1

NOTES

1. The parts are manufactured in accordance with this specification. If other conditions and specifications which are required for this specification, please contact ABRACON for more information.
2. ABRACON will supply the parts in accordance with this specification unless we receive a written request to modify prior to an order placement.
3. In no case shall ABRACON be liable for any product failure from in appropriate handling or operation of the item beyond the scope of this specification.
4. When changing your production process, please notify ABRACON immediately.
5. ABRACON LLC's products are COTS – Commercial-Off-The-Shelf products; suitable for Commercial, Industrial and, where designated, Automotive Applications. ABRACON's products are not specifically designed for Military, Aviation, Aerospace, Life-dependant Medical applications or any application requiring high reliability where component failure could result in loss of life and/or property. For applications requiring high reliability and/or presenting an extreme operating environment, written consent and authorization from ABRACON LLC is required. Please contact ABRACON LLC for more information.
6. All specifications and Marking will be subject to change without notice.

REVISED: 08/07/2018



5101 Hidden Creek Lane Spicewood TX 78669
Phone: 512-371-6159 | Fax: 512-351-8858
For terms and conditions of sale please visit:
www.abracon.com

ABRACON IS
ISO9001-2015
CERTIFIED



Компания «ЭлектроПласт» предлагает заключение долгосрочных отношений при поставках импортных электронных компонентов на взаимовыгодных условиях!

Наши преимущества:

- Оперативные поставки широкого спектра электронных компонентов отечественного и импортного производства напрямую от производителей и с крупнейших мировых складов;
- Поставка более 17-ти миллионов наименований электронных компонентов;
- Поставка сложных, дефицитных, либо снятых с производства позиций;
- Оперативные сроки поставки под заказ (от 5 рабочих дней);
- Экспресс доставка в любую точку России;
- Техническая поддержка проекта, помощь в подборе аналогов, поставка прототипов;
- Система менеджмента качества сертифицирована по Международному стандарту ISO 9001;
- Лицензия ФСБ на осуществление работ с использованием сведений, составляющих государственную тайну;
- Поставка специализированных компонентов (Xilinx, Altera, Analog Devices, Intersil, Interpoint, Microsemi, Aeroflex, Peregrine, Syfer, Eurofarad, Texas Instrument, Miteq, Cobham, E2V, MA-COM, Hittite, Mini-Circuits, General Dynamics и др.);

Помимо этого, одним из направлений компании «ЭлектроПласт» является направление «Источники питания». Мы предлагаем Вам помощь Конструкторского отдела:

- Подбор оптимального решения, техническое обоснование при выборе компонента;
- Подбор аналогов;
- Консультации по применению компонента;
- Поставка образцов и прототипов;
- Техническая поддержка проекта;
- Защита от снятия компонента с производства.



Как с нами связаться

Телефон: 8 (812) 309 58 32 (многоканальный)

Факс: 8 (812) 320-02-42

Электронная почта: org@eplast1.ru

Адрес: 198099, г. Санкт-Петербург, ул. Калинина, дом 2, корпус 4, литера А.