

Smart High-Side Power Switch for Industrial Applications

One channel: 1 x 1 Ω

Features

- Current controlled input
- Short circuit protection
- Current limitation
- Overload protection
- Overvoltage protection (including load dump)
- Switching inductive loads
- Clamp of negative voltage at output with inductive loads
- Thermal shutdown with restart
- ESD – Protection
- Loss of GND and loss of V_{bb} protection
- Very low standby current
- Reverse battery protection
- Improved electromagnetic compatibility (EMC)

Product Summary

Overvoltage protection	$V_{bbin(AZ)}$	62	V
Operating voltage	$V_{bb(on)}$	4,9...60	V
On-state resistance	R_{ON}	1	Ω
Operating Temperature	T_a	-30 ... +85	$^{\circ}\text{C}$

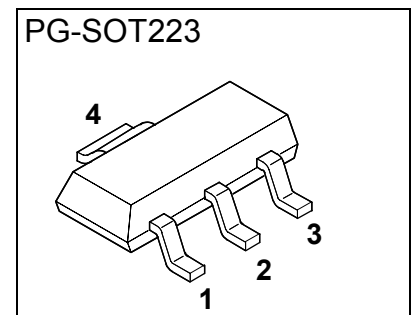

Application

- All types of resistive, inductive and capacitive loads in industrial applications
- Current controlled power switch for 12V, 24V and 42V DC industrial applications
- Driver for electromagnetic relays
- Signal amplifier

General Description

- N channel vertical power MOSFET with charge pump and current controlled input, monolithically integrated in Smart SIPMOS[®] technology.
- Providing embedded protection functions.

Type	Ordering code	Package
ITS 4140N	SP000240073	PG-SOT223

Block Diagram

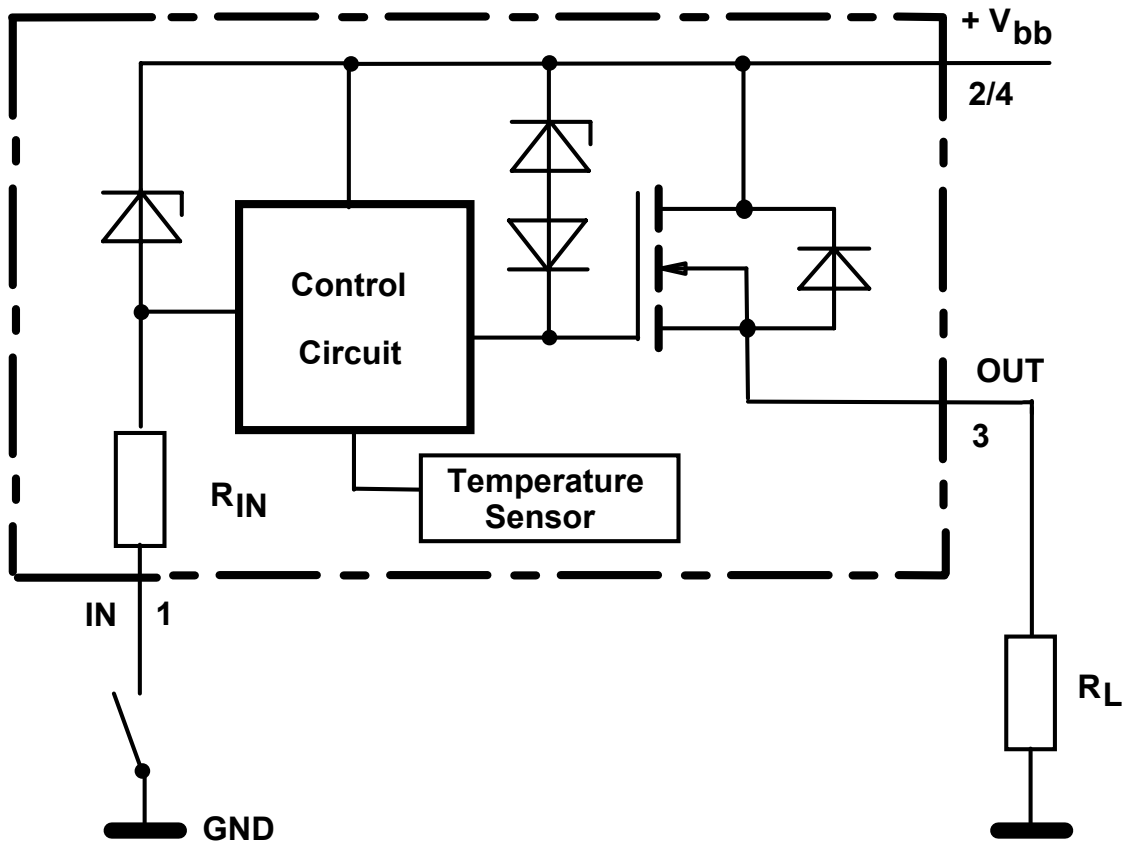

Pin	Symbol	Function
1	IN	Input, activates the power switch in case of connection to GND
2	Vbb	Positive power supply voltage
3	OUT	Output to the load
4	Vbb	Positive power supply voltage

Maximum Ratings

Parameter at $T_j = 25^\circ\text{C}$ unless otherwise specified	Symbol	Values	Unit
Supply voltage	V_{bb}	60	V
Load current (Short – circuit current, see page 5)	I_L	self limited	A
Maximum current through the input pin (DC)	I_{IN}	± 15	mA
Junction temperature	T_j	+150	$^\circ\text{C}$
Operating temperature range	T_a	-30 ... +85	
Storage temperature range	T_{stg}	-40 ... +105	
Power dissipation ¹⁾ $T_a = 25^\circ\text{C}$	P_{tot}	1.7	W
Inductive load switch-off energy dissipation ²⁾ Single pulse $T_j = 150^\circ\text{C}$, $I_L = 0.15\text{A}$	E_{AS}	1	J
Load dump protection ³⁾ $V_{LoadDump}^{4)} = V_A + V_S$ $R_L = 2\Omega$, $t_d = 400\text{ms}$, $V_{IN} = \text{low or high}$ $I_L = 150\text{mA}$, $V_{bb} = 13.5\text{V}$ $V_{bb} = 27\text{V}$	$V_{LoadDump}$	93.5 127	V
Electrostatic discharge voltage (Human Body Model) According to ANSI EOS/ESD – S5.1 – 1993 ESD STM5.1 – 1998 Input pin all other pins	V_{ESD}	± 1 ± 5	kV

¹⁾ Device on 50mm*50mm*1.5mm epoxy PCB FR4 with 6 cm² (one layer, 70 μm thick) copper area for V_{bb} connection. PCB is vertical without blown air.

²⁾ Not subject to production test, specified by design

³⁾ More details see EMC-Characteristics on page 7

⁴⁾ $V_{LoadDump}$ is setup without the DUT connected to the generator per ISO 7637-1 and DIN 40839.

Electrical Characteristics

Parameter	Symbol	Values			Unit
		min.	typ.	max.	
at $T_j = -40 \dots 150 \text{ }^\circ\text{C}$, $V_{bb} = 9 \dots 42 \text{ V}$ unless otherwise specified					

Thermal Characteristics

Thermal resistance @ min. footprint	$R_{th(JA)}$	-	86	125	K/W
Thermal resistance @ 6 cm ² cooling area ¹⁾	$R_{th(JA)}$	-	60	72	
Thermal resistance, junction - soldering point	$R_{th(JS)}$	-	-	17	K/W

Load Switching Capabilities and Characteristics

On-state resistance Pin1 connected to GND $T_j = 25 \text{ }^\circ\text{C}$, $I_L = 150 \text{ mA}$, $V_{bb} = 9 \dots 52 \text{ V}$ $T_j = 150 \text{ }^\circ\text{C}$ $T_j = 25 \text{ }^\circ\text{C}$, $I_L = 50 \text{ mA}$, $V_{bb} = 6 \text{ V}$	R_{ON}	-	1 1.5 2	1.5 3 5	Ω
Nominal load current ²⁾ Device on PCB ¹⁾ $T_a = 85 \text{ }^\circ\text{C}$, $T_j \leq 150 \text{ }^\circ\text{C}$	$I_{L(nom)}$	0.2	-	-	
Turn-on time ³⁾ $V_{IN} = V_{bb}$ to 0V to 90% V_{OUT} $R_L = 270 \text{ } \Omega$ $R_L = 270 \text{ } \Omega$, $V_{bb} = 13.5 \text{ V}$, $T_j = 25 \text{ }^\circ\text{C}$	t_{on}	-	- 45	125 ⁴⁾ 100	μs
Turn-off time ³⁾ $V_{IN} = 0\text{V}$ to V_{bb} to 10% V_{OUT} $R_L = 270 \text{ } \Omega$ $R_L = 270 \text{ } \Omega$, $V_{bb} = 13.5 \text{ V}$, $T_j = 25 \text{ }^\circ\text{C}$	t_{off}	-	- 40	175 ⁴⁾ 140	
Slew rate on ³⁾ $V_{IN} = V_{bb}$ to 0V 10 to 30% V_{OUT} $R_L = 270 \text{ } \Omega$ $R_L = 270 \text{ } \Omega$, $T_j = 25 \text{ }^\circ\text{C}$, $V_{bb} = 13.5 \text{ V}$	dV/dt_{on}	-	- 1.3	6 ⁴⁾ 4	V/ μs
Slew rate off ³⁾ $V_{IN} = 0\text{V}$ to V_{bb} 70 to 40% V_{OUT} $R_L = 270 \text{ } \Omega$ $R_L = 270 \text{ } \Omega$, $T_j = 25 \text{ }^\circ\text{C}$, $V_{bb} = 13.5 \text{ V}$	$-dV/dt_{off}$	-	- 1.7	8 ⁴⁾ 4	

¹⁾Device on 50mm*50mm*1.5mm epoxy PCB FR4 with 6 cm² (one layer, 70 μm thick) copper area for V_{bb} connection. PCB is vertical without blown air.

²⁾Nominal load current is limited by the current limitation (see page 5)

³⁾Timing values only with high input slewrates, otherwise slower.

⁴⁾not subject to production test, specified by design

Electrical Characteristics

Parameter at $T_j = -40...150\text{ °C}$, $V_{bb} = 9...42\text{ V}$ unless otherwise specified	Symbol	Values			Unit
		min.	typ.	max.	

Operating Parameters

Operating voltage	$V_{bb(on)}$	4.9	-	60	V
Standby current Pin1 = open	$I_{bb(off)}$	-	2	10	μA

Protection Functions¹⁾

Initial peak short circuit current limit (see page 14) $T_j = -40\text{ °C}$, $V_{bb} = 13.5\text{ V}$, $t_m = 100\text{ }\mu\text{s}$ $T_j = 25\text{ °C}$ $T_j = 150\text{ °C}$	$I_{L(SCp)}$	-	-	1.2	A
		-	0.9	-	
		0.2	-	-	
Repetitive short circuit current limit $T_j = T_{jt}$	$I_{L(SCr)}$	-	0.7	-	
Output clamp (inductive load switch off) at $V_{OUT} = V_{bb} - V_{ON(CL)}$, $I_{bb} = 4\text{ mA}$	$V_{ON(CL)}$	60	-	-	V
Overvoltage protection $I_{bb} = 1\text{ mA}$	$V_{bbin(AZ)}$	62	68	-	
Thermal overload trip temperature	T_{jt}	150	-	-	
Thermal hysteresis	ΔT_{jt}	-	10	-	K

¹⁾ Integrated protection functions are designed to prevent IC destruction under fault conditions described in the data sheet. Fault conditions are considered as "outside" normal operating range. Protection functions are not designed for continuous repetitive operation.

Electrical Characteristics

Parameter at $T_j = -40...150\text{ }^\circ\text{C}$, $V_{bb} = 9...42\text{ V}$ unless otherwise specified	Symbol	Values			Unit
		min.	typ.	max.	
Input					
Off state input current $V_{OUT} \leq 0.1\text{ V}$ $T_j = 25\text{ }^\circ\text{C}$, $R_L = 270\ \Omega$ $T_j = 150\text{ }^\circ\text{C}$	$I_{IN(off)}$	-	-	0.05	mA
		-	-	0.04	
On state input current (Pin1 grounded) ¹⁾	$I_{IN(on)}$	-	0.3	1	
Input resistance	R_I	0.5	1	2.5	k Ω

Reverse Battery

Continuous reverse drain current $T_C = 25\text{ }^\circ\text{C}$	I_S	-	-	0.2	A
Drain-source diode voltage ($V_{OUT} > V_{bb}$) $I_F = 0.2\text{ A}$, $I_{IN} \leq 0,05\text{ mA}$	$-V_{ON}$	-	600	-	mV

¹⁾Driver circuit must be able to drive currents > 1mA.

EMC-Characteristics

All EMC-Characteristics are based on limited number of samples and no part of production test.

Test Conditions:

If not other specified the test circuitry is the minimal functional configuration without any external components for protection or filtering.

Supply voltage:	$V_{bb} = 13.5V$	Temperature:	$T_a = 23 \pm 5^\circ C$;
Load:	$R_L = 220\Omega$		
Operation mode:	PWM DC On/Off	Frequency:	100Hz / Duty Cycle: 50%
DUT-Specific.:	-		

Fast electrical transients

Acc. ISO 7637

Test Pulse	Test Level	Test Results		Pulse Cycle Time and Generator Impedance
		On	Off	
1	-200 V	C	C	500ms ; 10 Ω
2	+200 V	C	C	500ms ; 10 Ω
3a	-200 V	C	C	100ms ; 50 Ω
3b	+ 200 V	C	C	100ms ; 50 Ω
4 ¹⁾	-7 V	C	C	0,01 Ω
5	175 V	E (150V)	E (150V)	400ms ; 2 Ω

The test pulses are applied at V_{bb}

Definition of functional status

Class	Content
C	All functions of the device are performed as designed after exposure to disturbance.
E	One or more function of a device does not perform as designed after exposure and can not be returned to proper operation without repairing or replacing the device. The value after the character shows the limit.

Test circuit:

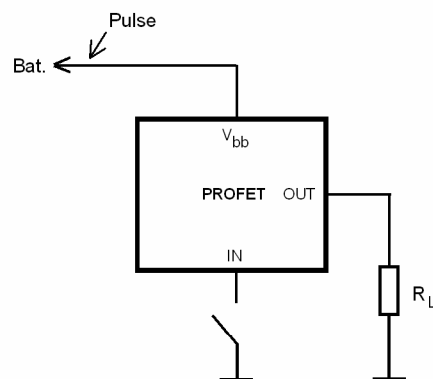

¹Supply voltage $V_{bb} = 12 V$ instead of 13.5 V.

Conducted Emission

Acc. IEC 61967-4 (1Ω / 150Ω method)

Typ. V_{bb} -Pin Emission at DC-On with 150Ω-matching network

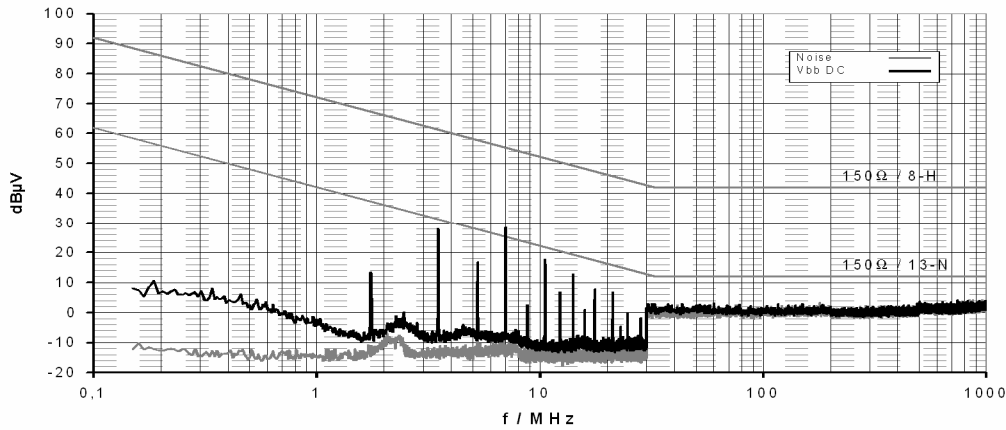

Typ. V_{bb} -Pin Emission at PWM-Mode with 150Ω-matching network

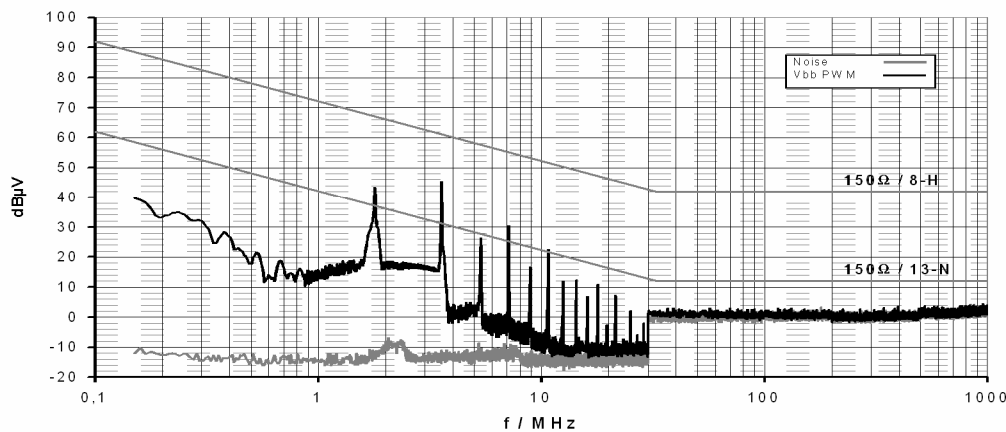

Test circuit:

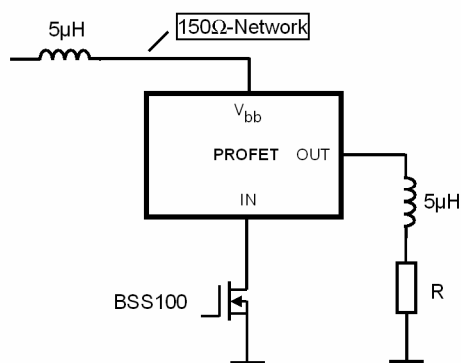

For defined decoupling and high reproducibility a defined choke (5μH at 1 MHz) is inserted between supply and V_{bb} -pin.

Conducted Susceptibility

Acc. 47A/658/CD IEC 62132-4 (Direct Power Injection)

Direct Power Injection: Forward Power CW
Failure criteria: Amplitude and frequency deviation max. 10% at Out

Typ. V_{bb} -Pin Susceptibility at DC-On/Off

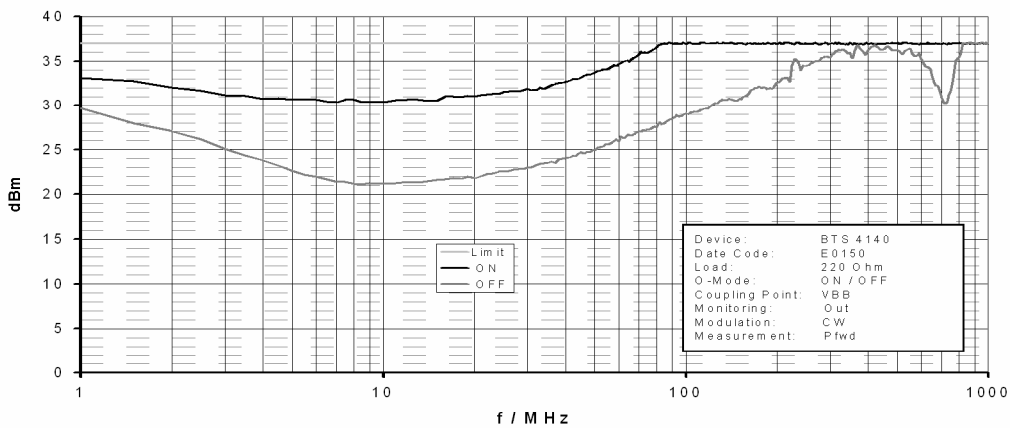

Typ. V_{bb} -Pin Susceptibility at PWM-Mode

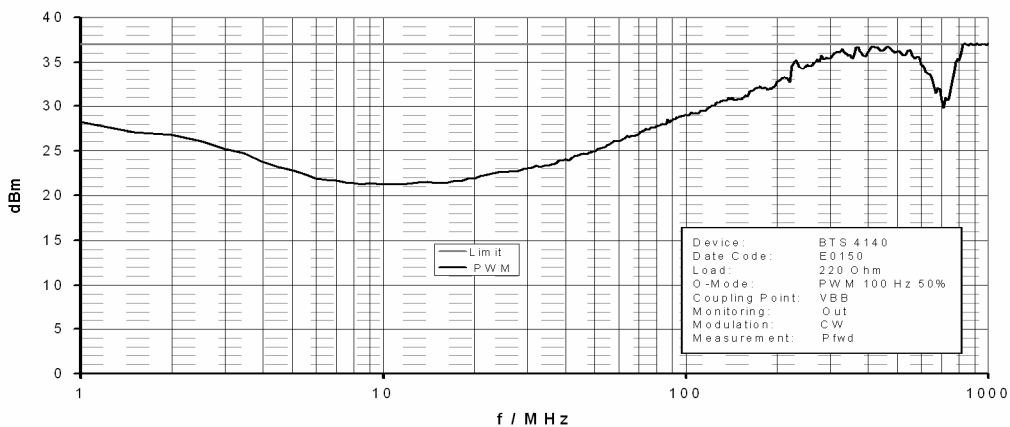

Test circuit:

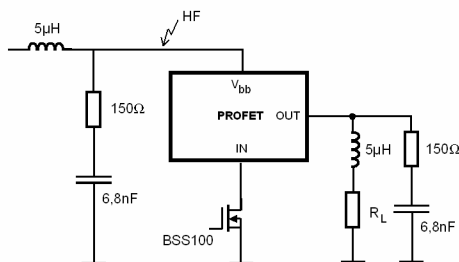

For defined decoupling and high reproducibility the same choke and the same 150Ω -matching network as for the emission measurement is used.

Terms

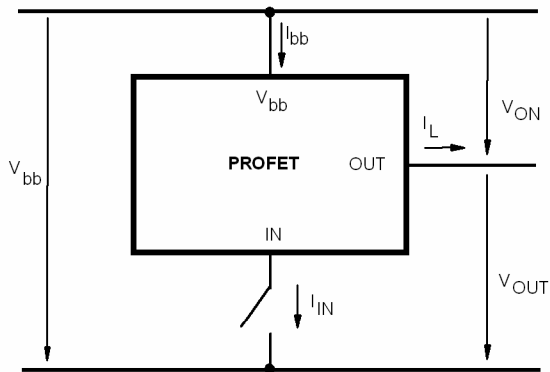

Inductive and overvoltage output clamp

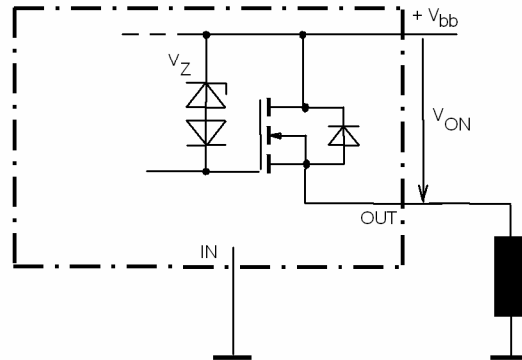

V_{ON} clamped to 60 V min.

Input circuit (ESD protection)

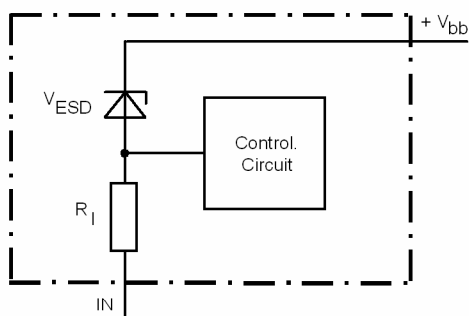

Overvoltage protection of logic part

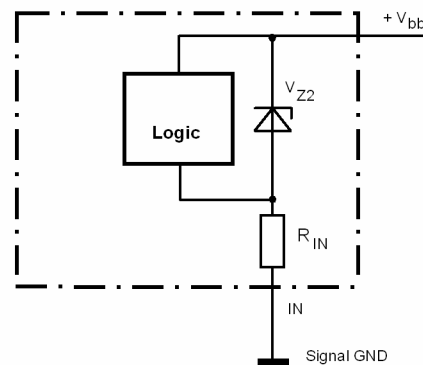

Reverse battery protection

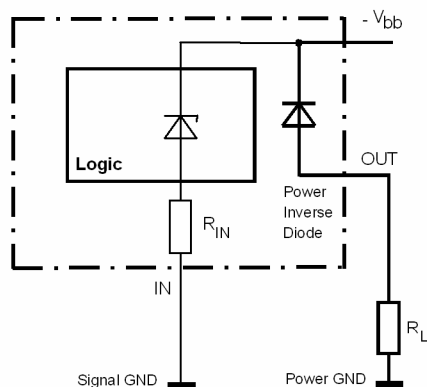

$$V_{bb,AZ} = V_{Z2} + I_{bb} * R_{IN} = 62V \text{ min.}$$

$R_I=1k\Omega$ typ., Temperature protection is not active during inverse current.

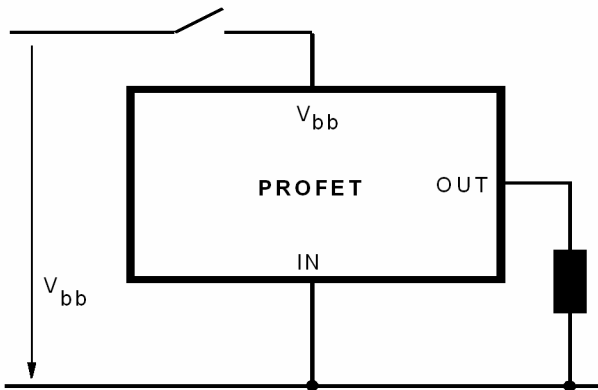
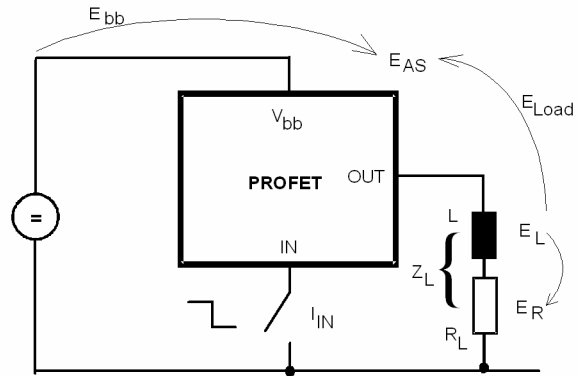
V_{bb} disconnect with charged inductive load

Inductive Load switch-off energy dissipation

Energy stored in load inductance: $E_L = \frac{1}{2} \cdot L \cdot I_L^2$

While demagnetizing load inductance, the energy dissipated in PROFET is

$E_{AS} = E_{bb} + E_L - E_R = V_{ON(CL)} \cdot \int i_L(t) dt$,
with an approximate solution for $R_L > 0\Omega$:

$$E_{AS} = \frac{L}{R_L} \cdot (V_{bb} + |V_{OUT(CL)}|) \cdot \left[\frac{-|V_{OUT(CL)}|}{R_L} \cdot \ln \left(1 + \frac{R_L \cdot I_L}{|V_{OUT(CL)}|} \right) + I_L \right]$$

Typ. transient thermal impedance

$Z_{thJA} = f(t_p)$ @ 6cm² heatsink area

Parameter: $D = t_p / T$

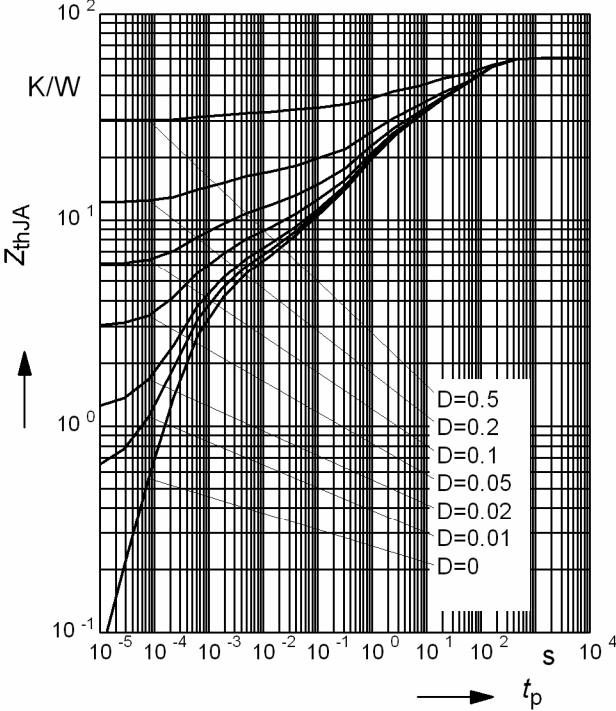

Typ. transient thermal impedance

$Z_{thJA} = f(t_p)$ @ min. footprint

Parameter: $D = t_p / T$

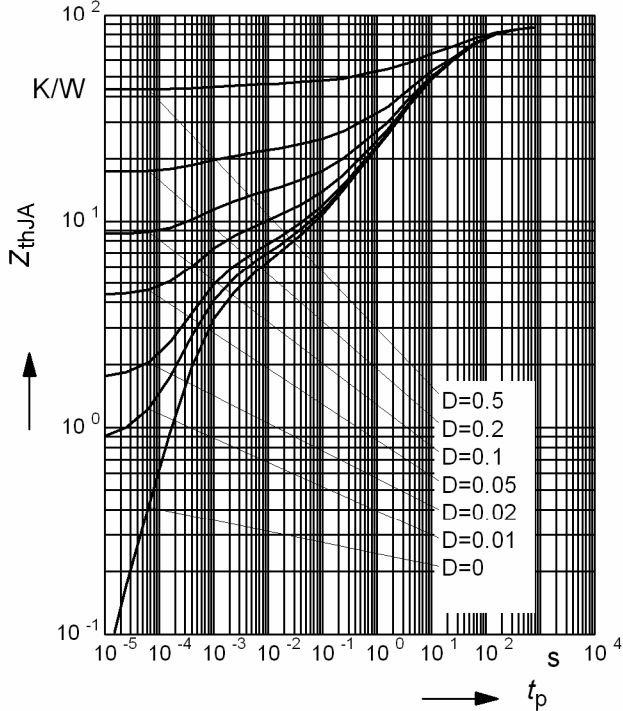

Typ. on-state resistance

$R_{ON} = f(T_j)$; $V_{bb} = 9V$; Pin1 grounded;
 $I_L = 150mA$

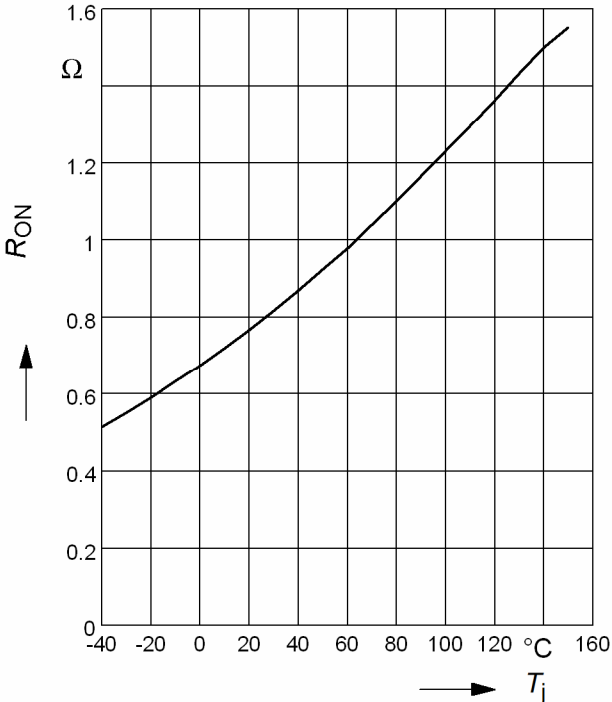

Typ. on-state resistance

$R_{ON} = f(V_{bb})$; $I_L = 150mA$; Pin1 grounded

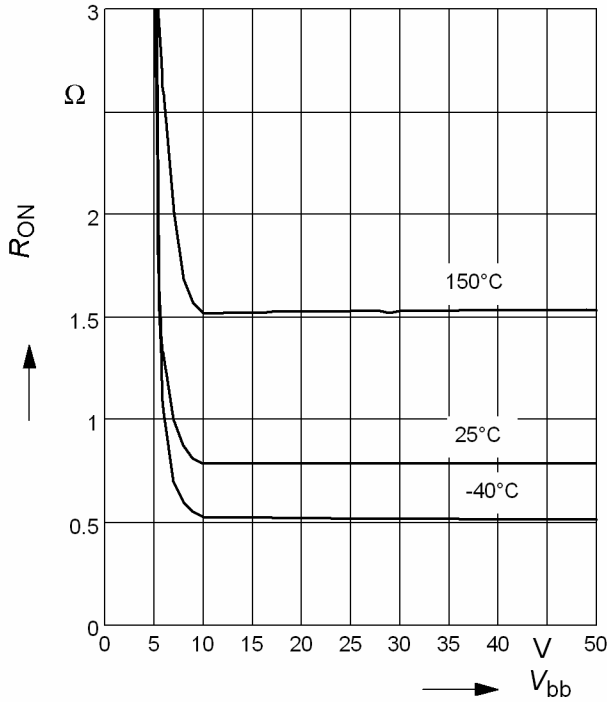

Typ. turn on time

$$t_{on} = f(T_j); R_L = 270\Omega$$

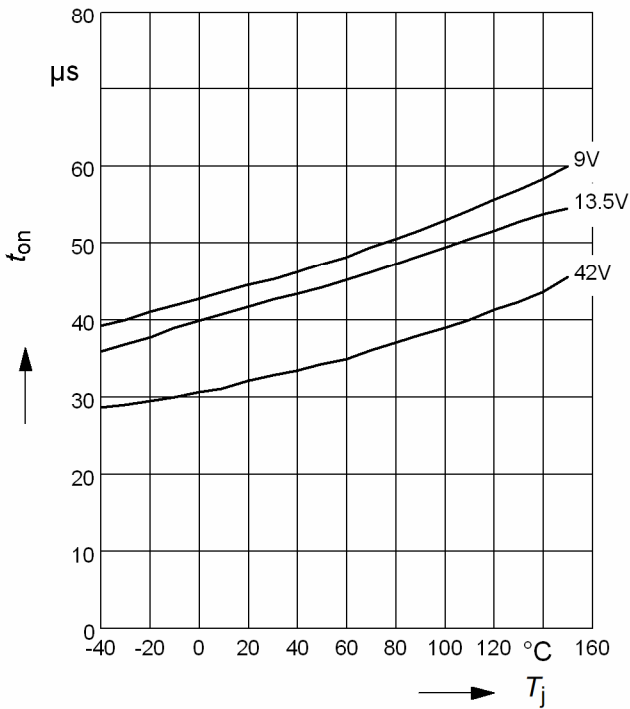
Typ. turn off time

$$t_{off} = f(T_j); R_L = 270\Omega$$

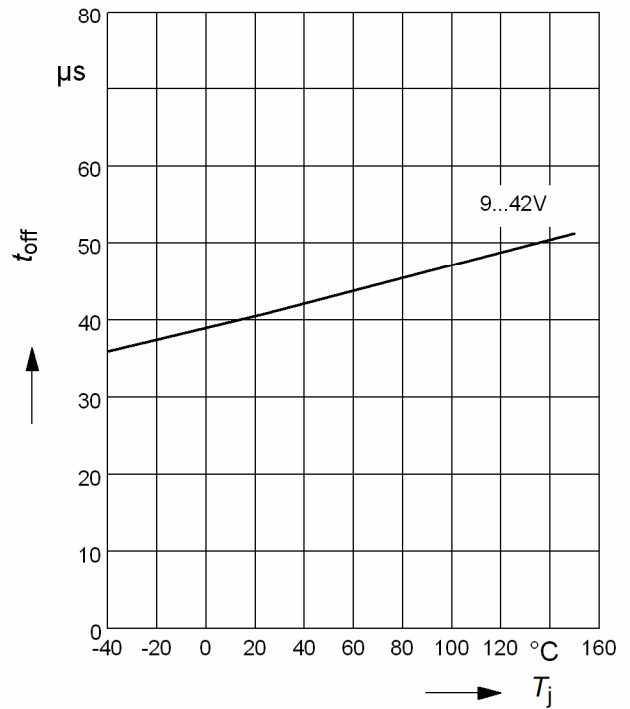
Typ. slew rate on

$$dV/dt_{on} = f(T_j); R_L = 270\Omega$$

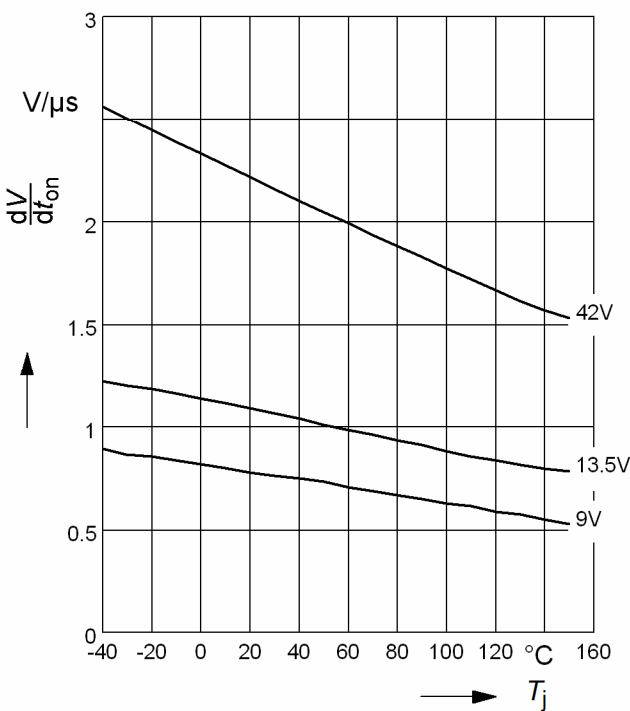

Typ. slew rate off

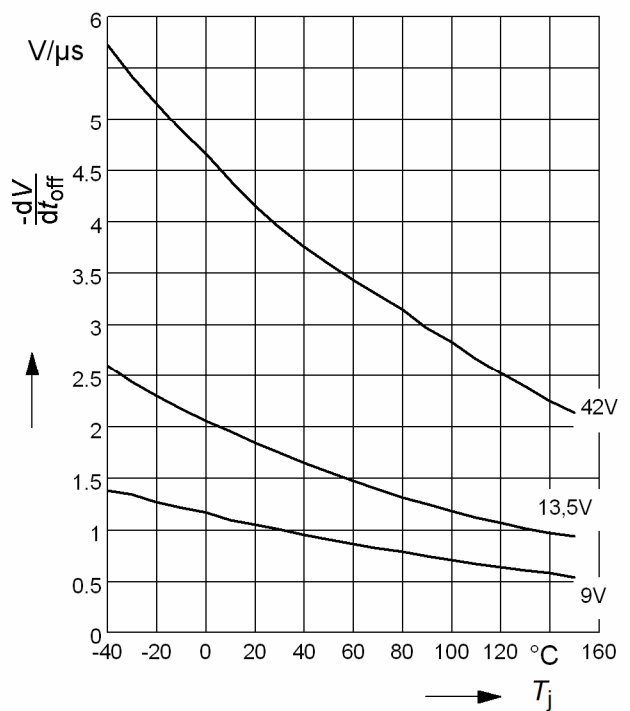
$$-dV/dt_{off} = f(T_j); R_L = 270\Omega$$

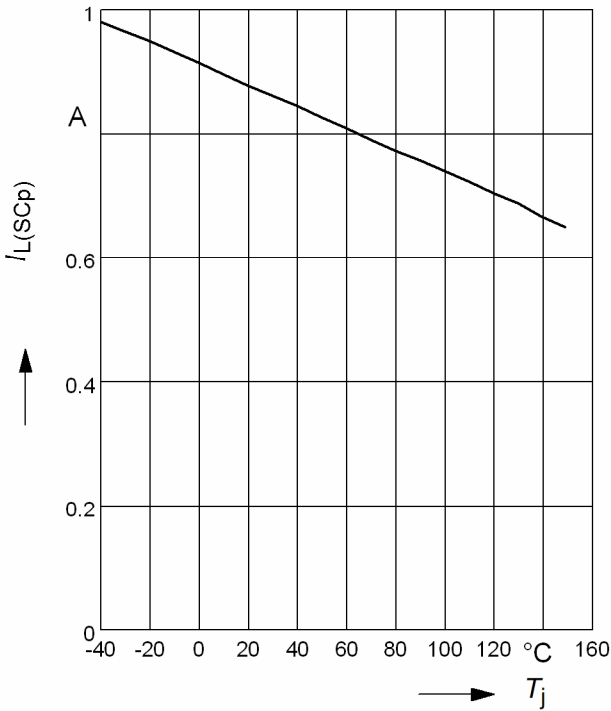

Typ. initial peak short circuit current limit

$$I_{L(SCp)} = f(T_j) ; V_{bb} = 13,5 \text{ V}; t_m = 100 \mu\text{s}$$



Typ. initial short circuit shutdown time

$$t_{off(SC)} = f(T_{j,start})$$

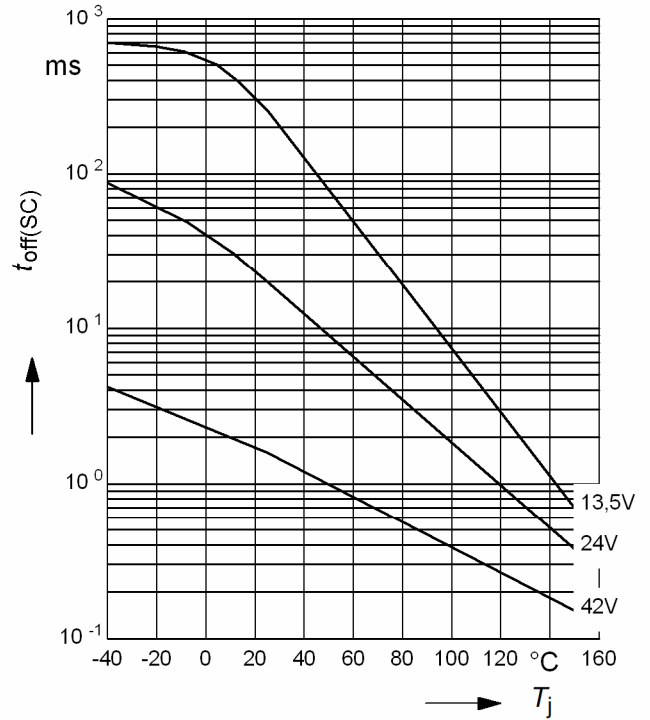

Typ. initial peak short circuit current limit

$$I_{L(SCp)} = f(V_{bb}); t_m = 100 \mu\text{s}$$

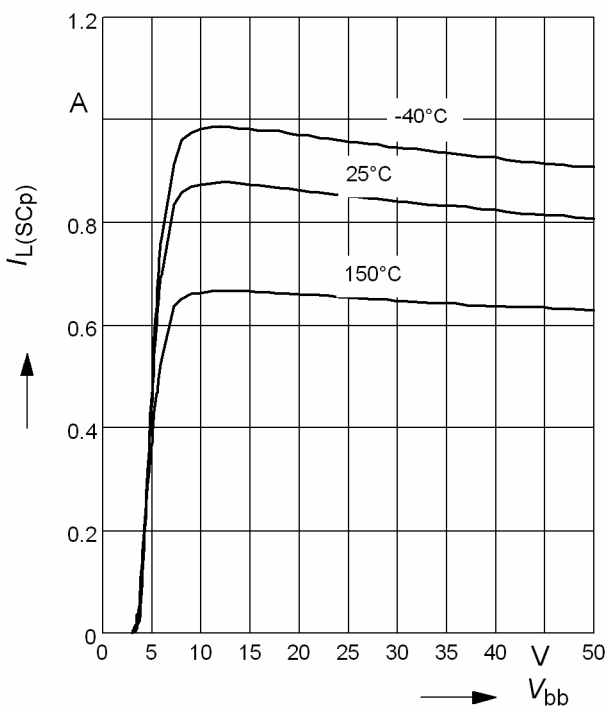

Typ. current limitation characteristic:

$$I_{L(SC)} = f(V_{ON}), V_{bb} = 13,5\text{V}$$

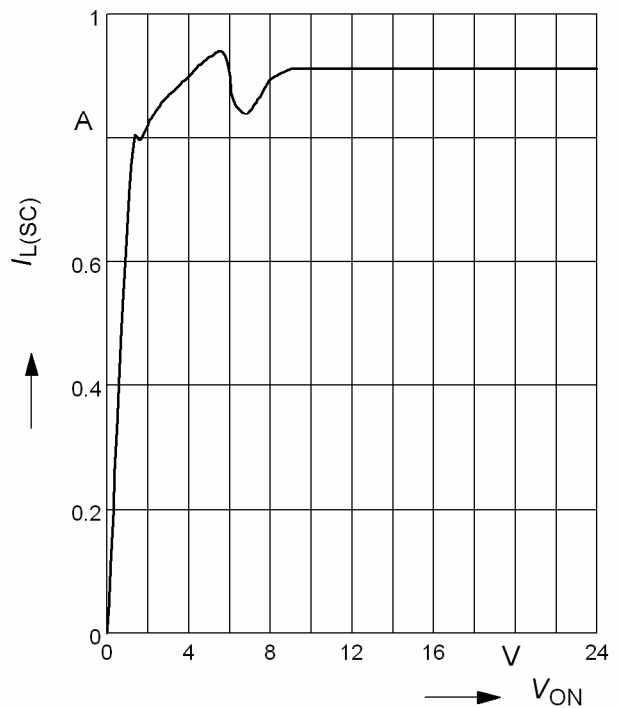

Typ. standby current

$I_{bb(off)} = f(T_j)$; Pin1 open

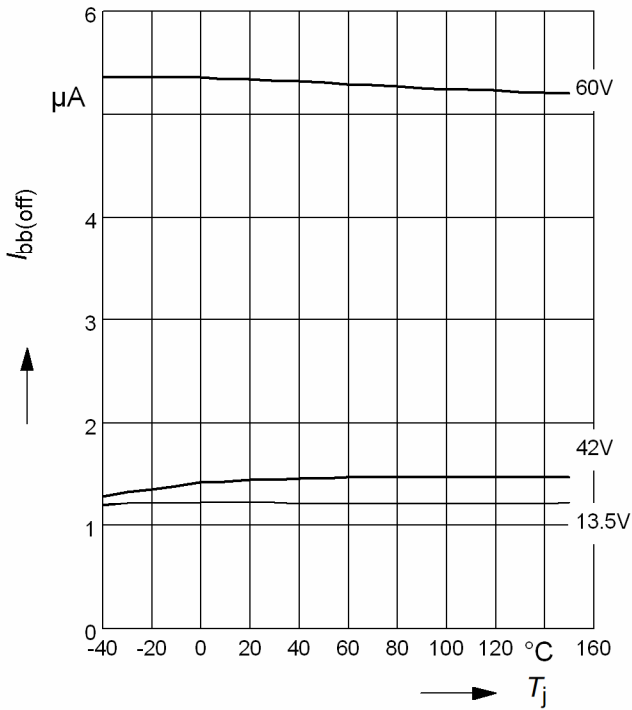

Maximum allowable inductive switch-off energy, single pulse

$E_{AS} = f(I_L)$; $T_{jstart} = 150^{\circ}C$

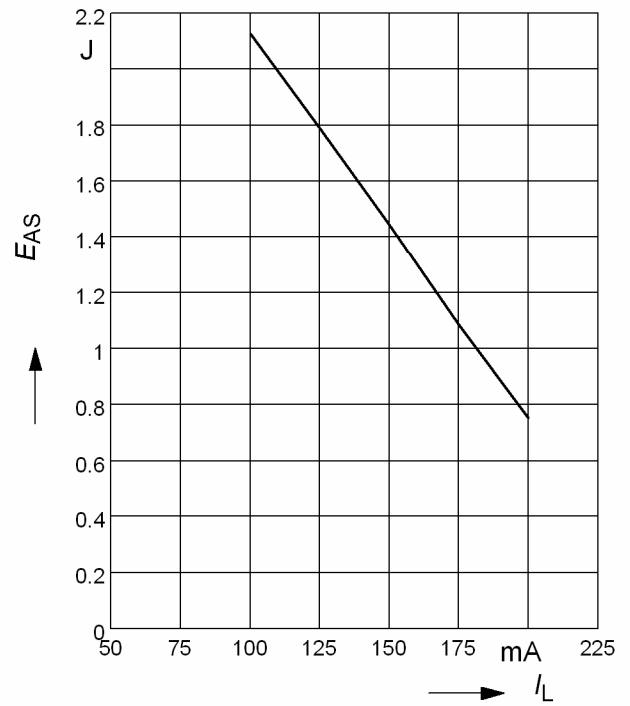

Timing diagrams

Figure 1a: V_{bb} turn on:

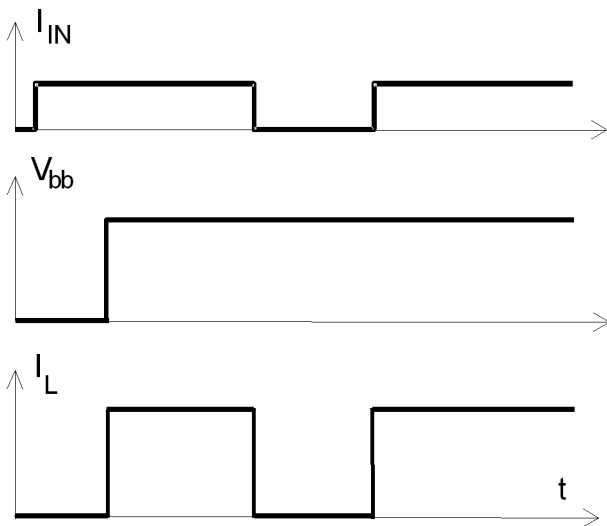

Figure 2b: Switching a lamp

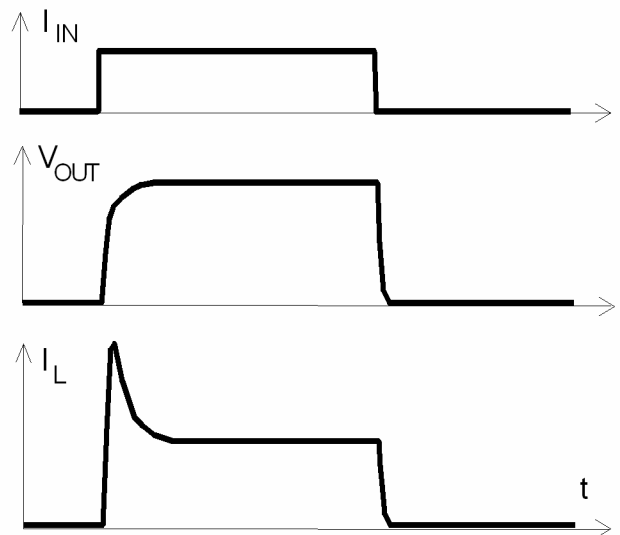

Figure 2a: Switching a resistive load, turn-on/off time and slew rate definition

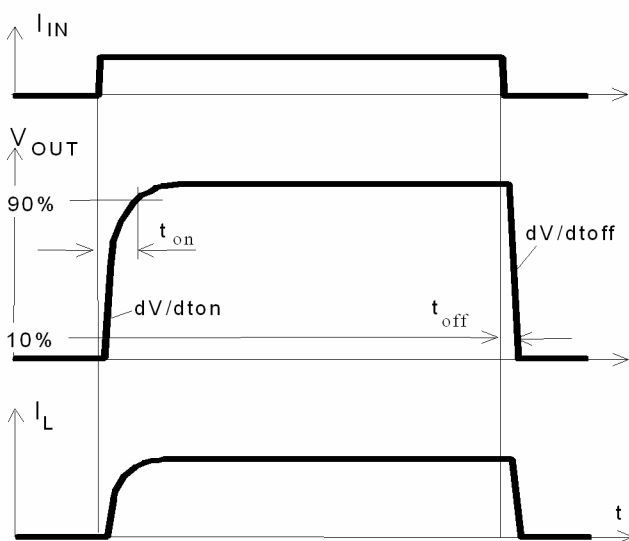

Figure 2c: Switching an inductive load

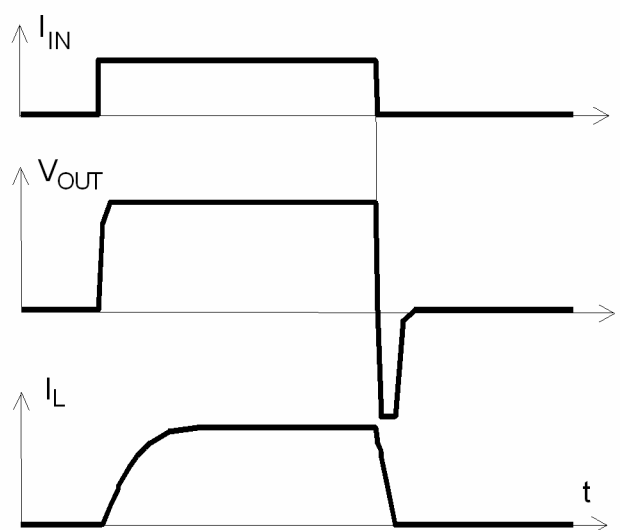
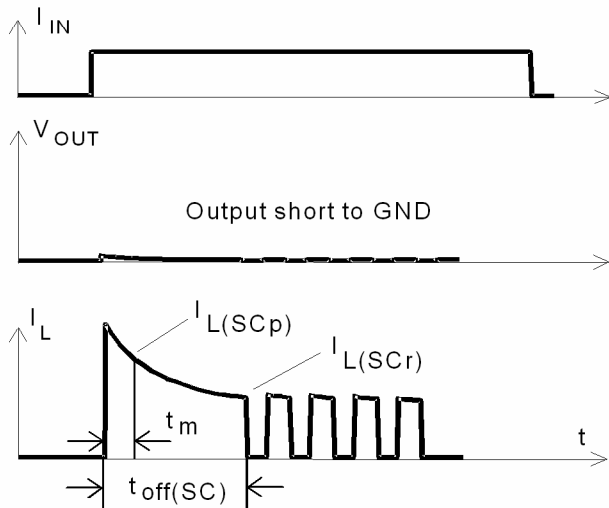

Figure 3a: Turn on into short circuit, shut down by overtemperature, restart by cooling



Heating up of the chip may require several milliseconds, depending on external conditions.

Figure 3b: Short circuit in on-state shut down by overtemperature, restart by cooling

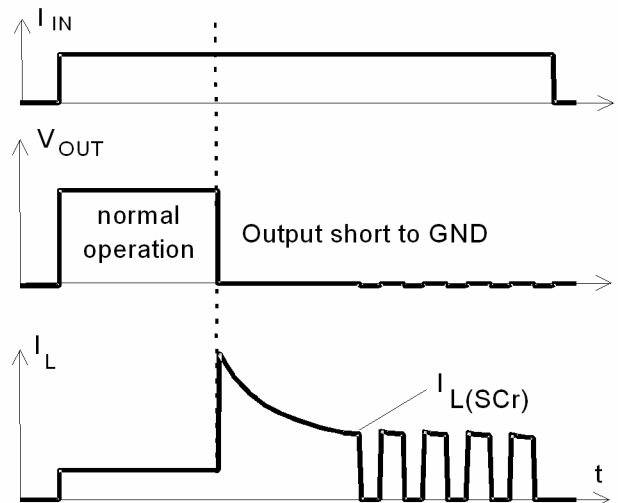
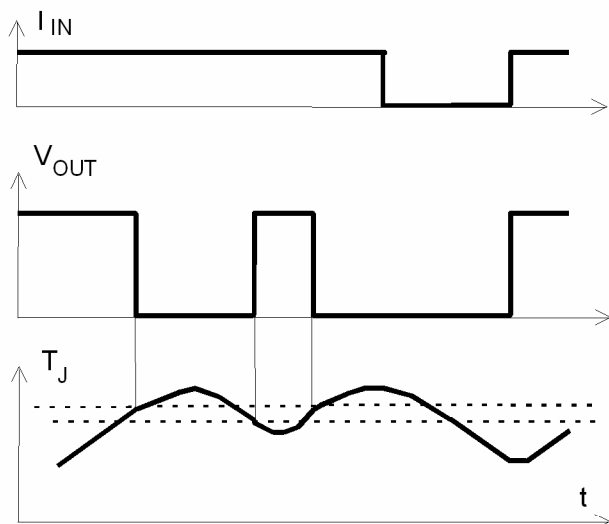

Figure 4: Overtemperature: Reset if $T_j < T_{jt}$





Компания «ЭлектроПласт» предлагает заключение долгосрочных отношений при поставках импортных электронных компонентов на взаимовыгодных условиях!

Наши преимущества:

- Оперативные поставки широкого спектра электронных компонентов отечественного и импортного производства напрямую от производителей и с крупнейших мировых складов;
- Поставка более 17-ти миллионов наименований электронных компонентов;
- Поставка сложных, дефицитных, либо снятых с производства позиций;
- Оперативные сроки поставки под заказ (от 5 рабочих дней);
- Экспресс доставка в любую точку России;
- Техническая поддержка проекта, помощь в подборе аналогов, поставка прототипов;
- Система менеджмента качества сертифицирована по Международному стандарту ISO 9001;
- Лицензия ФСБ на осуществление работ с использованием сведений, составляющих государственную тайну;
- Поставка специализированных компонентов (Xilinx, Altera, Analog Devices, Intersil, Interpoint, Microsemi, Aeroflex, Peregrine, Syfer, Eurofarad, Texas Instrument, Miteq, Cobham, E2V, MA-COM, Hittite, Mini-Circuits, General Dynamics и др.);

Помимо этого, одним из направлений компании «ЭлектроПласт» является направление «Источники питания». Мы предлагаем Вам помощь Конструкторского отдела:

- Подбор оптимального решения, техническое обоснование при выборе компонента;
- Подбор аналогов;
- Консультации по применению компонента;
- Поставка образцов и прототипов;
- Техническая поддержка проекта;
- Защита от снятия компонента с производства.



Как с нами связаться

Телефон: 8 (812) 309 58 32 (многоканальный)

Факс: 8 (812) 320-02-42

Электронная почта: org@eplast1.ru

Адрес: 198099, г. Санкт-Петербург, ул. Калинина, дом 2, корпус 4, литера А.