



# LV8716QA

Bi-CDMOS LSI

## Dual H-bridge Motor Driver

ON Semiconductor®

<http://onsemi.com>

### Overview

LV8716QA is 2ch H-bridge driver in the forward/reverse/brake/standby 4 mode corresponding to a low voltage drive. It is the best for the stepper motors for a battery drive, such as a mobile printer and DC motors.

### Function

- 2-channel PWM current control H-bridge driver
- BiCDMOS process IC
- Low ON resistance (Upper side : 0.65Ω, Lower side 0.35Ω : Ta=25°C, Io=1.0A)
- 4 mode of forward/reverse/brake/standby
- Available constant current control less RF resistance
- Built-in UVLO, TSD circuit

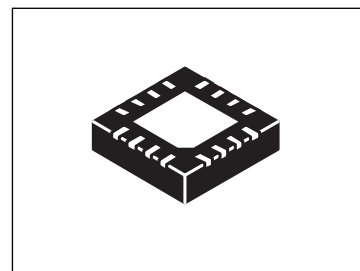

QFN16 3x3, 0.5P

### Specifications

**Absolute Maximum Ratings** at Ta = 25°C

Parameter	Symbol	Conditions	Ratings	Unit
Motor supply voltage	VMmax	VM1, VM2	12.6	V
Output peak current	Iopeak	Tw ≤ 10ms, duty 20%	1.5	A
Output current	Iomax		1.0	A
Logic input voltage	VINmax	PS, IN1, IN2, IN3, IN4	-0.3 to +6	V
Allowable power dissipation	Pd max	*	1.55	W
Operating temperature	Topr		-20 to +85	°C
Storage temperature	Tstg		-55 to +150	°C

\*Specified circuit board : 57mm×57mm×1.6mm, glass epoxy 2-layer board, with backside mounting.

Caution 1) Absolute maximum ratings represent the values which cannot be exceeded for any length of time.

Caution 2) Even when the device is used within the range of absolute maximum ratings, as a result of continuous usage under high temperature, high current, high voltage, or drastic temperature change, the reliability of the IC may be degraded. Please contact us for the further details.

Stresses exceeding those listed in the Maximum Ratings table may damage the device. If any of these limits are exceeded, device functionality should not be assumed, damage may occur and reliability may be affected.

### ORDERING INFORMATION

See detailed ordering and shipping information on page 15 of this data sheet.

## LV8716QA

### Recommended Operating Conditions at $T_a = 25^\circ\text{C}$

Parameter	Symbol	Conditions	Ratings	Unit
Motor supply voltage range	VM	VM1,VM2	2.7 to 10.5	V
Logic input voltage	VIN	PS,IN1,IN2,IN3,IN4	0 to 5.5	V

Functional operation above the stresses listed in the Recommended Operating Ranges is not implied. Extended exposure to stresses beyond the Recommended Operating Ranges limits may affect device reliability.

### Electrical Characteristics at $T_a = 25^\circ\text{C}$ , $V_M = 7.2\text{V}$

Parameter	Symbol	Conditions	Ratings			Unit
			min	typ	max	
Standby mode current	IMstn	PS="L", I(VM1)+I(VM2)		0	500	nA
Supply Current	IM	PS="H", IN1=IN3="H", No load I(VM1)+I(VM2)		1.4	1.82	mA
VM low voltage cutting threshold voltage	Vthvm		2.3	2.45	2.6	V
Low voltage hysteresis voltage	Vthhis		100	200	300	mV
Thermal shutdown temperature	TSD	Design guarantee	150	180	200	$^\circ\text{C}$
Thermal hysteresis width	$\Delta\text{TSD}$	Design guarantee		40		$^\circ\text{C}$
Output on resistance	Ronu	Io=1A,Source-side		0.65	0.85	$\Omega$
	Rond	Io=1A,Sink-side		0.35	0.45	$\Omega$
Output leakage current	Ioleak				20	$\mu\text{A}$
Diode forward voltage	VD	ID=-1A		1	1.2	V
Logic high-level input voltage	Vinh	PS,IN1,IN2,IN3,IN4	2.0		5.5	V
Logic low-level input voltage	Vinl		0		0.8	V
PS pin input current	IinL	VIN=0.8V	5	8	11	$\mu\text{A}$
	IinH	VIN=3.3V	35	50	65	$\mu\text{A}$
Logic pin input current (IN1,IN2,IN3,IN4)	IinL	VIN=0.8V	5	8	11	$\mu\text{A}$
	IinH	VIN=3.3V	23	33	43	$\mu\text{A}$
Chopping cycle	Tchop		12	16	20	$\mu\text{s}$
Current detection reference voltage	Vref		0.194	0.2	0.206	V
Output current detection current	Ircs	Io=0.5A, RCS=0V	115	125	135	$\mu\text{A}$

Product parametric performance is indicated in the Electrical Characteristics for the listed test conditions, unless otherwise noted. Product performance may not be indicated by the Electrical Characteristics if operated under different conditions.

# LV8716QA

## Package Dimensions

unit : mm

QFN16 3x3, 0.5P

CASE 485G-01

ISSUE F

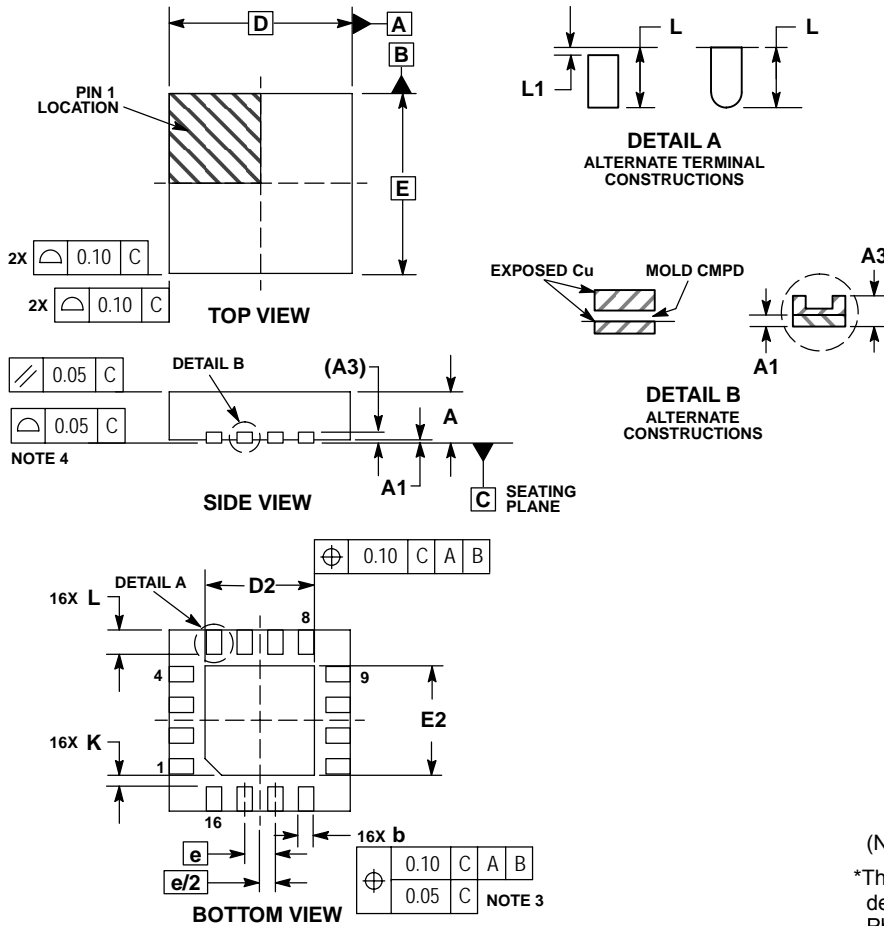

**NOTES:**

1. DIMENSIONING AND TOLERANCING PER ASME Y14.5M, 1994.
2. CONTROLLING DIMENSION: MILLIMETERS.
3. DIMENSION b APPLIES TO PLATED TERMINAL AND IS MEASURED BETWEEN 0.25 AND 0.30 MM FROM TERMINAL.
4. COPLANARITY APPLIES TO THE EXPOSED PAD AS WELL AS THE TERMINALS.

MILLIMETERS			
DIM	MIN	NOM	MAX
A	0.80	0.90	1.00
A1	0.00	0.03	0.05
A3	0.20 REF		
b	0.18	0.24	0.30
D	3.00 BSC		
D2	1.65	1.75	1.85
E	3.00 BSC		
E2	1.65	1.75	1.85
e	0.50 BSC		
k	0.18 TYP		
L	0.30	0.40	0.50
L1	0.00	0.08	0.15

**GENERIC MARKING DIAGRAM\***

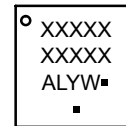

- XXXXX = Specific Device Code
- A = Assembly Location
- L = Wafer Lot
- Y = Year
- W = Work Week
- = Pb-Free Package

(Note: Microdot may be in either location)

\*This information is generic. Please refer to device data sheet for actual part marking. Pb-Free indicator, "G" or microdot "■", may or may not be present.

**RECOMMENDED SOLDERING FOOTPRINT\***

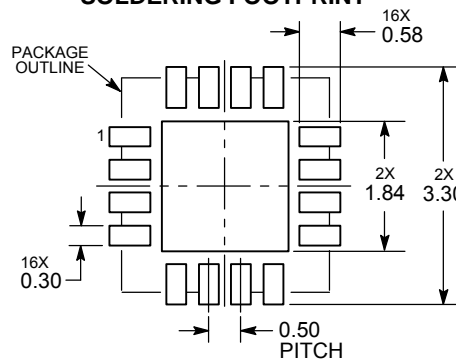

DIMENSIONS: MILLIMETERS

\*For additional information on our Pb-Free strategy and soldering details, please download the ON Semiconductor Soldering and Mounting Techniques Reference Manual, SOLDERRM/D.

# LV8716QA

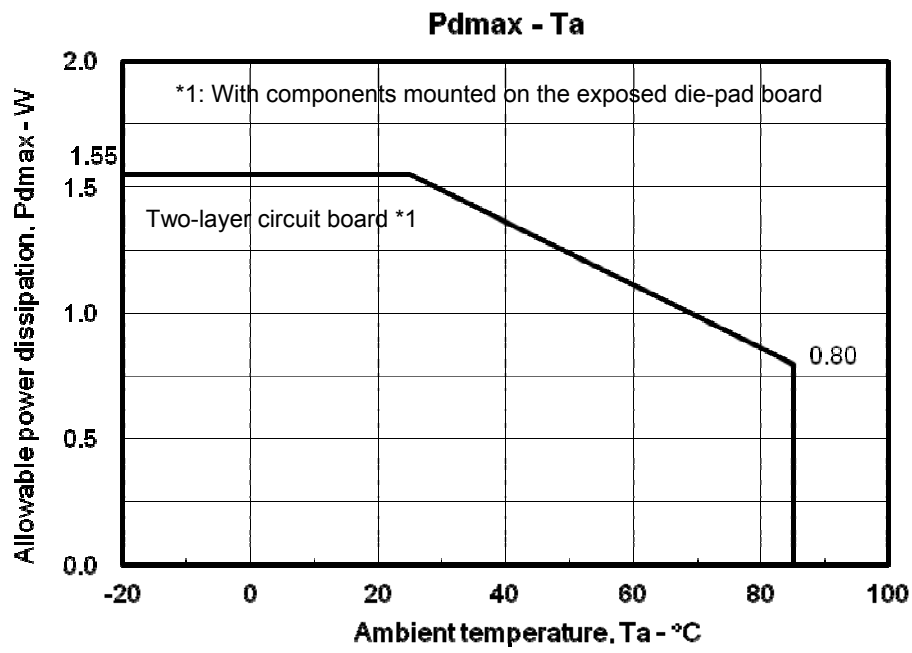

## LV8716QA

### Substrate Specifications (Substrate recommended for operation of LV8716QA)

Size	: 90mm × 90mm × 1.6mm (two-layer substrate )
Material	: Glass epoxy
Copper wiring density	: L1 = 85%, L2 = 90%

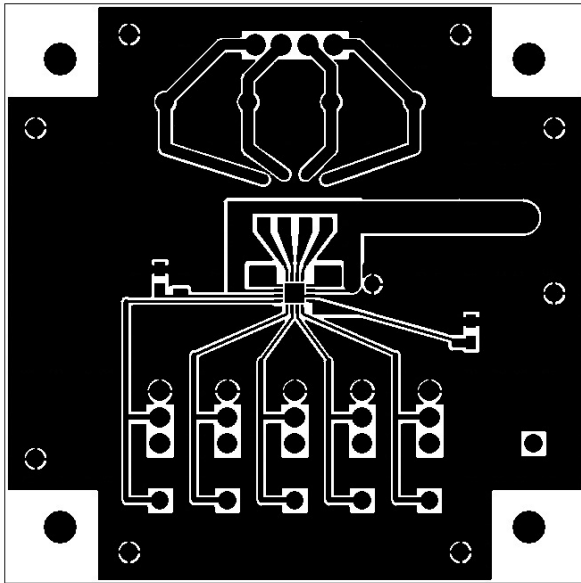

L1: Copper wiring pattern diagram

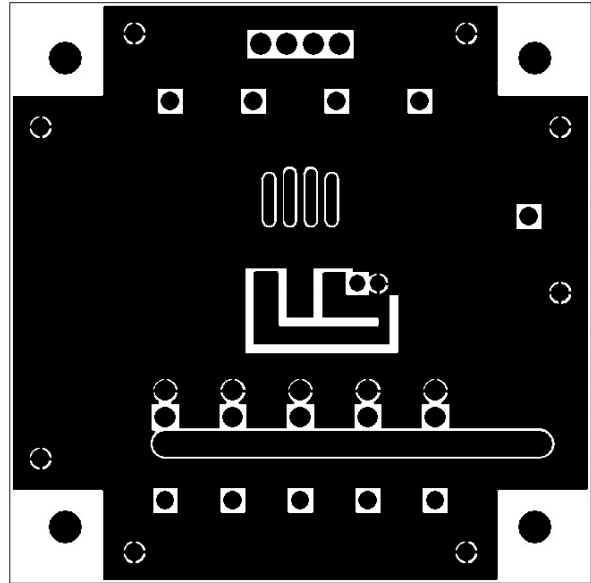

L2: Copper wiring pattern diagram

### Cautions

- 1) The data for the case with the Exposed Die-Pad substrate mounted shows the values when 90% or more of the Exposed Die-Pad is wet.
- 2) For the set design, employ the derating design with sufficient margin.  
Stresses to be derated include the voltage, current, junction temperature, power loss, and mechanical stresses such as vibration, impact, and tension.  
Accordingly, the design must ensure these stresses to be as low or small as possible.  
The guideline for ordinary derating is shown below:
  - (1) Maximum value 80% or less for the voltage rating
  - (2) Maximum value 80% or less for the current rating
  - (3) Maximum value 80% or less for the temperature rating
- 3) After the set design, be sure to verify the design with the actual product.  
Confirm the solder joint state and verify also the reliability of solder joint for the Exposed Die-Pad, etc.  
Any void or deterioration, if observed in the solder joint of these parts, causes deteriorated thermal conduction, possibly resulting in thermal destruction of IC.

# LV8716QA

## Pin Assignment

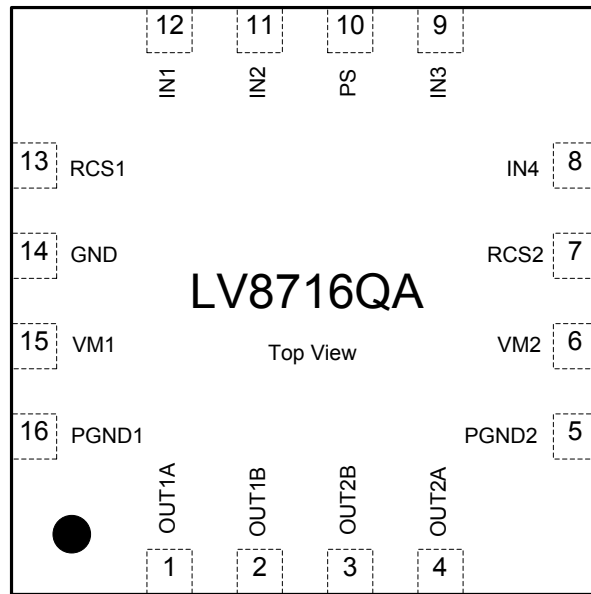

## Block Diagram

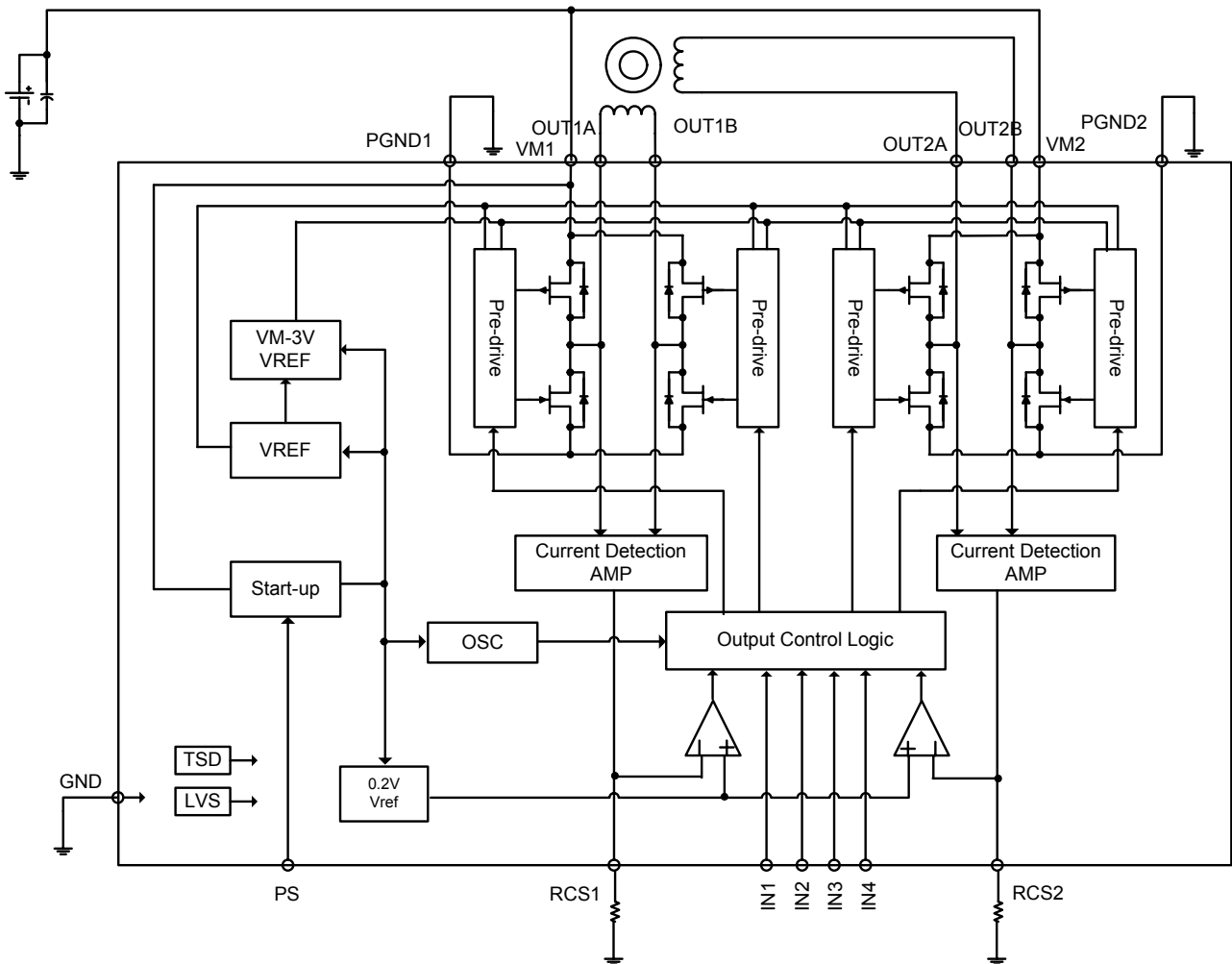

# LV8716QA

## Pin Functions

Pin No.	Pin Name	Pin Function
15	VM1	1ch Motor power supply pin.
6	VM2	2ch Motor power supply pin.
10	PS	Power save signal input pin.
12	IN1	1ch control signal input pin.
11	IN2	
9	IN3	
8	IN4	
13	RCS1	1ch output current detecting resistor connection pin.
7	RCS2	2ch output current detecting resistor connection pin.
14	GND	GND
16	PGND1	1ch power GND.
1	OUT1A	1ch OUTA output pin.
2	OUT1B	1ch OUTB output pin.
3	OUT2B	2ch OUTB output pin.
4	OUT2A	2ch OUTA output pin.
5	PGND2	2ch power GND.

## Equivalent Circuit

Pin No.	Pin Name	Equivalent Circuit
10	PS	
12 11 9 8	IN1 IN2 IN3 IN4	

Continued on next page

# LV8716QA

Continued from preceding page.

Pin No.	Pin Name	Equivalent Circuit
15 16 1 2 6 5 4 3	VM1 PGND1 OUT1A OUT1B VM2 PGND2 OUT2A OUT2B	
13 7	RCS1 RCS2	



**Description of operation**

**1. Input pin function**

The function to prevent that the current flows into a power supply from the each input pin is built in. Therefore, current does not flow into power supply from the input pin when power supply is OFF.

**2. Chip enables function**

Standby mode/operating mode of the IC are switched by setting the PS pin. In the standby-state, the IC enters a power saving mode and all logic is reset. In the standby-state, internal regulator circuit is not operative.

PS	Condition	Internal regulator
“L” or OPEN	Standby mode	Standby
“H”	Operating mode	Operation

**3. Output control signal logic**

**DC motor**

Input signal				Output				Mode
IN1	IN2	IN3	IN4	OUT1A	OUT1B	OUT2A	OUT2B	
L	L	-	-	OFF	OFF	-	-	Standby
H	L	-	-	H	L	-	-	CW (Forward)
L	H	-	-	L	H	-	-	CCW (Reverse)
H	H	-	-	L	L	-	-	Brake
-	-	L	L	-	-	OFF	OFF	Standby
-	-	H	L	-	-	H	L	CW (Forward)
-	-	L	H	-	-	L	H	CCW (Reverse)
-	-	H	H	-	-	L	L	Brake

**Stepper motor**

Input signal				Output				Function	
IN1	IN2	IN3	IN4	OUT1A	OUT1B	OUT2A	OUT2B	Full step	Half step
L	L	L	L	Off	Off	Off	Off	Standby	Standby
H	L	H	L	High	Low	High	Low	Step 1	Step 1
L	L	H	L	Off	Off	High	Low	-	Step 2
L	H	H	L	Low	High	High	Low	Step 2	Step 3
L	H	L	L	Low	High	Off	Off	-	Step 4
L	H	L	H	Low	High	Low	High	Step 3	Step 5
L	L	L	H	Off	Off	Low	High	-	Step 6
H	L	L	H	High	Low	Low	High	Step 4	Step 7
H	L	L	L	High	Low	Off	Off	-	Step 8

4. Typical current waveform in each excitation mode.

Full step (CW mode)

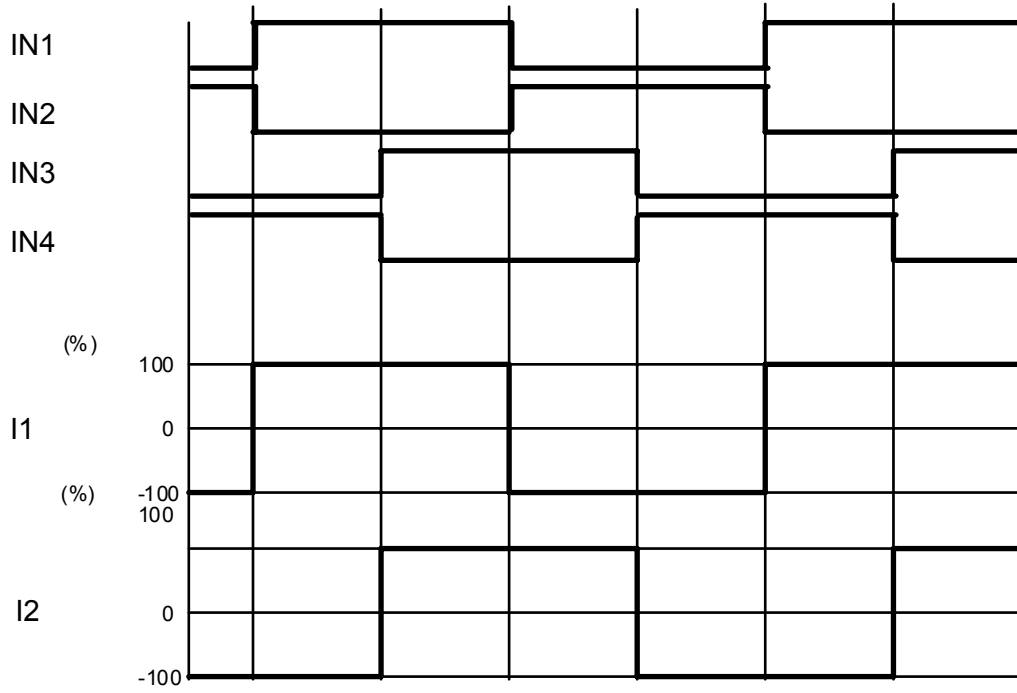

Half step full torque (CW mode)

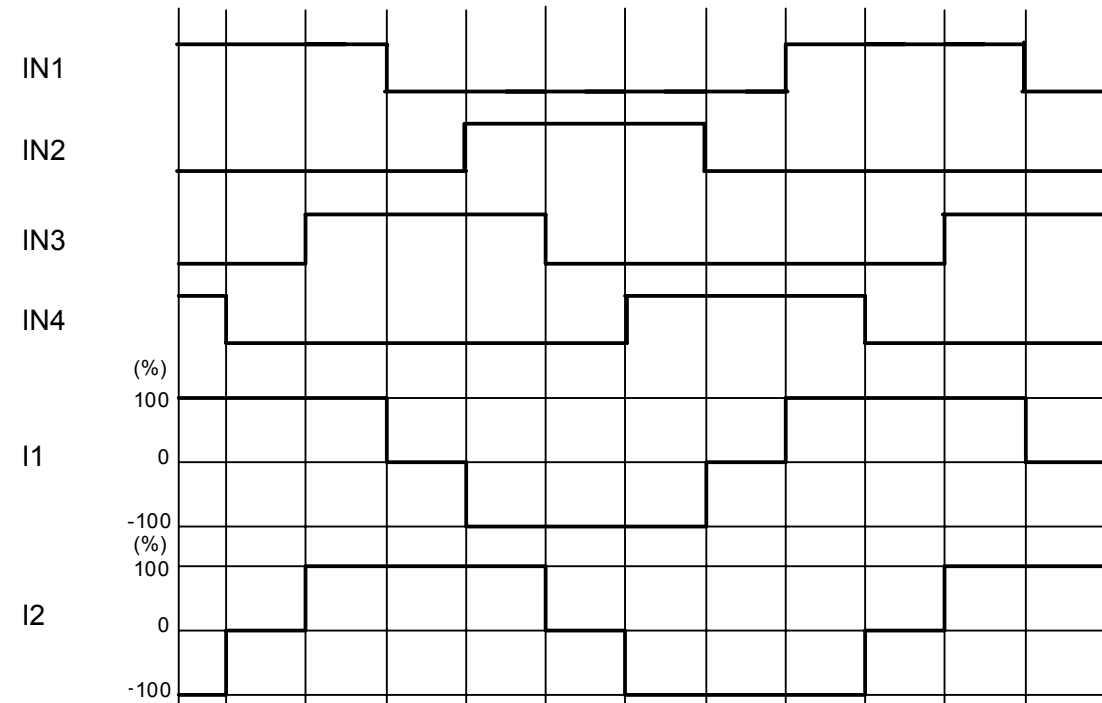

5. PWM constant-current control

LV8716QA performs constant current control of coil current by PWM chopping of the output pin, as opposed to the output detection current set up by connecting external resistance to RCS pin.

(Constant-current control time chart)

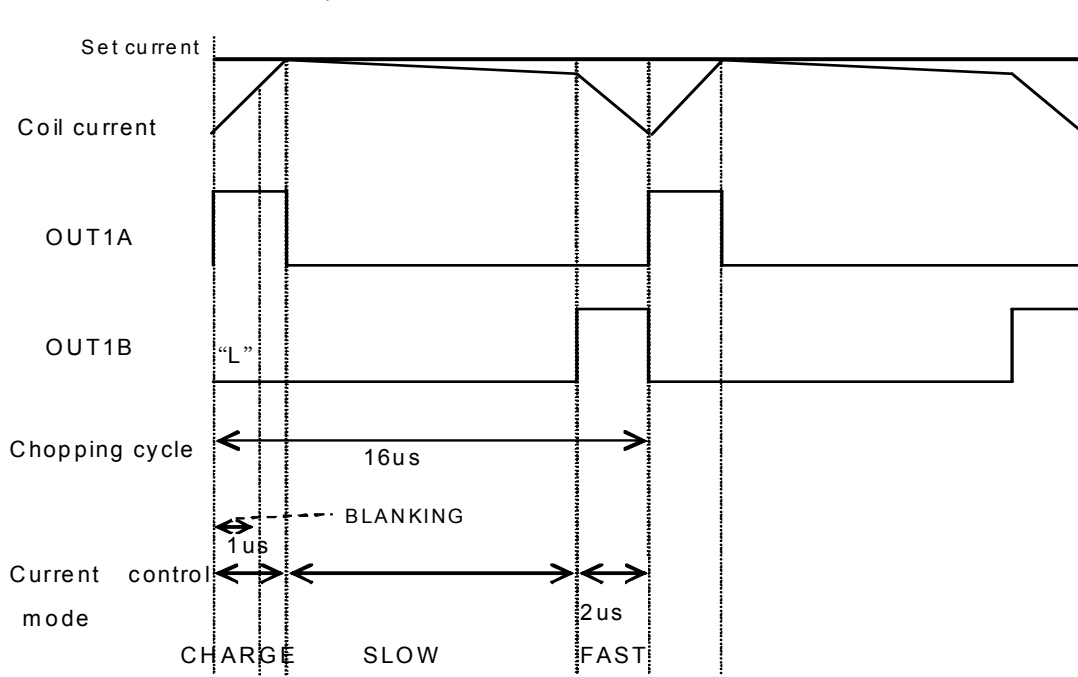

Detection current setting method

For setting the output current are as follows:

IC internal reference voltage ( $V_{ref} = 0.2V$ ), between RCS pin and GND pin connecting resistance is RCS.

$$I_{out} = 0.2V/RCS \times 4000$$

e.g.  $RCS = 2k\Omega$

$$I_{out} = 0.2V/2k\Omega \times 4000 = 0.4A$$

# LV8716QA

## 6. Application Circuit Example

### 6-1) Stepper motor driver circuit

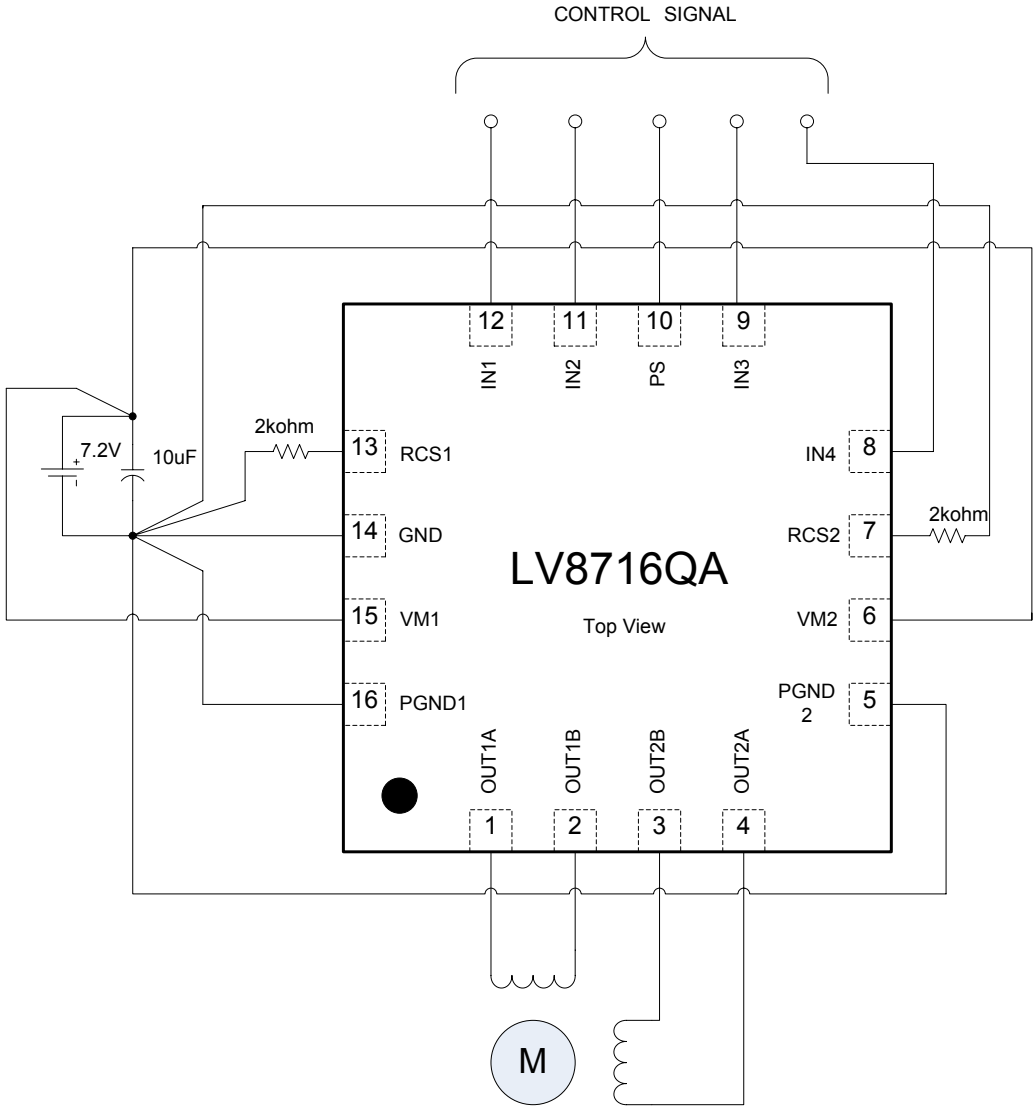

The formulae for setting the PWM constant current above is as follows :

$$I_{out} = 0.2 / 2k\Omega \times 4000 = 400mA \quad (RCS=2k\Omega)$$

## LV8716QA

### 6-2) High current DC motor driver circuit

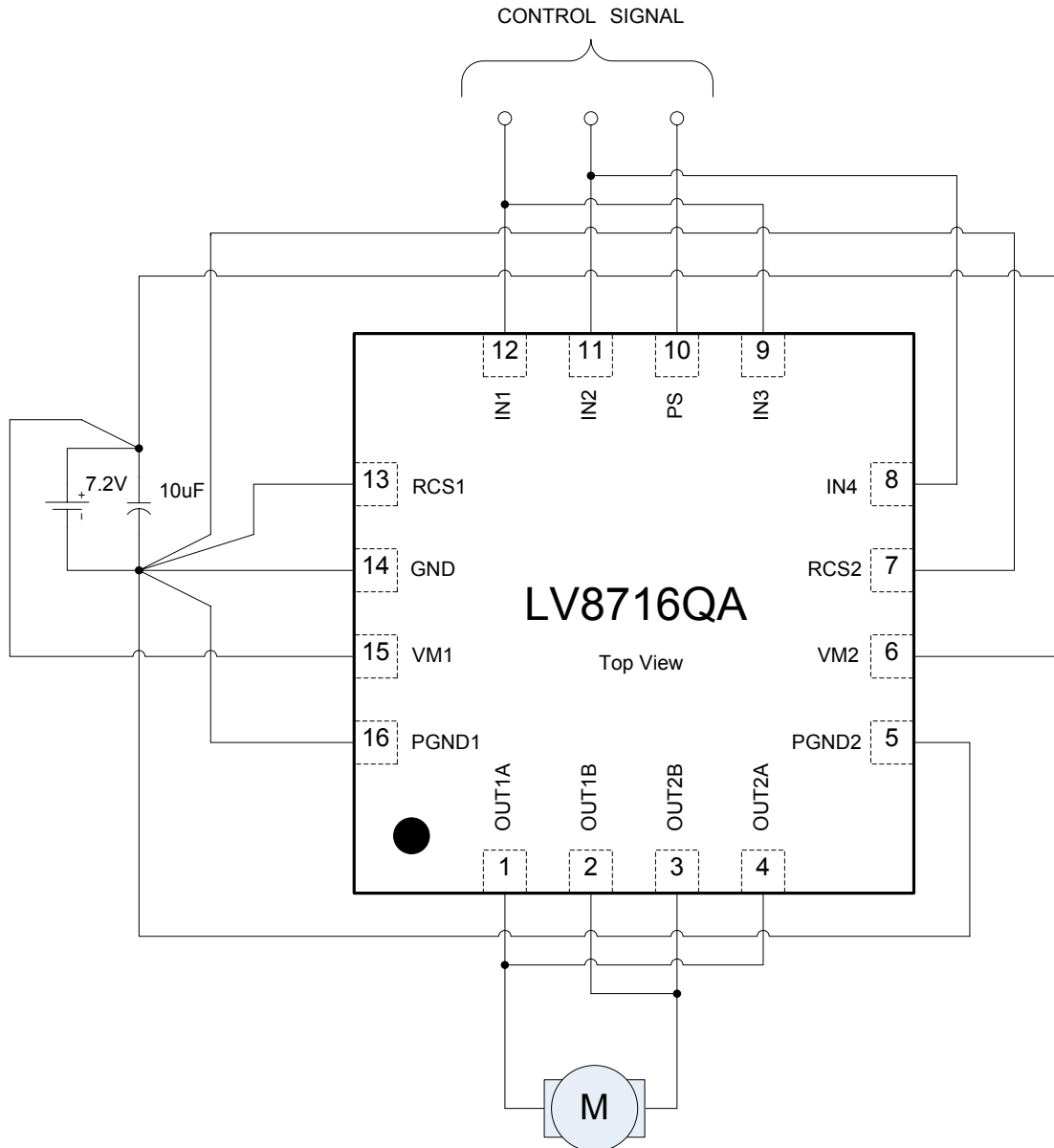

LV8716QA can drive a large current DC motor by connecting two H-bridges to parallel.

$$I_{\text{max}} = 2\text{A}$$

$$I_{\text{max}} = 3\text{A} \text{ (} t_w \leq 10\text{ms)}$$

When it connects H-bridge to parallel,

LV8716QA cannot use the internal PWM constant current control function.

Please connect the RCS pin to GND.

# LV8716QA

## 6-3) 2ch DC motor driver circuit

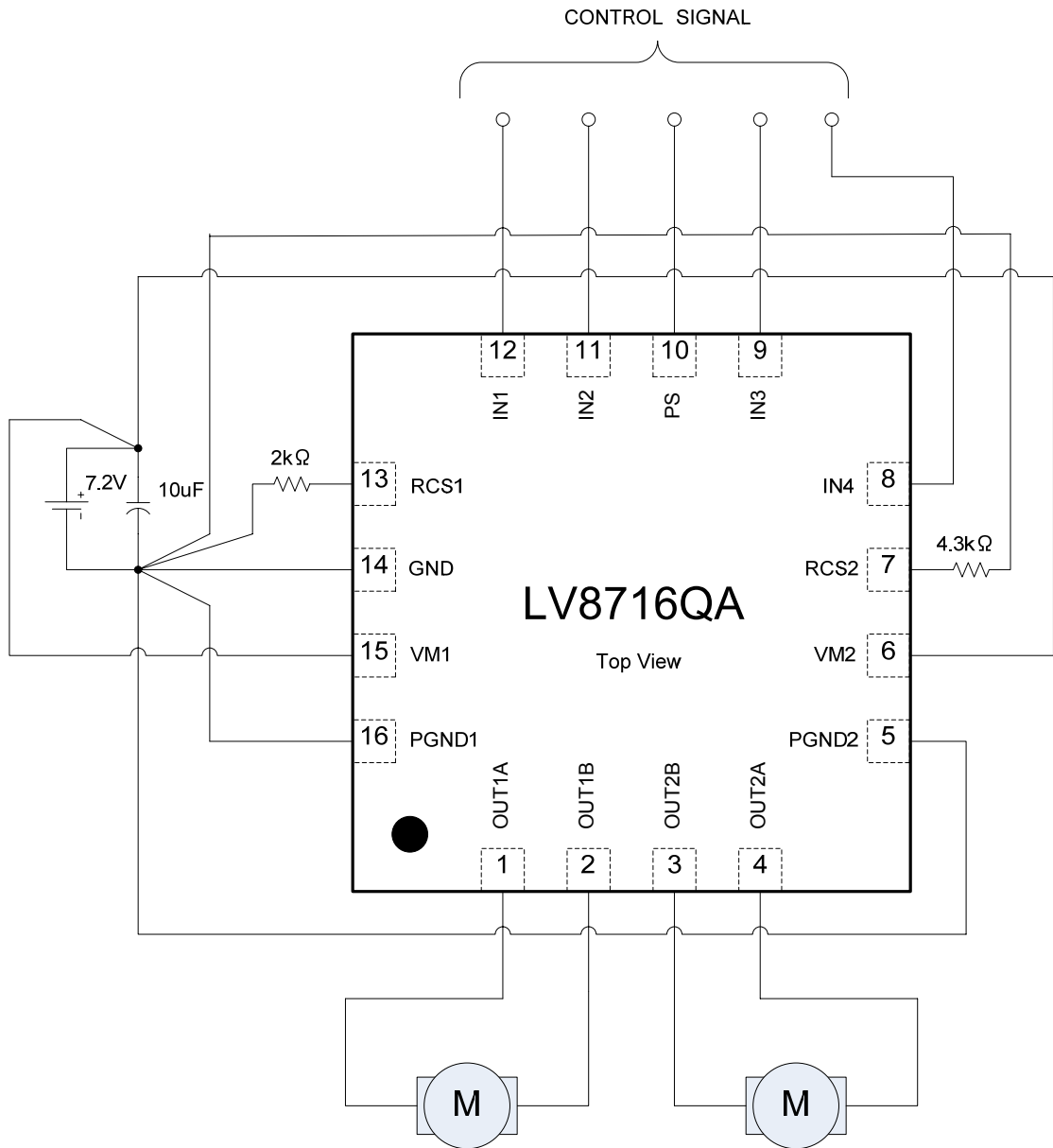

The formulae for setting the PWM constant current above is as follows :

When  $RCS1 = 2k\Omega$ ,  $RCS2 = 4.3k\Omega$

$$I_{out} = 0.2/2k\Omega \times 4000 = 400mA$$

$$I_{out} = 0.2/4.3k\Omega \times 4000 = 186mA$$

# LV8716QA

## ORDERING INFORMATION

Device	Package	Shipping (Qty / Packing)
LV8716QA-MH	QFN16 3x3, 0.5P (Pb-Free / Halogen Free)	3000 / Tape & Reel

ON Semiconductor and the ON logo are registered trademarks of Semiconductor Components Industries, LLC (SCILLC) or its subsidiaries in the United States and/or other countries. SCILLC owns the rights to a number of patents, trademarks, copyrights, trade secrets, and other intellectual property. A listing of SCILLC's product/patent coverage may be accessed at [www.onsemi.com/site/pdf/Patent-Marking.pdf](http://www.onsemi.com/site/pdf/Patent-Marking.pdf). SCILLC reserves the right to make changes without further notice to any products herein. SCILLC makes no warranty, representation or guarantee regarding the suitability of its products for any particular purpose, nor does SCILLC assume any liability arising out of the application or use of any product or circuit, and specifically disclaims any and all liability, including without limitation special, consequential or incidental damages. "Typical" parameters which may be provided in SCILLC data sheets and/or specifications can and do vary in different applications and actual performance may vary over time. All operating parameters, including "Typicals" must be validated for each customer application by customer's technical experts. SCILLC does not convey any license under its patent rights nor the rights of others. SCILLC products are not designed, intended, or authorized for use as components in systems intended for surgical implant into the body, or other applications intended to support or sustain life, or for any other application in which the failure of the SCILLC product could create a situation where personal injury or death may occur. Should Buyer purchase or use SCILLC products for any such unintended or unauthorized application, Buyer shall indemnify and hold SCILLC and its officers, employees, subsidiaries, affiliates, and distributors harmless against all claims, costs, damages, and expenses, and reasonable attorney fees arising out of, directly or indirectly, any claim of personal injury or death associated with such unintended or unauthorized use, even if such claim alleges that SCILLC was negligent regarding the design or manufacture of the part. SCILLC is an Equal Opportunity/Affirmative Action Employer. This literature is subject to all applicable copyright laws and is not for resale in any manner.



Компания «ЭлектроПласт» предлагает заключение долгосрочных отношений при поставках импортных электронных компонентов на взаимовыгодных условиях!

Наши преимущества:

- Оперативные поставки широкого спектра электронных компонентов отечественного и импортного производства напрямую от производителей и с крупнейших мировых складов;
- Поставка более 17-ти миллионов наименований электронных компонентов;
- Поставка сложных, дефицитных, либо снятых с производства позиций;
- Оперативные сроки поставки под заказ (от 5 рабочих дней);
- Экспресс доставка в любую точку России;
- Техническая поддержка проекта, помощь в подборе аналогов, поставка прототипов;
- Система менеджмента качества сертифицирована по Международному стандарту ISO 9001;
- Лицензия ФСБ на осуществление работ с использованием сведений, составляющих государственную тайну;
- Поставка специализированных компонентов (Xilinx, Altera, Analog Devices, Intersil, Interpoint, Microsemi, Aeroflex, Peregrine, Syfer, Eurofarad, Texas Instrument, Miteq, Cobham, E2V, MA-COM, Hittite, Mini-Circuits, General Dynamics и др.);

Помимо этого, одним из направлений компании «ЭлектроПласт» является направление «Источники питания». Мы предлагаем Вам помощь Конструкторского отдела:

- Подбор оптимального решения, техническое обоснование при выборе компонента;
- Подбор аналогов;
- Консультации по применению компонента;
- Поставка образцов и прототипов;
- Техническая поддержка проекта;
- Защита от снятия компонента с производства.



#### Как с нами связаться

**Телефон:** 8 (812) 309 58 32 (многоканальный)

**Факс:** 8 (812) 320-02-42

**Электронная почта:** [org@eplast1.ru](mailto:org@eplast1.ru)

**Адрес:** 198099, г. Санкт-Петербург, ул. Калинина, дом 2, корпус 4, литера А.