

# General Specifications

## Electrical Capacity (Resistive Load)

**Power Level (silver):** 3A @ 125V AC or 3A @ 250V AC or 3A @ 30V DC

## Other Ratings

**Contact Resistance:** 50 milliohms maximum  
**Insulation Resistance:** 200 megohms minimum @ 500V DC  
**Dielectric Strength:** 1,000V AC minimum between contacts for 1 minute minimum  
 1,500V AC minimum between contacts and case for 1 minute minimum  
**Mechanical Life:** 500,000 operations minimum  
**Electrical Life:** 50,000 operations minimum for 3A @ 125V/250V AC & 3A @ 30V DC  
 100,000 operations minimum for 1A @ 125V/250V AC & 1A @ 30V DC  
**Nominal Operating Force:** 1.5N for Single Pole; 3.0N for Double Pole  
**Contact Timing:** Nonshorting (break-before-make)  
**Travel:** Total Travel .118" (3.0mm)

## Materials & Finishes

**Actuator:** Polycarbonate  
**Housing:** Bushing mount: Glass fiber reinforced polyamide (UL94V-0);  
 Snap in mount: Polyphenylene ether (UL94V-0)  
**Base:** Diallyl phthalate (UL94V-0)  
**Movable Contact:** Phosphor bronze & silver with silver plating  
**Stationary Contacts:** Common terminal: Phosphor bronze with silver plating;  
 Contact terminals: Phosphor bronze with tin & copper plating  
**Lamp Terminals:** Phosphor bronze with tin and copper plating

## Environmental Data

**Operating Temperature Range:** -10°C through +50°C (+14°F through +122°F) for Illuminated  
 -25°C through +70°C (+13°F through +158°F) for Nonilluminated  
**Humidity:** 90 ~ 95% humidity for 240 hours @ 40°C (104°F)  
**Vibration:** 10 ~ 55Hz with peak-to-peak amplitude of 1.5mm traversing the frequency range & returning in 1 minute; 3 right angled directions for 2 hours  
**Shock:** 50G (490m/s<sup>2</sup>) acceleration (tested in 6 right angled directions, with 5 shocks in each direction)

## Installation

**Mounting Torque:** 0.8Nm (7.08 lb•in)  
**Soldering Time & Temperature:** Manual Soldering: See Profile A in Supplement section.  
**Cleaning:** Hand clean locally with alcohol based solution

## Standards & Certifications

**Flammability Standards:** UL94V-0 housing & base  
**UL:** **File No. E44145 - Recognized only when ordered with marking on switch.**  
 Add "/U" or "/CUL" to end of part number to order UL recognized switch.  
 All single & double pole models recognized at 3A @ 125V/250V AC or 3A @ 30V DC.

# Distinctive Characteristics

Environmentally friendly components and packaging materials meet RoHS Directive restricting use of hazardous materials. Suited for lead-free soldering because of heat resistant resin materials.

Smooth, slightly concave surface of cap designed to fit fingertip. Unique design and construction of cap prevents its removal and limits tampering.

Bright LED illumination in choice of red, green, or amber through translucent white cap.

Short body of .551" (14.0mm) conserves behind-panel space.

Combination solder lug and .110" quick connect terminals.

Crisp actuation and clear circuit status provided by snap-action contact mechanism. Arc barrier between movable contacts protects against crossover.

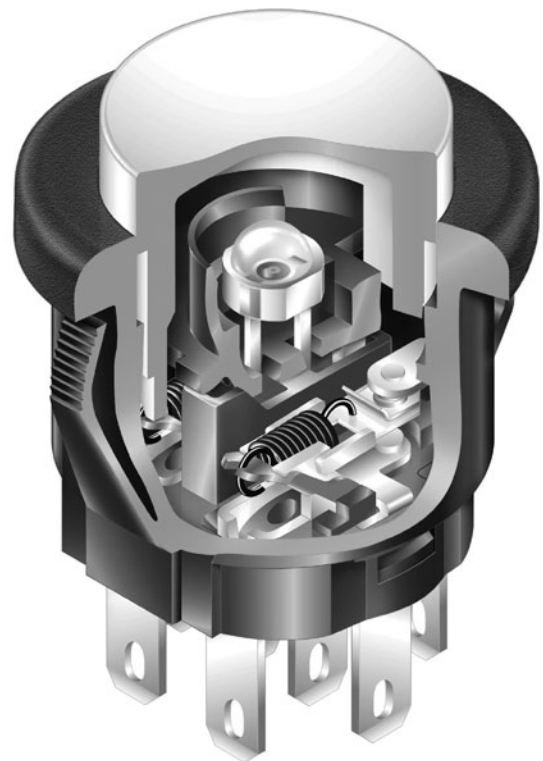

Actual Size

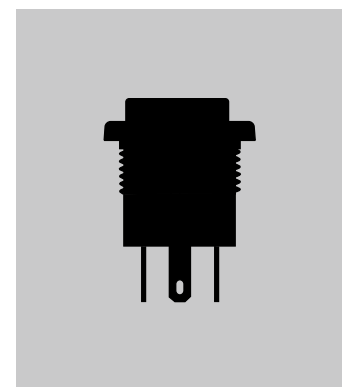

### TYPICAL SWITCH ORDERING EXAMPLE

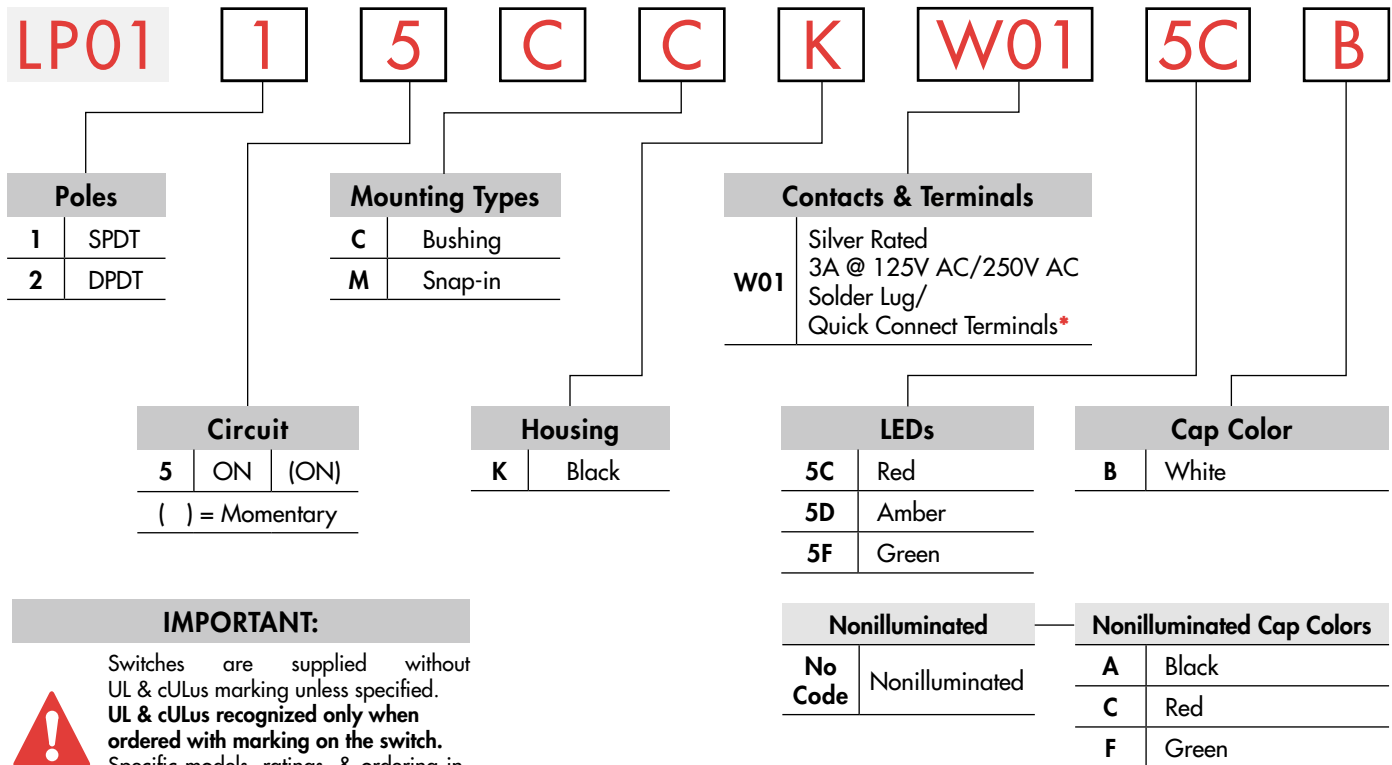

#### IMPORTANT:



Switches are supplied without UL & cULus marking unless specified. **UL & cULus recognized only when ordered with marking on the switch.** Specific models, ratings, & ordering instructions are noted on General Specifications page.

#### DESCRIPTION FOR TYPICAL ORDERING EXAMPLE

**LP0115CCKW015CB**

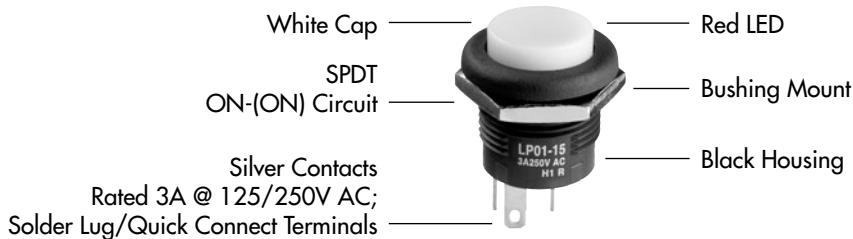

\* Wire harness & cable assemblies offered only in Americas

### POLES & CIRCUIT

Pole	Model	Plunger Position ( ) = Momentary		Connected Terminals		Throw & Power/Lamp Schematics
		Normal	Down	Normal	Down	
SP	LP0115	ON	(ON)	1-3	1-2	Note: Terminal markings "COM, NO, NC, L, + and -" are actually on the switch; terminal numbers are not on the switch. 
DP	LP0125	ON	(ON)	1-3 4-6	1-2 4-5	

## MOUNTING TYPES

**C**

**Bushing**

.630" (16.0mm) Diameter

This mounting option is supplied with a brass hexagon nut with nickel plating.



**M**

**Snap-in**

.669" (17.0mm) Diameter



Recommended Panel Thickness:  
.079" ~ .256"  
(2.0mm ~ 6.5mm)

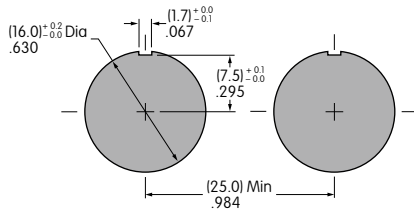

Allow .984" (25.0mm) distance from center-to-center between switches when mounted side-by-side.

Recommended Panel Thickness:  
.039" ~ .126"  
(1.0mm ~ 3.2mm)

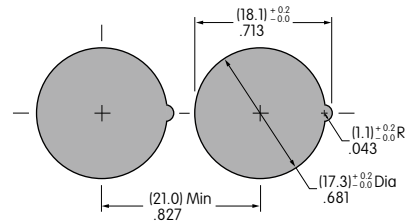

Allow .827" (21.0mm) distance from center-to-center between switches when mounted side-by-side.

## HOUSING

**K**

**Black**

Housing available in black only. The one-piece body and bezel have a matte finish.

## CONTACT MATERIALS, RATINGS, & TERMINALS

**W01**

**Silver**

**Power Level**

**Solder Lug/  
.110" (2.8mm) Quick Connect**

**3A @ 125V AC/250V AC; 3A @ 30V DC**

Note: If used at 1A @ 125V AC/250V AC or 1A @ 30V DC, electrical life will be 100,000 operations minimum.

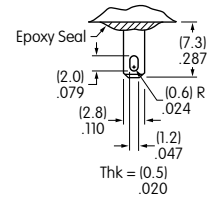

## LED COLORS & SPECIFICATIONS

The electrical specifications shown are determined at a basic temperature of 25°C. LED circuit is isolated and requires external power source. Polarity marks are on the switch. If the source voltage exceeds the rated voltage, a ballast resistor is required. The resistor value can be calculated by using the formula in the Supplement section.

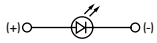
LEDs are an integral part of the switch and are not available separately.	Single Color LED with 1 Element		<b>5C</b>	<b>5D</b>	<b>5F</b>
		Colors	Red	Amber	Green
	Forward Peak Current	$I_{FM}$	30mA	30mA	30mA
	Typical Forward Current	$I_F$	20mA	20mA	20mA
	Forward Voltage	$V_F$	1.95V	2.0V	2.1V
	Reverse Peak Voltage	$V_{RM}$	5V	5V	5V
	Current Reduction Rate Above 25°C	$\Delta I_F$	0.41mA/°C	0.29mA/°C	0.39mA/°C
Ambient Temperature Range		-10°C ~ +50°C			

**No Code**

**No Lamp**

Toggles

Rockers

Pushbuttons

Illuminated PB

Programmable

Keylocks

Rotaries

Slides

Tactiles

Tilt

Touch

Indicators

Accessories

Supplement

### CAP COLORS

#### Illuminated Cap

Cap Color Available:



**White**

The translucent cap is an integral part of the switch and is not available separately.

Material: Polycarbonate      Finish: Matte



#### Nonilluminated Caps

Cap Colors Available:



**Black**



**Red**



**Green**

The cap is an integral part of the switch and is not available separately.

Material: Polycarbonate      Finish: Matte



### TYPICAL SWITCH DIMENSIONS

#### Bushing Mount • Single Pole

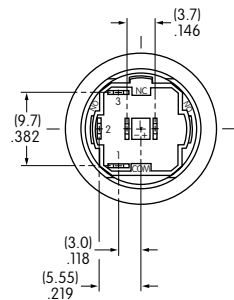
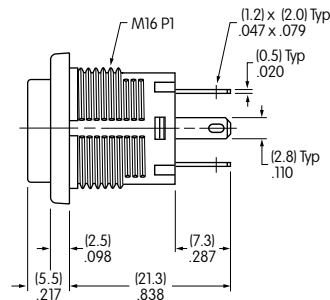
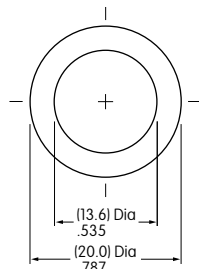

**LP0115CCKW015CB**

#### Bushing Mount • Double Pole

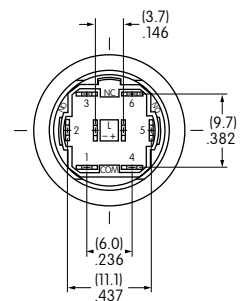
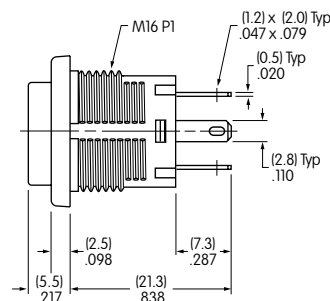
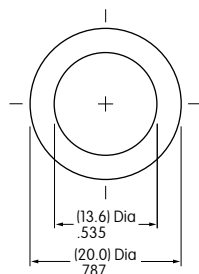

**LP0125CCKW015CB**

TYPICAL SWITCH DIMENSIONS

Snap-in • Single Pole

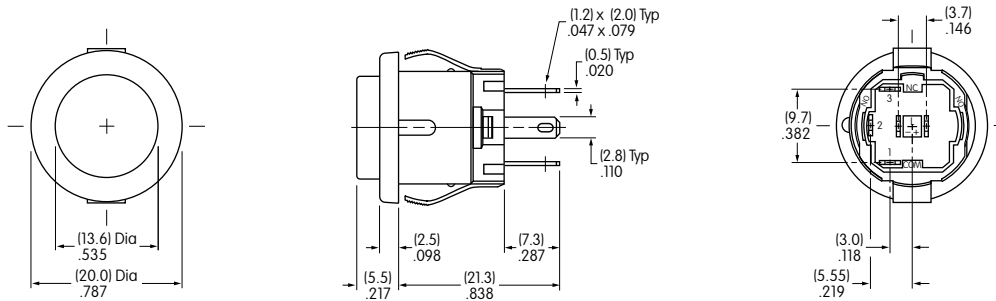

LP0115CMKW015CB

Snap-in • Double Pole

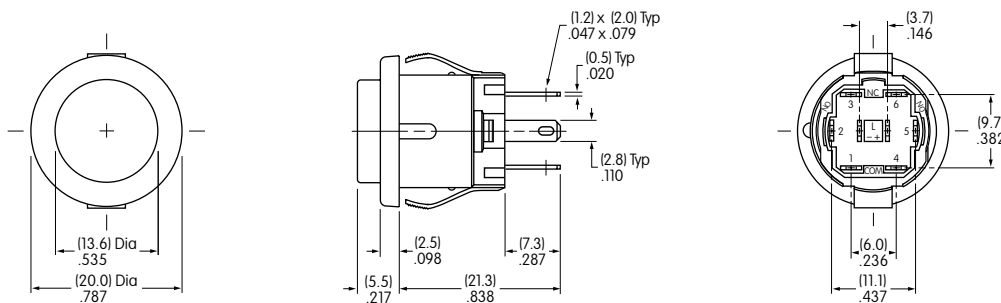

LP0125CMKW015DB

LEGENDS

NKK Switches can provide custom legends for caps. Contact factory for more information.

Suggested Printable Area for LP01 Cap



**Recommended Methods:**  
Pad Print or Laser Etch on cap.  
Epoxy based ink is recommended.

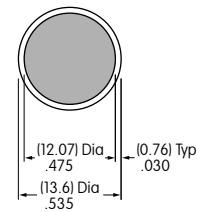

Shaded area is printable area

- Toggle
- Rockers
- Pushbuttons
- Illuminated PB**
- Programmable
- Keylocks
- Rotaries
- Slides
- Tactiles
- Tilt
- Touch
- Indicators
- Accessories
- Supplement



Компания «ЭлектроПласт» предлагает заключение долгосрочных отношений при поставках импортных электронных компонентов на взаимовыгодных условиях!

Наши преимущества:

- Оперативные поставки широкого спектра электронных компонентов отечественного и импортного производства напрямую от производителей и с крупнейших мировых складов;
- Поставка более 17-ти миллионов наименований электронных компонентов;
- Поставка сложных, дефицитных, либо снятых с производства позиций;
- Оперативные сроки поставки под заказ (от 5 рабочих дней);
- Экспресс доставка в любую точку России;
- Техническая поддержка проекта, помощь в подборе аналогов, поставка прототипов;
- Система менеджмента качества сертифицирована по Международному стандарту ISO 9001;
- Лицензия ФСБ на осуществление работ с использованием сведений, составляющих государственную тайну;
- Поставка специализированных компонентов (Xilinx, Altera, Analog Devices, Intersil, Interpoint, Microsemi, Aeroflex, Peregrine, Syfer, Eurofarad, Texas Instrument, Miteq, Cobham, E2V, MA-COM, Hittite, Mini-Circuits, General Dynamics и др.);

Помимо этого, одним из направлений компании «ЭлектроПласт» является направление «Источники питания». Мы предлагаем Вам помощь Конструкторского отдела:

- Подбор оптимального решения, техническое обоснование при выборе компонента;
- Подбор аналогов;
- Консультации по применению компонента;
- Поставка образцов и прототипов;
- Техническая поддержка проекта;
- Защита от снятия компонента с производства.



#### Как с нами связаться

**Телефон:** 8 (812) 309 58 32 (многоканальный)

**Факс:** 8 (812) 320-02-42

**Электронная почта:** [org@eplast1.ru](mailto:org@eplast1.ru)

**Адрес:** 198099, г. Санкт-Петербург, ул. Калинина, дом 2, корпус 4, литера А.