

MC10EP105, MC100EP105

3.3V / 5V ECL Quad 2-Input Differential AND/NAND

Description

The MC10/100EP105 is a quad 2-input differential AND/NAND gate. Each gate is functionally equivalent to the EP05 and LVEL05 devices. With AC performance much faster than the LVEL05 device, the EP105 is ideal for applications requiring the fastest AC performance available.

The 100 Series contains temperature compensation.

Features

- 275 ps Typical Propagation Delay
- Maximum Frequency > 3 GHz Typical
- PECL Mode Operating Range: $V_{CC} = 3.0\text{ V}$ to 5.5 V with $V_{EE} = 0\text{ V}$
- NECL Mode Operating Range: $V_{CC} = 0\text{ V}$ with $V_{EE} = -3.0\text{ V}$ to -5.5 V
- Open Input Default State
- Safety Clamp on Inputs
- Pb-Free Packages are Available*



ON Semiconductor®

<http://onsemi.com>

MARKING DIAGRAMS*



LQFP-32
FA SUFFIX
CASE 873A

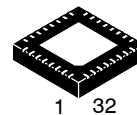
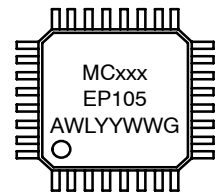

QFN32
MN SUFFIX
CASE 488AM

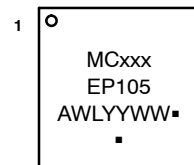

xxx = 10 or 100
A = Assembly Location
WL, L = Wafer Lot
YY, Y = Year
WW, W = Work Week
G or ▪ = Pb-Free Package

(Note: Microdot may be in either location)

*For additional marking information, refer to Application Note AND8002/D.

ORDERING INFORMATION

See detailed ordering and shipping information in the package dimensions section on page 9 of this data sheet.

*For additional information on our Pb-Free strategy and soldering details, please download the ON Semiconductor Soldering and Mounting Techniques Reference Manual, SOLDERRM/D.

MC10EP105, MC100EP105

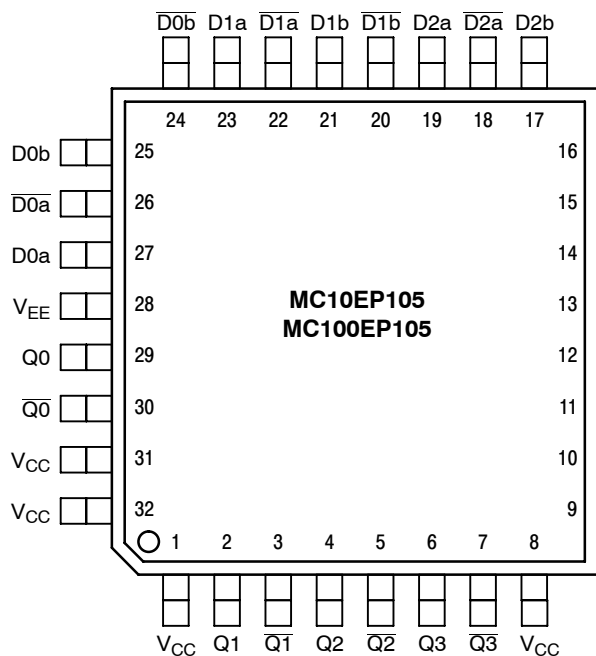

Warning: All V_{CC} and V_{EE} pins must be externally connected to Power Supply to guarantee proper operation.

Figure 1. 32-Lead LQFP Pinout (Top View)

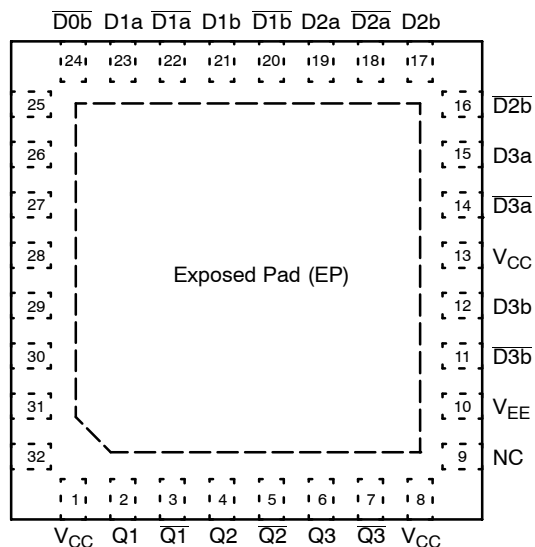

Figure 2. 32-Lead QFN Pinout (Top View)

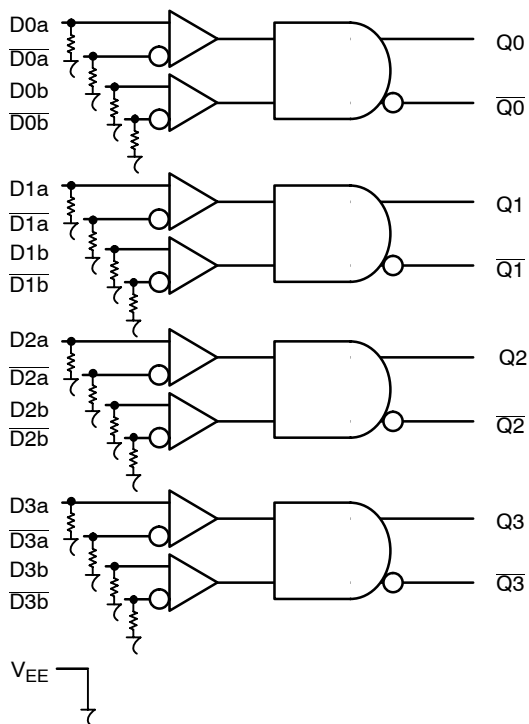

Figure 3. Logic Diagram

Table 1. PIN DESCRIPTION

| PIN | FUNCTION |
|----------------------------------------------------|------------------|
| Dna*, Dnb*, \overline{Dna} *, \overline{Dnb} * | ECL Data Inputs |
| Qn, \overline{Qn} | ECL Data Outputs |
| V _{CC} | Positive Supply |
| V _{EE} | Negative Supply |
| NC | No Connect |

* Pins will default LOW when left open.

Table 2. TRUTH TABLE

| Dna | Dnb | \overline{Dna} | \overline{Dnb} | Qn | \overline{Qn} |
|-----|-----|------------------|------------------|----|-----------------|
| L | L | H | H | L | H |
| L | H | H | L | L | H |
| H | L | L | H | L | H |
| H | H | L | L | H | L |

MC10EP105, MC100EP105

Table 3. ATTRIBUTES

| Characteristics | Value | |
|---------------------------------------------------------------|-----------------------------------------------------------|------------------------------------|
| Internal Input Pulldown Resistor | 75 kΩ | |
| Internal Input Pullup Resistor | N/A | |
| ESD Protection | Human Body Model Machine Model Charged Device Model | > 4 kV > 100 V > 2 kV |
| Moisture Sensitivity, Indefinite Time Out of Drypack (Note 1) | Pb Pkg | Pb-Free Pkg |
| | LQFP-32 QFN-32 | Level 2 - Level 2 Level 1 |
| Flammability Rating | Oxygen Index: 28 to 34 | UL-94 V-0 @ 0.125 in |
| Transistor Count | 444 Devices | |
| Meets or exceeds JEDEC Spec EIA/JESD78 IC Latchup Test | | |

1. For additional information, see Application Note AND8003/D.

Table 4. MAXIMUM RATINGS

| Symbol | Parameter | Condition 1 | Condition 2 | Rating | Unit |
|------------------|----------------------------------------------------|------------------------------------------------|----------------------------------------------------------------------|-------------|------|
| V _{CC} | PECL Mode Power Supply | V _{EE} = 0 V | | 6 | V |
| V _{EE} | NECL Mode Power Supply | V _{CC} = 0 V | | -6 | V |
| V _I | PECL Mode Input Voltage NECL Mode Input Voltage | V _{EE} = 0 V V _{CC} = 0 V | V _I ≤ V _{CC} V _I ≥ V _{EE} | 6 -6 | V |
| I _{out} | Output Current | Continuous Surge | | 50 100 | mA |
| I _{BB} | V _{BB} Sink/Source | | | ± 0.5 | mA |
| T _A | Operating Temperature Range | | | -40 to +85 | °C |
| T _{stg} | Storage Temperature Range | | | -65 to +150 | °C |
| θ _{JA} | Thermal Resistance (Junction-to-Ambient) | 0 lfpm 500 lfpm | 32 LQFP 32 LQFP | 80 55 | °C/W |
| θ _{JC} | Thermal Resistance (Junction-to-Case) | Standard Board | 32 LQFP | 12 to 17 | °C/W |
| θ _{JA} | Thermal Resistance (Junction-to-Ambient) | 0 lfpm 500 lfpm | 32 QFN 32 QFN | 31 27 | °C/W |
| θ _{JC} | Thermal Resistance (Junction-to-Case) | 2S2P | 32 QFN | 12 | °C/W |
| T _{sol} | Wave Solder | Pb Pb-Free | <2 to 3 sec @ 248°C <2 to 3 sec @ 260°C | 265 265 | °C |

Stresses exceeding Maximum Ratings may damage the device. Maximum Ratings are stress ratings only. Functional operation above the Recommended Operating Conditions is not implied. Extended exposure to stresses above the Recommended Operating Conditions may affect device reliability.

MC10EP105, MC100EP105

Table 5. 10EP DC CHARACTERISTICS, PECL $V_{CC} = 3.3\text{ V}$, $V_{EE} = 0\text{ V}$ (Note 2)

| Symbol | Characteristic | -40°C | | | 25°C | | | 85°C | | | Unit |
|-------------|----------------------------------------------------------------------------|-------|------|------|------|------|------|------|------|------|---------------|
| | | Min | Typ | Max | Min | Typ | Max | Min | Typ | Max | |
| I_{EE} | Power Supply Current | 45 | 58 | 75 | 45 | 59 | 75 | 45 | 60 | 75 | mA |
| V_{OH} | Output HIGH Voltage (Note 3) | 2165 | 2290 | 2415 | 2230 | 2355 | 2480 | 2290 | 2415 | 2540 | mV |
| V_{OL} | Output LOW Voltage (Note 3) | 1365 | 1490 | 1615 | 1430 | 1555 | 1680 | 1490 | 1615 | 1740 | mV |
| V_{IH} | Input HIGH Voltage (Single-Ended) | 2090 | | 2415 | 2155 | | 2480 | 2215 | | 2540 | mV |
| V_{IL} | Input LOW Voltage (Single-Ended) | 1365 | | 1690 | 1460 | | 1755 | 1490 | | 1815 | mV |
| V_{IHCMR} | Input HIGH Voltage Common Mode Range (Differential Configuration) (Note 4) | 2.0 | | 3.3 | 2.0 | | 3.3 | 2.0 | | 3.3 | V |
| I_{IH} | Input HIGH Current | | | 150 | | | 150 | | | 150 | μA |
| I_{IL} | Input LOW Current | 0.5 | | | 0.5 | | | 0.5 | | | μA |

NOTE: Device will meet the specifications after thermal equilibrium has been established when mounted in a test socket or printed circuit board with maintained transverse airflow greater than 500 lfm. Electrical parameters are guaranteed only over the declared operating temperature range. Functional operation of the device exceeding these conditions is not implied. Device specification limit values are applied individually under normal operating conditions and not valid simultaneously.

2. Input and output parameters vary 1:1 with V_{CC} . V_{EE} can vary +0.3 V to -2.2 V.
3. All loading with 50 Ω to $V_{CC} - 2.0\text{ V}$.
4. V_{IHCMR} min varies 1:1 with V_{EE} . V_{IHCMR} max varies 1:1 with V_{CC} . The V_{IHCMR} range is referenced to the most positive side of the differential input signal.

MC10EP105, MC100EP105

Table 6. 10EP DC CHARACTERISTICS, PECL $V_{CC} = 5.0\text{ V}$, $V_{EE} = 0\text{ V}$ (Note 5)

| Symbol | Characteristic | -40°C | | | 25°C | | | 85°C | | | Unit |
|-------------|----------------------------------------------------------------------------|-------|------|------|------|------|------|------|------|------|---------------|
| | | Min | Typ | Max | Min | Typ | Max | Min | Typ | Max | |
| I_{EE} | Power Supply Current | 45 | 58 | 75 | 45 | 59 | 75 | 45 | 60 | 75 | mA |
| V_{OH} | Output HIGH Voltage (Note 6) | 3865 | 3990 | 4115 | 3930 | 4055 | 4180 | 3990 | 4115 | 4240 | mV |
| V_{OL} | Output LOW Voltage (Note 6) | 3065 | 3190 | 3315 | 3130 | 3255 | 3380 | 3190 | 3315 | 3440 | mV |
| V_{IH} | Input HIGH Voltage (Single-Ended) | 3790 | | 4115 | 3855 | | 4180 | 3915 | | 4240 | mV |
| V_{IL} | Input LOW Voltage (Single-Ended) | 3065 | | 3390 | 3130 | | 3455 | 3190 | | 3515 | mV |
| V_{IHCMR} | Input HIGH Voltage Common Mode Range (Differential Configuration) (Note 7) | 2.0 | | 5.0 | 2.0 | | 5.0 | 2.0 | | 5.0 | V |
| I_{IH} | Input HIGH Current | | | 150 | | | 150 | | | 150 | μA |
| I_{IL} | Input LOW Current | 0.5 | | | 0.5 | | | 0.5 | | | μA |

NOTE: Device will meet the specifications after thermal equilibrium has been established when mounted in a test socket or printed circuit board with maintained transverse airflow greater than 500 lfm. Electrical parameters are guaranteed only over the declared operating temperature range. Functional operation of the device exceeding these conditions is not implied. Device specification limit values are applied individually under normal operating conditions and not valid simultaneously.

5. Input and output parameters vary 1:1 with V_{CC} . V_{EE} can vary +2.0 V to -0.5 V.

6. All loading with 50 Ω to $V_{CC} - 2.0\text{ V}$.

7. V_{IHCMR} min varies 1:1 with V_{EE} . V_{IHCMR} max varies 1:1 with V_{CC} . The V_{IHCMR} range is referenced to the most positive side of the differential input signal.

Table 7. 10EP DC CHARACTERISTICS, NECL $V_{CC} = 0\text{ V}$, $V_{EE} = -5.5\text{ V}$ to -3.0 V (Note 8)

| Symbol | Characteristic | -40°C | | | 25°C | | | 85°C | | | Unit |
|-------------|-----------------------------------------------------------------------------|--------------|-------|-------|--------------|-------|-------|--------------|-------|-------|---------------|
| | | Min | Typ | Max | Min | Typ | Max | Min | Typ | Max | |
| I_{EE} | Power Supply Current | 45 | 58 | 75 | 45 | 59 | 75 | 45 | 60 | 75 | mA |
| V_{OH} | Output HIGH Voltage (Note 9) | -1135 | -1010 | -885 | -1070 | -945 | -820 | -1010 | -885 | -760 | mV |
| V_{OL} | Output LOW Voltage (Note 9) | -1935 | -1810 | -1685 | -1870 | -1745 | -1620 | -1810 | -1685 | -1560 | mV |
| V_{IH} | Input HIGH Voltage (Single-Ended) | -1210 | | -885 | -1145 | | -820 | -1085 | | -760 | mV |
| V_{IL} | Input LOW Voltage (Single-Ended) | -1935 | | -1610 | -1870 | | -1545 | -1810 | | -1485 | mV |
| V_{IHCMR} | Input HIGH Voltage Common Mode Range (Differential Configuration) (Note 10) | $V_{EE}+2.0$ | | 0.0 | $V_{EE}+2.0$ | | 0.0 | $V_{EE}+2.0$ | | 0.0 | V |
| I_{IH} | Input HIGH Current | | | 150 | | | 150 | | | 150 | μA |
| I_{IL} | Input LOW Current | 0.5 | | | 0.5 | | | 0.5 | | | μA |

NOTE: Device will meet the specifications after thermal equilibrium has been established when mounted in a test socket or printed circuit board with maintained transverse airflow greater than 500 lfm. Electrical parameters are guaranteed only over the declared operating temperature range. Functional operation of the device exceeding these conditions is not implied. Device specification limit values are applied individually under normal operating conditions and not valid simultaneously.

8. Input and output parameters vary 1:1 with V_{CC} .

9. All loading with 50 Ω to $V_{CC} - 2.0\text{ V}$.

10. V_{IHCMR} min varies 1:1 with V_{EE} . V_{IHCMR} max varies 1:1 with V_{CC} . The V_{IHCMR} range is referenced to the most positive side of the differential input signal.

MC10EP105, MC100EP105

Table 8. 100EP DC CHARACTERISTICS, PECL $V_{CC} = 3.3\text{ V}$, $V_{EE} = 0\text{ V}$ (Note 11)

| Symbol | Characteristic | -40°C | | | 25°C | | | 85°C | | | Unit |
|-------------|-----------------------------------------------------------------------------|-------|------|------|------|------|------|------|------|------|---------------|
| | | Min | Typ | Max | Min | Typ | Max | Min | Typ | Max | |
| I_{EE} | Power Supply Current | 45 | 59 | 80 | 45 | 62 | 85 | 45 | 65 | 85 | mA |
| V_{OH} | Output HIGH Voltage (Note 12) | 2155 | 2280 | 2405 | 2155 | 2280 | 2405 | 2155 | 2280 | 2405 | mV |
| V_{OL} | Output LOW Voltage (Note 12) | 1355 | 1480 | 1605 | 1355 | 1480 | 1605 | 1355 | 1480 | 1605 | mV |
| V_{IH} | Input HIGH Voltage (Single-Ended) | 2075 | | 2420 | 2075 | | 2420 | 2075 | | 2420 | mV |
| V_{IL} | Input LOW Voltage (Single-Ended) | 1355 | | 1675 | 1355 | | 1675 | 1355 | | 1675 | mV |
| V_{IHCMR} | Input HIGH Voltage Common Mode Range (Differential Configuration) (Note 13) | 2.0 | | 3.3 | 2.0 | | 3.3 | 2.0 | | 3.3 | V |
| I_{IH} | Input HIGH Current | | | 150 | | | 150 | | | 150 | μA |
| I_{IL} | Input LOW Current | 0.5 | | | 0.5 | | | 0.5 | | | μA |

NOTE: Device will meet the specifications after thermal equilibrium has been established when mounted in a test socket or printed circuit board with maintained transverse airflow greater than 500 lfm. Electrical parameters are guaranteed only over the declared operating temperature range. Functional operation of the device exceeding these conditions is not implied. Device specification limit values are applied individually under normal operating conditions and not valid simultaneously.

11. Input and output parameters vary 1:1 with V_{CC} . V_{EE} can vary +0.3 V to -2.2 V.

12. All loading with 50 Ω to $V_{CC} - 2.0\text{ V}$.

13. V_{IHCMR} min varies 1:1 with V_{EE} . V_{IHCMR} max varies 1:1 with V_{CC} . The V_{IHCMR} range is referenced to the most positive side of the differential input signal.

Table 9. 100EP DC CHARACTERISTICS, PECL $V_{CC} = 5.0\text{ V}$, $V_{EE} = 0\text{ V}$ (Note 14)

| Symbol | Characteristic | -40°C | | | 25°C | | | 85°C | | | Unit |
|-------------|-----------------------------------------------------------------------------|-------|------|------|------|------|------|------|------|------|---------------|
| | | Min | Typ | Max | Min | Typ | Max | Min | Typ | Max | |
| I_{EE} | Power Supply Current | 45 | 63 | 80 | 45 | 66 | 85 | 45 | 69 | 85 | mA |
| V_{OH} | Output HIGH Voltage (Note 15) | 3855 | 3980 | 4105 | 3855 | 3980 | 4105 | 3855 | 3980 | 4105 | mV |
| V_{OL} | Output LOW Voltage (Note 15) | 3055 | 3180 | 3305 | 3055 | 3180 | 3305 | 3055 | 3180 | 3305 | mV |
| V_{IH} | Input HIGH Voltage (Single-Ended) | 3775 | | 4120 | 3775 | | 4120 | 3775 | | 4120 | mV |
| V_{IL} | Input LOW Voltage (Single-Ended) | 3055 | | 3375 | 3055 | | 3375 | 3055 | | 3375 | mV |
| V_{IHCMR} | Input HIGH Voltage Common Mode Range (Differential Configuration) (Note 16) | 2.0 | | 5.0 | 2.0 | | 5.0 | 2.0 | | 5.0 | V |
| I_{IH} | Input HIGH Current | | | 150 | | | 150 | | | 150 | μA |
| I_{IL} | Input LOW Current | 0.5 | | | 0.5 | | | 0.5 | | | μA |

NOTE: Device will meet the specifications after thermal equilibrium has been established when mounted in a test socket or printed circuit board with maintained transverse airflow greater than 500 lfm. Electrical parameters are guaranteed only over the declared operating temperature range. Functional operation of the device exceeding these conditions is not implied. Device specification limit values are applied individually under normal operating conditions and not valid simultaneously.

14. Input and output parameters vary 1:1 with V_{CC} . V_{EE} can vary +2.0 V to -0.5 V.

15. All loading with 50 Ω to $V_{CC} - 2.0\text{ V}$.

16. V_{IHCMR} min varies 1:1 with V_{EE} . V_{IHCMR} max varies 1:1 with V_{CC} . The V_{IHCMR} range is referenced to the most positive side of the differential input signal.

MC10EP105, MC100EP105

Table 10. 100EP DC CHARACTERISTICS, NECL $V_{CC} = 0\text{ V}$, $V_{EE} = -5.5\text{ V to } -3.0\text{ V}$ (Note 17)

| Symbol | Characteristic | -40°C | | | 25°C | | | 85°C | | | Unit |
|-------------|-----------------------------------------------------------------------------|--------------|----------|----------|--------------|----------|----------|--------------|----------|----------|---------------|
| | | Min | Typ | Max | Min | Typ | Max | Min | Typ | Max | |
| I_{EE} | Power Supply Current $V_{CC} = -3.3\text{ V}$ $V_{CC} = -5.0\text{ V}$ | 45 45 | 59 63 | 80 80 | 45 45 | 62 66 | 85 85 | 45 45 | 65 69 | 85 85 | mA |
| V_{OH} | Output HIGH Voltage (Note 18) | -1145 | -1020 | -895 | -1145 | -1020 | -895 | -1145 | -1020 | -895 | mV |
| V_{OL} | Output LOW Voltage (Note 18) | -1945 | -1820 | -1695 | -1945 | -1820 | -1695 | -1945 | -1820 | -1695 | mV |
| V_{IH} | Input HIGH Voltage (Single-Ended) | -1225 | | -880 | -1225 | | -880 | -1225 | | -880 | mV |
| V_{IL} | Input LOW Voltage (Single-Ended) | -1945 | | -1625 | -1945 | | -1625 | -1945 | | -1625 | mV |
| V_{IHCMR} | Input HIGH Voltage Common Mode Range (Differential Configuration) (Note 19) | $V_{EE}+2.0$ | | 0.0 | $V_{EE}+2.0$ | | 0.0 | $V_{EE}+2.0$ | | 0.0 | V |
| I_{IH} | Input HIGH Current | | | 150 | | | 150 | | | 150 | μA |
| I_{IL} | Input LOW Current | 0.5 | | | 0.5 | | | 0.5 | | | μA |

NOTE: Device will meet the specifications after thermal equilibrium has been established when mounted in a test socket or printed circuit board with maintained transverse airflow greater than 500 lfm. Electrical parameters are guaranteed only over the declared operating temperature range. Functional operation of the device exceeding these conditions is not implied. Device specification limit values are applied individually under normal operating conditions and not valid simultaneously.

17. Input and output parameters vary 1:1 with V_{CC} .

18. All loading with $50\ \Omega$ to $V_{CC} - 2.0\text{ V}$.

19. V_{IHCMR} min varies 1:1 with V_{EE} . V_{IHCMR} max varies 1:1 with V_{CC} . The V_{IHCMR} range is referenced to the most positive side of the differential input signal.

Table 11. AC CHARACTERISTICS $V_{CC} = 0\text{ V}$; $V_{EE} = -3.0\text{ V to } -5.5\text{ V}$ or $V_{CC} = 3.0\text{ V to } 5.5\text{ V}$; $V_{EE} = 0\text{ V}$ (Note 20)

| Symbol | Characteristic | -40°C | | | 25°C | | | 85°C | | | Unit | |
|--------------------------|--------------------------------------------------------|-------|-----|------|------|-----|------|------|-----|------|------|----|
| | | Min | Typ | Max | Min | Typ | Max | Min | Typ | Max | | |
| f_{max} | Maximum Frequency (See Figure 4 $F_{max}/JITTER$) | | > 3 | | | > 3 | | | > 3 | | GHz | |
| t_{PLH} , t_{PHL} | Propagation Delay to Output Differential | 175 | 250 | 325 | 200 | 275 | 350 | 225 | 300 | 375 | ps | |
| t_{SKEW} | Within Device Skew Device to Device Skew (Note 21) | | 10 | 50 | | 10 | 50 | | 15 | 50 | ps | |
| t_{JITTER} | Cycle-to-Cycle Jitter (See Figure 4 $F_{max}/JITTER$) | | 0.2 | < 1 | | 0.2 | < 1 | | 0.2 | < 1 | ps | |
| V_{PP} | Input Voltage Swing (Differential Configuration) | 150 | 800 | 1200 | 150 | 800 | 1200 | 150 | 800 | 1200 | mV | |
| t_r t_f | Output Rise/Fall Times (20% – 80%) | Q | 100 | 150 | 200 | 120 | 170 | 220 | 150 | 200 | 250 | ps |

NOTE: Device will meet the specifications after thermal equilibrium has been established when mounted in a test socket or printed circuit board with maintained transverse airflow greater than 500 lfm. Electrical parameters are guaranteed only over the declared operating temperature range. Functional operation of the device exceeding these conditions is not implied. Device specification limit values are applied individually under normal operating conditions and not valid simultaneously.

20. Measured using a 750 mV source, 50% duty cycle clock source. All loading with $50\ \Omega$ to $V_{CC} - 2.0\text{ V}$.

21. Skew is measured between outputs under identical transitions.

MC10EP105, MC100EP105

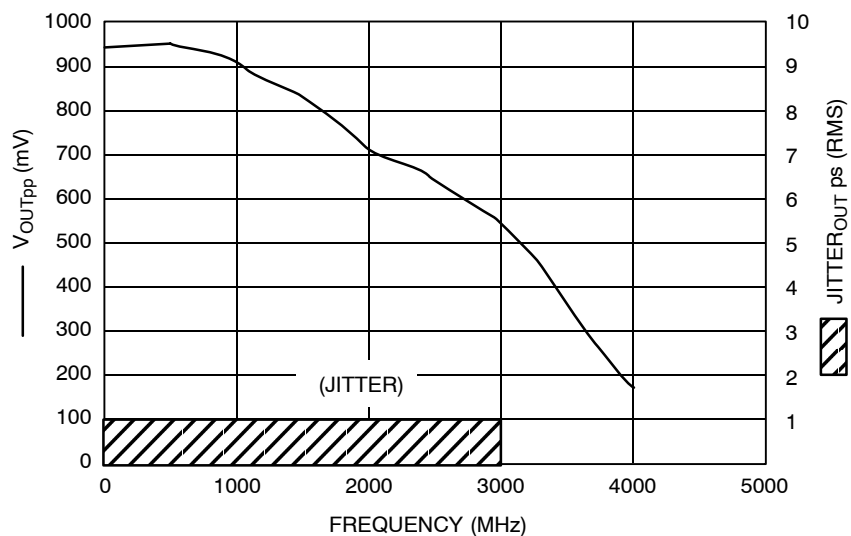

Figure 4. $F_{max}/Jitter$

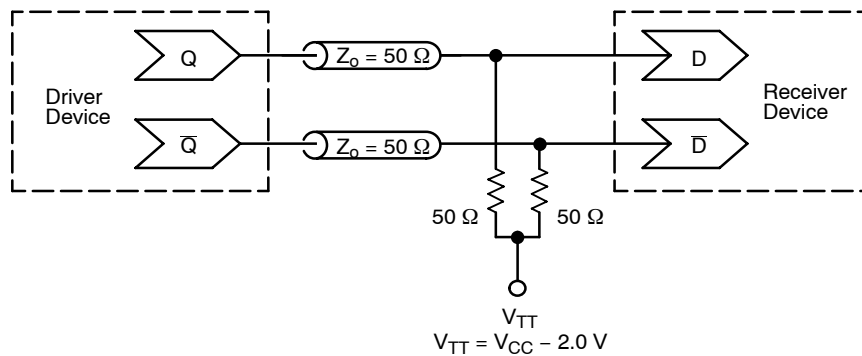

Figure 5. Typical Termination for Output Driver and Device Evaluation (See Application Note AND8020/D – Termination of ECL Logic Devices.)

MC10EP105, MC100EP105

ORDERING INFORMATION

| Device | Package | Shipping† |
|-----------------|----------------------|--------------------|
| MC10EP105FA | LQFP-32 | 250 Units / Tray |
| MC10EP105FAG | LQFP-32 (Pb-Free) | 250 Units / Tray |
| MC10EP105FAR2 | LQFP-32 | 2000 / Tape & Reel |
| MC10EP105FAR2G | LQFP-32 (Pb-Free) | 2000 / Tape & Reel |
| MC100EP105FA | LQFP-32 | 250 Units / Tray |
| MC100EP105FAG | LQFP-32 (Pb-Free) | 250 Units / Tray |
| MC100EP105FAR2 | LQFP-32 | 2000 / Tape & Reel |
| MC100EP105FAR2G | LQFP-32 (Pb-Free) | 2000 / Tape & Reel |
| MC10EP105MNG | QFN-32 (Pb-Free) | 74 Units / Rail |
| MC100EP105MNG | | 74 Units / Rail |
| MC10EP105MNR4G | | 1000 / Tape & Reel |
| MC100EP105MNR4G | | 1000 / Tape & Reel |

†For information on tape and reel specifications, including part orientation and tape sizes, please refer to our Tape and Reel Packaging Specifications Brochure, BRD8011/D.

Resource Reference of Application Notes

- AN1405/D** – ECL Clock Distribution Techniques
- AN1406/D** – Designing with PECL (ECL at +5.0 V)
- AN1503/D** – ECLinPS™ I/O SPiCE Modeling Kit
- AN1504/D** – Metastability and the ECLinPS Family
- AN1568/D** – Interfacing Between LVDS and ECL
- AN1672/D** – The ECL Translator Guide
- AND8001/D** – Odd Number Counters Design
- AND8002/D** – Marking and Date Codes
- AND8020/D** – Termination of ECL Logic Devices
- AND8066/D** – Interfacing with ECLinPS
- AND8090/D** – AC Characteristics of ECL Devices

MC10EP105, MC100EP105

PACKAGE DIMENSIONS

32 LEAD LQFP
CASE 873A-02
ISSUE C

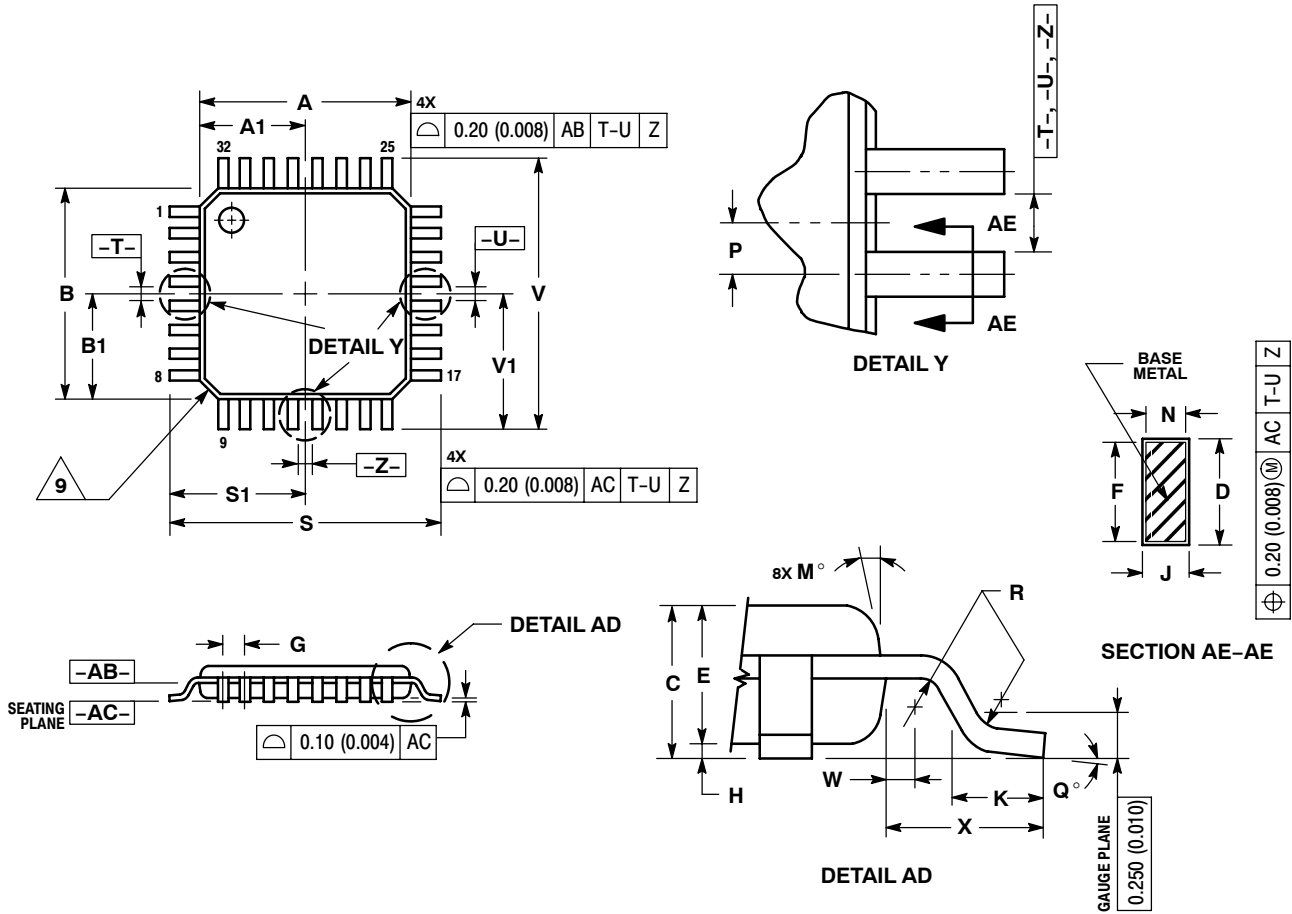

NOTES:

1. DIMENSIONING AND TOLERANCING PER ANSI Y14.5M, 1982.
2. CONTROLLING DIMENSION: MILLIMETER.
3. DATUM PLANE -AB- IS LOCATED AT BOTTOM OF LEAD AND IS COINCIDENT WITH THE LEAD WHERE THE LEAD EXITS THE PLASTIC BODY AT THE BOTTOM OF THE PARTING LINE.
4. DATUMS -T-, -U-, AND -Z- TO BE DETERMINED AT DATUM PLANE -AB-.
5. DIMENSIONS S AND V TO BE DETERMINED AT SEATING PLANE -AC-.
6. DIMENSIONS A AND B DO NOT INCLUDE MOLD PROTRUSION. ALLOWABLE PROTRUSION IS 0.250 (0.010) PER SIDE. DIMENSIONS A AND B DO INCLUDE MOLD MISMATCH AND ARE DETERMINED AT DATUM PLANE -AB-.
7. DIMENSION D DOES NOT INCLUDE DAMBAR PROTRUSION. DAMBAR PROTRUSION SHALL NOT CAUSE THE D DIMENSION TO EXCEED 0.520 (0.020).
8. MINIMUM SOLDER PLATE THICKNESS SHALL BE 0.0076 (0.0003).
9. EXACT SHAPE OF EACH CORNER MAY VARY FROM DEPICTION.

| DIM | MILLIMETERS | | INCHES | |
|-----|-------------|-------|--------|-------|
| | MIN | MAX | MIN | MAX |
| A | 7.000 | BSC | 0.276 | BSC |
| A1 | 3.500 | BSC | 0.138 | BSC |
| B | 7.000 | BSC | 0.276 | BSC |
| B1 | 3.500 | BSC | 0.138 | BSC |
| C | 1.400 | 1.600 | 0.055 | 0.063 |
| D | 0.300 | 0.450 | 0.012 | 0.018 |
| E | 1.350 | 1.450 | 0.053 | 0.057 |
| F | 0.300 | 0.400 | 0.012 | 0.016 |
| G | 0.800 | BSC | 0.031 | BSC |
| H | 0.050 | 0.150 | 0.002 | 0.006 |
| J | 0.090 | 0.200 | 0.004 | 0.008 |
| K | 0.450 | 0.750 | 0.018 | 0.030 |
| M | 12° | REF | 12° | REF |
| N | 0.090 | 0.160 | 0.004 | 0.006 |
| P | 0.400 | BSC | 0.016 | BSC |
| Q | 1° | 5° | 1° | 5° |
| R | 0.150 | 0.250 | 0.006 | 0.010 |
| S | 9.000 | BSC | 0.354 | BSC |
| S1 | 4.500 | BSC | 0.177 | BSC |
| V | 9.000 | BSC | 0.354 | BSC |
| V1 | 4.500 | BSC | 0.177 | BSC |
| W | 0.200 | REF | 0.008 | REF |
| X | 1.000 | REF | 0.039 | REF |

MC10EP105, MC100EP105

PACKAGE DIMENSIONS

QFN32 5*5*1 0.5 P
CASE 488AM-01
ISSUE O

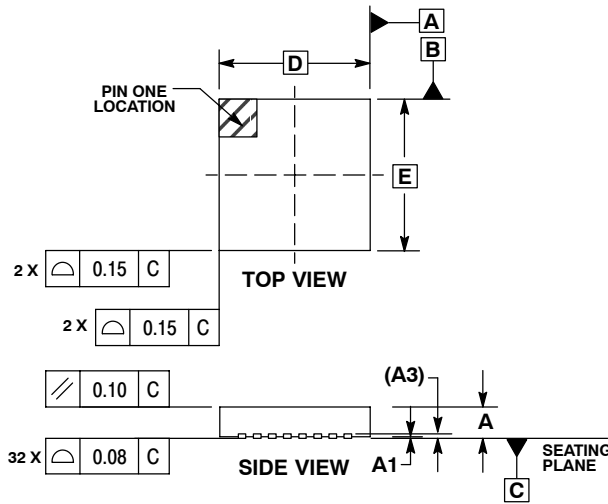

NOTES:

1. DIMENSIONS AND TOLERANCING PER ASME Y14.5M, 1994.
2. CONTROLLING DIMENSION: MILLIMETERS.
3. DIMENSION b APPLIES TO PLATED TERMINAL AND IS MEASURED BETWEEN 0.25 AND 0.30 MM TERMINAL
4. COPLANARITY APPLIES TO THE EXPOSED PAD AS WELL AS THE TERMINALS.

| DIM | MILLIMETERS | | |
|-----|-------------|-------|-------|
| | MIN | NOM | MAX |
| A | 0.800 | 0.900 | 1.000 |
| A1 | 0.000 | 0.025 | 0.050 |
| A3 | 0.200 REF | | |
| b | 0.180 | 0.250 | 0.300 |
| D | 5.00 BSC | | |
| D2 | 2.950 | 3.100 | 3.250 |
| E | 5.00 BSC | | |
| E2 | 2.950 | 3.100 | 3.250 |
| e | 0.500 BSC | | |
| K | 0.200 | --- | --- |
| L | 0.300 | 0.400 | 0.500 |

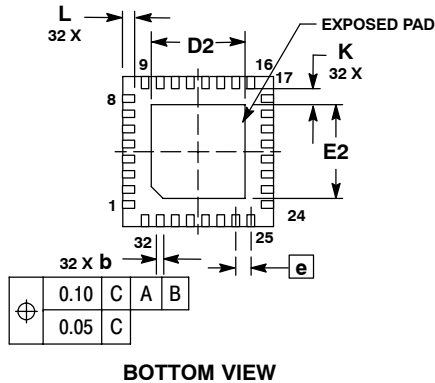

SOLDERING FOOTPRINT*

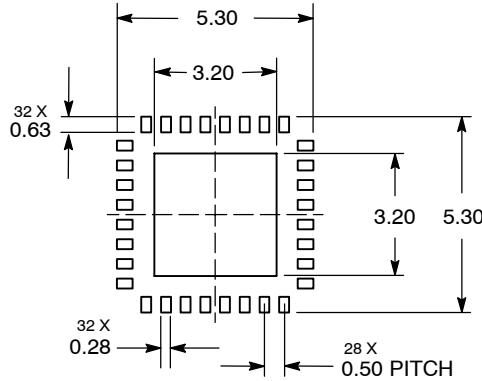

*For additional information on our Pb-Free strategy and soldering details, please download the ON Semiconductor Soldering and Mounting Techniques Reference Manual, SOLDERRM/D.

ECLinPS is a trademark of Semiconductor Components Industries, LLC (SCILLC).

ON Semiconductor and are registered trademarks of Semiconductor Components Industries, LLC (SCILLC). SCILLC reserves the right to make changes without further notice to any products herein. SCILLC makes no warranty, representation or guarantee regarding the suitability of its products for any particular purpose, nor does SCILLC assume any liability arising out of the application or use of any product or circuit, and specifically disclaims any and all liability, including without limitation special, consequential or incidental damages. "Typical" parameters which may be provided in SCILLC data sheets and/or specifications can and do vary in different applications and actual performance may vary over time. All operating parameters, including "Typicals" must be validated for each customer application by customer's technical experts. SCILLC does not convey any license under its patent rights nor the rights of others. SCILLC products are not designed, intended, or authorized for use as components in systems intended for surgical implant into the body, or other applications intended to support or sustain life, or for any other application in which the failure of the SCILLC product could create a situation where personal injury or death may occur. Should Buyer purchase or use SCILLC products for any such unintended or unauthorized application, Buyer shall indemnify and hold SCILLC and its officers, employees, subsidiaries, affiliates, and distributors harmless against all claims, costs, damages, and expenses, and reasonable attorney fees arising out of, directly or indirectly, any claim of personal injury or death associated with such unintended or unauthorized use, even if such claim alleges that SCILLC was negligent regarding the design or manufacture of the part. SCILLC is an Equal Opportunity/Affirmative Action Employer. This literature is subject to all applicable copyright laws and is not for resale in any manner.

PUBLICATION ORDERING INFORMATION

LITERATURE FULFILLMENT:
Literature Distribution Center for ON Semiconductor
P.O. Box 5163, Denver, Colorado 80217 USA
Phone: 303-675-2175 or 800-344-3860 Toll Free USA/Canada
Fax: 303-675-2176 or 800-344-3867 Toll Free USA/Canada
Email: orderlit@onsemi.com

N. American Technical Support: 800-282-9855 Toll Free USA/Canada
Europe, Middle East and Africa Technical Support:
Phone: 421 33 790 2910
Japan Customer Focus Center
Phone: 81-3-5773-3850

ON Semiconductor Website: www.onsemi.com
Order Literature: <http://www.onsemi.com/orderlit>

For additional information, please contact your local Sales Representative



Компания «ЭлектроПласт» предлагает заключение долгосрочных отношений при поставках импортных электронных компонентов на взаимовыгодных условиях!

Наши преимущества:

- Оперативные поставки широкого спектра электронных компонентов отечественного и импортного производства напрямую от производителей и с крупнейших мировых складов;
- Поставка более 17-ти миллионов наименований электронных компонентов;
- Поставка сложных, дефицитных, либо снятых с производства позиций;
- Оперативные сроки поставки под заказ (от 5 рабочих дней);
- Экспресс доставка в любую точку России;
- Техническая поддержка проекта, помощь в подборе аналогов, поставка прототипов;
- Система менеджмента качества сертифицирована по Международному стандарту ISO 9001;
- Лицензия ФСБ на осуществление работ с использованием сведений, составляющих государственную тайну;
- Поставка специализированных компонентов (Xilinx, Altera, Analog Devices, Intersil, Interpoint, Microsemi, Aeroflex, Peregrine, Syfer, Eurofarad, Texas Instrument, Miteq, Cobham, E2V, MA-COM, Hittite, Mini-Circuits, General Dynamics и др.);

Помимо этого, одним из направлений компании «ЭлектроПласт» является направление «Источники питания». Мы предлагаем Вам помощь Конструкторского отдела:

- Подбор оптимального решения, техническое обоснование при выборе компонента;
- Подбор аналогов;
- Консультации по применению компонента;
- Поставка образцов и прототипов;
- Техническая поддержка проекта;
- Защита от снятия компонента с производства.



Как с нами связаться

Телефон: 8 (812) 309 58 32 (многоканальный)

Факс: 8 (812) 320-02-42

Электронная почта: org@eplast1.ru

Адрес: 198099, г. Санкт-Петербург, ул. Калинина, дом 2, корпус 4, литера А.