

Product Specification

25G SFPwire® SFP28 Active Optical Cable

FCCG125SD1Cxx

PRODUCT FEATURES

- Hot-pluggable SFP28 cable ends
- Supports 25.7813 Gb/s bit rate
- Connectivity Diagnostics®
- SFI limiting interface
- Input equalization and output emphasis controls
- Single 3.3V power supply
- Low power dissipation
- 0°C to 70°C Temperature range
- Rigid pull-tab with LED light

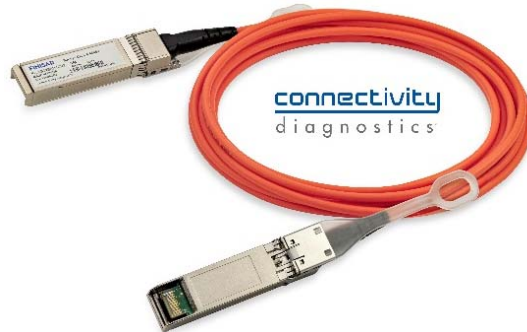

APPLICATIONS

- 25G Ethernet for Intra- and Inter-Rack datacenter interconnection

Finisar 25G SFPwire®, FCCG125SD1Cxx, are SFP28 Active Optical Cables designed for use in 25G Ethernet links. Finisar 25G SFPwire® are equipped with Connectivity Diagnostics®, a Finisar’s technology solution enabling real-time performance monitoring and troubleshooting. The electrical interface of Finisar 25G SFPwire® is compliant with SFF-8431^[1], and the receiver side is limiting.

Finisar 25G SFPwire® provides non-adaptive input equalization and output emphasis controls as per SFF-8472^[2]. The mechanical specifications of the 25G SFPwire® SFP28 ends are compatible with SFF-8432^[3].

The 25G SFPwire® are RoHS compliant per Directive 2011/65/EU^[4,5].

PRODUCT SELECTION

FCCG125SD1Cxx	Cable Length Options (Orange Jacket Cables)	
	xx = Z5 → 0.5m	xx = 05 → 5m
	xx = 01 → 1.0m	xx = 07 → 7m
	xx = A5 → 1.5m	xx = 09 → 9m
	xx = 02 → 2.0m	xx = 10 → 10m
	xx = B5 → 2.5m	xx = 15 → 15m
	xx = 03 → 3.0m	xx = 20 → 20m
	xx = C5 → 3.5m	xx = 30 → 30m

Please contact Finisar for Aqua-color jacket or custom length options.

I. Pin Descriptions

Pin	Symbol	Name/Description	Ref.
1	V _{EET}	Transmitter Ground (Common with Receiver Ground)	1
2	T _{FAULT}	Transmitter Fault.	2,3
3	T _{DIS}	Transmitter Disable. Laser output disabled on high or open.	4
4	SDA	2-wire Serial Interface Data Line	2
5	SCL	2-wire Serial Interface Clock Line	2
6	MOD_ABS	Module Absent. Grounded within the module	5
7	RS0	No connection required	
8	RX_LOS	Loss of Signal indication. Logic 0 indicates normal operation.	6
9	RS1	No connection required	
10	V _{EER}	Receiver Ground (Common with Transmitter Ground)	1
11	V _{EER}	Receiver Ground (Common with Transmitter Ground)	1
12	RD-	Receiver Inverted DATA out. AC Coupled	
13	RD+	Receiver Non-inverted DATA out. AC Coupled	
14	V _{EER}	Receiver Ground (Common with Transmitter Ground)	1
15	V _{CCR}	Receiver Power Supply	7
16	V _{CCT}	Transmitter Power Supply	7
17	V _{EET}	Transmitter Ground (Common with Receiver Ground)	1
18	TD+	Transmitter Non-Inverted DATA in. AC Coupled.	
19	TD-	Transmitter Inverted DATA in. AC Coupled.	
20	V _{EET}	Transmitter Ground (Common with Receiver Ground)	1

Notes:

1. Circuit ground is internally isolated from chassis ground.
2. Open collector/drain output, which should be pulled up with a 4.7k – 10k Ohms resistor on the host board if intended for use. Pull up voltage should be between 2.0V to V_{cc} + 0.3V.
3. A high output indicates a transmitter fault caused by either the TX bias current or the TX output power exceeding the preset alarm thresholds. A low output indicates normal operation. In the low state, the output is pulled to <0.8V.
4. Laser output disabled on T_{DIS} >2.0V or open, enabled on T_{DIS} <0.8V.
5. Internally pulled down per SFF-8431 Rev 4.1.
6. LOS is open collector output. Should be pulled up with 4.7k – 10kΩ on host board to a voltage between 2.0V and 3.6V. Logic 0 indicates normal operation; logic 1 indicates loss of signal.
7. Internally connected.

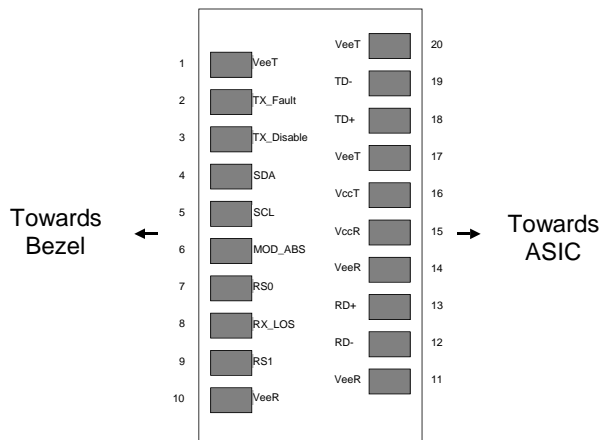

Figure 1. Diagram of Host Board Connector Block Pin Numbers and Names.

II. Absolute Maximum Ratings

Exceeding the limits below may damage the active optical cable permanently.

Parameter	Symbol	Min	Typ	Max	Unit	Ref.
Maximum Supply Voltage	V _{CC}	-0.5		4.0	V	
Storage Temperature	T _S	-5		75	°C	1
Case Operating Temperature	T _A	0		70	°C	
Relative Humidity	RH	0		85	%	2

Notes:

- Assumes no mechanical load force on the unit. Ensuring no mechanical load force requires a cable bend radius of >105 mm within 100 mm of either cable and SFP+ end and >60 mm on the rest of the cable. Cable is rated for the storage temperature range is -20 to 75°C.

Non-condensing.

III. Electrical Characteristics (each cable end, T_{OP} = 0 to 70 °C, V_{CC} = 3.14 to 3.46 Volts)

Parameter	Symbol	Min	Typ	Max	Unit	Ref.
Supply Voltage	V _{CC}	3.14		3.46	V	
Supply Current	I _{CC}			310	mA	
Transmitter						
Input differential impedance	R _{in}		100		Ω	1
Differential data input swing	V _{in,pp}	180		700	mV	
Transmit Disable Voltage	V _D	2		V _{CC}	V	
Transmit Enable Voltage	V _{EN}	V _{EE}		V _{EE} + 0.8	V	
Receiver						
Differential data output swing	V _{out,pp}	300		850	mV	2
Data output rise time, fall time	t _r			28	ps	3
LOS Fault	V _{LOS fault}	2		V _{CCHOST}	V	4
LOS Normal	V _{LOS norm}	V _{EE}		V _{EE} +0.8	V	4
Power Supply Noise Tolerance	V _{CC} T/V _{CC} R	Per SFF-8431 Rev 4.1			mVpp	5

Notes:

- Connected directly to TX data input pins. AC coupling from pins into laser driver IC.
- Into 100Ω differential termination.
- 20 – 80% . Measured with Module Compliance Test Board and OMA test pattern. Use of four 1's and four 0's in sequence in the PRBS⁹ is an acceptable alternative^[1].
- LOS is an open collector output. Should be pulled up with 4.7kΩ – 10kΩ on the host board. Normal operation is logic 0; loss of signal is logic 1. Maximum pull-up voltage is 5.5V.
- Testing methodology per [1].

IV. Input Equalization and Output Emphasis Controls

Finisar FCCG125SD1Cxx provide non-adaptive input equalization and output emphasis controls, allowing the host to select pre-set levels of optimization of the electrical high-speed signals of the transceiver's transmitter input and receiver output, via the 2-wire communication, as defined in the SFF-8472^[2].

V. General Specifications

Parameter	Symbol	Min	Typ	Max	Units	Ref.
Bit Rate	BR		25.78125		Gb/s	
Bit Error Ratio	BER			10 ⁻⁸		1

Notes: 1. Pre-FEC, tested with a PRBS 2³¹ – 1.

VI. Connectivity Diagnostics® Technology

Finisar FCCG125SD1Cxx are equipped with Connectivity Diagnostics®, which combines the pull-tabs' LED lights with the out-of-band signaling between the transceivers at the two ends of the AOC. Three features are currently implemented:



Helps locate the other end of the AOC. Manually pushing-in either pull tab will light up their LED lights on both ends.



Reports the health status of the AOC. Any Digital Diagnostic Monitoring warning/alarm events, transmitter's fault or receiver's loss of signal, will light up the pull-tab LED lights of both ends.



Allows the host to control the AOC pull-tabs' LED lights. Writing a command via the 2-wire communication interface of the near-end AOC transceiver will light up the pull-tabs' LED lights of both ends.

A detailed description of Connectivity Diagnostics® is provided in Finisar's Application Note AN-2158^[6].

VII. Environmental Specifications

The following table shows the operating temperature range of the FCCG125SD1Cxx:

Parameter	Symbol	Min	Typ	Max	Units	Ref.
Case Operating Temperature	T _{op}	0		70	°C	

VIII. Regulatory Compliance

The FCCG125SD1Cxx SFPwire®, which contains laser devices, is a Class 1 laser product and complies with 21CFR 1040.10 and 1040.11 except for deviations pursuant to Laser Notice No. 50, dated June 24, 2007, and it complies with EN(IEC) 60825 Edition 1.2 regulations. The 25G SFPwire® is RoHS compliant per Directive 2011/65/EU^[4,5].

Copies of certificates are available at Finisar Corporation upon request.

VIX. Mechanical Specifications

The FCCG125SD1Cxx SFPwire SFP28 cable ends are compatible with the SFF-8432 specifications and provide a rigid pull tab whose color is opaque, when the embedded LED light is not lit up, or amber, when illuminated.

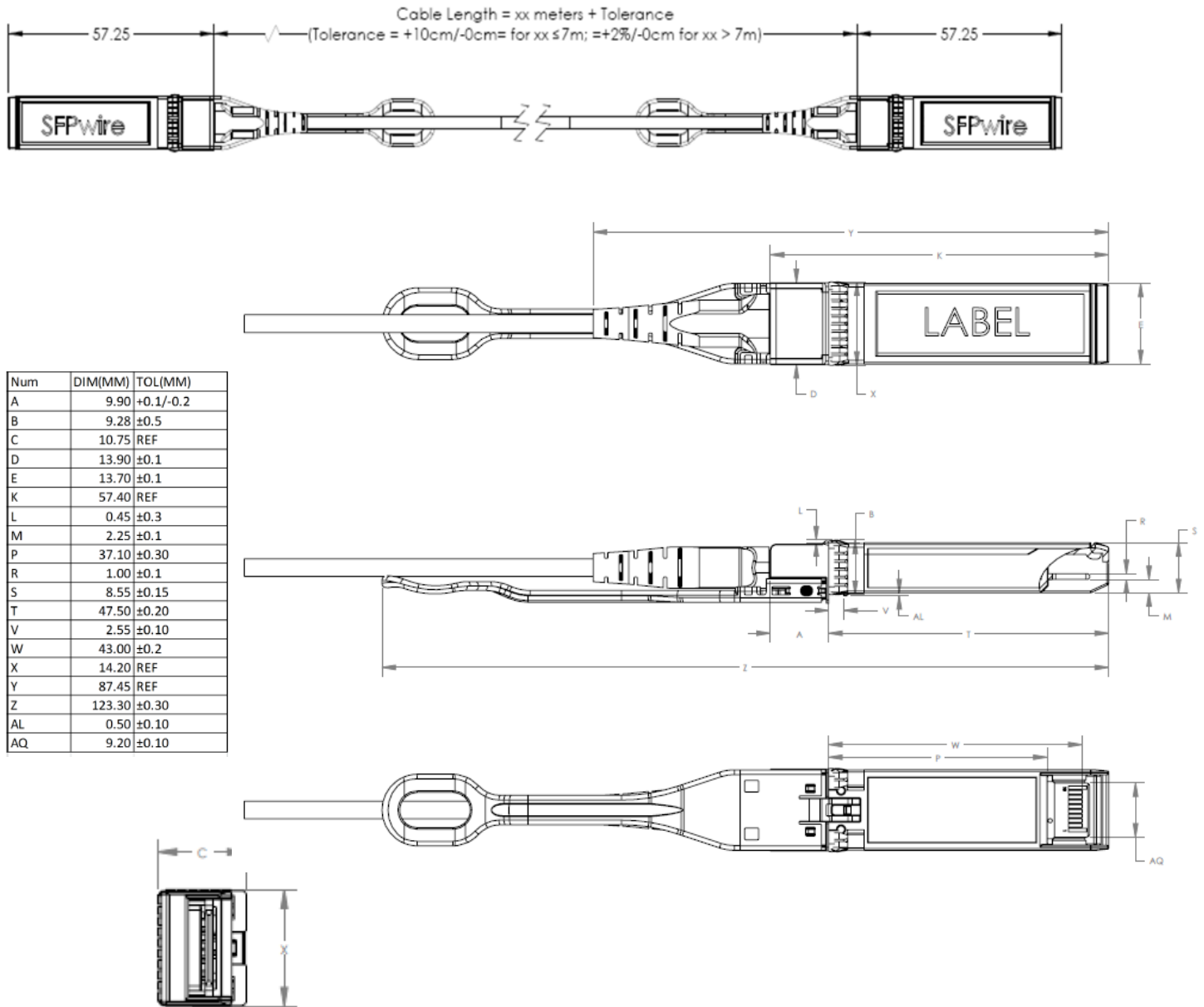

Figure 2. FCCG125SD1Cxx Mechanical Dimensions.

FCCG125SD1Cxx SFPwire® cable details

Description	Min	Typ	Max	Units	Notes
Jacket Material	PVC				PVC
Jacket Color	Orange				Aqua available upon request
Flammability Rating	OFNR				Plenum Cable option available upon request
Outer Diameter	2.8	3.0	3.2	mm	
Tensile Load (Short Term)			200	N	
Tensile Load (Long Term)			100	N	
Crush Resistance	10			N/mm	FOTP-41
Impact Resistance	0.5			N·m	FOTP-25
Flexing	300			Cycles	FOTP-104
Twist Bend					Exceeds FOTP-85
Cable to SFP+ Plug Connection			90	Newtons	
Bend Radius (Short Term)	25			mm	
Bend Radius (Long Term)	30			mm	
Durability	100			Cycle Min	

X. PCB Layout and Bezel Recommendations

- Datum and Basic Dimension Established by Customer
- Plates and Vias are Chassis Ground, 11 Places
- Through Holes are Unplated

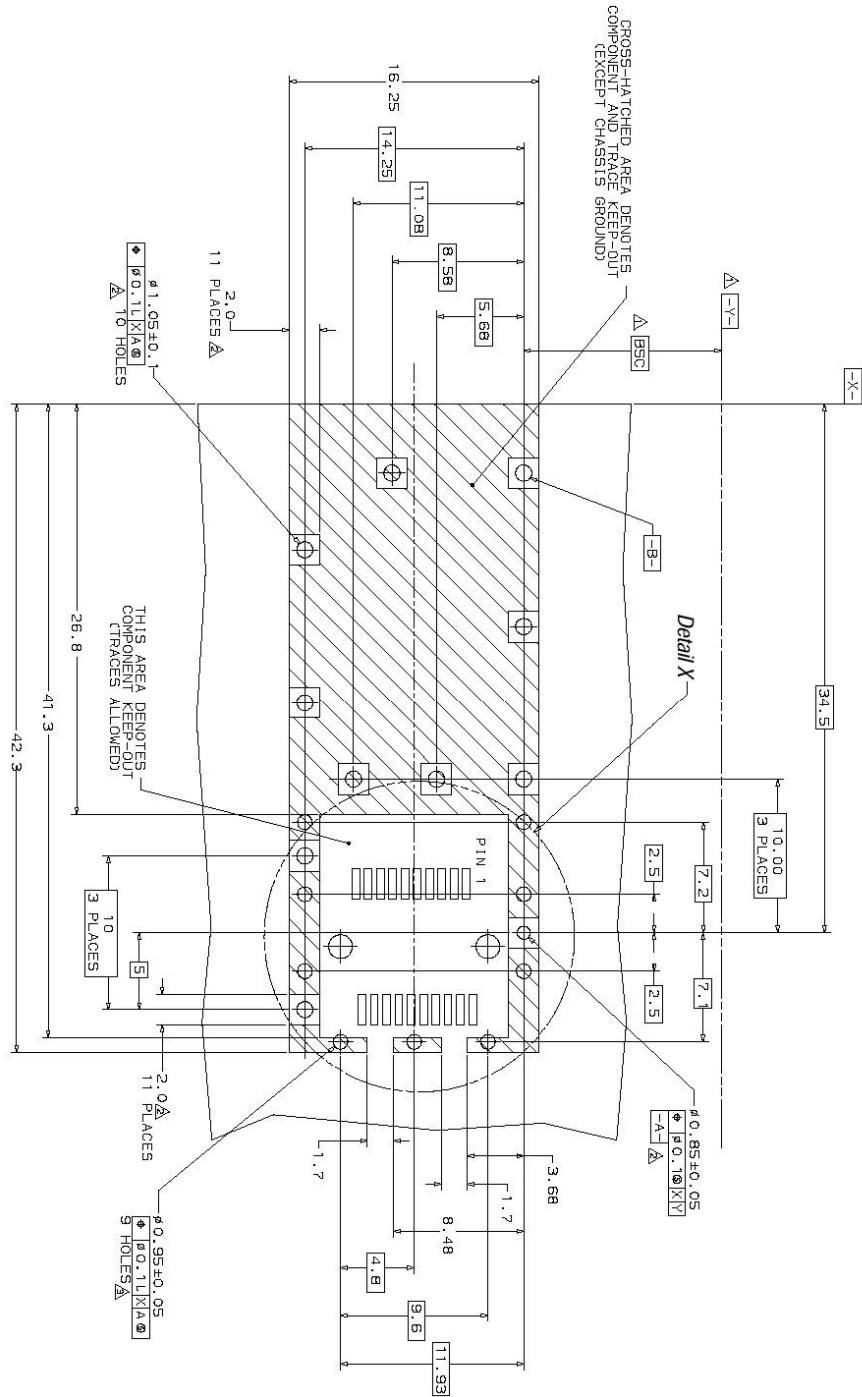
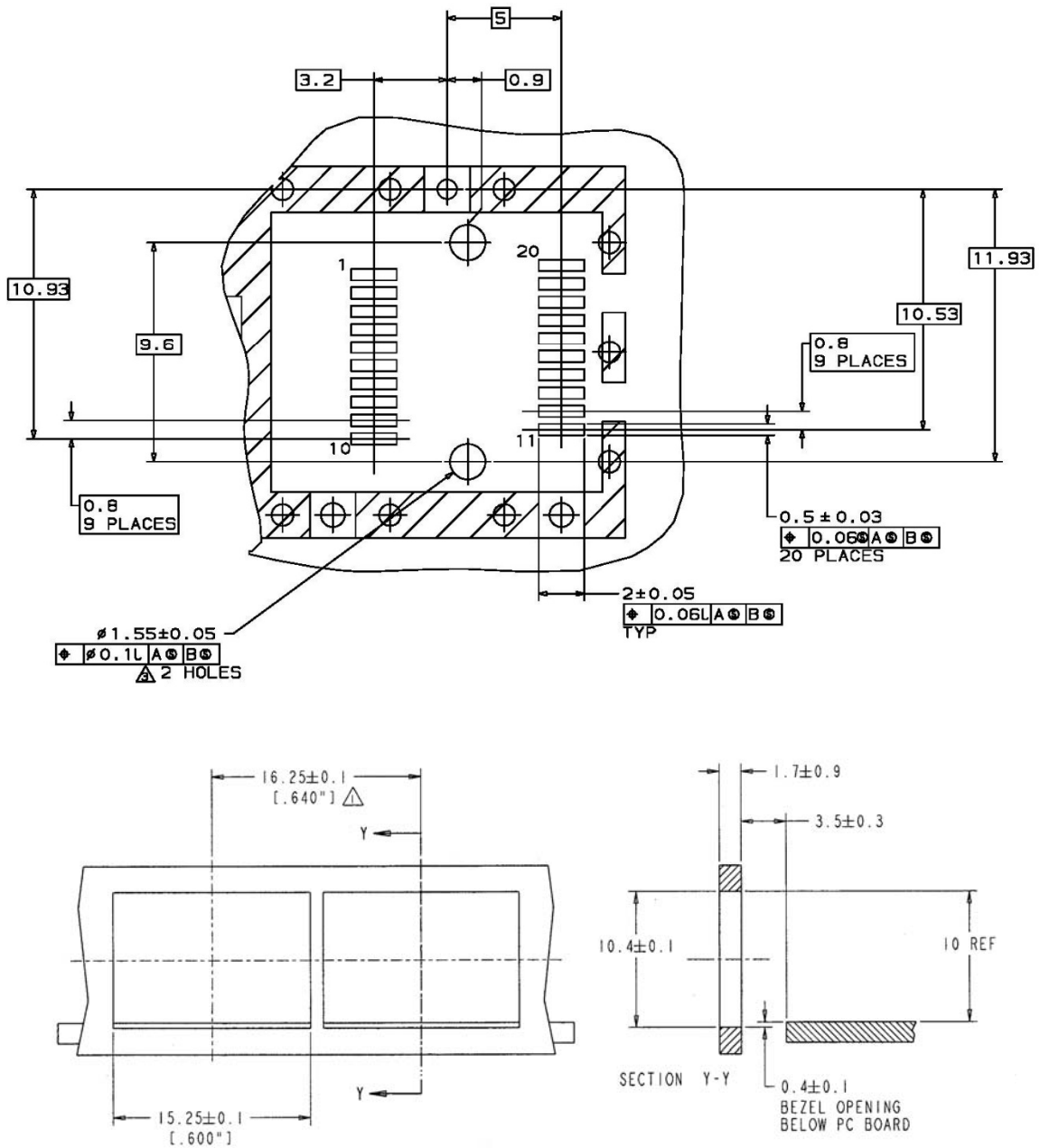

Figure 3.



- NOTES:
- 1. \triangle MINIMUM PITCH ILLUSTRATED, ENGLISH DIMENSIONS ARE FOR REFERENCE ONLY
 - 2. NOT RECOMMENDED FOR PCI EXPANSION CARD APPLICATIONS

Figure 4.

XI. Host - Active optical cable end Interface Block Diagram

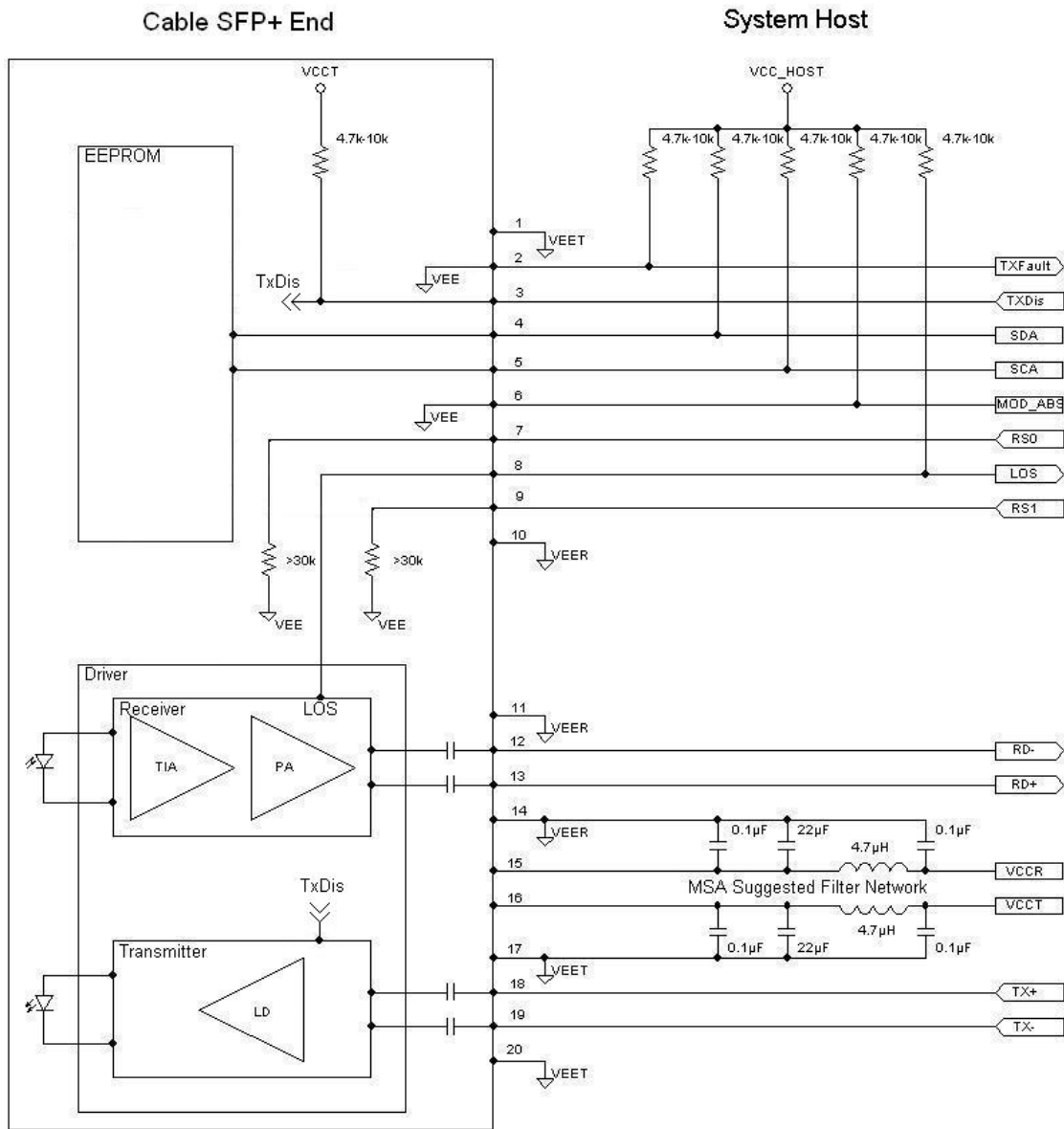

Figure 5.

XII. References

1. “Specifications for Enhanced 8.5 and 10 Gigabit Small Form Factor Pluggable Module ‘SFP+ ’”, SFF Document Number SFF-8431, Revision 4.1.
2. “Improved Pluggable Formfactor”, SFF Document Number SFF-8432, Revision 4.2, April 18, 2007.
3. Directive 2011/65/EU of the European Parliament and of the Council “on the restriction of the use of certain hazardous substances in electrical and electronic equipment”. Certain products may use one or more exemption as allowed by the directive.
4. “Application Note AN-2038: Finisar Implementation of RoHS Compliant Transceivers”, Finisar Corporation, January 21, 2005.
5. “Diagnostic Monitoring Interface for Optical Transceivers”, SFF Document Number SFF-8472, revision 12.2, November 21, 2014.
6. “Application Note AN-2158: Finisar’s Connectivity Diagnostics® for Active Optical Cables” Finisar Corporation, rev. C1, June 2018.

XIII. For More Information

Finisar Corporation
1389 Moffett Park Drive
Sunnyvale, CA 94089-1133
Tel. 1-408-548-1000
Fax 1-408-541-6138
sales@finisar.com
www.finisar.com



Компания «ЭлектроПласт» предлагает заключение долгосрочных отношений при поставках импортных электронных компонентов на взаимовыгодных условиях!

Наши преимущества:

- Оперативные поставки широкого спектра электронных компонентов отечественного и импортного производства напрямую от производителей и с крупнейших мировых складов;
- Поставка более 17-ти миллионов наименований электронных компонентов;
- Поставка сложных, дефицитных, либо снятых с производства позиций;
- Оперативные сроки поставки под заказ (от 5 рабочих дней);
- Экспресс доставка в любую точку России;
- Техническая поддержка проекта, помощь в подборе аналогов, поставка прототипов;
- Система менеджмента качества сертифицирована по Международному стандарту ISO 9001;
- Лицензия ФСБ на осуществление работ с использованием сведений, составляющих государственную тайну;
- Поставка специализированных компонентов (Xilinx, Altera, Analog Devices, Intersil, Interpoint, Microsemi, Aeroflex, Peregrine, Syfer, Eurofarad, Texas Instrument, Miteq, Cobham, E2V, MA-COM, Hittite, Mini-Circuits, General Dynamics и др.);

Помимо этого, одним из направлений компании «ЭлектроПласт» является направление «Источники питания». Мы предлагаем Вам помощь Конструкторского отдела:

- Подбор оптимального решения, техническое обоснование при выборе компонента;
- Подбор аналогов;
- Консультации по применению компонента;
- Поставка образцов и прототипов;
- Техническая поддержка проекта;
- Защита от снятия компонента с производства.



Как с нами связаться

Телефон: 8 (812) 309 58 32 (многоканальный)

Факс: 8 (812) 320-02-42

Электронная почта: org@eplast1.ru

Адрес: 198099, г. Санкт-Петербург, ул. Калинина, дом 2, корпус 4, литера А.