



VINCULUM

BINDING USB TECHNOLOGIES

Future Technology Devices International Ltd.

V2DIP1-48

VNC2-48 Development Module

Datasheet

Document Reference No.: FT_000236

Version 1.0

Issue Date: 2010-04-15

Future Technology Devices International Ltd (FTDI)

Unit 1, 2 Seaward Place, Centurion Business Park, Glasgow, G41 1HH, United Kingdom

Tel.: +44 (0) 141 429 2777 Fax: + 44 (0) 141 429 2758

E-Mail (Support): support1@ftdichip.com

Web: <http://www.vinculum.com>

Neither the whole nor any part of the information contained in, or the product described in this manual, may be adapted or reproduced in any material or electronic form without the prior written consent of the copyright holder. This product and its documentation are supplied on an as-is basis and no warranty as to their suitability for any particular purpose is either made or implied. Future Technology Devices International Ltd will not accept any claim for damages howsoever arising as a result of use or failure of this product. Your statutory rights are not affected. This product or any variant of it is not intended for use in any medical appliance, device or system in which the failure of the product might reasonably be expected to result in personal injury. This document provides preliminary information that may be subject to change without notice. No freedom to use patents or other intellectual property rights is implied by the publication of this document. Future Technology Devices International Ltd, Unit 1, 2 Seaward Place, Centurion Business Park, Glasgow, G41 1HH, United Kingdom. Scotland Registered Number: SC136640

Copyright © 2010 Future Technology Devices International Limited

1 Introduction

V2DIP1-48 module is designed to allow rapid development of designs using the VNC2-48Q IC. The V2DIP1-48 is supplied as a PCB designed to fit into a 24 pin 0.6" wide 0.1" pitch DIP socket. The module provides access to the UART, parallel FIFO, and SPI interface pins of the VNC2-48Q device, via onboard header pins. The module has a single USB ports which is accessible via the onboard type A USB connector.

V2DIP1 48 photo awaiting

Figure 1.1- V2DIP1 48

The VNC2 is the second of FTDI's Vinculum family of Embedded dual USB host controller devices. The VNC2 device provides USB Host interfacing capability for a variety of different USB device classes including support for BOMS (bulk only mass storage), Printer, HID (human interface devices). For mass storage devices such as USB Flash drives, VNC2 also transparently handles the FAT file structure.

Communication with non USB devices such as a low cost microcontroller is accomplished via either UART, SPI or parallel FIFO interfaces. The VNC2 provides a new cost effective solution for providing USB Host capability into products that previously did not have the hardware resources available.

The VNC2 supports the capability to enable customers to develop custom firmware using the Vinculum II development software tool suite. The development tools support compiler, linker and debugger tools complete within an integrated development environment (IDE).

The Vinculum-II VNC2 family of devices are available in Pb-free (RoHS compliant) 32-lead LQFP, 32-lead QFN, 48-lead LQFP, 48-lead QFN, 64-Lead IQFP and 64-lead QFN packages.

Table of Contents

1	Introduction.....	1
2	Features	3
3	Pin Out and Signal Description	4
3.1	Module Pin Out	4
3.2	Pin Signal Description	6
3.3	I/O Configuration Using The Jumper Pin Header	8
3.4	Default Interface I/O Pin Configuration.....	9
3.5	UART Interface.....	10
3.5.1	Signal Description – UART Interface.....	10
3.6	Serial Peripheral Interface (SPI)	11
3.6.1	Signal Description - SPI Slave	11
3.6.2	Signal Description - SPI Master	11
3.7	Parallel FIFO Interface-Asynchronous Mode	12
3.7.1	Signal Description - Parallel FIFO Interface	12
3.7.2	Timing Diagram – Asynchronous FIFO Mode Read and Write Cycle	13
3.8	Parallel FIFO Interface-Synchronous Mode	14
3.8.1	Timing Diagram – Synchronous FIFO Mode Read and Write Cycle	14
3.9	Debugger Interface	16
3.9.1	Signal Description - Debugger Interface	16
4	Firmware	17
4.1	Firmware Support.....	17
4.2	Available Firmware.....	17
4.3	Firmware Upgrades	17
5	External circuit Configuration	18
5.1	Adding a second USB Port	18
6	Mechanical Dimensions	19
7	Schematic Diagram	20
8	Contact Information.....	21
	Appendix A – References	22
	Appendix B – List of Figures and Tables	23
	List of Figures.....	23
	List of Tables	23
	Appendix C – Revision History	24

2 Features

The V2DIP1 48 incorporates the following features:

- Uses FTDI's VNC2-48Q embedded USB host controller IC device
- Single USB 'A' type socket to interface with USB peripheral devices
- Connection to a second USB interface port available via module I/O pins if required.
- Jumper selectable UART, parallel FIFO or SPI MCU interfaces
- UART, parallel FIFO and SPI interfaces can be programmed to a choice of available I/O pins
- Single 5V supply input from DIL connectors or 5V supplied via USB VBUS slave interface or debugger module.
- All VNC2 signals available on 0.6" wide, 0.1" pitch DIL male connectors.
- Auxiliary 3.3 V / 200 mA power output to external logic.
- Power and traffic indicator LED's
- V2DIP1-48 is a Pb-free, RoHS complaint development module.
- Debugger interface pin available via 6 way male header which interfaces to separate debugger module.
- Firmware upgrades via UART or debugger interface.
- FOC software development supported through Vinculum software development tool suite IDE consisting integrated compiler, linker, and debugger capabilities.

3 Pin Out and Signal Description

3.1 Module Pin Out

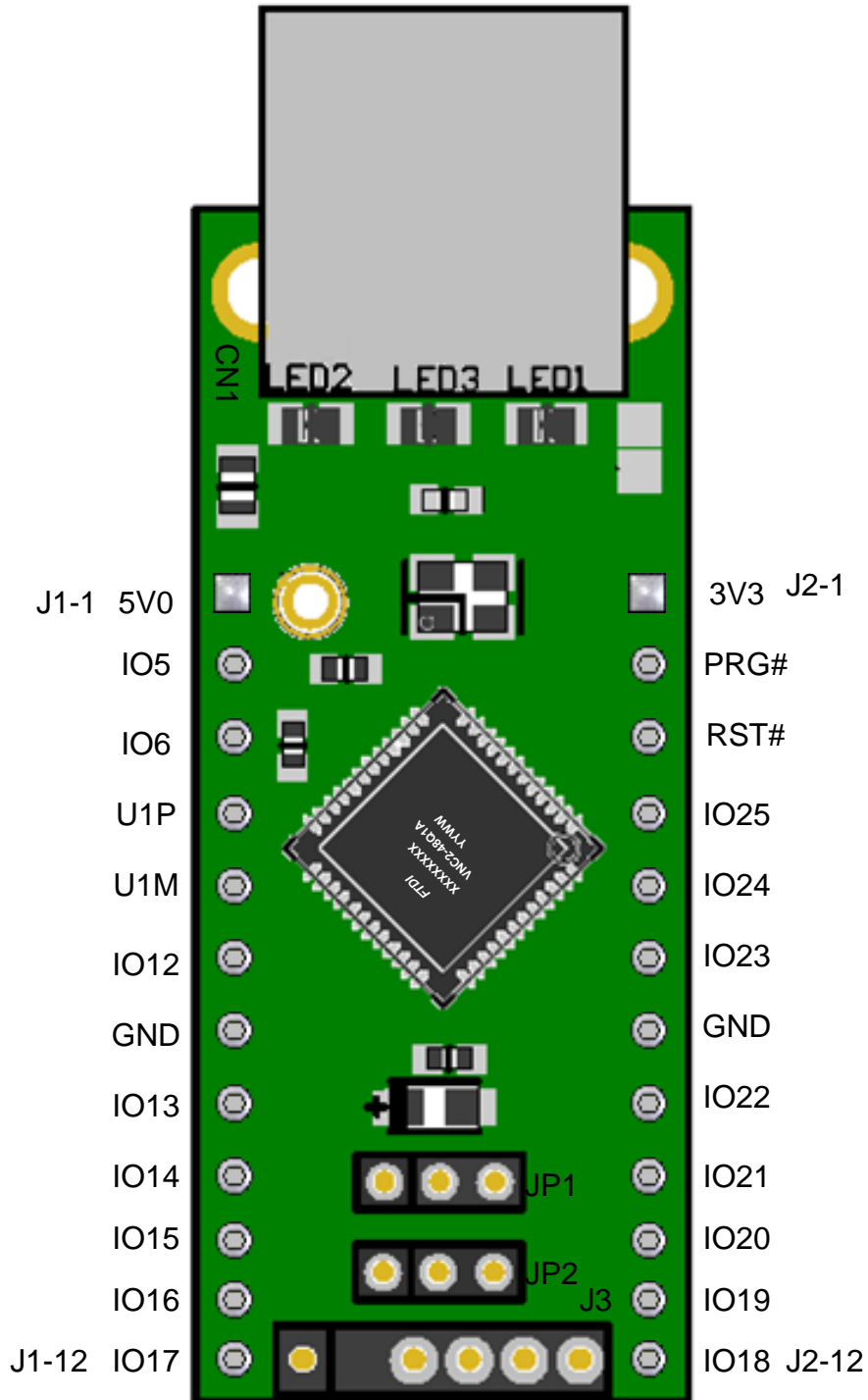

Figure 3.1 - V2DIP1 48 Module Pin Out (Top View)

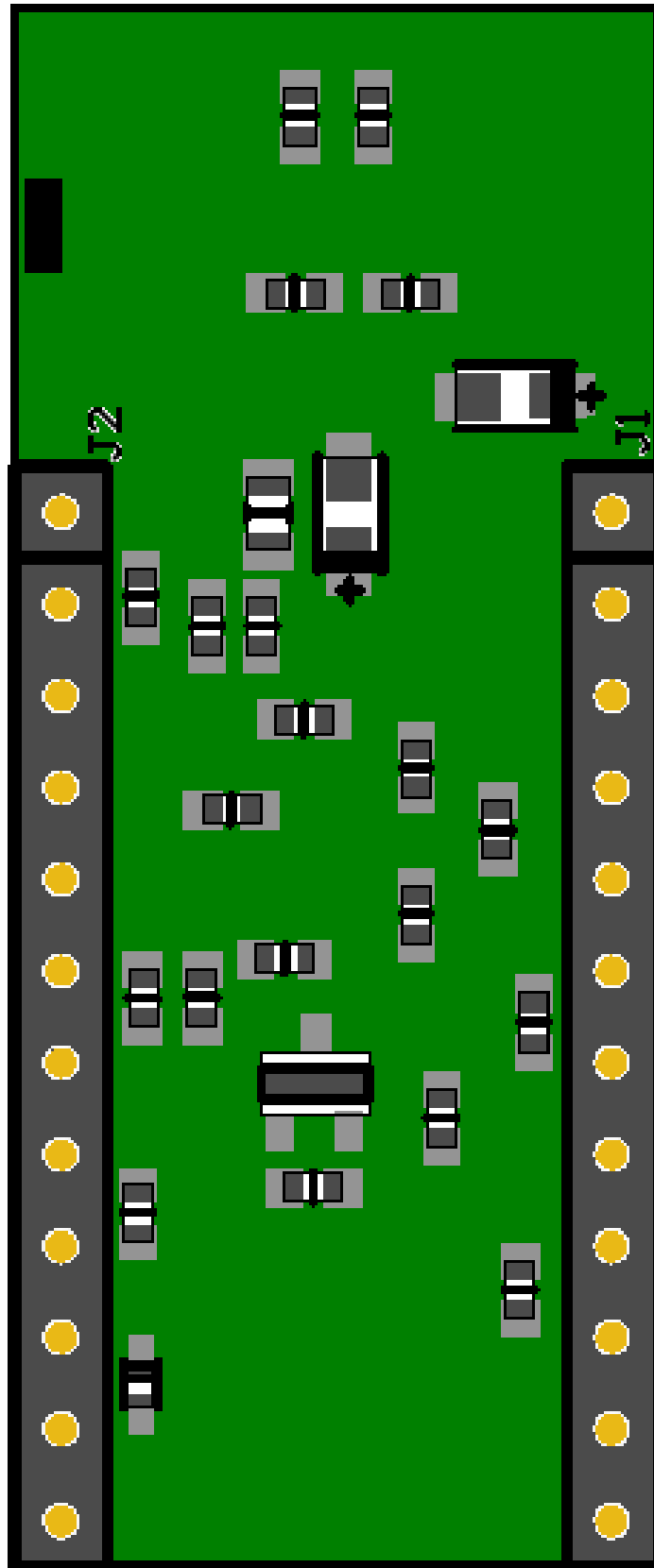

Figure 3.2 - V2DIP1 48 Module Pin Out (Bottom View)

3.2 Pin Signal Description

Pin No. (VDIP1)	Name (VDIP1)	Pin Name on PCB	Type	Description
J1-1 (1)	5V0	5V0	PWR Input	5.0V module supply pin. This pin can be used to provide the 5.0V input to the V2DIP1-48 when the V2DIP1-48 is not powered from the USB connector (VBUS) or the debugger interface. Also connected to DIL connector pins J1-2, J1-3 and J1-9 and J3-6.
J1-2 (2)	IOBUS5	IO5	Output	USB port 1 traffic activity indicator LED. This pin is hard wired to a green LED on board the PCB. It is also brought out onto this pin which allows for the possibility of bringing an additional LED traffic indicator out of the V2DIP1 board. For example, if the V2DIP1 USB connector is brought out onto an instrument front panel, an activity LED could be mounted along side it.
J1-3 (3)	IOBUS6	IO6	Output	USB port 2 traffic activity indicator LED. This pin is hard wired to a green LED on board the PCB. It is also brought out onto this pin which allows for the possibility of bringing an additional LED traffic indicator out of the V2DIP1 board. For example, if the V2DIP1 USB connector is brought out onto an instrument front panel, an activity LED could be mounted along side it.
J1-4 (4)	USBD1P	U1P	I/O	USB host / slave port 1 - USB Data Signal Plus with integrated pull up / pull down resistor. Module has on board 27 Ω USB series resistor. This pin can be brought out along with pin 5 to provide a second USB port, if required
J1-5 (5)	USBD1M	U1M	I/O	USB host / slave port 1 - USB Data Signal Minus with integrated pull up / pull down resistor. Module has on board 27 Ω USB series resistor. This pin can be brought out along with pin 4 to provide a second USB port, if required
J1-6 (6)	IOBUS12	IO12	I/O	5V safe bidirectional data / control bus bit 12
J1-7 (7)	GND	GND	PWR	Module ground supply pin
J1-8 (8)	IOBUS13	IO13	I/O	5V safe bidirectional data / control bus bit 13
J1-9 (9)	IOBUS14	IO14	I/O	5V safe bidirectional data / control bus bit 14
J1-10 (10)	IOBUS15	IO15	I/O	5V safe bidirectional data / control bus bit 15
J1-11 (11)	IOBUS16	IO16	I/O	5V safe bidirectional data / control bus bit 16
J1-12 (12)	IOBUS17	IO17	I/O	5V safe bidirectional data / control bus bit 17
J2-1 (24)	3V3	3V3	PWR	3.3V output from V2DIP1's on board 3.3V L.D.O.
J2-2 (23)	PROG#	PROG#	Input	This pin is used in combination with the RESET# pin and the UART / parallel FIFO / SPI interface to program firmware into the VNCL2.
J2-3 (22)	RESET#	RST#	Input	Can be used by an external device to reset the VNCL2. This pin can be used in combination with PROG# and the UART / parallel FIFO / SPI interface to program firmware into the VNCL2.
J2-4 (21)	IOBUS25	IO25	I/O	5V safe bidirectional data / control bus bit 25

Table 3.1 - Pin Signal Descriptions

Pin No. (VDIP1)	Name (VDIP1)	Pin Name on PCB	Type	Description
J2-5 (20)	IOBUS24	IO24	I/O	5V safe bidirectional data / control bus bit 24
J2-6 (19)	IOBUS23	IO24	I/O	5V safe bidirectional data / control bus bit 23
J2-7 (18)	GND	GND	PWR	Module ground supply pin
J2-8 (17)	IOBUS22	IO22	I/O	5V safe bidirectional data / control bus bit 22
J2-9 (16)	IOBUS21	IO21	I/O	5V safe bidirectional data / control bus bit 21
J2-10 (15)	IOBUS20	IO20	I/O	5V safe bidirectional data / control bus bit 20
J2-11 (14)	IOBUS19	IO19	I/O	5V safe bidirectional data / control bus bit 19
J2-12 (13)	IOBUS18	IO18	I/O	5V safe bidirectional data / control bus bit 18

Table 3.1 - Pin Signal Descriptions

3.3 I/O Configuration Using The Jumper Pin Header

Two three way jumper pin headers are provided to allow for simple configuration of the I/O on data and control bus pins of the 48 pin QFN Vinculum-II. This is done by a combination of pulling up or pulling down the 48 pin QFN Vinculum-II IOBUS25 (pin 46) and IOBUS26 (pin 47). The relevant portion of the V2DIP1 48 module schematic is shown in [Figure 3.3](#).

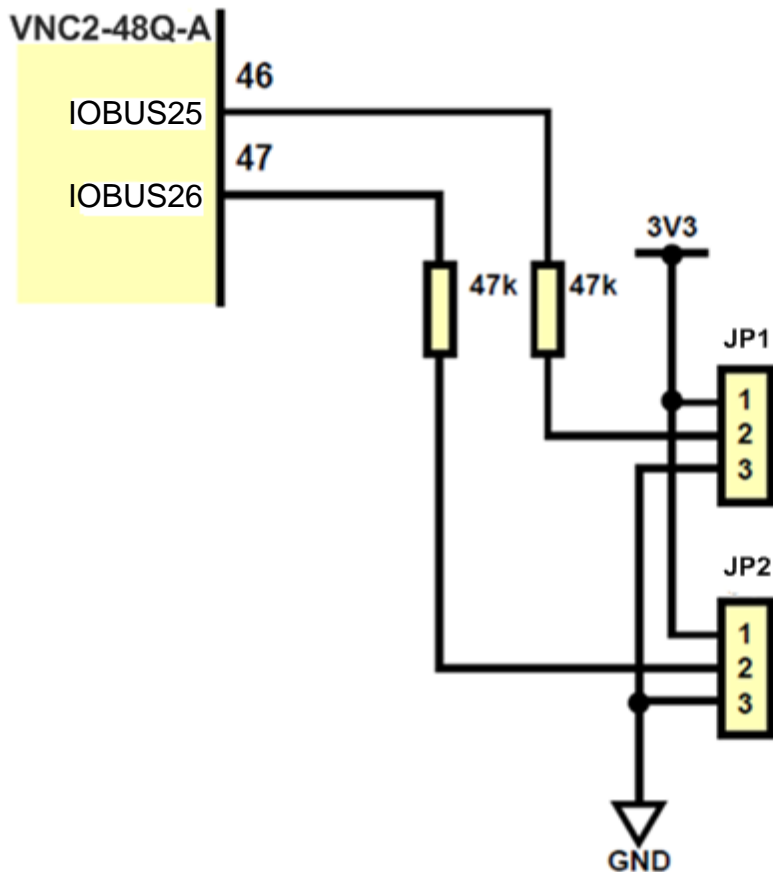

Figure 3.3 - V2DIP1 48 On-Board Jumper Pin Configuration.

IOBUS25 (VNC2-48Q pin 47)	IOBUS26 (VNC2-48Q pin 46)	I/O Mode
Pull-Up	Pull-Up	Serial UART
Pull-Up	Pull-Down	SPI
Pull-Down	Pull-Up	Parallel FIFO
Pull-Down	Pull-Down	Serial UART

Table 3.2 - V2DIP1 48 Port Selection Jumper Pins

NOTE: This is only applicable when using VNC1L compatible firmware e.g. V2DAP2. Other wise the user can set the pins for their own use.

3.4 Default Interface I/O Pin Configuration

The VNC2-48Q device is delivered without any firmware pre-loaded. As such the IOMUX will provide a default pinout as shown in **Table 3.3**

Pin No.	Name	Pin Name on PCB	Type	Data and Control Bus Configuration Options				
				UART Interface	SPI Slave Interface	SPI Master Interface	Parallel FIFO Interface	Debugger Interface
J3-1	IOBUS0	IO0	I/O	NA	NA	NA	NA	debug_if
J1-2	IOBUS5	IO5	I/O	NA	spi_s0_mosi	NA	NA	NA
J1-3	IOBUS6	IO6	I/O	NA	spi_s0_miso	NA	NA	NA
J1-6	IOBUS12	IO12	I/O	uart_txd	NA	NA	NA	NA
J1-8	IOBUS13	IO13	I/O	uart_rxd	NA	NA	NA	NA
J1-9	IOBUS14	IO14	I/O	uart_rts#	NA	NA	NA	NA
J1-10	IOBUS15	IO15	I/O	uart_cts#	NA	NA	NA	NA
J1-11	IOBUS16	IO16	I/O	uart_dtr#	NA	NA	NA	NA
J1-12	IOBUS17	IO17	I/O	uart_dsr#	NA	NA	NA	NA
J2-12	IOBUS18	IO18	I/O	uart_dcd#	NA	NA	NA	NA
J2-11	IOBUS19	IO19	I/O	uart_ri#	NA	NA	NA	NA
J2-10	IOBUS20	IO20	I/O	uart_tx_acti	NA	NA	NA	NA

Table 3.3 - Default Interface I/O Pin Configuration

3.5 UART Interface

When the data and control buses are configured in UART mode, the interface implements a standard asynchronous serial UART port with flow control. The UART can support baud rates from 300baud to 3Mbaud. The UART interface is described more fully in a Vinculum-II datasheet please refer to:- [FTDI website](#).

3.5.1 Signal Description – UART Interface

The UART signals can be programmed to a choice of I/O pin available. [Table 3.4](#) explains the available pins for each of the UART signals.

<i>Available Pins</i>	<i>Name</i>	<i>Type</i>	<i>Description</i>
J1-6, J1-11, J2-5, J2-10	uart_txd	Output	Transmit asynchronous data output
J1-2, J1-8, J1-12, J2-9	uart_rxd#	Input	Receive asynchronous data input
J1-3, J1-9, J2-12, J2-8	uart_rts#	Output	Request To Send Control Output
J1-10, J2-11, J2-6	uart_cts#	Input	Clear To Send Control Input
J1-6, J1-11, J2-5, J2-10	uart_dtr#	Output	Data Acknowledge (Data Terminal Ready Control) Output
J1-2, J1-8, J1-12, J2-9	uart_dsr#	Input	Data Request (Data Set Ready Control) Input
J1-3, J1-9, J2-12, J2-8	uart_dcd#	Input	Data Carrier Detect Control Input
J1-10, J2-11, J2-6	uart_ri#	Input	Ring Indicator Control Input. uart_ri# low can be used to resume the PC USB Host controller from suspend.
J1-6, J1-11, J2-5, J2-10	uart_tx_active	Output	Enable Transmit Data for RS485 designs. uart_tx_active may be used to signal that a transmit operation is in progress. The uart_tx_active signal will be set high one bit-time before data is transmitted and return low one bit time after the last bit of a data frame has been transmitted

Table 3.4 - Data and Control Bus Signal Mode Options – UART Interface

3.6 Serial Peripheral Interface (SPI)

The VNC2-48Q has one master module and two slave modules. These modules are described more fully in a Vinculum-II datasheet please refer to:- [FTDI website](#).

3.6.1 Signal Description - SPI Slave

The SPI Slave signals can be programmed to a choice of available I/O pins. Table 3.5 explains the available pins for each of the SPI Slave signals.

Available Pins	Name	Type	Description
J1-6, J1-11, J2-5, J2-10	spi_s0_clk spi_s1_clk	Input	Slave clock input
J1-2, J1-8, J1-12, J2-9	spi_s0_mosi spi_s1_mosi	Input/Output	Master Out Slave In Synchronous data from master to slave
J1-3, J1-9, J2-12, J2-8	spi_s0_miso spi_s1_miso	Output	Master In Slave Out Synchronous data from slave to master
J1-10, J2-11, J2-6	spi_s0_ss# spi_s1_ss#	Input	Slave chip select

Table 3.5 - Data and Control Bus Signal Mode Options – SPI Slave

3.6.2 Signal Description - SPI Master

The SPI Master signals can be programmed to a choice of available I/O pins [Table 3.6](#), shows the SPI master signals and the available pins that they can be mapped.

Available Pins	Name	Type	Description
J1-6, J1-11, J2-5, J2-10	spi_m_clk	Output	SPI master clock input
J1-2, J1-8, J1-12, J2-9	spi_m_mosi	Output	Master Out Slave In Synchronous data from master to slave
J1-3, J1-9, J2-12, J2-8	spi_m_miso	Input	Master In Slave Out Synchronous data from slave to master
J1-10, J2-11, J2-6	spi_m_cs_0#	Output	Active low slave select 0 from master to slave 0
J1-6, J1-11, J2-5, J2-10	spi_m_cs_1#	Output	Active low slave select 1 from master to slave 1

Table 3.6 - Data and Control Bus Signal Mode Options – SPI Master

3.7 Parallel FIFO Interface-Asynchronous Mode

The Parallel FIFO Asynchronous mode is functionally the same as the Parallel FIFO Interface present in VDIP1 has an eight bit parallel data bus, individual read and write strobes and two hardware flow control signals.

3.7.1 Signal Description - Parallel FIFO Interface

The Parallel FIFO Interface signals can be programmed to a choice of available I/O pins. [Table 3.7](#), shows the Parallel FIFO Interface signals and the pins that they can be mapped.

Form
Delet

Available Pins	Name	Type	Description
J1-6, J1-11, J2-5, J2-10	fifo_data[0]	I/O	FIFO data bus Bit 0
J1-2, J1-8, J1-12, J2-9	fifo_data[1]	I/O	FIFO data bus Bit 1
J1-3, J1-9, J2-12, J2-8	fifo_data[2]	I/O	FIFO data bus Bit 2
J1-10, J2-11, J2-6	fifo_data[3]	I/O	FIFO data bus Bit 3
J1-6, J1-11, J2-5, J2-10	fifo_data[4]	I/O	FIFO data bus Bit 4
J1-2, J1-8, J1-12, J2-9	fifo_data[5]	I/O	FIFO data bus Bit 5
J1-3, J1-9, J2-12, J2-8	fifo_data[6]	I/O	FIFO data bus Bit 6
J1-10, J2-11, J2-6	fifo_data[7]	I/O	FIFO data bus Bit 7
J1-6, J1-11, J2-5, J2-10	fifo_rxf#	Output	When high, do not read data from the FIFO. When low, there is data available in the FIFO which can be read by strobing RD# low, then high.
J1-2, J1-8, J1-12, J2-9	fifo_txe#	Output	When high, do not write data into the FIFO. When low, data can be written into the FIFO by strobing WR high, then low.
J1-3, J1-9, J2-12, J2-8	fifo_rd#	Input	Enables the current FIFO data byte on D0...D7 when low. Fetches the next FIFO data byte (if available) from the receive FIFO buffer when RD# goes from high to low
J1-10, J2-11, J2-6	fifo_wr#	Input	Writes the data byte on the D0...D7 pins into the transmit FIFO buffer when WR goes from high to low.

Table 3.7 - Data and Control Bus Signal Mode Options – Parallel FIFO Interface

3.7.2 Timing Diagram – Asynchronous FIFO Mode Read and Write Cycle

When in Asynchronous FIFO interface mode, the timing of a read and write operation on the FIFO interface is shown in [Figure 3.4](#) and [Table 3.8](#).

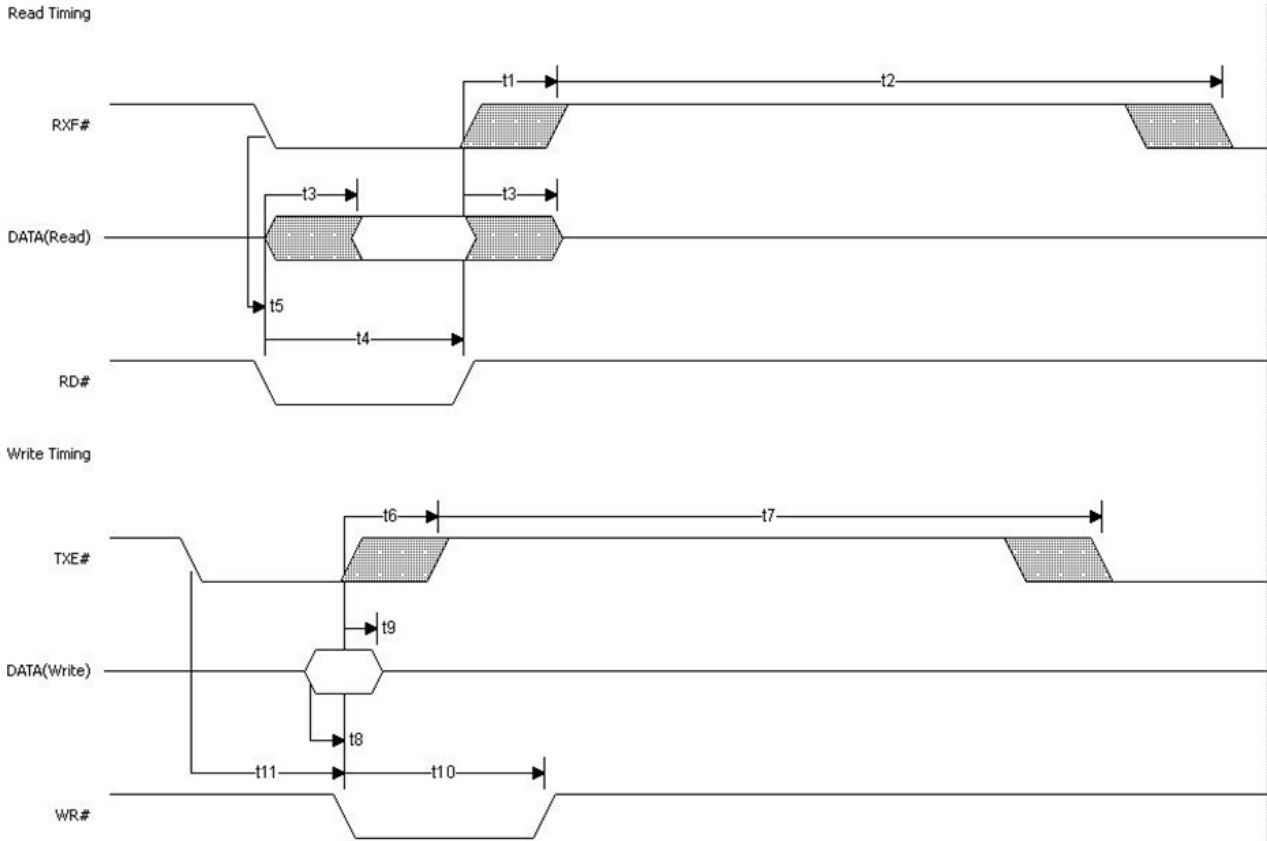

Figure 3.4 – Asynchronous FIFO Mode Read and Write Cycle.

Time	Description	Min	Max	Unit
t1	RD# inactive to RXF#	1	14	ns
t2	RXF# inactive after RD# cycle	100	-	ns
t3	RD# to Data	1	14	ns
t4	RD# active pulse width	30	-	ns
t5	RD# active after RXF#	0	-	ns
t6	WR# active to TXE# inactive	1	14	ns
t7	TXE# inactive after WR# cycle	100	-	ns
t8	DATA to TXE# active setup time	5	-	ns
t9	DATA hold time after WR# inactive	5	-	ns
t10	WR# active pulse width	30	-	ns
t11	WR# active after TXE#	0	-	ns

Table 3.8 - Asynchronous FIFO Mode Read Cycle Timing

In asynchronous mode an external device can control data transfer driving FIFO_WR# and FIFO_RD# inputs. In contrast to synchronous mode, in asynchronous mode the 245 FIFO module generates the output enable EN# signal. EN# signal is effectively the read signal RD#.

Current byte is available to be read when FIFO_RD# goes low. When FIFO_RD# goes high, FIFO_RXF# output will also go high. It will only become low again when there is another byte to read.

When FIFO_WR# goes low FIFO_TXE# flag will always go high. FIFO_TXE# goes low again only when there is still space for data to be written in to the module.

3.8 Parallel FIFO Interface-Synchronous Mode

The Parallel FIFO Synchronous mode has an eight bit data bus, individual read and write strobes, two hardware flow control signals, an output enable and a clock out.

The synchronous FIFO mode uses the parallel FIFO interface signals detailed in [Table 3.7](#), and an additional two signals detailed in [Table 3.9](#).

Available Pins	Name	Type	Description
J2-8, J2-4, J1-7, J1-14, J1-19, J2-18, J2-13	fifo_oe#	Output	FIFO Output Enable
J2-7, J1-4, J1-8, J1-16, J1-20, J2-17	fifo_clkout	Output	FIFO Output Enable

Table 3.9 - Data and Control Bus Signal Mode Options – Synchronous FIFO mode

3.8.1 Timing Diagram – Synchronous FIFO Mode Read and Write Cycle

When in Synchronous FIFO interface mode, the timing of a read and write operation on the FIFO interface are shown in [Figure 3.5](#), and [Table 3.10](#).

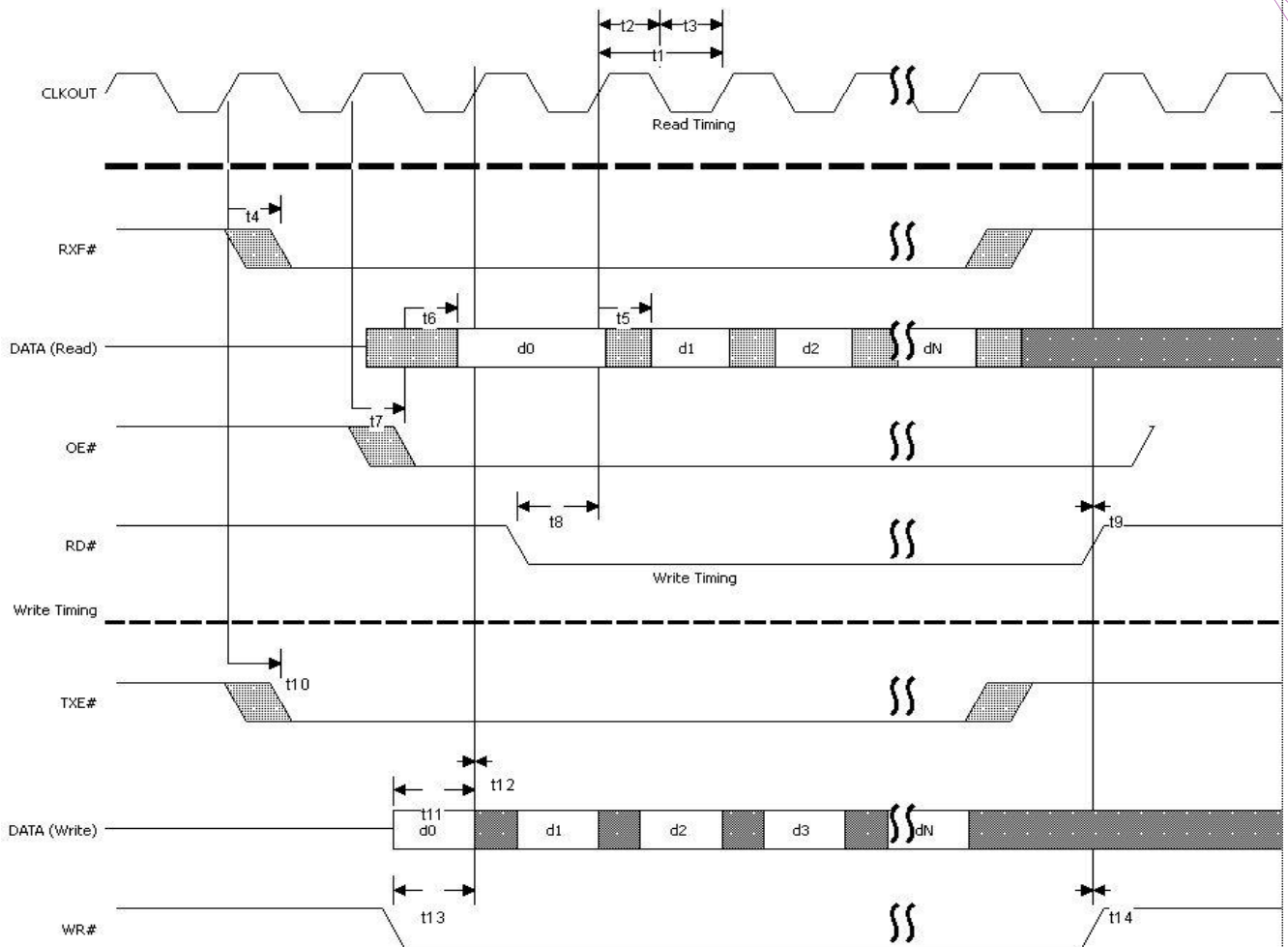

Figure 3.5 - Synchronous FIFO Mode Read and Write Cycle

<i>Time</i>	<i>Description</i>	<i>Min</i>	<i>Typical</i>	<i>Max</i>	<i>Unit</i>
t1	CLKOUT period	-	20.83	-	ns
t2	CLKOUT high period	9.38	10.42	11.46	ns
t3	CLKOUT low period	9.38	10.42	11.46	ns
t4	CLKOUT to RXF#	1	-	7.83	ns
t5	CLKOUT to read DATA valid	1	-	7.83	ns
t6	OE# to read DATA valid	1	-	7.83	ns
t7	CLKOUT to OE#	1	-	7.83	ns
t8	RD# setup time	12	-	-	ns
t9	RD# hold time	0	-	-	ns
t10	CLKOUT TO TXE#	1	-	-	ns
t11	Write DATA setup time	12	-	-	ns
t12	Write DATA hold time	0	-	-	ns
t13	WR# setup time	12	-	-	ns
t14	WR# hold time	0	-	-	ns

Table 3.10 - Synchronous FIFO Mode Read and Write Cycle Timing

In synchronous mode data can be transmitted to and from the FIFO module on each clock edge. An external device synchronises to the CLKOUT output and it also has access to the output enable OE# input to control data flow. An external device should drive output enable OE# low before pulling RD# line down.

When bursts of data are to be read from the module RD# should be kept low. RXF# remains low when there is still data to be read. Similarly when bursts of data are to be written to the module WR# should be kept low. TXE# remains low when there is still space available for the data to be written

3.9 Debugger Interface

The purpose of the debugger interface is to provide access to the VNC2 silicon/firmware debugger. The debug interface can be accessed by connecting a debug module to the J3 connector. This debug module will give access to the debugger through a USB connection to a PC via the Integrated Development Environment (IDE). The IDE is a graphical interface to the VNC2 software development tool-chain and gives the following debug capabilities through the debugger interface:

- Flash Erase, Write and Program.
- Application debug - application code can have breakpoints, be single stepped and can be halted.
- Detailed internal debug - memory and register read/write access.

The Debugger Interface, and how to use it, is further described in the following applications Note [Vinculum-II Debug Interface Description](#)

3.9.1 Signal Description - Debugger Interface

Table 3.11 shows the signals and pins description for the debugger interface pin header J3

<i>Pin No.</i>	<i>Name</i>	<i>Name On PCB</i>	<i>Type</i>	<i>Description</i>
J3-1	IO0	DBG	I/O	Debugger Interface
J3-2	-	[Key]	-	Not connected. Used to make sure that the debug module is connected correctly.
J3-3	GND	GND	PWR	Module ground supply pin
J3-4	RESET#	RST#	Input	Can be used by an external device to reset the VNCL2. This pin is also used in combination with PROG# and the UART interface to program firmware into the VNC2.
J3-5	PROG#	PRG#	Input	This pin is used in combination with the RESET# pin and the UART interface to program firmware into the VNC2.
J3-6	5V0	VCC	PWR Input	5.0V module supply pin. This pin can be used to provide the 5.0V input to the V2DIP1-48 when the V2DIP1-48 is not powered from the USB connector (VBUS) or the debugger interface. Also connected to DIL connector pins J1-2, J1-3 and J1-9 and J3-6.

Table 3.11 - Signal Name and Description – Debugger Interface

4 Firmware

4.1 Firmware Support

V2DIP1-48 can be programmed with the customers own firmware or with pre-compiled firmware profiles to allow a designer to easily change the functionality of the chip.

4.2 Available Firmware

V2DAP firmware is currently available: USB Host for single Flash Disk and general purpose USB peripherals. Selectable UART, FIFO or SPI interface command monitor. please refer to:- [FTDI website](#) for full details.

4.3 Firmware Upgrades

Refer to the debugger interface section which can be used to update the firmware.

5 External circuit Configuration

5.1 Adding a second USB Port

The external circuit configuration for adding second USB host port, with the USB activity LED, is shown below in [Figure 5.1](#).

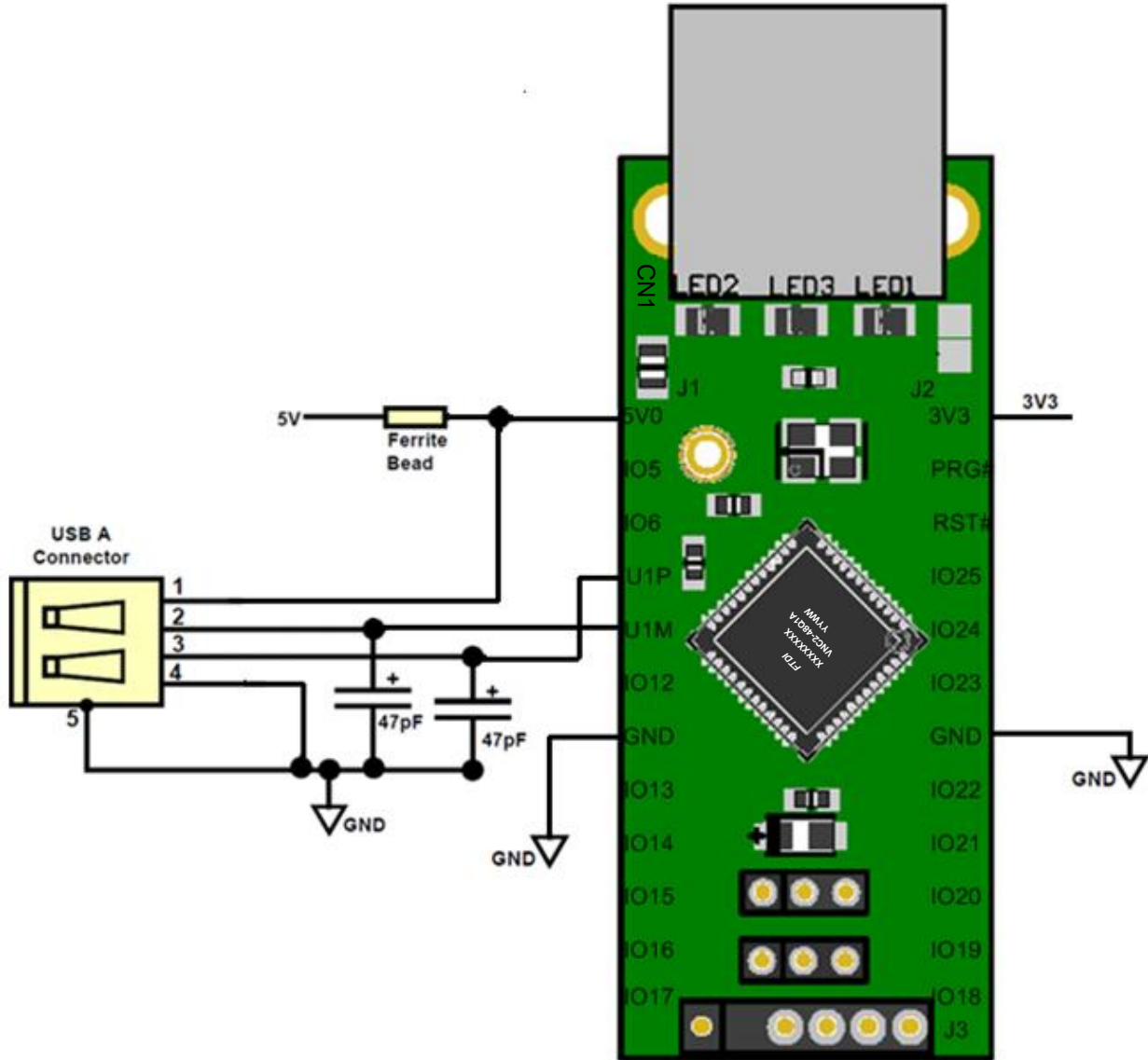

Figure 5.1 Additional USB Port Configuration

8 Contact Information

Head Office – Glasgow, UK

Future Technology Devices International Limited
Unit 1, 2 Seaward Place,
Centurion Business Park
Glasgow, G41 1HH
United Kingdom
Tel: +44 (0) 141 429 2777
Fax: +44 (0) 141 429 2758

E-mail (Sales) sales1@ftdichip.com
E-mail (Support) support1@ftdichip.com
E-mail (General Enquiries) admin1@ftdichip.com
Web Site URL <http://www.ftdichip.com>
Web Shop URL <http://www.ftdichip.com>

Branch Office – Taipei, Taiwan

Future Technology Devices International Limited (Taiwan)
2F, No 516, Sec. 1 NeiHu Road
Taipei 114
Taiwan, R.O.C.
Tel: +886 (0) 2 8791 3570
Fax: +886 (0) 2 8791 3576

E-mail (Sales) tw.sales1@ftdichip.com
E-mail (Support) tw.support1@ftdichip.com
E-mail (General Enquiries) tw.admin1@ftdichip.com
Web Site URL <http://www.ftdichip.com>

Branch Office – Hillsboro, Oregon, USA

Future Technology Devices International Limited (USA)
7235 NW Evergreen Parkway, Suite 600
Hillsboro, OR 97123-5803
USA
Tel: +1 (503) 547 0988
Fax: +1 (503) 547 0987

E-Mail (Sales) us.sales@ftdichip.com
E-Mail (Support) us.admin@ftdichip.com
Web Site URL <http://www.ftdichip.com>

Branch Office – Shanghai, China

Future Technology Devices International Limited (China)
Room 408, 317 Xianxia Road,
ChangNing District,
ShangHai, China

Tel: +86 (21) 62351596
Fax: +86(21) 62351595

E-Mail (Sales): cn.sales@ftdichip.com
E-Mail (Support): cn.support@ftdichip.com
E-Mail (General Enquiries): cn.admin1@ftdichip.com
Web Site URL <http://www.ftdichip.com>

Distributor and Sales Representatives

Please visit the Sales Network page of the FTDI Web site for the contact details of our distributor(s) and sales representative(s) in your country.

Appendix A – References

Application and Technical Notes

[Vinculum-II IO Cell Description](#)

[Vinculum-II Debug Interface Description](#)

[Vinculum-II IO Mux Explained](#)

[Vinculum-II PWM Example](#)

[Migrating Vinculum Designs From VNC1L to VNC2-48L1A](#)

[Vinculum-II Errata Technical Note](#)

Appendix B – List of Figures and Tables

List of Figures

Figure 1.1- V2DIP1 48.....	1
Figure 3.1 - V2DIP1 48 Module Pin Out (Top View)	4
Figure 3.2 - V2DIP1 48 Module Pin Out (Bottom View)	5
Figure 3.3 - V2DIP1 48 On-Board Jumper Pin Configuration.	8
Figure 3.4 – Asynchronous FIFO Mode Read and Write Cycle.....	13
Figure 3.5 - Synchronous FIFO Mode Read and Write Cycle.....	14
Figure 5.1 Additional USB Port Configuration.....	18
Figure 6.1 V2DIP1 48 Dimensions (Top View).....	19
Figure 7.1 - Schematic Diagram	20

List of Tables

Table 3.1 - Pin Signal Descriptions	6
Table 3.2 - V2DIP1 48 Port Selection Jumper Pins.....	8
Table 3.3 - Default Interface I/O Pin Configuration.....	9
Table 3.5 - Data and Control Bus Signal Mode Options – SPI Slave	11
Table 3.6 - Data and Control Bus Signal Mode Options – SPI Master	11
Table 3.7 - Data and Control Bus Signal Mode Options – Parallel FIFO Interface	12
Table 3.8 - Asynchronous FIFO Mode Read Cycle Timing.....	13
Table 3.9 - Data and Control Bus Signal Mode Options – Synchronous FIFO mode	14
Table 3.10 - Synchronous FIFO Mode Read and Write Cycle Timing.....	15
Table 3.11 - Signal Name and Description – Debugger Interface.....	16

Appendix C – Revision History

Version 1.0 First Release

16th April 2010



Компания «ЭлектроПласт» предлагает заключение долгосрочных отношений при поставках импортных электронных компонентов на взаимовыгодных условиях!

Наши преимущества:

- Оперативные поставки широкого спектра электронных компонентов отечественного и импортного производства напрямую от производителей и с крупнейших мировых складов;
- Поставка более 17-ти миллионов наименований электронных компонентов;
- Поставка сложных, дефицитных, либо снятых с производства позиций;
- Оперативные сроки поставки под заказ (от 5 рабочих дней);
- Экспресс доставка в любую точку России;
- Техническая поддержка проекта, помощь в подборе аналогов, поставка прототипов;
- Система менеджмента качества сертифицирована по Международному стандарту ISO 9001;
- Лицензия ФСБ на осуществление работ с использованием сведений, составляющих государственную тайну;
- Поставка специализированных компонентов (Xilinx, Altera, Analog Devices, Intersil, Interpoint, Microsemi, Aeroflex, Peregrine, Syfer, Eurofarad, Texas Instrument, Miteq, Cobham, E2V, MA-COM, Hittite, Mini-Circuits, General Dynamics и др.);

Помимо этого, одним из направлений компании «ЭлектроПласт» является направление «Источники питания». Мы предлагаем Вам помощь Конструкторского отдела:

- Подбор оптимального решения, техническое обоснование при выборе компонента;
- Подбор аналогов;
- Консультации по применению компонента;
- Поставка образцов и прототипов;
- Техническая поддержка проекта;
- Защита от снятия компонента с производства.



Как с нами связаться

Телефон: 8 (812) 309 58 32 (многоканальный)

Факс: 8 (812) 320-02-42

Электронная почта: org@eplast1.ru

Адрес: 198099, г. Санкт-Петербург, ул. Калинина, дом 2, корпус 4, литера А.