

MODEL CUB4RT/TC - INTELLIGENT TEMPERATURE INDICATORS



UL Recognized Component,
 File # E179259



- PROGRAMMABLE INPUTS
 CUB4TC - Thermocouple types T, E, J, K, R, S, B, N, or mV
 CUB4RT - RTD types Pt385, Pt392, Ni672, Cu427
- PROGRAMMABLE TEMPERATURE OFFSET
- SELECTABLE F or C WITH 1 or 0.1 RESOLUTION
- F OR C DISPLAY ANNUNCIATORS
- CONFORMS TO ITS-90 TEMPERATURE SCALE
- COLD JUNCTION COMPENSATION (Enable/Disable) CUB4TC
- 0.48 INCH (12.2 mm) HIGH DIGITS
- 5 DIGIT LCD, POSITIVE REFLECTIVE OR NEGATIVE TRANSMISSIVE WITH RED BACKLIGHT
- NEMA 4X/IP65 SEALED FRONT BEZEL

DESCRIPTION

These CUB4 temperature meters are 9 to 26 VDC powered, microprocessor based indicators, with a selectable decimal point. Models are available for use with RTD or Thermocouple sensors. The CUB4TC offers cold junction compensation and a mVDC display mode with a range of -10.00 to 60.00 mV. Programmable features include temperature type, Fahrenheit or Celsius display, input filtering range, and user offset.

SAFETY SUMMARY

All safety related regulations, local codes, and instructions that appear in the manual or on equipment must be observed to ensure personal safety and to prevent damage to either the instrument or equipment connected to it. If equipment is used in a manner not specified by the manufacturer, the protection provided by the equipment may be impaired.



SPECIFICATIONS

1. **DISPLAY:** Reflective LCD or Transmissive LCD with red backlight, 5 digit display 0.48"(12.2 mm) height, F or C annunciator.
2. **POWER:** 9 to 26 VDC @ 65 mA with backlight, 25 mA without backlight. Reverse polarity protected.
 Must use the MLPS or a Class 2 or SELV rated power supply.
CUB4TC Backlight version: 0.15 °C/Volt CJC error if powered from other than 12 VDC. May be compensated with offset.
 Example: 24 VDC supply, (24V-12V)*0.15 °C/V = 1.8 °C, Enter -1.8 °C user offset.
3. **TEMPERATURE EFFECTS:**
CUB4RT Span Drift: 100 ppm/°C Max
CUB4TC Span Drift: 150 ppm/°C Max.
Zero Drift: < 1 µV/°C Max.
4. **ENVIRONMENTAL CONDITIONS:**
Operating Temperature Range: 0 to 50 °C
Storage Temperature Range: -30 to 85 °C
Operating and Storage Humidity: 85% max. relative humidity (non-condensing) from 0 to 50 °C.
Altitude: Up to 2000 meters (6561 feet)
5. **MAIN SENSOR INPUT RANGES AND ACCURACIES**
Isolation: The sensor input and excitation, if applicable are not isolated from the power supply.
Response Time: 500 msec
Failed Sensor Display: OPEN
Overrange/Underrange Input: OLOL/ULUL
Overrange/Underrange Display: "....."/"....."
Normal Mode Rejection: 40 dB @ 50/60 Hz
Common Mode Rejection: 100 dB @ DC to 60 Hz
 Accuracies reflect ALL errors @ 12 VDC supply and 15 minute warm-up, except probe errors and lead resistance effects.

ORDERING INFORMATION

MODEL NO.	DESCRIPTION	PART NUMBER
CUB4RT	RTD Indicator, Reflective LCD	CUB4RT00
	RTD Indicator, Red Backlit Transmissive LCD	CUB4RT20
CUB4TC	Thermocouple Indicator, Reflective LCD	CUB4TC00
	Thermocouple Indicator, Red Backlit Transmissive LCD	CUB4TC20
MLPS	Micro Line/Sensor Power Supply	MLPS1000

DIMENSIONS In inches (mm)

Note: Recommended minimum clearance (behind the panel) for mounting clip installation is 2.1" (53.3) H x 3.0" (76.2) W.

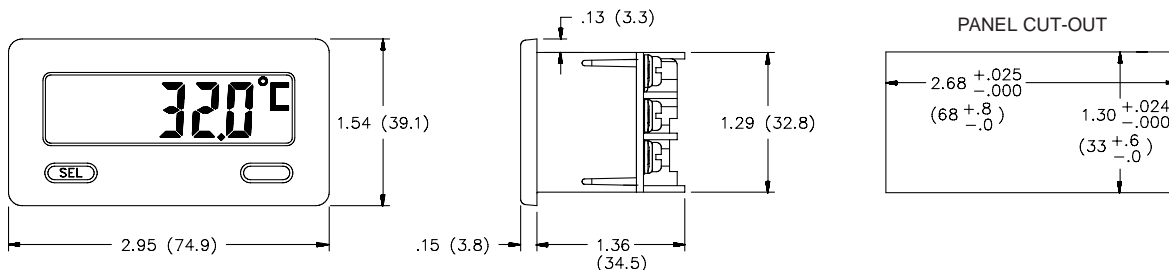

SPECIFICATIONS (Cont'd)

CUB4TC Thermocouple Inputs:

TC TYPE	DISPLAY	RANGE	ACCURACY* @ 23°C ±°C	ACCURACY* @ 0 to 50°C ±°C	WIRE COLOR	
					ANSI	BS 1843
T	t	-200 to 400°C -328 to 752°F	2.3	5.8	BLUE	WHITE
K	μ	-200 to 1372°C -328 to 2502°F	2.3	5.8	YELLOW	BROWN
J	∫	-200 to 760°C -328 to 1400°F	1.9	4.3	WHITE	YELLOW
R	r	0 to 1768°C 32 to 3214°F	4.5	15.0	BLACK	WHITE
S	∫	0 to 1768°C 32 to 3214°F	4.5	15.0	BLACK	WHITE
B	b	200 to 1820°C 300 to 3308°F	9.1<540°C 4.5>540°C	42.6<540°C 15.0>540°C	GREY	NONE
E	E	-200 to 787°C -328 to 1448°F	2.7	4.9	VIOLET	BROWN
N	n	-200 to 1300°C -328 to 2372°F	2.8	8.1	ORANGE	ORANGE
mV	L f#	-10.00 to 60.00	0.02 mV	0.08 mV	N/A	N/A

Input Impedance: 20 MΩ

Lead Resistance Effect: 0.03μV/ohm

Maximum Input Voltage: 30 VDC, TC+ to TC-

Maximum Input Voltage TC-: 3 VDC max. with respect to common

CUB4RT RTD Inputs:

Type	Jumper Position (See Wiring Diagram)	Nominal @ 0°C	Range	Accuracy * @ 23°C ±1LSD	Accuracy * @ 0 to 50°C ±1LSD
Pt392	B	100 Ohm	-200 to 850	±0.7°C	±2.7°C
Pt385	B	100 Ohm	-200 to 850	±0.7°C	±2.7°C
Ni672	B	120 Ohm	-80 to 260	±0.7°C	±1.5°C
Cu427	A	9.035 Ohm	-100 to 260	±0.9°C	±1.7°C

Lead Resistance:

Cu427: 3 ohms/lead, 6 ohms total

All others: 10 ohms/lead, 20 ohms total

Balanced Lead Resistance: Automatically compensated up to max per lead.

Unbalanced Lead Resistance: uncompensated

* After 20 min. warm-up. Accuracy specified for the 0 to 50°C operating range includes meter temperature coefficient and ice point tracking effects (TC only.) The accuracy specifications includes the A/D conversion errors, linearization conformity, and thermocouple ice point compensation (TC only.) Total system accuracy is the sum of the meter and probe errors. Accuracy may be improved by field calibrating the meter readout at the temperature of interest.

7. CERTIFICATIONS AND COMPLIANCES:

SAFETY

UL Recognized Component, File # E179259, UL3101-1, CSA 22.2 No. 1010-1

Recognized to U.S. and Canadian requirements under the Component Recognition Program of Underwriters Laboratories, Inc.

Type 4X Enclosure rating (Face only), UL50

IECEE CB Scheme Test Certificate #UL2356A-179259/USA,

CB Scheme Test Report #98ME60090-000098

Issued by Underwriters Laboratories Inc.

IEC 1010-1, EN 61010-1: Safety requirements for electrical equipment for measurement, control and laboratory use, Part 1.

IP65 Enclosure rating (Face only), IEC 529

ELECTROMAGNETIC COMPATIBILITY

Immunity to EN 50082-2

Electrostatic discharge	EN 61000-4-2	Level 2; 4 Kv contact Level 3; 8 Kv air
Electromagnetic RF fields	EN 61000-4-3	Level 3; 10 V/m ¹ 80 MHz - 1 GHz
Fast transients (burst)	EN 61000-4-4	Level 4; 2 Kv I/O Level 3; 2 Kv power
RF conducted interference	EN 61000-4-6	Level 3; 10 V/rms ² 150 KHz - 80 MHz
Simulation of cordless telephone	ENV 50204	Level 3; 10 V/m 900 MHz ± 5 MHz 200 Hz, 50% duty cycle

Emissions to EN 50081-1

RF interference	EN 55022	Enclosure class B
-----------------	----------	-------------------

Notes:

1. Self-recoverable loss of performance during EMI disturbance at 10 V/m:
Process signal may deviate during EMI disturbance.
For operation without loss of performance:
Unit is panel mounted in a metal enclosure (Buckeye SM7013-0 or equivalent).
I/O cables routed in metal conduit connected to earth ground.
2. Self-recoverable loss of performance during EMI disturbance at 10 Vrms:
Process signal may deviate during EMI disturbance.
For operation without loss of performance:
Install power line filter, RLC#LFIL0000 or equivalent, at the unit.
Refer to EMC Installation Guidelines section of the bulletin for additional information.

8. **CONNECTION:** Wire clamping screw terminals.

9. **CONSTRUCTION:** High impact plastic case with clear viewing window. (Panel gasket and mounting clips included.) Unit is rated for NEMA 4X/IP65 indoor use. Installation Category I, Pollution Degree 2.

10. **WEIGHT:** 3.3 oz. (93.5 g)

EMC INSTALLATION GUIDELINES

Although this unit is designed with a high degree of immunity to ElectroMagnetic Interference (EMI), proper installation and wiring methods must be followed to ensure compatibility in each application. The type of the electrical noise, source or coupling method into the unit may be different for various installations. In extremely high EMI environments, additional measures may be needed. The unit becomes more immune to EMI with fewer I/O connections. Cable length, routing and shield termination are very important and can mean the difference between a successful or a troublesome installation. Listed below are some EMC guidelines for successful installation in an industrial environment.

1. The unit should be mounted in a metal enclosure, that is properly connected to protective earth.
2. Use shielded (screened) cables for all Signal and Control inputs. The shield (screen) pigtail connection should be made as short as possible. The connection point for the shield depends somewhat upon the application. Listed below are the recommended methods of connecting the shield, in order of their effectiveness.
 - a. Connect the shield to earth ground (protective earth) only at the panel where the unit is mounted.
 - b. Connect the shield to earth ground at both ends of the cable, usually when the noise source frequency is above 1 MHz.
 - c. Connect the shield to common of the unit and leave the other end of the shield unconnected and insulated from earth ground.
3. Never run Signal or Control cables in the same conduit or raceway with AC power lines, conductors feeding motors, solenoids, SCR controls, and heaters, etc. The cables should be run in metal conduit that is properly

grounded. This is especially useful in applications where cable runs are long and portable two-way radios are used in close proximity, or if the installation is near a commercial radio transmitter.

4. Signal or Control cables within an enclosure should be routed as far away as possible from contactors, control relays, transformers, and other noisy components.

5. In extremely high EMI environments, the use of external EMI suppression devices, such as ferrite suppression cores, is effective. Install them on Signal and Control cables as close to the unit as possible. Loop the cable through the core several times or use multiple cores on each cable for additional protection. Install line filters on the power input cable to the unit to suppress power line interference. Install them near the power entry point of the enclosure. The following EMI suppression devices (or equivalent) are recommended:

Ferrite Suppression Cores for signal and control cables:

Fair-Rite # 0443167251 (RLC #FCOR0000)

TDK # ZCAT3035-1330A

Steward #28B2029-0A0

Line Filters for input power cables:

Schaffner # FN610-1/07 (RLC #LFIL0000)

Schaffner # FN670-1.8/07

Corcom #1VR3

Note: Reference manufacturer's instructions when installing a line filter.

6. Long cable runs are more susceptible to EMI pickup than short cable runs. Therefore, keep cable runs as short as possible.

WIRING CONNECTIONS

All conductors should meet voltage and current ratings of the unit. Also, cabling should conform to appropriate standards of good installation, local codes and regulations. It is recommended that power supplied to the unit be protected by a fuse or circuit breaker.

Unit should be mounted in a relatively stable temperature environment. Avoid drafts and areas subject to radical temperature shifts.

CUB4RT WIRING

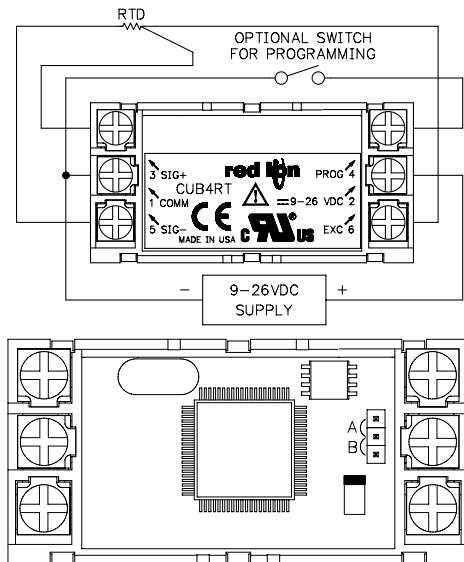

Jumper Positions

Electrical

Connect RTD wires to Terminals EXC (#6), SIG+ (#3) and SIG- (#5) as shown in the wiring diagram. Place jumper in appropriate position.

To minimize lead resistance effects, the three RTD wires should be the same length, gauge, and material. Keep wire length to a minimum. Do not run RTD signal wires with Class 1 wiring.

Connect the 9 to 26 VDC power to terminals VDC (#2) and COMM (#1), observing the correct polarity. If more than one CUB4RT are powered from the same supply, the probes must be isolated from each other. Normal operation does not require use of the PROG terminal. However, a switch may be installed between PROG (#4) and COMM (#1) if desired.

CUB4TC WIRING

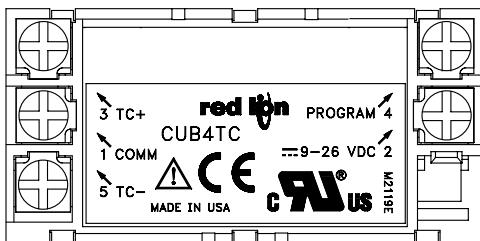

CAUTION: To maintain the SELV rating of the CUB4TC, the thermocouple probe should be isolated from any accidental contact with hazardous voltage or non-SELV circuitry.

Electrical

Connect thermocouple wires to terminals TC+ (#3) and TC- (#5), observing the correct polarity. Keep wire length to a minimum to reduce lead resistance errors. Do not run thermocouple wires with Class 1 wiring.

Connect the 9 to 26 VDC power to terminals VDC (#2) and COMM (#1), observing the correct polarity. If more than one CUB4TC are powered from the same supply, the probes must be isolated from each other.

Note: Do not connect the power supply COMM terminal (#1) to the TC-terminal (#5), as erroneous readings will result. Also be aware when using grounded thermocouple probes that the probes' protective sheath is electrically connected to the measuring junction. If the protective sheath is connected to the power supply common, this will connect terminals 1 and 5 together, which may result in erroneous readings.

BASIC OPERATION

Normal operation begins with application of power to the meter. The unit will begin a power up sequence that displays the version of the software and any diagnostic messages. After approximately four seconds, the unit will begin to display the temperature of the sensor or the millivolt input, depending upon input type selected.

A diagnostic message of **FAIL** may occur on power up. This message indicates that the stored programming and/or calibration values may have become corrupted. Pressing the "SEL" button will remove the current message from the display.

Once the unit is displaying temperature or millivolts, the "SEL" button may be pressed to display the type of input the unit has been programmed to display. The display will return to normal indication after three seconds.

DIAGNOSTIC MESSAGES

FAIL - indicates that a non-volatile memory fault has occurred. The operator must acknowledge this message by pressing the "SEL" button before proceeding to normal operation. Once the unit is in normal operation, the messages **FLPr9** and or **FLCAL** will be periodically flashed on the display.

FLPr9 - indicates that non-calibration data is corrupt. This flashing display will remain active even if power is removed and reapplied, until the unit is reprogrammed. If the message appears on next power up after the unit has been reprogrammed, it may indicate a nonfunctional memory component.

FLCAL - indicates that calibration data is corrupt and nominal values will be used to calculate the display value. This flashing display will remain active even if power is removed and reapplied, until the unit is recalibrated. If the message appears on next power up after the unit has been recalibrated, it may indicate a nonfunctional memory component. The nominal values used to calculate the input signal value may cause indication errors of up to 10% of full scale. The unit should be recalibrated to restore normal display accuracy as soon as possible.

PROGRAMMING

Programming may be entered at any time during normal operation. Entering the Program Menu of the meter is accomplished by electrically connecting the PROGRAM terminal to the COMM terminal with a wire or a switch.

Programming may be exited at any time except during calibration. Exiting the Program Menu is accomplished by disconnecting the electrical connection between the PROGRAM terminal and the COMM terminal. During exit of programming, the unit displays **SAVE** to indicate that the data is currently being written to non-volatile memory.

All programming data is stored upon exit of programming. If power is removed from the meter during exit of the Program Menu, data may not be saved completely or correctly, and may cause a **FAIL** message to occur during the next power-up cycle. If power is removed before exiting the Program Menu, all changes (including calibration information) will be lost and previous values will be used upon power-up.

Programming the meter involves using the "SEL" and "blank" buttons to traverse the Programming Menu and to select values for the corresponding Programming Menu Items.

SEL: Steps to next Program Menu selection.

Blank: Scrolls through selection variables and enters into programming for the selected value.

PROGRAM MENU - Selection Variables

TYPE - Pt392, Pt385, Ni672, Cu427 (CUB4RT Only)

To select the input type, press the blank button to scroll through the available input types. Press "SEL" button to enter the choice and return to the main menu.

TYPE - E, E, J, P, r, S, b, n, or L IN (CUB4TC Only)

To select the input type, press the blank button to scroll through the available input types. Press the "SEL" button to enter the choice and return to the main menu.

CE - YES, NO (CUB4TC Only)

This program item enables or disables internal cold junction compensation. Pressing the "blank" button toggles between Yes and No.

For most applications, cold junction compensation should be enabled (**YES**). Press the "SEL" button to enter the choice and return to the main menu.

This menu item does not appear if **TYPE = L IN**.

TEMP - 0C, 0.0C, 0F, 0.0F

This program item sets the display for Fahrenheit or Celsius and whole number or tenths. Tenths is not available for thermocouple types R, S, and B.

To change the display, use the "blank" button to scroll through the list of choices. Press the "SEL" button to enter the choice and return to the main menu.

This menu item does not appear if TYPE = L or H.

FLtEr - 0, 1, 2, 3

If the displayed process signal is difficult to read due to small process variations or noise, increased levels of filtering will help to stabilize the display. Software filtering effectively combines a fraction of the current input reading with a fraction of the previous displayed reading to generate the new display.

Filter values represent no filtering (0), up to heavy filtering (3). A value of 1 for the filter uses 1/4 of the new input and 3/4 of the previous display to generate the new display. A filter value of 2 uses 1/8 new and 7/8 previous. A filter value of 3 uses 1/16 new and 15/16 previous.

To select the filter level, use the "blank" button to scroll through the list of choices. Press the "SEL" button to enter the choice and return to the main menu.

RANGE - 00000 to 00099

The Range value selected determines if the filter, as set previously, will be applied to the new input sample. If the new input value is within the ± range of the previous display, the filter will be applied to the new input.

Example:

new input sample = 891 °C
previous display = 885 °C
range = 10 °C

885 ± 10 = 875 to 895 degree filter range based on previous display.

The new input sample (891 °C) is within ± 10 °C of the previous display (885°C), so the filter is applied to the new input signal.

If the new input is outside the filter range, no filter is used. This allows fast response to large signal changes and maximum filtering of small signal changes.

To enter the range value, use the "blank" button to increment the flashing digit. To select a new digit, press the "SEL" button. After the desired value is on the display, press and hold the "SEL" button for three seconds to enter the value and return to the main menu.

OFFSEt - ± 00000 to 99999

The offset value is used to add or subtract a constant temperature from the display. Typically this value should be zero. Changing this value does not affect calibration, but will affect the displayed temperature. If a constant offset error is occurring in the application, this feature may be used to reduce or eliminate that error.

To enter an offset value, use the "blank" button to increment the flashing digit or the sign of the number. To select a new digit or sign of the number, press the "SEL" button. If no digits are flashing, use the "blank" button to toggle the sign of the number or press the "SEL" button to wrap around to the LSD. After the desired value is on the display, press and hold the "SEL" button for three seconds to enter the value and return to the main menu.

CAL - YES/NO



Read the entire Calibration instructions before attempting to calibrate the unit. Access codes are contained in the calibration procedures. This unit is calibrated from the factory. Initial calibration is not necessary. Calibration should only be performed by individuals experienced in calibrating electronic equipment.

This item places the unit in calibration mode. Read the entire Calibration section before attempting to calibrate this unit. If calibration is entered by accident, press and hold the "SEL" button when the display shows 00000 for access code. Approximately three seconds later the display will return to TYPE in the Program Menu.

To enter the Calibration Mode, use the "blank" button to change the NO to YES. Press the "SEL" button to enter the choice.

CALIBRATING THE CUB4RT

The CUB4RT uses stored voltage and resistance calibration values to provide accurate temperature measurements. Over time, the electrical characteristics of the components inside the CUB4RT will slowly change with the result that the stored calibration values no longer accurately define the input circuit. For most applications, recalibration every 1 to 2 years should be sufficient.

Calibration of the CUB4RT involves a voltage calibration and a resistance calibration. Allow 30 minute warm-up before performing any calibration related procedure. The following procedures should be performed at an ambient temperature of 15 to 35°C (59 to 95°F).

Calibration should only be performed by individuals experienced in calibrating electronic equipment.

CAUTION: The accuracy of the calibration equipment will directly affect the accuracy of the CUB4RT.

Calibration Check

1. Connect a precision resistance decade box with an accuracy of ± 0.01 ohms to the unit as a three wire RTD. See Calibration Wiring Diagram All RTD Wires should be the same length, gauge, and material. Keep wire length to a minimum.
2. Verify that the unit is programmed for the correct RTD type.
3. Verify that the unit is programmed for a value of zero for OFFSEt.
4. Verify that the input jumper is in the correct position.
5. Set the precision resistance decade box to the values shown below and verify that the display reads accordingly. ± 0.9°C for Cu427, and ± 0.7°C for all other RTD types.

Type	Pt392		Pt385		Ni672		Cu427	
Jumper	Pos B		Pos B		Pos B		Pos A	
	OHMS	°C	OHMS	°C	OHMS	°C	OHMS	°C
	17	-200.1	18	-201.1	66	-80.9	5	-103.2
	20	-193.2	20	-196.5	70	-74.8	6	-78.0
	80	-49.9	80	-50.8	120	-0.0	8	-26.8
	140	102.1	140	104.0	170	64.9	10	25.0
	200	261.4	200	266.4	220	120.7	12	76.7
	260	429.3	260	437.9	270	170.1	14	128.5
	320	607.1	320	619.9	320	213.8	16	180.1
	380	797.3	380	815.2	370	252.5	18	231.3
	396	850.3	391	852.5	379	259.0	20	282.6

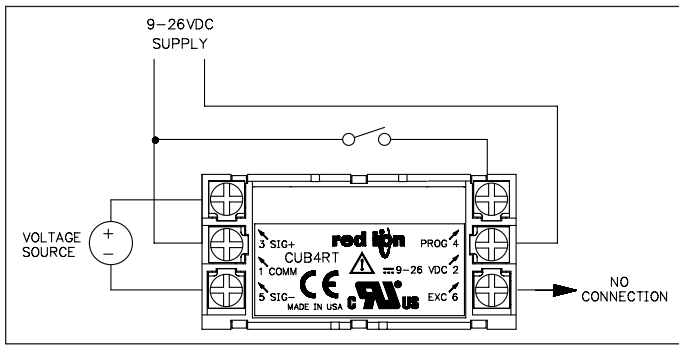

Voltage Calibration Diagram

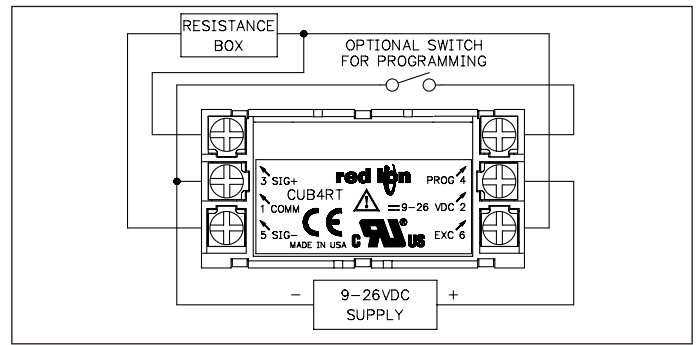

Resistance Calibration Diagram

1. Connect a precision Voltage Source with an output range of 0.000 to 105.000 mV and an accuracy of 0.03% or better to the SIG+ (#3) and SIG- (#5) terminals. Placement of jumper does not affect voltage calibration.
2. Enter the Program Menu and step through the Program Menu list by pressing the "SEL" button until **CAL** is displayed.
3. Press the "blank" button to change **no** to **YES**. Press "SEL".
4. The display shows **00000**. Use the "blank" button to increment the access code to **00006**. Press and hold "SEL".
5. After entering the correct access code, the unit will display **111**. Follow the table below for calibration sequence. The unit displays **CALL** for about 3 seconds after pressing the "SEL" button before proceeding to the next input point.

mV DISPLAY	PARAMETER	ACTION
111	0.000 mV	Apply 0.000 mV, wait 5 sec., press SEL
112	15.000 mV	Apply 15.000 mV, wait 5 sec., press SEL
113	30.000 mV	Apply 30.000 mV, wait 5 sec., press SEL
114	45.000 mV	Apply 45.000 mV, wait 5 sec., press SEL
115	60.000 mV	Apply 60.000 mV, wait 5 sec., press SEL
116	75.000 mV	Apply 75.000 mV, wait 5 sec., press SEL
117	90.000 mV	Apply 90.000 mV, wait 5 sec., press SEL
118	105.000 mV	Apply 105.000 mV, wait 5 sec., press SEL

6. After voltage calibration is complete, the display will show **r 200**.
7. Place the input selector jumper in position 'B'.
8. Connect a precision resistance decade box with an accuracy of ± 0.01 ohms to the unit as a three wire RTD. See Resistance Calibration Diagram.
9. With the display showing **r 200**, set the resistance to 200 ohms, then press the "SEL" button. The unit displays **CALL** for a few seconds and then the display will change to **r 0**.

10. With the display showing **r 0**, set the resistance to 0 ohms, then press the "SEL" button. The unit displays **CALL** for a few seconds and then the display will change to **r 400**.
11. With the display showing **r 400**, set the resistance to 400 ohms, then press the "SEL" button. The unit displays **CALL** for a few seconds and then the display will change to **r 10**.
12. Change the input selector jumper to position 'A'.
13. With the display showing **r 10**, set the resistance to 10 ohms, then press the "SEL" button. The unit displays **CALL** for a few seconds and then the display will change to **r 0**.
14. With the display showing **r 0**, set the resistance to 0 ohms, then press the "SEL" button. The unit displays **CALL** for a few seconds and then the display will change to **r 20**.
15. With the display showing **r 20**, set the resistance to 20 ohms, then press the "SEL" button. The unit displays **CALL** for a few seconds and then the unit will return to the **CAL** program item.

Before exiting the programming menu, verify that the **TYPE** is set to the desired type and the input selector jumper is in the appropriate position. Exit programming and check the calibration. Repeat if necessary

Entering code **85** will place the CUB4TC in a resistance display mode. This mode is for diagnostic purposes only. When power is removed from the CUB4TC, the display will return to its previously programmed state. If the RTD type is set for **CU427** and the jumper is set to position A, the display will read **00000** to **20000** ohms. All other RTD types with the jumper in position B, will cause the display to read **00000** to **40000** ohms

CALIBRATING THE CUB4TC

The CUB4TC uses stored voltage calibration and cold junction temperature values to provide accurate temperature and voltage measurements. Over time, the electrical characteristics of the components inside the CUB4TC will slowly change with the result that the stored calibration values no longer accurately define the input circuit. For most applications, recalibration every 1 to 2 years should be sufficient.

Calibration of the CUB4TC involves a voltage calibration and a cold junction calibration. It is recommended that both calibrations be performed. The voltage calibration **MUST** precede the cold junction calibration. Allow 30 minute warm-up before performing any calibration related procedure. The following procedures should be performed at an ambient temperature of 15 to 35 °C (59 to 95 °F).

Calibration should only be performed by individuals experienced in calibrating electronic equipment.

CAUTION: The accuracy of the calibration equipment will directly affect the accuracy of the CUB4TC.

Voltage Calibration Check

1. Enter the programming menu and set **TYPE** to **L 11** and **OFFSEt** to **0**. Exit programming.
2. Use a precision DC voltage supply with an accuracy of 0.03% or better. Connect the negative lead of the power supply to TC- (#5) and the positive lead of the power supply to TC+ (#3).

3. Compare the CUB4TC read-out to the precision DC supply at various points over the range (-10.00 mVDC to 60.00 mVDC). The tolerance is ± 2 LSD (± 0.02 mV), at all points within this range.
4. Calibrate the CUB4TC if the readings are out of tolerance.

Cold Junction Calibration Check

1. Enter Programming Menu, and verify the following:

TYPE = probe being connected to the unit.
CUt = **YES**
d 15P = **00°C**
OFFSEt = **0**

- Make any necessary changes to programming.
2. Connect a thermocouple probe of known accuracy and type (J, K, E, T, or N) to the CUB4TC. The probe should match the one selected in programming.
3. Connect a reference temperature probe to measuring end of thermocouple to monitor temperature. Allow sufficient time for temperatures to equalize (at least 15 minutes).
4. Compare unit display with reference temperature indicator. The unit display should equal the reference probe temperature. Tolerance is ± 1.0 °C.
5. Calibrate the cold junction temperature if out of tolerance.

VOLTAGE CALIBRATION

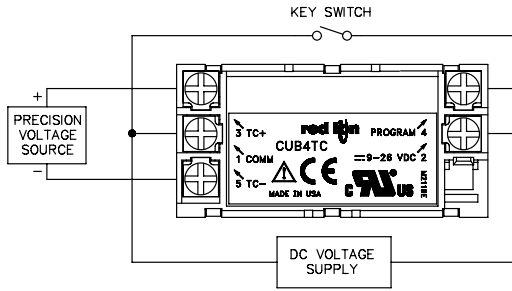

Voltage Calibration Wiring

1. Connect a precision Voltage Source with an output range of -10.000 mV and an accuracy of 0.03% or better to the TC- (#5) and TC+ (#3) terminals. Cold junction calibration must be performed AFTER voltage calibration.
2. Enter the Program Menu and step through the Program Menu list by pressing the “SEL” button until **CAL** is displayed.
3. Press the “blank” button to change **na** to **YES**. Press “SEL”.
4. The display shows **00000**. Use the “blank” button to increment the access code to **00006**. Press and hold “SEL”.
5. After entering the correct access code, the unit will display **IN 1**. Follow the table below for calibration sequence. The unit displays **CALC** for about 3 seconds after pressing the “SEL” button before proceeding to the next input point.

DISPLAY	PARAMETER	ACTION
IN 1	-10.000 mV	Apply -10.000 mV, wait 5 sec., press SEL
IN 2	0.000 mV	Apply 0.000 mV, wait 5 sec., press SEL
IN 3	10.000 mV	Apply 10.000 mV, wait 5 sec., press SEL
IN 4	20.000 mV	Apply 20.000 mV, wait 5 sec., press SEL
IN 5	30.000 mV	Apply 30.000 mV, wait 5 sec., press SEL
IN 6	40.000 mV	Apply 40.000 mV, wait 5 sec., press SEL
IN 7	50.000 mV	Apply 50.000 mV, wait 5 sec., press SEL
IN 8	60.000 mV	Apply 60.000 mV, wait 5 sec., press SEL

6. After voltage calibration is complete, the unit will return to the **CAL** program item. Exit programming and verify various points from -10.00 to 60.00 mVDC using the Voltage Calibration Check procedure to ensure that the calibration is correct.
7. Repeat calibration if necessary.

COLD JUNCTION CALIBRATION

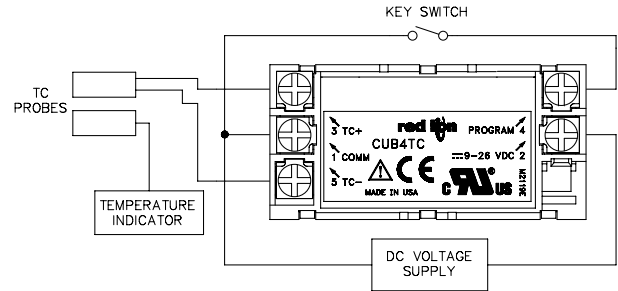

Cold Junction Calibration Wiring

This procedure must be performed AFTER an accurate voltage calibration. The ambient temperature at which this calibration should be performed is 15 to 35 °C (59 to 95 °F). A Temperature indicator with 0.1 °C resolution and accuracy is required to perform this calibration.

1. Enter Programming Menu, and verify the following:

TYPE = probe being connected to the unit.
CJC = **YES**
dISP = **00°C**
OFFSEt = **0**

Make any necessary changes to programming.

2. Connect a thermocouple probe of known accuracy and type (J, K, E, T, or N) to the CUB4TC. The probe should match the one selected in programming.
3. Connect a reference temperature probe to measuring end of the CUB4TC thermocouple. The two probes should be shielded from air movement and allowed sufficient time (15 minutes minimum) to equalize in temperature. (As an alternative, the CUB4TC thermocouple probe may be placed in a calibration bath of known temperature.)
4. Compare the unit display with reference temperature indicator (or calibration bath). If the displayed unit temperature does not equal the reference probe temperature, calculate the CJ error as follows:
 $CJ\ Error = reference\ probe\ temperature - CUB4TC\ displayed\ temperature$
5. Enter the Program Menu and step through the Program Menu list by pressing the “SEL” button until **CAL** is displayed.
6. Press the “blank” button to change **na** to **YES**. Press “SEL”.
7. The display shows **00000**. Use the “blank” button to increment the access code to **00003**. Press and hold “SEL”.
8. After entering the correct access code, the display will alternate between **CJC** and the current cold junction compensation value.
9. If the current CJC value is 0.0 °C or 59.9 °C, set the **CJC** value to the current ambient temperature, exit calibration, and repeat the CJC calibration procedure.
10. Otherwise, the new value to be entered is the sum of the current value and the CJ Error recorded previously.
11. Exit the Programming Menu and repeat the calibration from Step 4 to verify accuracy.

INSTALLATION

The meter meets NEMA 4X/IP65 requirements for indoor use, when properly installed. The units are intended to be mounted on an enclosed panel. The viewing window and buttons are factory sealed for a wash down environment. A sponge rubber gasket and mounting clip are provided for sealing the unit in the panel cut-out.

Installation Environment

The unit should be installed in a location that does not exceed the maximum operating temperature and provides good air circulation. Placing the unit near devices that generate excessive heat should be avoided.

The bezel should be cleaned only with a soft cloth and neutral soap product. Do NOT use solvents.

Continuous exposure to direct sunlight may accelerate the aging process of the bezel.

Do not use tools of any kind (screwdrivers, pens, pencils, etc.) to operate the buttons of this unit.

The following procedure assures proper installation:

1. Cut the panel opening to the specified dimensions. Remove burrs and clean around the panel opening.
2. Carefully slide the panel gasket over the rear of the unit to the back of the bezel.
3. Assemble the nut fastener and mounting screw onto both sides of the mounting clip. The tip of the screw should not project from the hole in the mounting clip.
4. Install the unit through the panel cut-out until the front bezel flange contacts the panel.
5. Slide the mounting clip over the rear of the unit until the mounting clip is against the back of the panel. The mounting clip has latching features which engage into mating features on the housing.

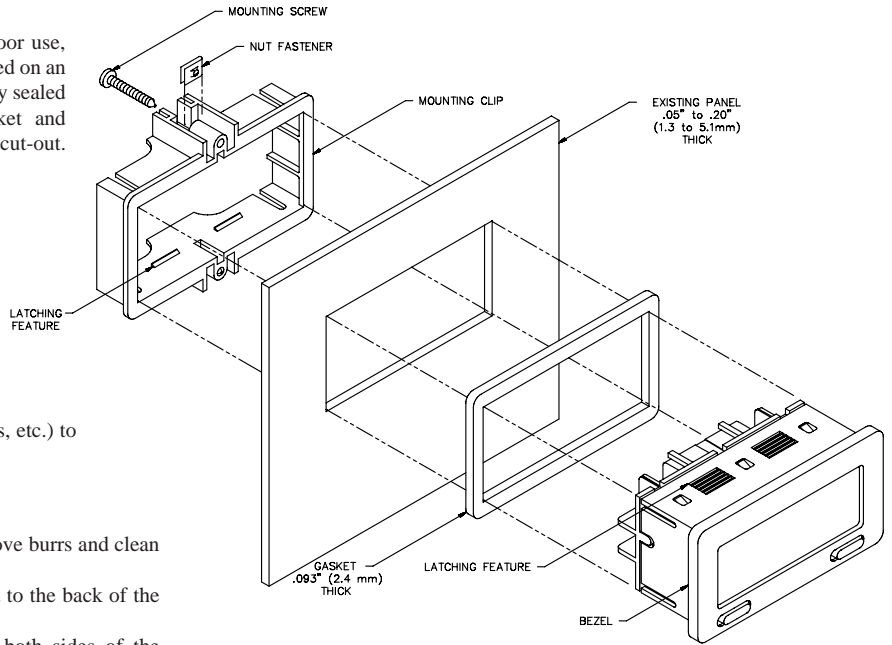

6. Alternately tighten each screw to ensure uniform gasket pressure. Visually inspect the front panel gasket. The gasket should be compressed to about 75 to 80% of its original thickness. (Recommended torque is 28 to 36 in-oz.) If not, gradually turn the mounting screws to further compress the gasket.
7. If the gasket is not adequately compressed, and the mounting screws can no longer be turned, loosen the mounting screws and check that the mounting clip is latched as close as possible to the panel. Repeat the procedure for tightening the mounting screws.

APPLICATION FOR CUB4RT

Relative Temperature Error Display

A customer desires to display the difference between the actual temperature of an oven and the desired temperature of 475.0°F. If the temperature of the oven is 464.8°F, the display should read -10.2°F. A Pt392 type RTD is used.

The user offset capability of the CUB4RT allows for this type of temperature indication.

Desired oven temp = 475.0°F, set offset for -475.0. Unit will display the temperature relative to 475.0°F.

Programming:

TYPE = Pt392
DISP = 00 °F
FLtEr = 1
rANGE = 5 °F
OFFSEt = -475.0 °F

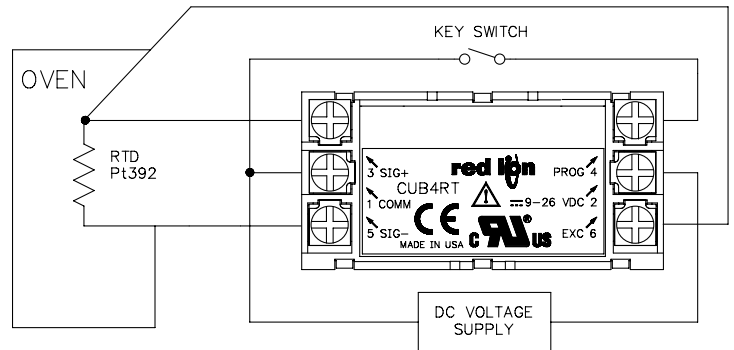

APPLICATION FOR CUB4TC

Relative Temperature Error Display

A customer desires to display the difference between the actual temperature of an oven and the desired temperature of 475.0 °F. If the temperature of the oven is 464.8 °F the display should read -10.2 °F. A K type thermocouple is to be used.

The user offset capability of the CUB4TC allows for this type of temperature indication. A key switch has been installed between PROGRAM and COMM to allow programming of the unit.

Desired oven temp = 475.0 °F, set offset for -475.0. Unit will display the temperature relative to 475.0 °F.

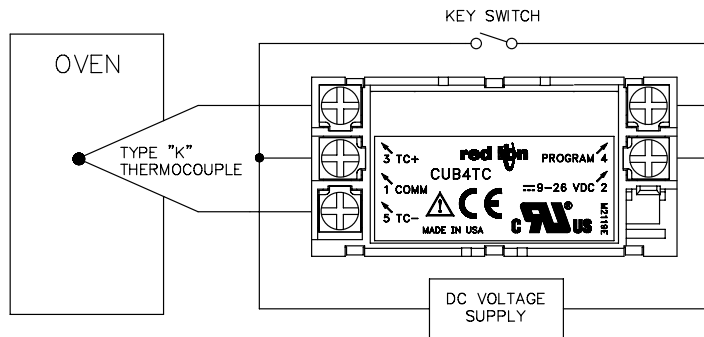

Programming:

TYPE = K
CUC = YES
dISP = 0.0 °F
FLtEr = 1
rANGE = 5 °F
OFFSEt = -475.0 °F

TROUBLESHOOTING

For further technical assistance, contact technical support at the number listed on the front of the bulletin.

LIMITED WARRANTY

The Company warrants the products it manufactures against defects in materials and workmanship for a period limited to one year from the date of shipment, provided the products have been stored, handled, installed, and used under proper conditions. The Company's liability under this limited warranty shall extend only to the repair or replacement of a defective product, at The Company's option. The Company disclaims all liability for any affirmation, promise or representation with respect to the products.

The customer agrees to hold Red Lion Controls harmless from, defend, and indemnify RLC against damages, claims, and expenses arising out of subsequent sales of RLC products or products containing components manufactured by RLC and based upon personal injuries, deaths, property damage, lost profits, and other matters which Buyer, its employees, or sub-contractors are or may be to any extent liable, including without limitation penalties imposed by the Consumer Product Safety Act (P.L. 92-573) and liability imposed upon any person pursuant to the Magnuson-Moss Warranty Act (P.L. 93-637), as now in effect or as amended hereafter.

No warranties expressed or implied are created with respect to The Company's products except those expressly contained herein. The Customer acknowledges the disclaimers and limitations contained herein and relies on no other warranties or affirmations.

Red Lion Controls
20 Willow Springs Circle
York PA 17402
Tel +1 (717) 767-6511
Fax +1 (717) 764-0839

Red Lion Controls BV
Basicweg 11b
NL - 3821 BR Amersfoort
Tel +31 (0) 334 723 225
Fax +31 (0) 334 893 793

Red Lion Controls AP
31, Kaki Bukit Road 3,
#06-04/05 TechLink
Singapore 417818
Tel +65 6744-6613
Fax +65 6743-3360



Компания «ЭлектроПласт» предлагает заключение долгосрочных отношений при поставках импортных электронных компонентов на взаимовыгодных условиях!

Наши преимущества:

- Оперативные поставки широкого спектра электронных компонентов отечественного и импортного производства напрямую от производителей и с крупнейших мировых складов;
- Поставка более 17-ти миллионов наименований электронных компонентов;
- Поставка сложных, дефицитных, либо снятых с производства позиций;
- Оперативные сроки поставки под заказ (от 5 рабочих дней);
- Экспресс доставка в любую точку России;
- Техническая поддержка проекта, помощь в подборе аналогов, поставка прототипов;
- Система менеджмента качества сертифицирована по Международному стандарту ISO 9001;
- Лицензия ФСБ на осуществление работ с использованием сведений, составляющих государственную тайну;
- Поставка специализированных компонентов (Xilinx, Altera, Analog Devices, Intersil, Interpoint, Microsemi, Aeroflex, Peregrine, Syfer, Eurofarad, Texas Instrument, Miteq, Cobham, E2V, MA-COM, Hittite, Mini-Circuits, General Dynamics и др.);

Помимо этого, одним из направлений компании «ЭлектроПласт» является направление «Источники питания». Мы предлагаем Вам помощь Конструкторского отдела:

- Подбор оптимального решения, техническое обоснование при выборе компонента;
- Подбор аналогов;
- Консультации по применению компонента;
- Поставка образцов и прототипов;
- Техническая поддержка проекта;
- Защита от снятия компонента с производства.



Как с нами связаться

Телефон: 8 (812) 309 58 32 (многоканальный)

Факс: 8 (812) 320-02-42

Электронная почта: org@eplast1.ru

Адрес: 198099, г. Санкт-Петербург, ул. Калинина, дом 2, корпус 4, литера А.