

# Silicon NPN Phototransistor in SMT SIDELED®-Package

## Version 1.3

### SFH 325



#### Features:

- **Spectral range of sensitivity:** (typ) 450 ... 1120 nm
- **Package:** SIDELED
- **Special:** High linearity
- P-LCC-2 package
- Available in groups
- The product qualification test plan is based on the guidelines of AEC-Q101-REV-C, Stress Test Qualification for Automotive Grade Discrete Semiconductors.

#### Applications

- Miniature photointerrupters
- Industrial electronics
- For control and drive circuits

#### Ordering Information

Type:	Photocurrent $I_{PCE}$ [ $\mu$ A] $\lambda = 950 \text{ nm}$ , $E_e = 0.1 \text{ mW/cm}^2$ , $V_{CE} = 5 \text{ V}$	Ordering Code
SFH 325	16 ... 80	Q65110A2486
SFH 325-3	25 ... 50	Q65110A2488
SFH 325-3/4	25 ... 80	Q65110A2491
SFH 325-4	40 ... 80	Q65110A2484

*Note:* Binning in half groups (see page 3), packing unit = only one half group

**Maximum Ratings** ( $T_A = 25\text{ °C}$ )

Parameter	Symbol	Values	Unit
Operating and storage temperature range	$T_{op}; T_{stg}$	-40 ... 100	°C
Collector-emitter voltage	$V_{CE}$	35	V
Collector current	$I_C$	15	mA
Collector surge current ( $\tau < 10\ \mu\text{s}$ )	$I_{CS}$	75	mA
Total Power dissipation	$P_{tot}$	165	mW
ESD withstand voltage (acc. to ANSI/ ESDA/ JEDEC JS-001 - HBM)	$V_{ESD}$	2000	V
Thermal resistance for mounting on pcb	$R_{thJA}$	450	K/W

**Characteristics** ( $T_A = 25\text{ °C}$ )

Parameter		Symbol	Values	Unit
Wavelength of max. sensitivity	(typ)	$\lambda_{S\ max}$	980	nm
Spectral range of sensitivity	(typ)	$\lambda_{10\%}$	(typ) 450 ... 1120	nm
Radiant sensitive area	(typ)	A	0.038	mm <sup>2</sup>
Dimensions of chip area	(typ)	L x W	(typ) 0.45 x 0.45	mm x mm
Half angle	(typ)	$\varphi$	$\pm 60$	°
Capacitance ( $V_{CE} = 0\text{ V}$ , $f = 1\text{ MHz}$ , $E = 0$ )	(typ)	$C_{CE}$	5	pF
Dark current ( $V_{CE} = 20\text{ V}$ , $E = 0$ )	(typ (max))	$I_{CE0}$	1 ( $\leq 50$ )	nA

## Grouping

Group	Min Photocurrent $E_e = 0.1 \text{ mW/cm}^2$ , $V_{CE} = 5 \text{ V}$ $I_{PCE, min} [\mu\text{A}]$	Max Photocurrent $E_e = 0.1 \text{ mW/cm}^2$ , $V_{CE} = 5 \text{ V}$ $I_{PCE, max} [\mu\text{A}]$	Typ Photocurrent $E_V = 1000 \text{ lx, Std. Light A, } V_{CE} = 5 \text{ V}$ $I_{PCE} [\mu\text{A}]$	Rise and fall time $I_C = 1 \text{ mA, } V_{CC} = 5 \text{ V, } R_L = 1 \text{ k}\Omega$ $t_r, t_f [\mu\text{s}]$
-2A	16	25	360	6
-2B	20	32	450	6
-3A	25	40	570	7
-3B	32	50	720	7
-4A	40	63	900	8
-4B	50	80	1140	8

Group	Collector-emitter saturation voltage $I_C = I_{PCEmin} \times 0.3, E_e = 0.1 \text{ mW/cm}^2$ $V_{CEsat} [\text{mV}]$
-2A	150
-2B	150
-3A	150
-3B	150
-4A	150
-4B	150

Note.:  $I_{PCEmin}$  is the min. photocurrent of the specified group.

**Relative Spectral Sensitivity** <sup>1) page 14</sup>

$S_{rel} = f(\lambda)$

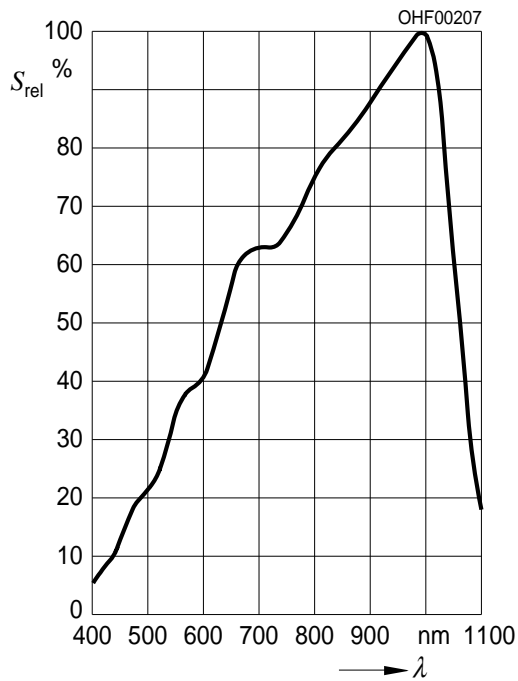

**Photocurrent** <sup>1) page 14</sup>

$I_{PCE} = f(E_e), V_{CE} = 5 V$

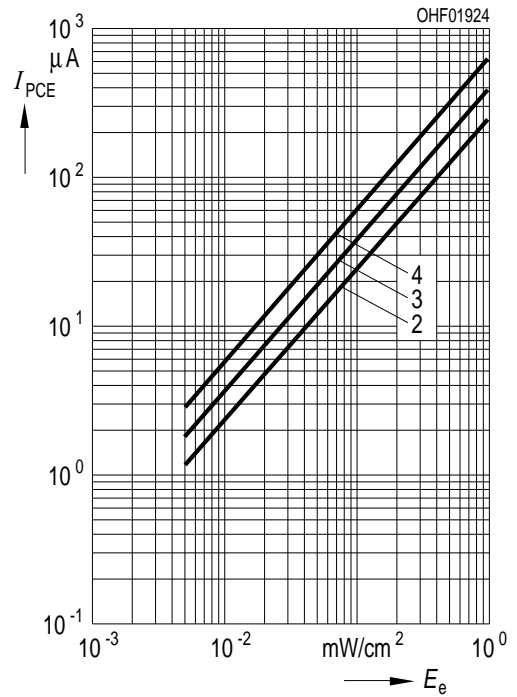

**Photocurrent** <sup>1) page 14</sup>

$I_{PCE} = f(V_{CE}), E_e = \text{Parameter}$

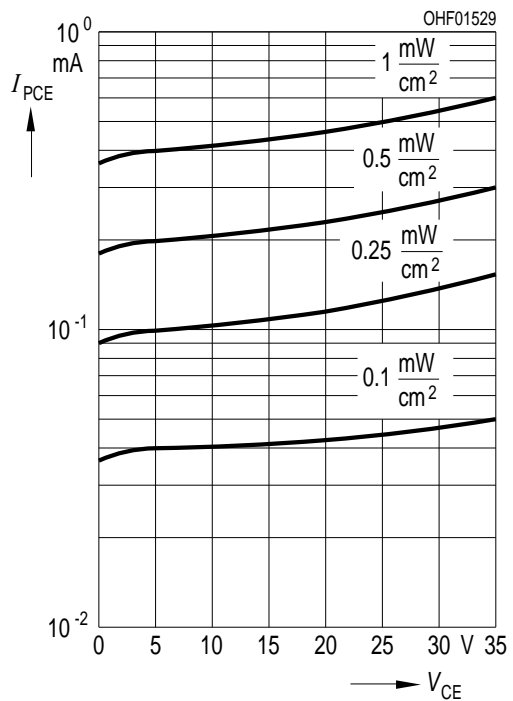

**Photocurrent** <sup>1) page 14</sup>

$I_{PCE} / I_{PCE}(25^\circ C) = f(T_A), V_{CE} = 5 V$

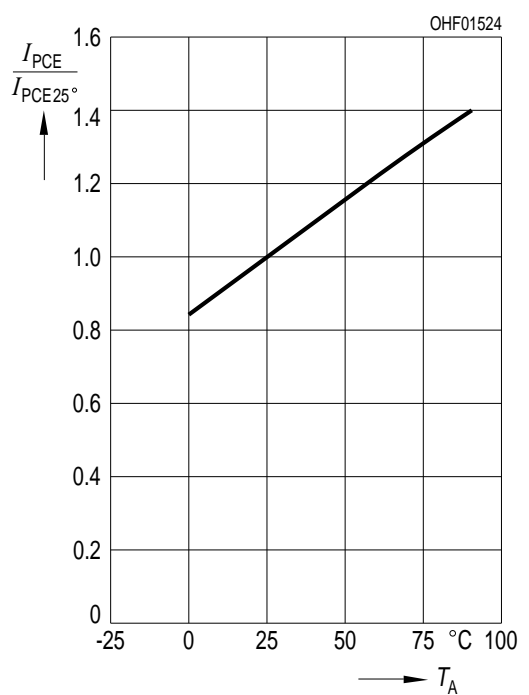

**Dark Current** <sup>1) page 14</sup>

$I_{CEO} = f(V_{CE}), E = 0$

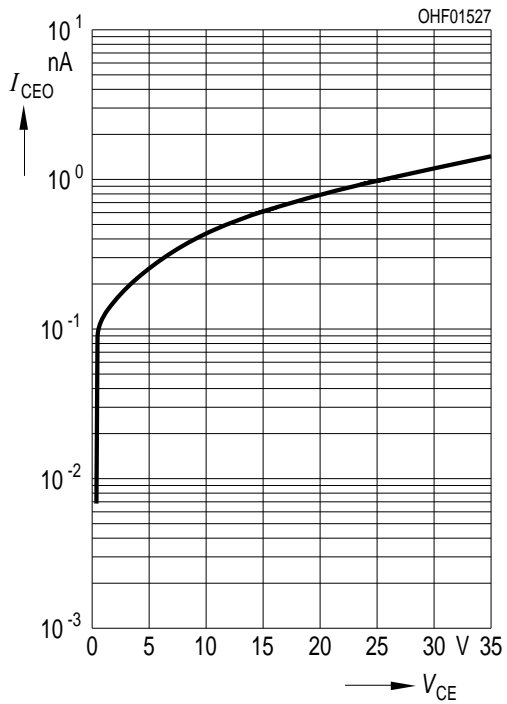

**Dark Current** <sup>1) page 14</sup>

$I_{CEO} = f(T_A), E = 0$

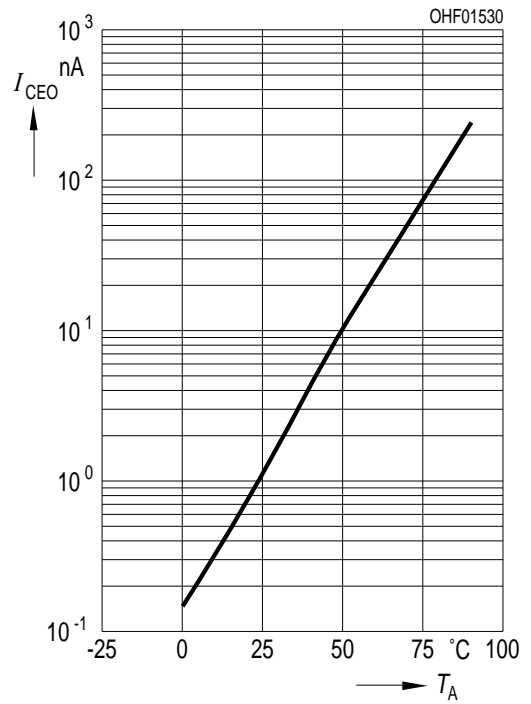

**Collector-Emitter Capacitance** <sup>1) page 14</sup>

$C_{CE} = f(V_{CE}), f = 1 \text{ MHz}, E = 0$

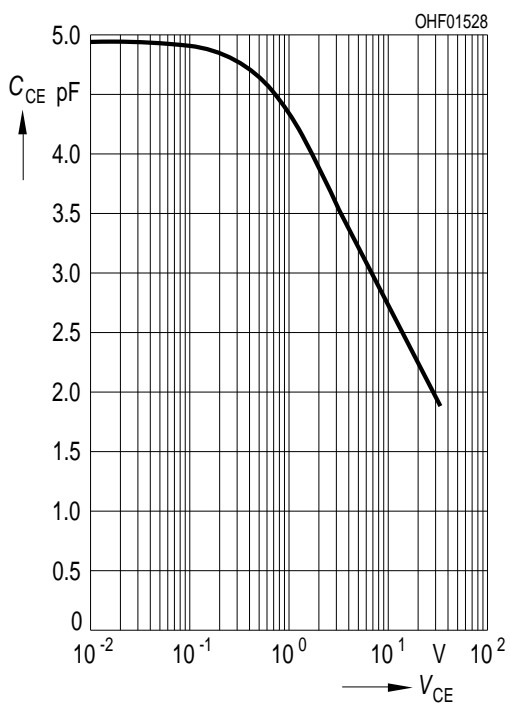

**Power Consumption**

$P_{tot} = f(T_A)$

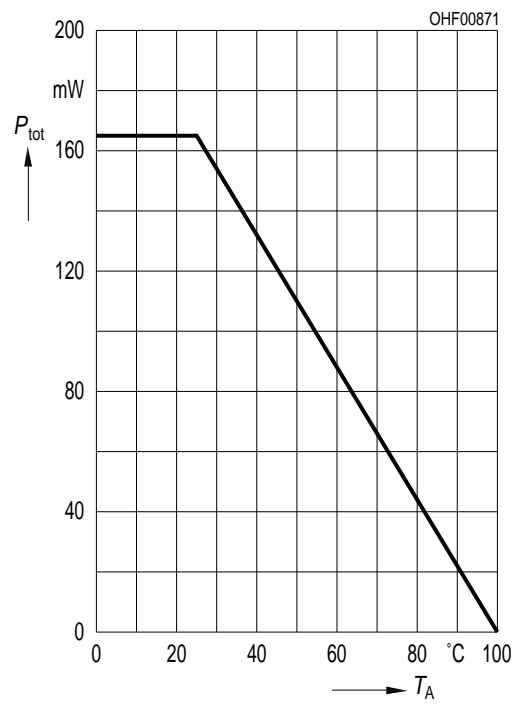

Directional Characteristics <sup>1) page 14</sup>

$S_{rel} = f(\phi)$

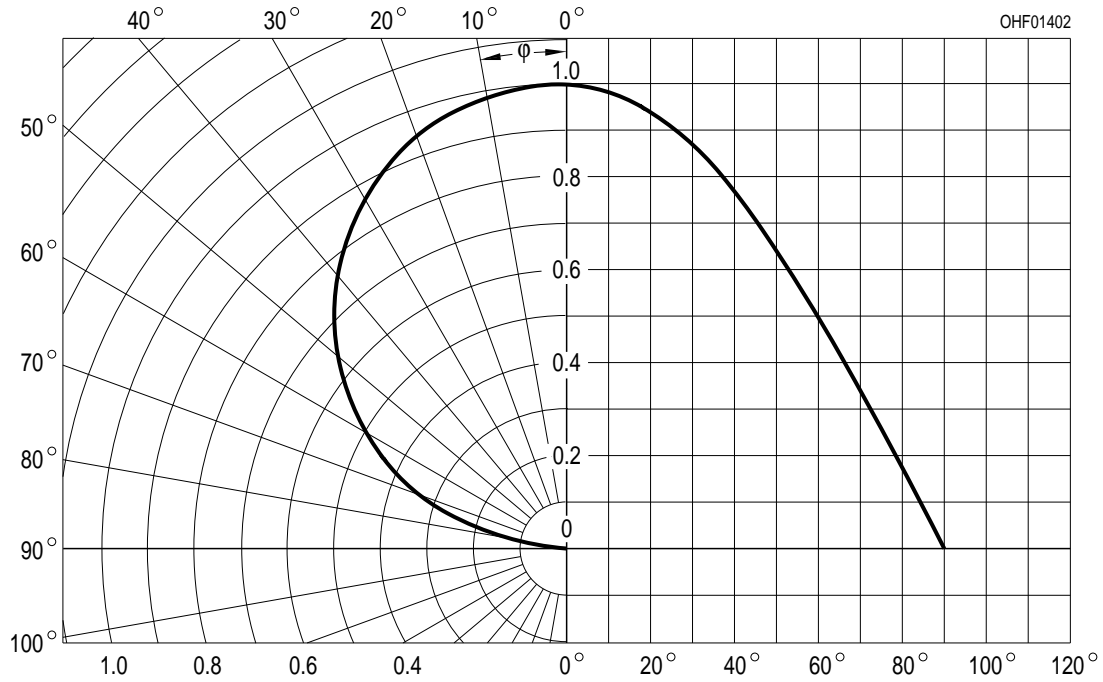

Package Outline

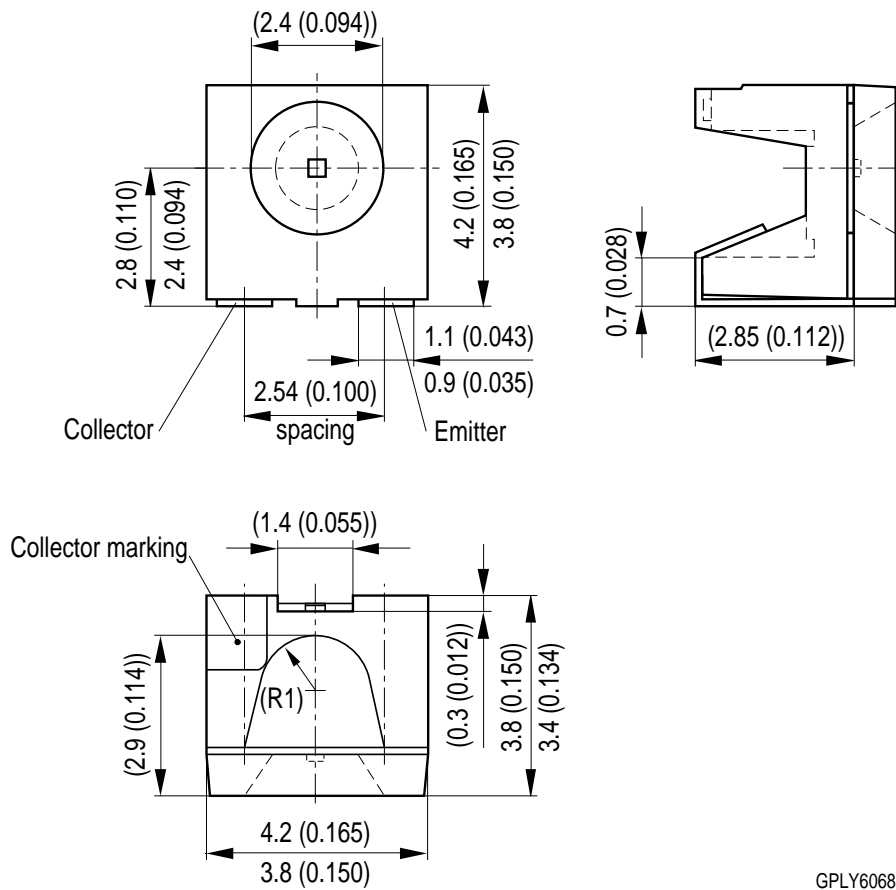

GPLY6068

*Dimensions in mm (inch).*

**Package**  
SIDELED

**Approximate Weight:**  
76 mg

**Recommended Solder Pad**

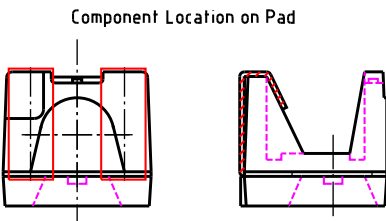
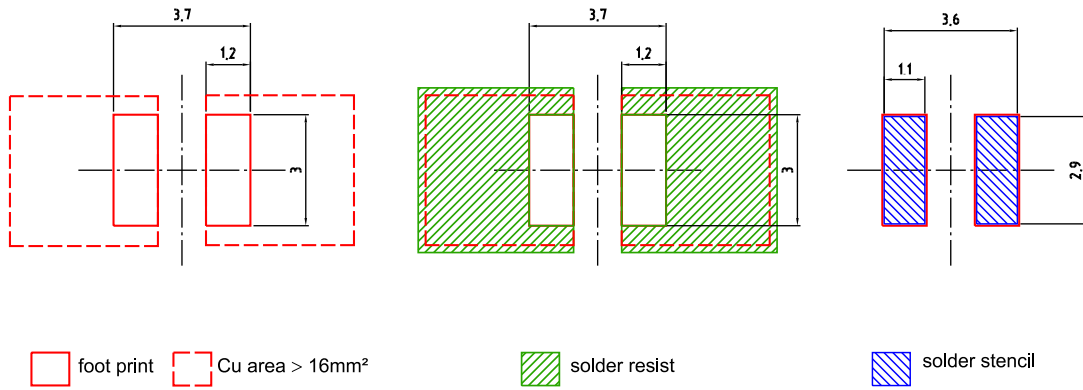

Dimensions in mm.

E062.3010.06 -02



### Reflow Soldering Profile

Product complies to MSL Level 2 acc. to JEDEC J-STD-020D.01

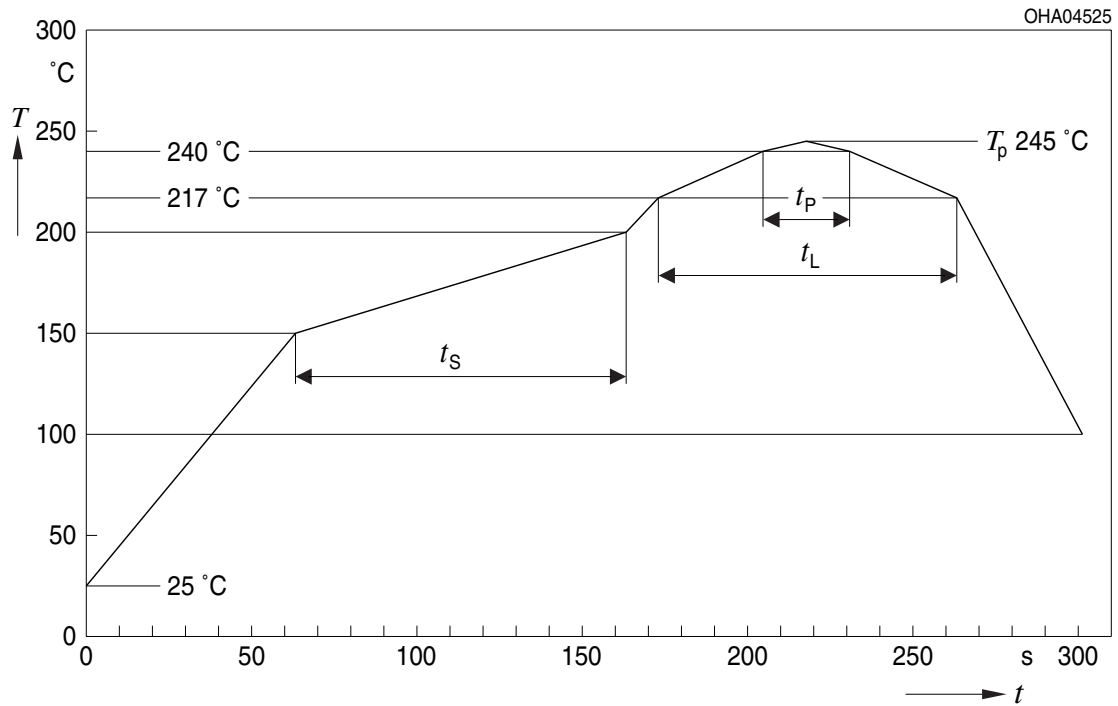

Profil-Charakteristik Profile Feature	Symbol Symbol	Pb-Free (SnAgCu) Assembly			Einheit Unit
		Minimum	Recommendation	Maximum	
Ramp-up Rate to Preheat*) 25 °C to 150 °C			2	3	K/s
Time $t_S$ $T_{Smin}$ to $T_{Smax}$	$t_S$	60	100	120	s
Ramp-up Rate to Peak*) $T_{Smax}$ to $T_P$			2	3	K/s
Liquidus Temperature	$T_L$		217		°C
Time above Liquidus temperature	$t_L$		80	100	s
Peak Temperature	$T_P$		245	250	°C
Time within 5 °C of the specified peak temperature $T_P - 5$ K	$t_P$	10	20	30	s
Ramp-down Rate* $T_P$ to 100 °C			3	4	K/s
Time 25 °C to $T_P$				480	s

All temperatures refer to the center of the package, measured on the top of the component

\* slope calculation  $DT/Dt$ :  $Dt$  max. 5 s; fulfillment for the whole T-range

Taping

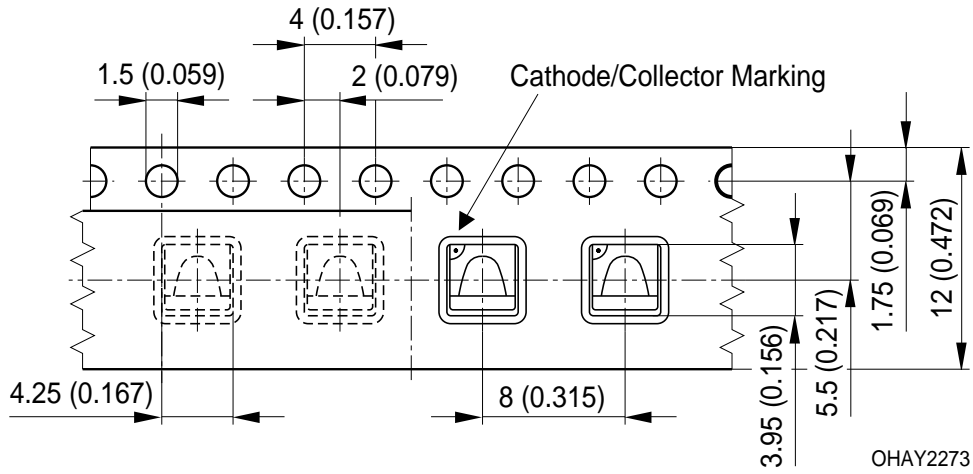

Dimensions in mm (inch).

Tape and Reel

12 mm tape with 2000 pcs. on  $\varnothing$  330 mm reel

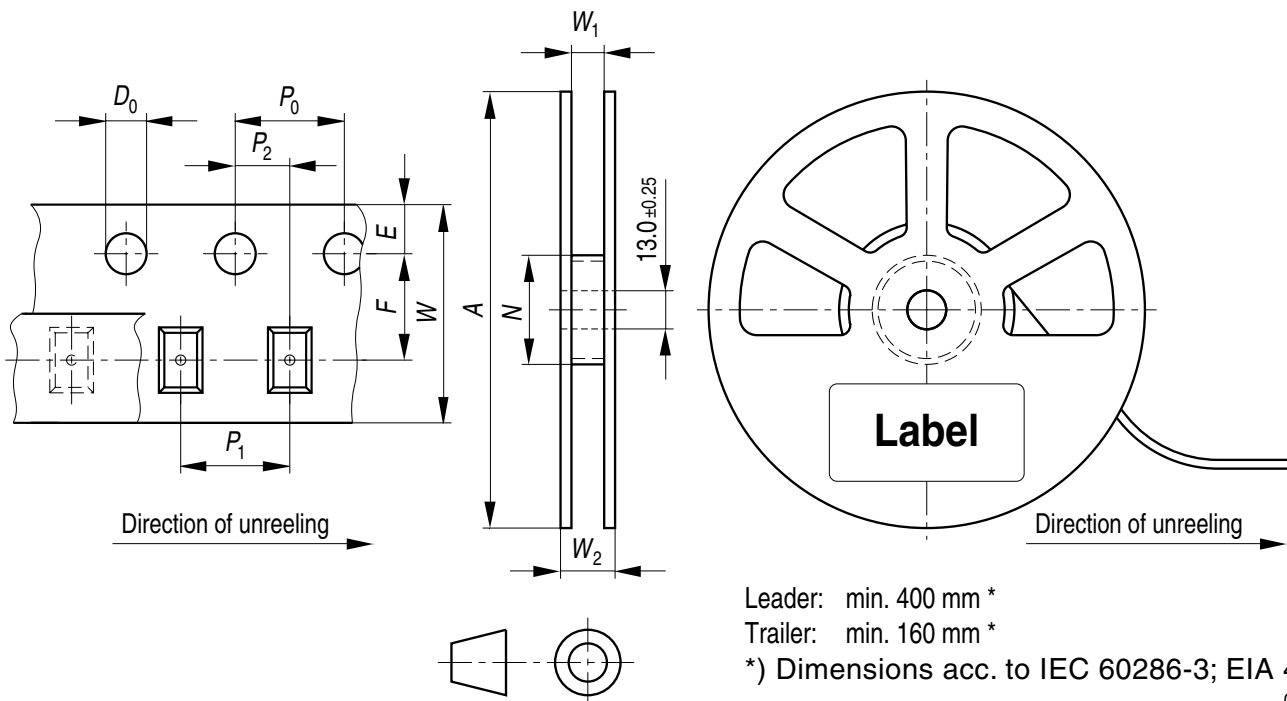

Leader: min. 400 mm \*

Trailer: min. 160 mm \*

\*) Dimensions acc. to IEC 60286-3; EIA 481-D

OHAY0324

## Tape dimensions [mm]

W	P <sub>0</sub>	P <sub>1</sub>	P <sub>2</sub>	D <sub>0</sub>	E	F
12 + 0.3 / - 0.1	4 ± 0.1	4 ± 0.1 or 8 ± 0.1	2 ± 0.05	1.5 ± 0.1	1.75 ± 0.1	5.5 ± 0.05

## Reel dimensions [mm]

A	W	N <sub>min</sub>	W <sub>1</sub>	W <sub>2max</sub>
330	12	60	12.4 + 2	18.4

## Barcode-Product-Label (BPL)

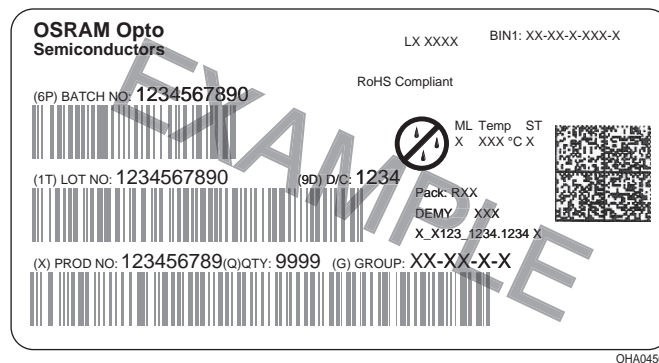

## Dry Packing Process and Materials

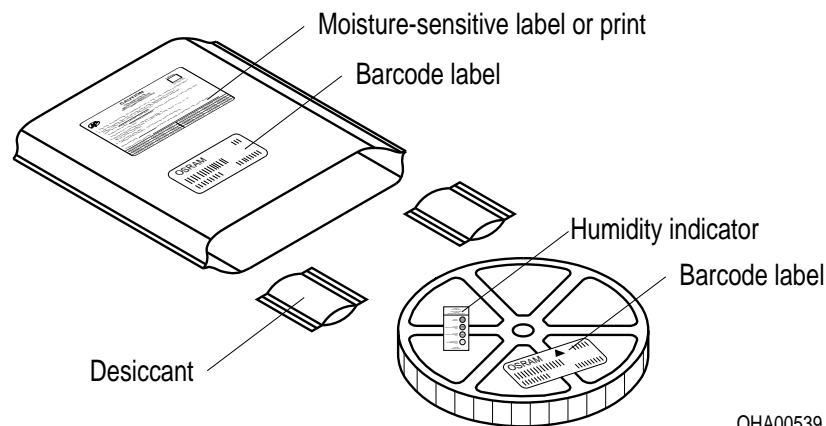

## Note:

Moisture-sensitive product is packed in a dry bag containing desiccant and a humidity card. Regarding dry pack you will find further information in the internet. Here you will also find the normative references like JEDEC.

## Transportation Packing and Materials

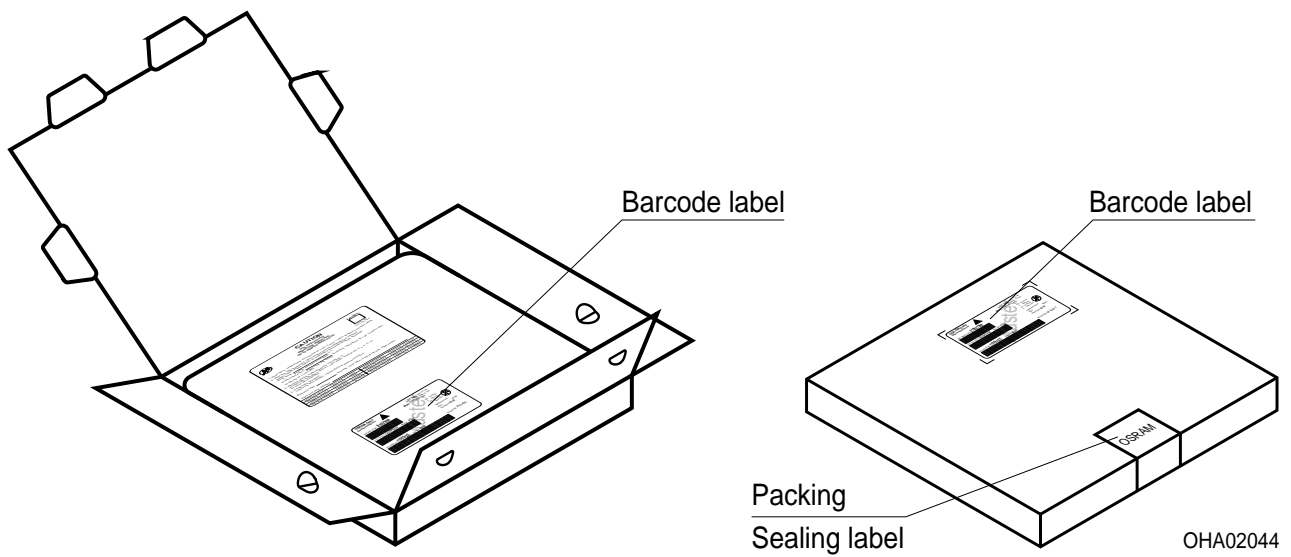

## Dimensions of transportation box in mm

Width	Length	Height
349 ± 5	349 ± 5	33 ± 5

**Disclaimer**

Language english will prevail in case of any discrepancies or deviations between the two language wordings.

**Attention please!**

The information describes the type of component and shall not be considered as assured characteristics.

Terms of delivery and rights to change design reserved. Due to technical requirements components may contain dangerous substances.

For information on the types in question please contact our Sales Organization.

If printed or downloaded, please find the latest version in the Internet.

**Packing**

Please use the recycling operators known to you. We can also help you – get in touch with your nearest sales office.

By agreement we will take packing material back, if it is sorted. You must bear the costs of transport. For packing material that is returned to us unsorted or which we are not obliged to accept, we shall have to invoice you for any costs incurred.

**Components used in life-support devices or systems must be expressly authorized for such purpose!**

Critical components\* may only be used in life-support devices\*\* or systems with the express written approval of OSRAM OS.

\*) A critical component is a component used in a life-support device or system whose failure can reasonably be expected to cause the failure of that life-support device or system, or to affect its safety or the effectiveness of that device or system.

\*\*) Life support devices or systems are intended (a) to be implanted in the human body, or (b) to support and/or maintain and sustain human life. If they fail, it is reasonable to assume that the health and the life of the user may be endangered.

**Glossary**

- <sup>1)</sup> **Typical Values:** Due to the special conditions of the manufacturing processes of LED, the typical data or calculated correlations of technical parameters can only reflect statistical figures. These do not necessarily correspond to the actual parameters of each single product, which could differ from the typical data and calculated correlations or the typical characteristic line. If requested, e.g. because of technical improvements, these typ. data will be changed without any further notice.

**Published by OSRAM Opto Semiconductors GmbH**  
**Leibnizstraße 4, D-93055 Regensburg**  
**www.osram-os.com © All Rights Reserved.**

EU RoHS and China RoHS compliant product



此产品符合欧盟 RoHS 指令的要求；  
按照中国的相关法规和标准，不含有毒有害物质或元素。



Компания «ЭлектроПласт» предлагает заключение долгосрочных отношений при поставках импортных электронных компонентов на взаимовыгодных условиях!

Наши преимущества:

- Оперативные поставки широкого спектра электронных компонентов отечественного и импортного производства напрямую от производителей и с крупнейших мировых складов;
- Поставка более 17-ти миллионов наименований электронных компонентов;
- Поставка сложных, дефицитных, либо снятых с производства позиций;
- Оперативные сроки поставки под заказ (от 5 рабочих дней);
- Экспресс доставка в любую точку России;
- Техническая поддержка проекта, помощь в подборе аналогов, поставка прототипов;
- Система менеджмента качества сертифицирована по Международному стандарту ISO 9001;
- Лицензия ФСБ на осуществление работ с использованием сведений, составляющих государственную тайну;
- Поставка специализированных компонентов (Xilinx, Altera, Analog Devices, Intersil, Interpoint, Microsemi, Aeroflex, Peregrine, Syfer, Eurofarad, Texas Instrument, Miteq, Cobham, E2V, MA-COM, Hittite, Mini-Circuits, General Dynamics и др.);

Помимо этого, одним из направлений компании «ЭлектроПласт» является направление «Источники питания». Мы предлагаем Вам помощь Конструкторского отдела:

- Подбор оптимального решения, техническое обоснование при выборе компонента;
- Подбор аналогов;
- Консультации по применению компонента;
- Поставка образцов и прототипов;
- Техническая поддержка проекта;
- Защита от снятия компонента с производства.



#### Как с нами связаться

**Телефон:** 8 (812) 309 58 32 (многоканальный)

**Факс:** 8 (812) 320-02-42

**Электронная почта:** [org@eplast1.ru](mailto:org@eplast1.ru)

**Адрес:** 198099, г. Санкт-Петербург, ул. Калинина, дом 2, корпус 4, литера А.