

Key Features

- 2.5W Output at 10% THD with a 4Ω Load and 5V Power Supply
- Filterless, Low Quiescent Current and Low EMI
- High Efficiency up to 88%
- Superior Low Noise
- Short Circuit Protection
- Thermal Shutdown
- Few External Components to Save Space and Cost
- MSOP-8, SOP-8, DFN3x3 and DFN2x2 Packages Available
- Pb-Free Package

Applications

- PMP/MP4
- GPS
- Portable Speakers
- Walkie Talkie
- Handsfree phones/Speaker Phones
- Cellular Phones

General Description

The PAM8302A is a 2.5W class-D mono audio amplifier. Its low THD+N feature offers high-quality sound reproduction. The new filterless architecture allows the device to drive speaker directly instead of using low-pass output filters, therefore save system cost and PCB area.

With the same number of external components, the efficiency of the PAM8302A is much better than that of class-AB cousins. It can optimize battery life thus is ideal for portable applications.

The PAM8302A is available in MSOP-8, SOP-8, DFN3x3 and DFN2x2 packages.

Typical Application

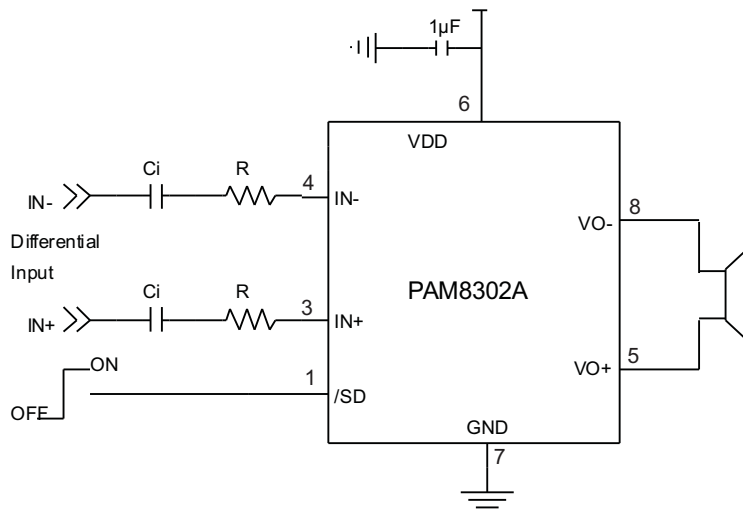

Block Diagram

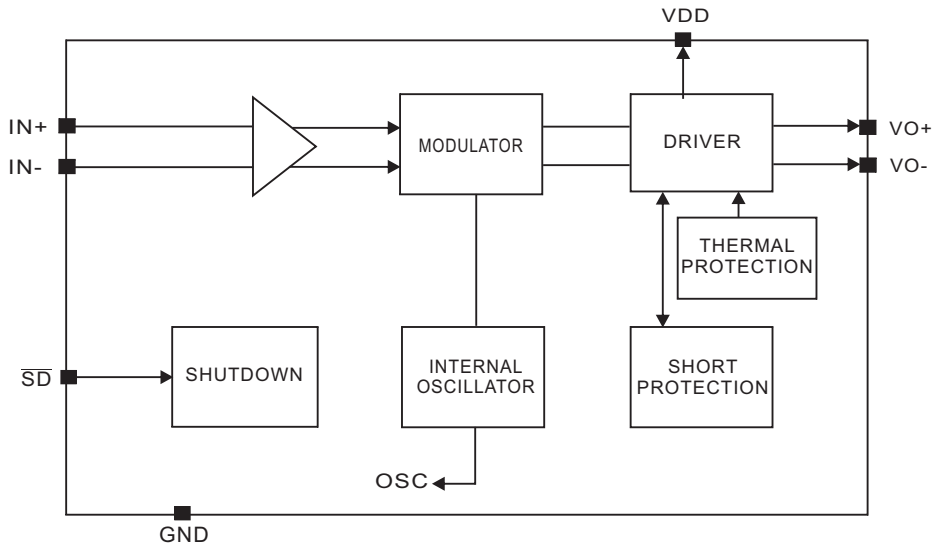

Pin Configuration & Marking Information

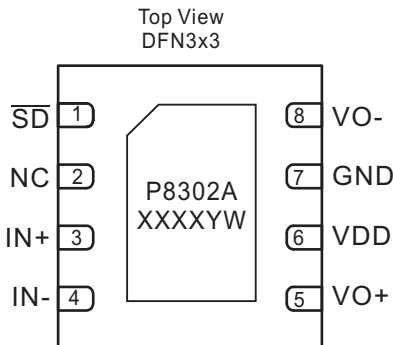
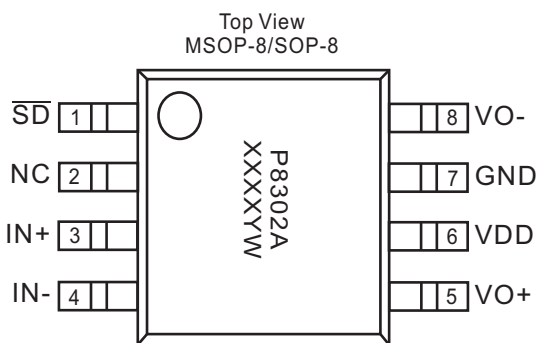

X: Internal Code
Y: Year
W: Week

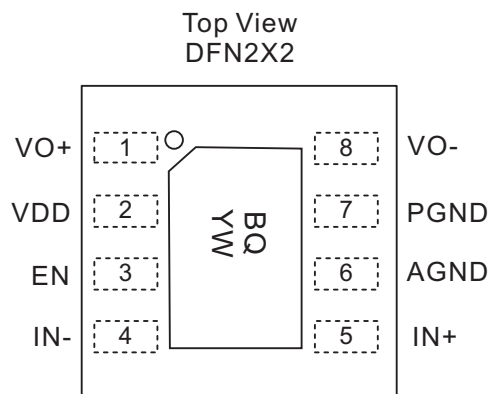

BQ: Product Code
Y: Year
W: Weekly



Absolute Maximum Ratings

These are stress ratings only and functional operation is not implied. Exposure to absolute maximum ratings for prolonged time periods may affect device reliability. All voltages are with respect to ground.

Supply Voltage at no Input Signal.....6.0V	Maximum Junction Temperature.....150°C
Input Voltage.....-0.3V to $V_{DD}+0.3V$	Storage Temperature.....-65°C to 150°C
	Soldering Temperature.....300°C,5sec

Recommended Operating Conditions

Supply voltage Range.....2.5V to 5.5V	Operation Temperature Range..... -40°C to 85°C
	Junction Temperature Range.....-40°C to 125°C

Thermal Information

Parameter	Symbol	Package	Maximum	Unit
Thermal Resistance (Junction to ambient)	θ_{JA}	SOP-8	115	°C/W
		MSOP-8	180	°C/W
		DFN 3x3-8	47.9	°C/W
		DFN 2x2-8	80	°C/W



Electrical Characteristic

$V_{DD}=5V$, Gain = 24dB, $R_L=4\Omega$, $T_A=25^\circ C$, unless otherwise noted.

PARAMETER	SYMBOL	CONDITIONS		MIN	TYP	MAX	UNITS
Supply Voltage Range	V_{DD}			2.5		5.5	V
Quiescent Current	I_Q	No Load			4	8	mA
Shutdown Current	I_{SHDN}	$V_{SHDN}=0V$				1	μA
Output Power	P_O	f=1kHz, $R_L=4\Omega$ THD+N=10%	$V_{DD}=5V$	2.25	2.50		W
			$V_{DD}=3.6V$	1.10	1.25		
		f=1kHz, $R_L=4\Omega$ THD+N=1%	$V_{DD}=5V$	1.80	2.00		
			$V_{DD}=3.6V$	0.86	0.95		
		f=1kHz, $R_L=8\Omega$ THD+N=10%	$V_{DD}=5V$	1.35	1.50		
			$V_{DD}=3.6V$	0.72	0.80		
F=1kHz, $R_L=8\Omega$ THD+N=1%	$V_{DD}=5V$	1.15	1.30				
	$V_{DD}=3.6V$	0.6	0.65				
Peak Efficiency	η	f=1kHz			85	88	%
Total Harmonic Distortion Plus Noise	THD+N	$R_L = 8\Omega$, $P_O=0.1W$, f=1kHz			0.30	0.35	%
		$R_L = 8\Omega$, $P_O=0.5W$, f=1kHz			0.45	0.50	
		$R_L = 4\Omega$, $P_O=0.1W$, f=1kHz			0.35	0.40	
		$R_L = 4\Omega$, $P_O=0.5W$, f=1kHz			0.40	0.45	
Gain	G_v			22.5	24	25.5	dB
Power Supply Ripple Rejection	PSRR	No input, f=1kHz, $V_{pp}=200mV$		45	50		dB
Dynamic Range	Dyn	f=20 to 20kHz		85	90		dB
Signal to Noise Ratio	SNR	f =20 to 20kHz		75	80		dB
Noise	V_n	No A-weighting			180	300	μV
		A-weighting			120	200	
Oscillator Frequency	f_{OSC}			200	250	300	kHz
Drain-Source On-State Resistance	$R_{DS(ON)}$	$I_{DS}=100mA$	P MOSFET		0.45	0.50	Ω
			N MOSFET		0.20	0.25	
\overline{SHDN} Input High	V_{SH}			1.2			V
\overline{SHDN} Input Low	V_{SL}					0.4	V
Over Temperature Protection	OTP	junction temperature		120	135		$^\circ C$
Over Temperature Hysteresis	OTH				30		$^\circ C$

Typical Performance Characteristics

$T_A=25^\circ\text{C}$, unless otherwise noted.

THD+N VS Output Power
 $R_L=8\Omega$, Gain=23dB, $f=1\text{kHz}$

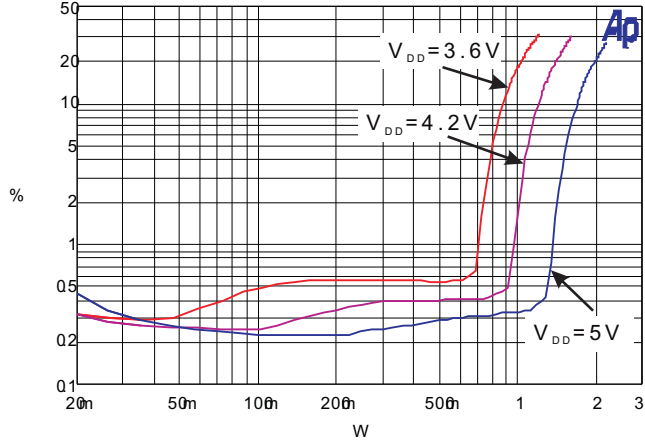

THD+N VS Output Power
 $R_L=4\Omega$, Gain=23dB, $f=1\text{kHz}$

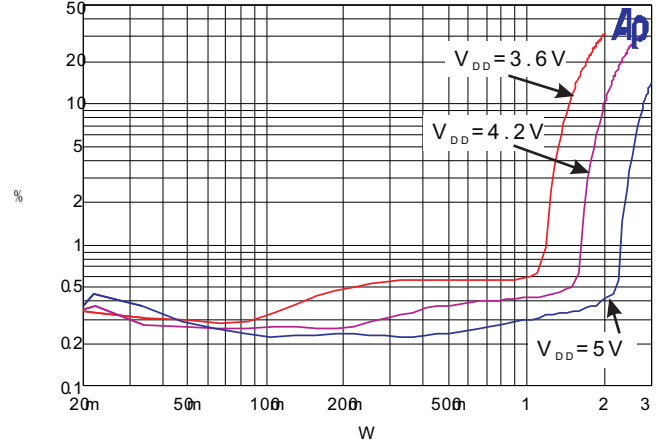

THD+N VS Frequency
 $R_L=8\Omega$, $C_{in}=0.1\mu\text{F}$, Gain=23dB, $V_{DD}=5\text{V}$

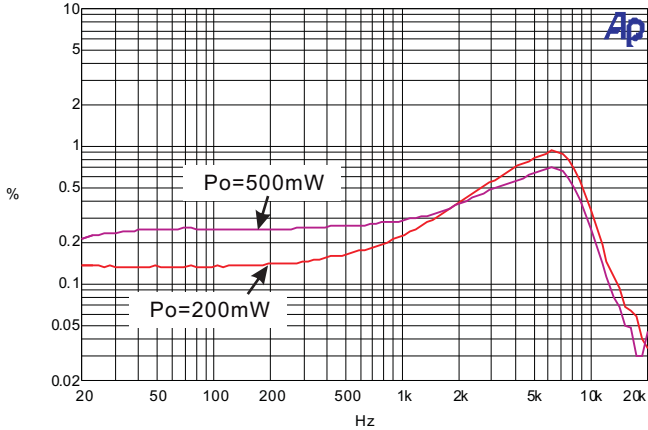

THD+N VS Frequency
 $R_L=8\Omega$, $C_{in}=0.1\mu\text{F}$, Gain=23dB, $V_{DD}=3.6\text{V}$

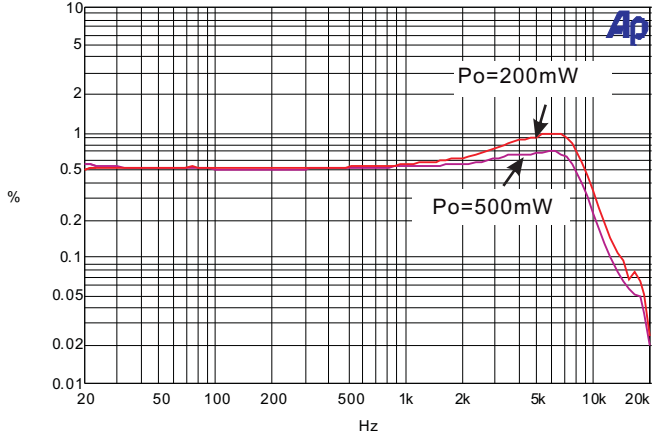

THD+N VS Frequency
 $R_L=4\Omega$, $C_{in}=0.1\mu\text{F}$, Gain=23dB, $V_{DD}=5\text{V}$

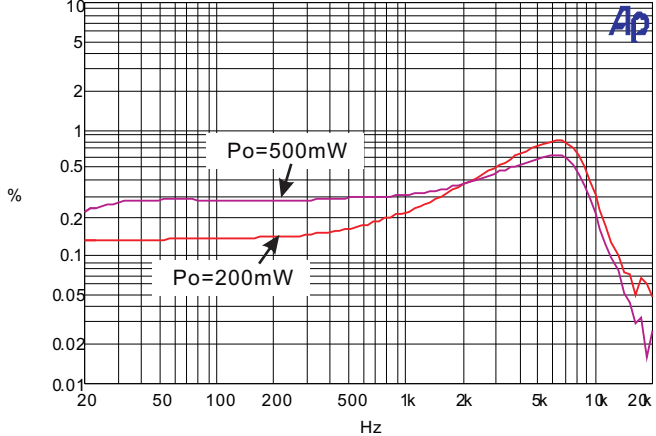

THD+N VS Frequency
 $R_L=4\Omega$, $C_{in}=0.1\mu\text{F}$, Gain=23dB, $V_{DD}=3.6\text{V}$

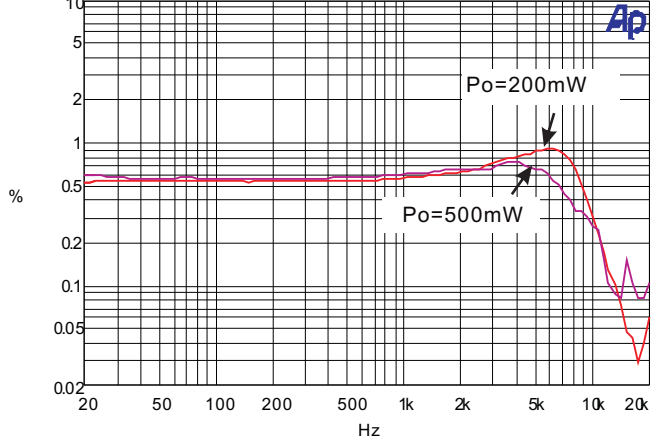



PAM8302A

2.5W Filterless Class-D Mono Audio Amplifier

Typical Performance Characteristics

$T_A=25^{\circ}\text{C}$, unless otherwise noted.

Quiescent Current VS Temperature
No input, No Load, $V_{DD}=5.0\text{V}$

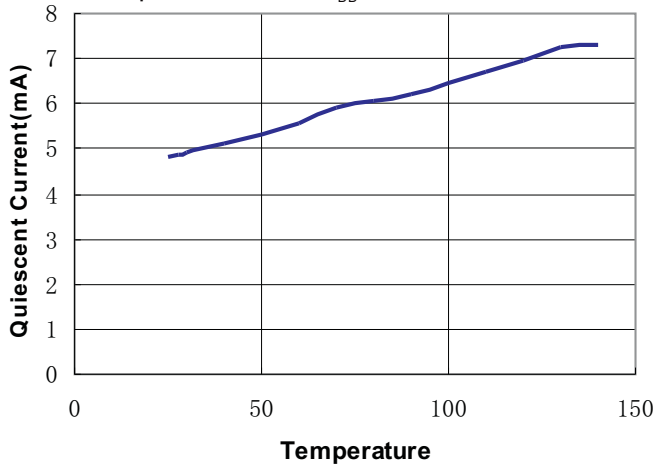

Frequency VS Temperature
No input, No Load, $V_{DD}=5.0\text{V}$

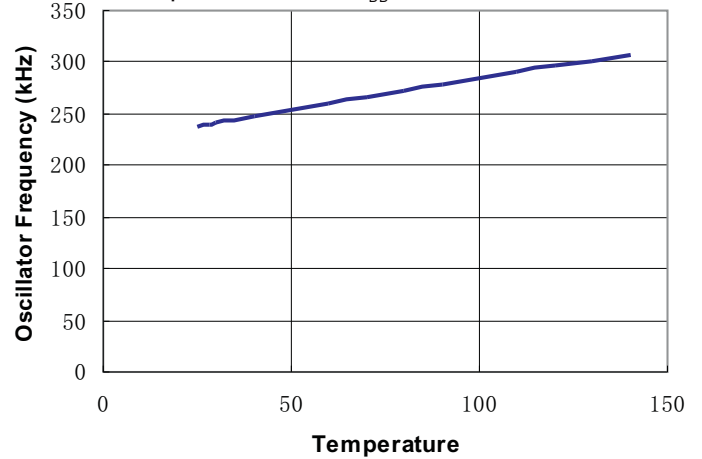

Supply Current VS Output Power
 $R_L=8\Omega+33\mu\text{H}$

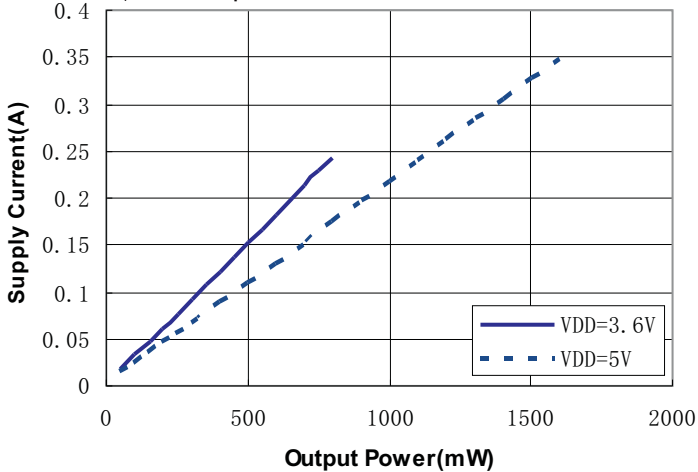

Supply Current VS Output Power
 $V_{DD}=5.0\text{V}$

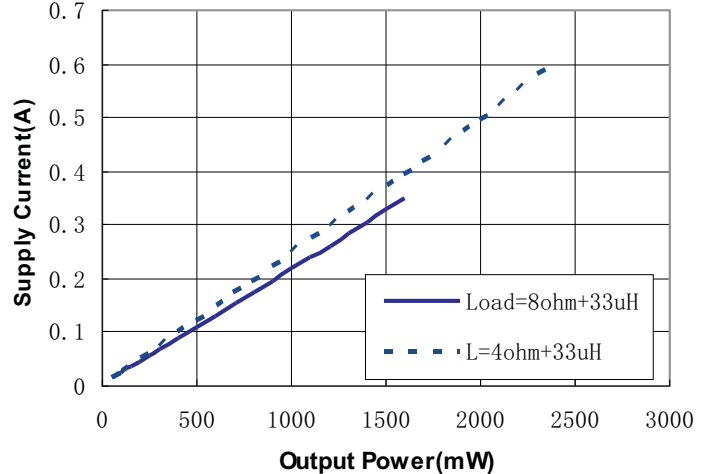

Output Power VS. Supply Voltage
 $R_L=8\Omega$

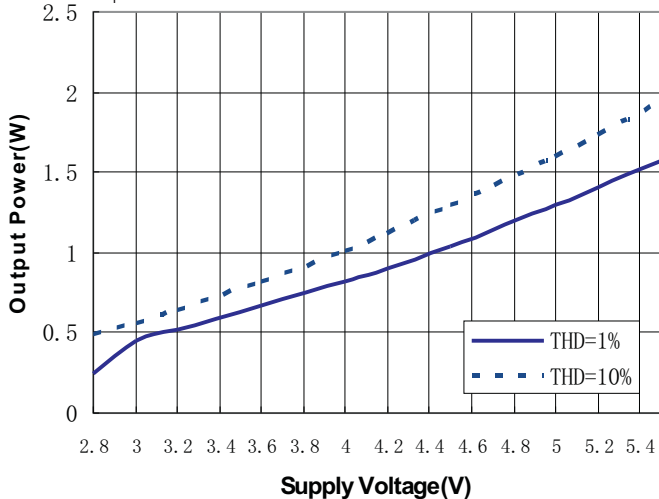

Output Power VS. Supply Voltage
 $R_L=4\Omega$

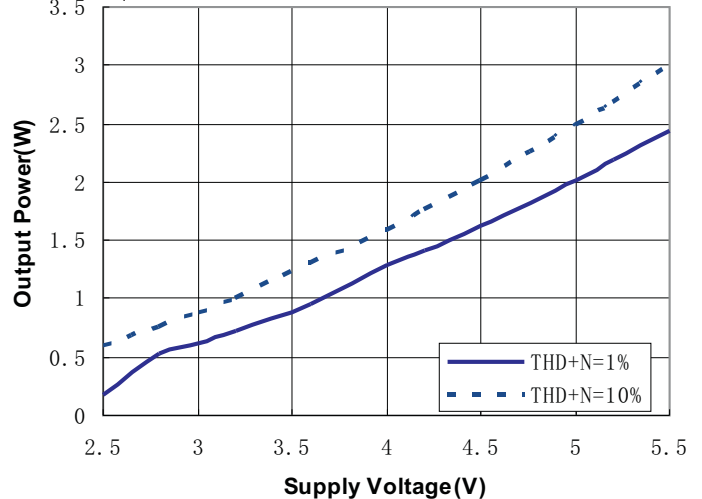



PAM8302A

2.5W Filterless Class-D Mono Audio Amplifier

Typical Performance Characteristics

$T_A=25^{\circ}\text{C}$, unless otherwise noted.

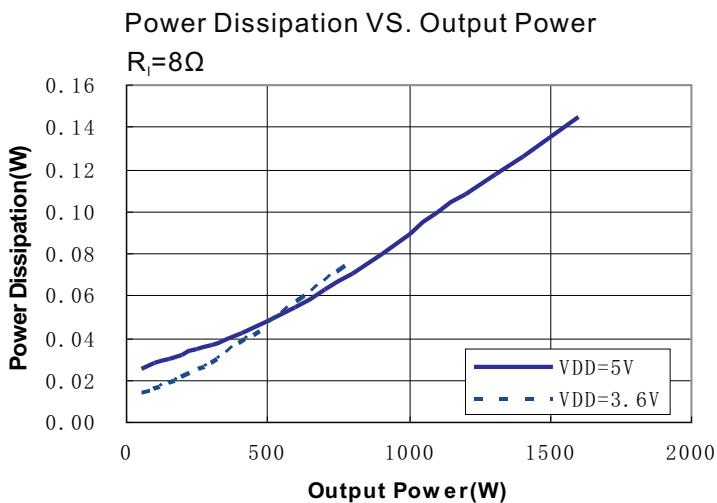
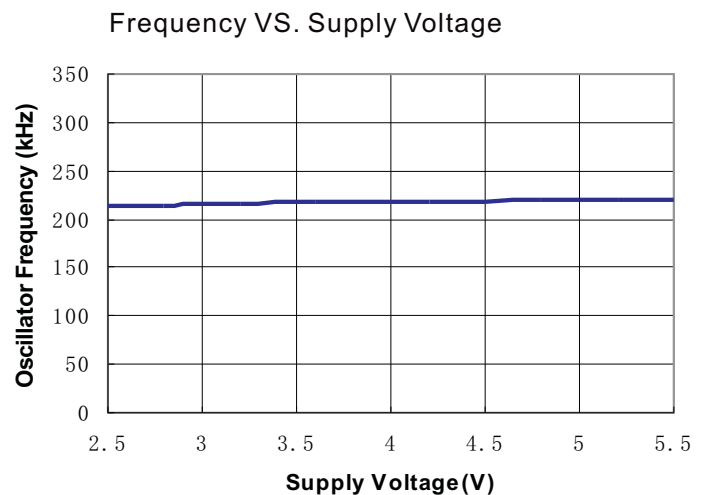
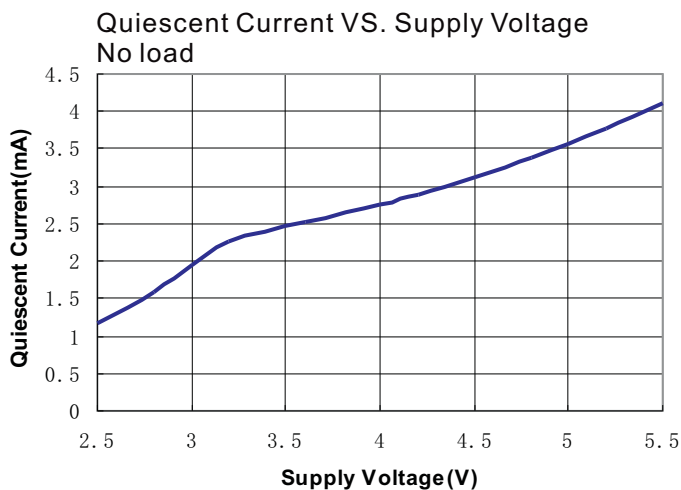
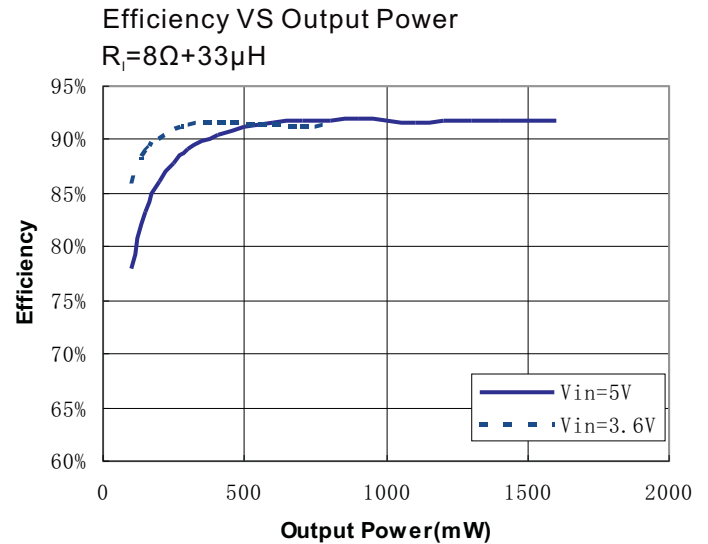
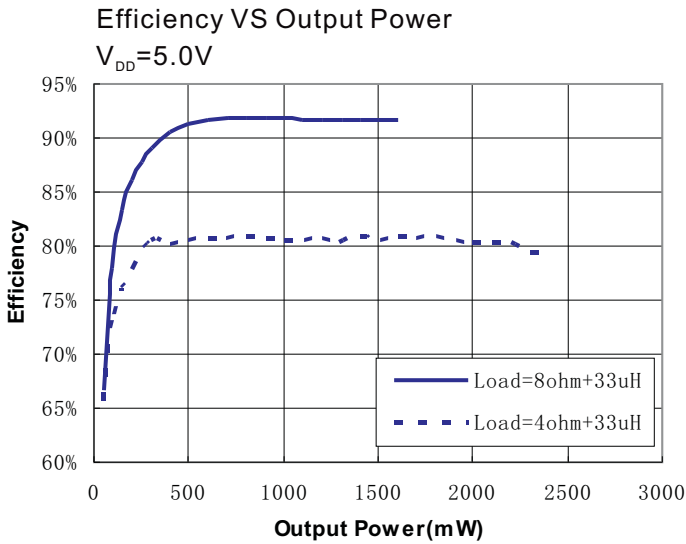

Test Setup for Performance Testing

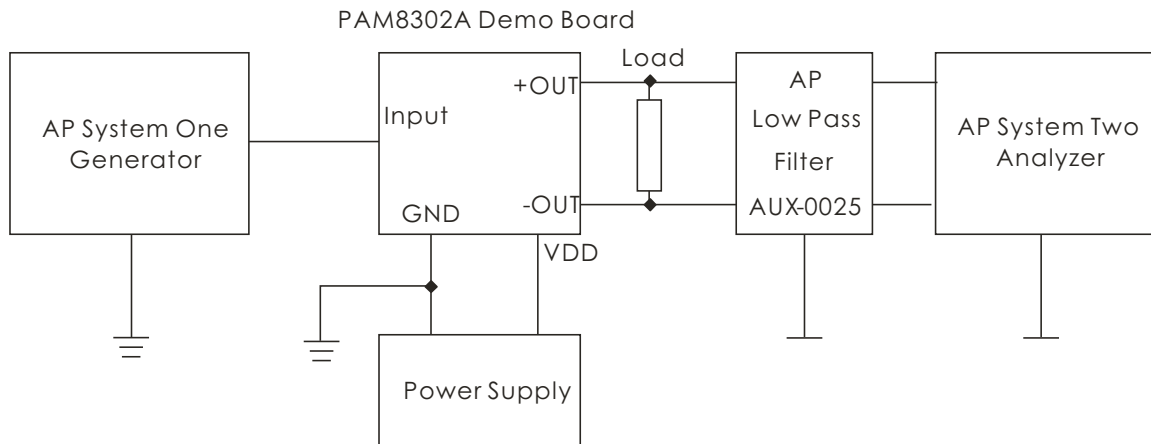

Notes

1. The AP AUX-0025 low pass filter is necessary for every class-D amplifier measurement with AP analyzer.
2. Two 22 μ H inductors are used in series with load resistor to emulate the small speaker for efficiency measurement.

Application Information

Maximum Gain

As shown in block diagram (page 2), the PAM8302A has two internal amplifier stages. The first stage's gain is externally configurable, while the second stage's is internally fixed. The closed-loop gain of the first stage is set by selecting the ratio of R_f to R_i while the second stage's gain is fixed at 2x. The output of amplifier 1 serves as the input to amplifier 2, thus the two amplifiers produce signals identical in magnitude, but different in phase by 180°. Consequently, the differential gain for the IC is

$$A_{vD} = 20 \cdot \log [2 \cdot (R_f/R_i)]$$

The PAM8302A sets maximum $R_f = 80k\Omega$, minimum $R_i = 10k\Omega$, so the maximum closed-gain is 24dB.

Input Capacitors (C_i)

In typical application, an input capacitor, C_i , is required to allow the amplifier to bias input signals to a proper DC level for optimum operation. In this case, C_i and the minimum input impedance R_i (10k internal) form a high pass filter with a corner frequency determined by the following equation:

$$f_c = \frac{1}{2\pi R_i C_i}$$

It is important to choose the value of C_i as it directly affects low frequency performance of the circuit, for example, when an application requires a flat bass response as low as 100Hz. Equation is reconfigured as follows:

$$C_i = \frac{1}{2\pi R_i f_c}$$

As the input resistance is variable, for the C_i value of 0.16 μ F, one should actually choose the C_i within the range of 0.1 μ F to 0.22 μ F. A further consideration for this capacitor is the leakage path from the input source through the input network (R_i , R_f , C_i) to the load. This leakage current creates a DC offset voltage at the input to the amplifier that reduces useful headroom, especially in high gain application. For this reason, a low leakage tantalum or ceramic

capacitor is the best choice. When a polarized capacitor is used, the positive side of the capacitor should face the amplifier input in most applications as the DC level is held at $V_{DD}/2$, which is likely higher than the source DC level. Please note that it is important to confirm the capacitor polarity in the application.

Power Supply Decoupling (C_s)

The PAM8302A is a high-performance CMOS audio amplifier that requires adequate power supply decoupling to ensure the output THD and PSRR as low as possible. Power supply decoupling affects low frequency response. Optimum decoupling is achieved by using two capacitors of different types that target different types of noise on the power supply leads. For higher frequency transients, spikes, or digital hash on the line, a good low equivalent-series-resistance (ESR) ceramic capacitor, typically 1.0 μ F is good, placing it as close as possible to the device VDD terminal. For filtering lower-frequency noise signals, a capacitor of 10 μ F or

larger, closely located to near the audio power amplifier is recommended.

Shutdown Operation

In order to reduce shutdown power consumption, the PAM8302A contains shutdown circuitry for turn off the amplifier. This shutdown feature turns the amplifier off when a logic low is applied on the \overline{SD} pin. By switching the shutdown pin over to GND, the PAM8302A supply current draw will be minimized in idle mode.

For the best power on/off pop performance, the amplifier should be set in the shutdown mode prior to power on/off operation.

Under Voltage Lock-out (UVLO)

The PAM8302A incorporates circuitry to detect low on or off voltage. When the supply voltage drops to 2.1V or below, the PAM8302A goes into a state of shutdown, and the device comes out of its shutdown state and starts to normal operation by reset the power supply or SD pin.

How to Reduce EMI (Electro Magnetic Interference)

A simple solution is to put an additional capacitor 1000 μ F at power supply terminal for power line coupling if the traces from amplifier to speakers are short (<20CM).

Most applications require a ferrite bead filter as shown at Figure 1. The ferrite filter depresses EMI of around 1MHz and higher. When selecting a ferrite bead, choose one with high impedance at high frequencies and low impedance at low frequencies.

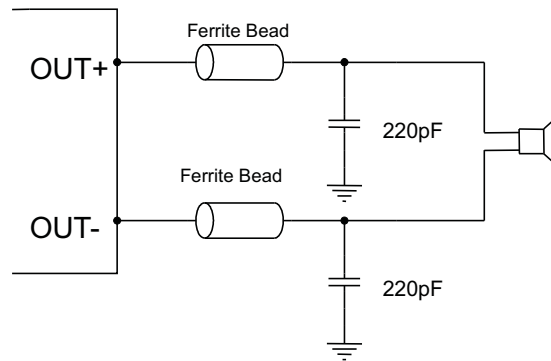
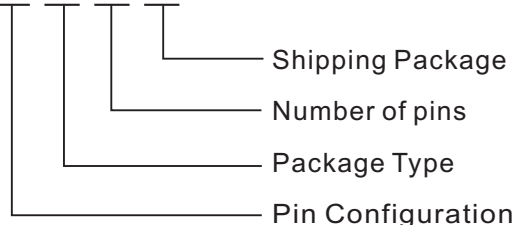

Figure 1: Ferrite Bead Filter to reduce EMI



Ordering Information

PAM8302A X X X X



Pin Configuration		Package Type	Number of pins
A: 1: \overline{SD} 2: NC 3: IN+ 4: IN- 5: VO+ 6: VDD 7: GND 8: VO-	B: 1: VO+ 2: VDD 3: EN 4: IN- 5: IN+ 6: AGND 7: PGND 8: VO-	S: MSOP D: SOP Y: DFN3X3 G: DFN2X2	C: 8

Part Number	Package Type	MOQ/Shipping Package
PAM8302AASCR	MSOP-8	2,500 Units/Tape & Reel
PAM8302AADCR	SOP-8	2,500 Units/Tape & Reel
PAM8302AAYCR	DFN3x3-8	3,000 Units/Tape & Reel
PAM8302ABGCR	DFN2x2-8	3,000 Units/Tape & Reel

Outline Dimensions

MSOP-8

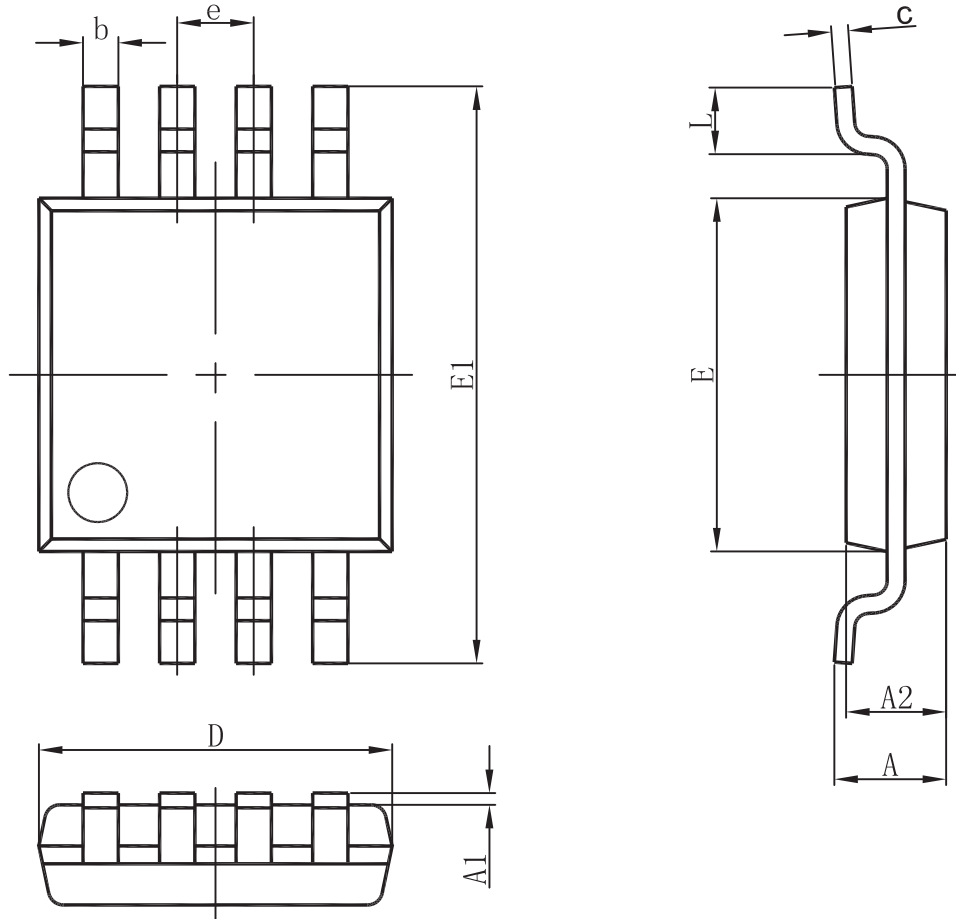

REF	Millimeter	
	Min	Max
A	--	1.10
A1	0.05	0.15
A2	0.78	0.94
b	0.22	0.38
c	0.08	0.23
D	2.90	3.10
E	2.90	3.10
E1	4.75	5.05
e	0.65BSC	
L	0.40	0.70

Outline Dimensions

DFN 3x3

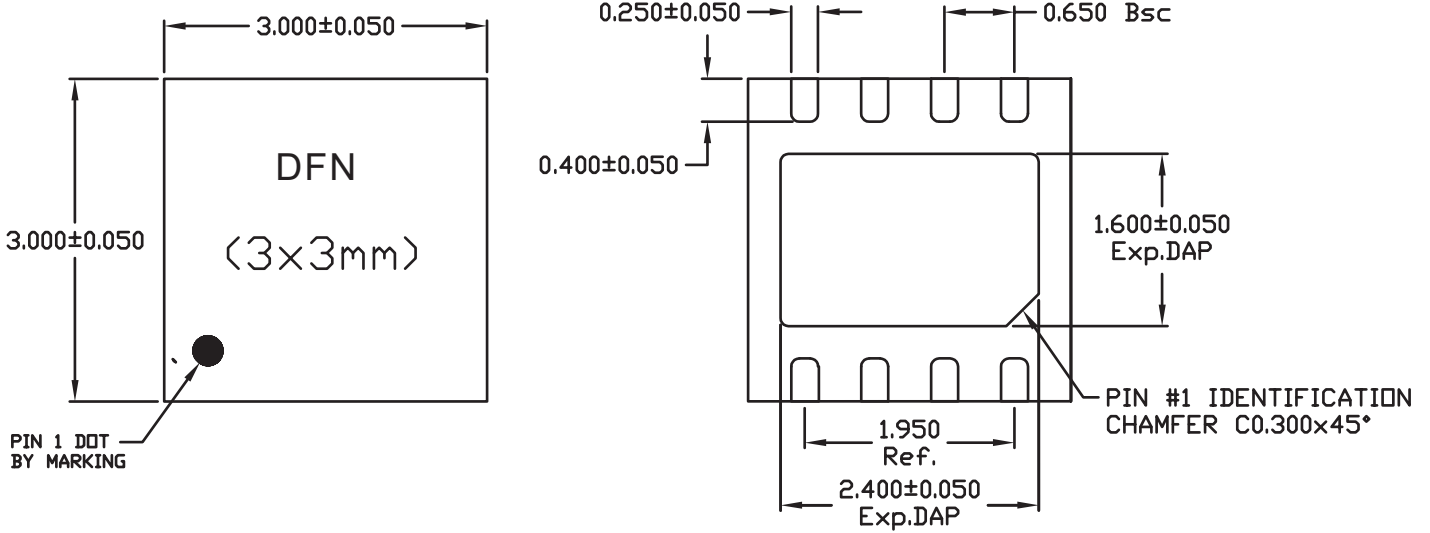

A	MAX.	0.800
	NCM.	0.750
	MIN.	0.700

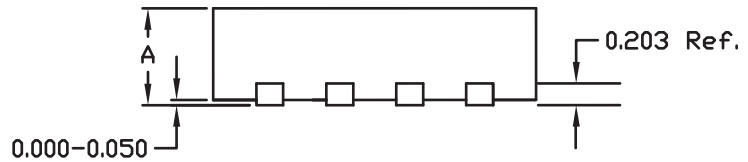

Note: All dimensions are in Millimeters.

Outline Dimensions

SOP-8

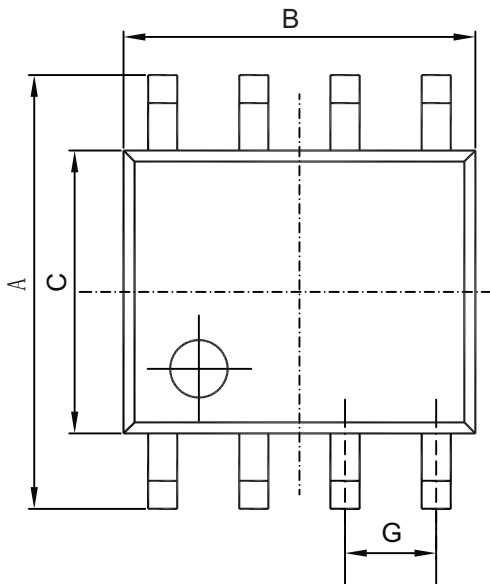

REF	DIMENSIONS	
	Millimeters	
	Min	Max
A	5.80	6.20
B	4.80	5.00
C	3.80	4.00
D	0°	8°
E	0.40	0.90
F	0.19	0.25
M	0.10	0.25
H	0.35	0.49
L	1.35	1.75
J	0.375 REF	
K	45°	
G	1.27 TYP	

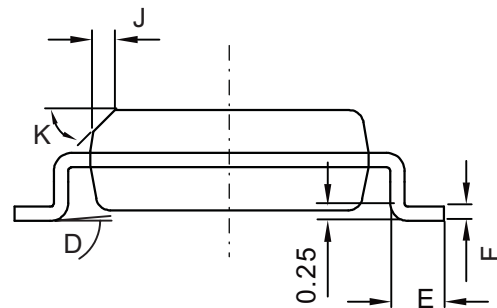
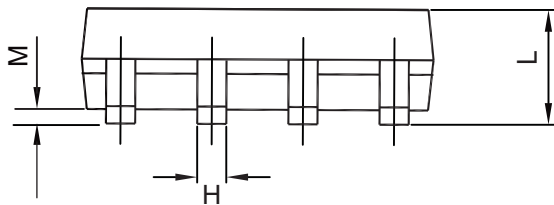

Outline Dimensions

DFN 2x2

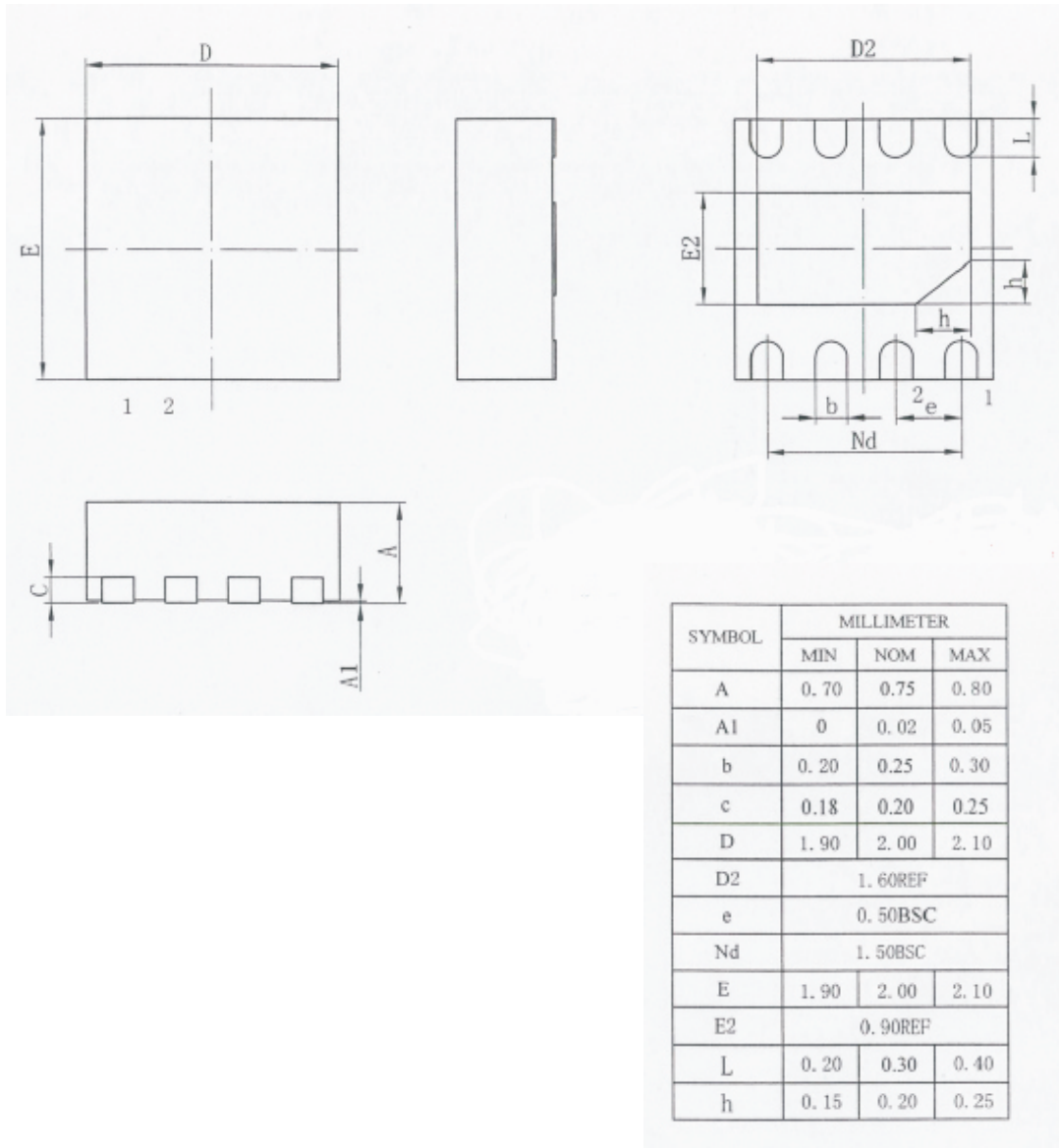



Компания «ЭлектроПласт» предлагает заключение долгосрочных отношений при поставках импортных электронных компонентов на взаимовыгодных условиях!

Наши преимущества:

- Оперативные поставки широкого спектра электронных компонентов отечественного и импортного производства напрямую от производителей и с крупнейших мировых складов;
- Поставка более 17-ти миллионов наименований электронных компонентов;
- Поставка сложных, дефицитных, либо снятых с производства позиций;
- Оперативные сроки поставки под заказ (от 5 рабочих дней);
- Экспресс доставка в любую точку России;
- Техническая поддержка проекта, помощь в подборе аналогов, поставка прототипов;
- Система менеджмента качества сертифицирована по Международному стандарту ISO 9001;
- Лицензия ФСБ на осуществление работ с использованием сведений, составляющих государственную тайну;
- Поставка специализированных компонентов (Xilinx, Altera, Analog Devices, Intersil, Interpoint, Microsemi, Aeroflex, Peregrine, Syfer, Eurofarad, Texas Instrument, Miteq, Cobham, E2V, MA-COM, Hittite, Mini-Circuits, General Dynamics и др.);

Помимо этого, одним из направлений компании «ЭлектроПласт» является направление «Источники питания». Мы предлагаем Вам помощь Конструкторского отдела:

- Подбор оптимального решения, техническое обоснование при выборе компонента;
- Подбор аналогов;
- Консультации по применению компонента;
- Поставка образцов и прототипов;
- Техническая поддержка проекта;
- Защита от снятия компонента с производства.



Как с нами связаться

Телефон: 8 (812) 309 58 32 (многоканальный)

Факс: 8 (812) 320-02-42

Электронная почта: org@eplast1.ru

Адрес: 198099, г. Санкт-Петербург, ул. Калинина, дом 2, корпус 4, литера А.