

## Step-down DC/DC Converter with Synchronous Rectifier

NO.EA-189-160706

### OUTLINE

The RP502x Series are CMOS-based step-down DC/DC converters with synchronous rectifier.

Each of these ICs consists of an oscillator, a reference voltage unit, an error amplifier, a switching control circuit, a soft-start circuit, protection circuits, an UVLO circuit, and switching transistors. By adopting the synchronous rectification with built-in switching transistors, high efficient step-down DC/DC converter can be composed of only an inductor and capacitors.

As protection circuits, the current limit circuit and the latch protection circuit are built into the ICs. The current limit circuit controls the peak current of  $L_x$  at each clock cycle. Latch protection circuit maintains the built-in driver in OFF state if the load current exceeds the limit value for a certain period of time. To cancel the latch protection, disable the ICs with a chip enable circuit and then enable it again or make the power supply voltage lower than UVLO.

The setting voltage for the RP502x Series is the output voltage fixed type with built-in feedback resistance that is adjustable in 0.1V step with the accuracy of  $\pm 1.5\%$  or  $\pm 24\text{mV}$ . The packages for the ICs are WLCSP-6-P2 and DFN1616-6, which enable the high-density mounting. The switching mode for the ICs is selectable from the PWM/VFM auto switching type, which achieves the high efficiency at the light load condition or PWM fixed type, which switches at the fixed frequency.

### FEATURES

- Supply Current ..... Typ. 750 $\mu\text{A}$  (at normal)  
Typ. 180 $\mu\text{A}$  (at light road)
- Input Voltage Range ..... 2.5V to 5.5V ( $V_{\text{OUT}} \geq 1.0\text{V}$ )  
2.5V to 4.5V ( $V_{\text{OUT}} < 1.0\text{V}$ )
- Absolute Maximum Ratings ..... 6.0V
- Output Voltage Range ..... 0.8V to 3.3V (0.1V steps)
- Output Voltage Accuracy .....  $\pm 1.5\%$  ( $V_{\text{OUT}} \geq 1.6\text{V}$ )  
 $\pm 24\text{mV}$  ( $V_{\text{OUT}} < 1.6\text{V}$ )
- Oscillator Frequency ..... Typ. 3.3MHz
- Maximum Duty ..... Min. 100%
- Built-in Driver ON Resistance ..... Typ. Pch. 0.5 $\Omega$ , Nch. 0.5 $\Omega$  ( $V_{\text{IN}} = 3.6\text{V}$ )
- UVLO Detector Threshold ..... Typ. 2.2V
- Soft Start Time ..... Typ. 0.12ms
- $L_x$  Current Limit ..... Typ. 900mA ( $V_{\text{OUT}} \geq 1.2\text{V}$ )  
Typ. 800mA ( $V_{\text{OUT}} < 1.2\text{V}$ )
- Latch type Protection Circuit ..... Typ. 1.5ms
- Chip Enable Function ..... "H" Active
- Packages ..... WLCSP-6-P2, DFN1616-6

### APPLICATIONS

- Power source for battery-powered equipments.
- Power source for hand-held communication equipments, cameras, VCRs, camcorders.
- Power source for HDDs, portable equipments.

**BLOCK DIAGRAMS**

**RP502xxx1B**

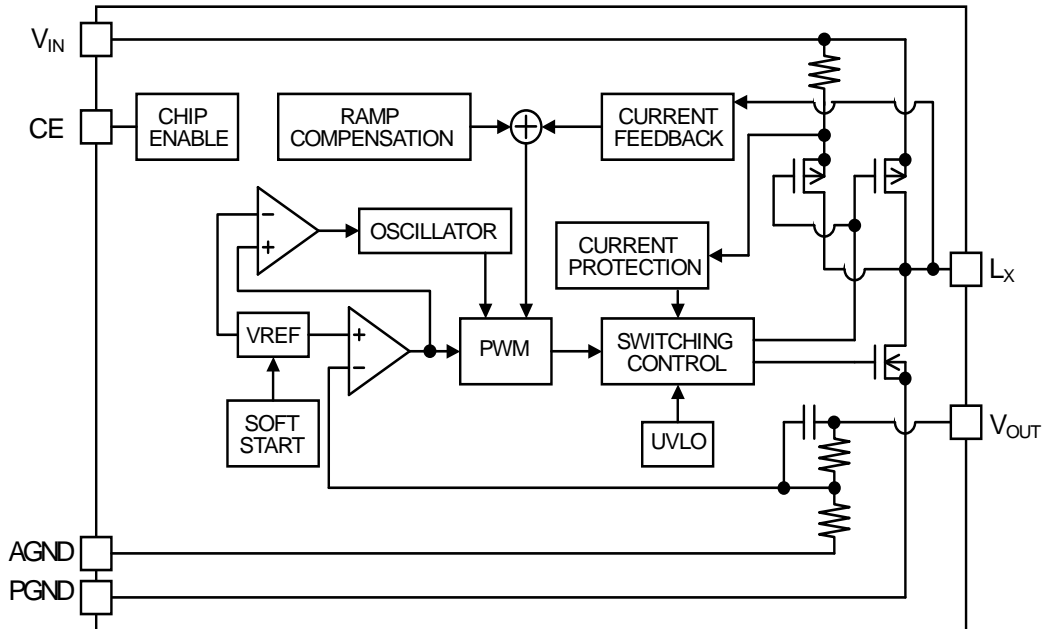

**RP502xxx2B**

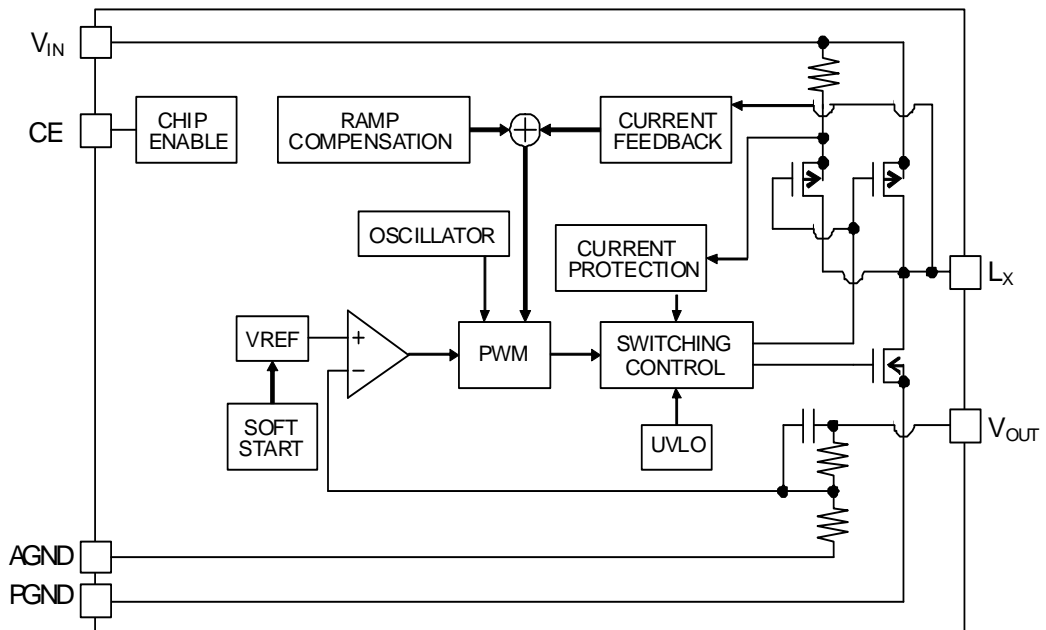

RP502xxx3B

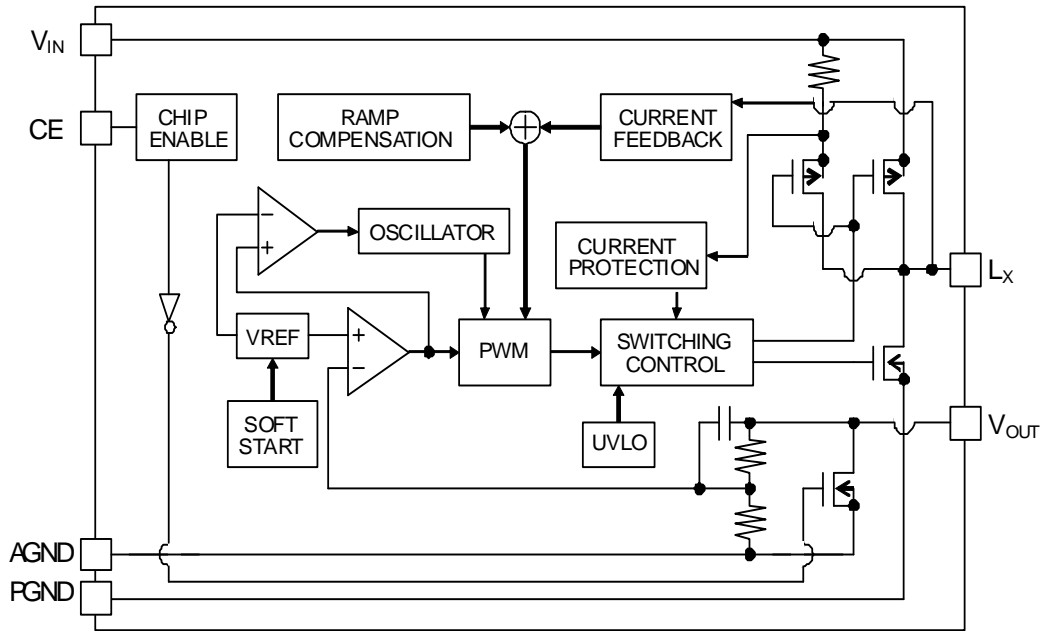

RP502xxx4B

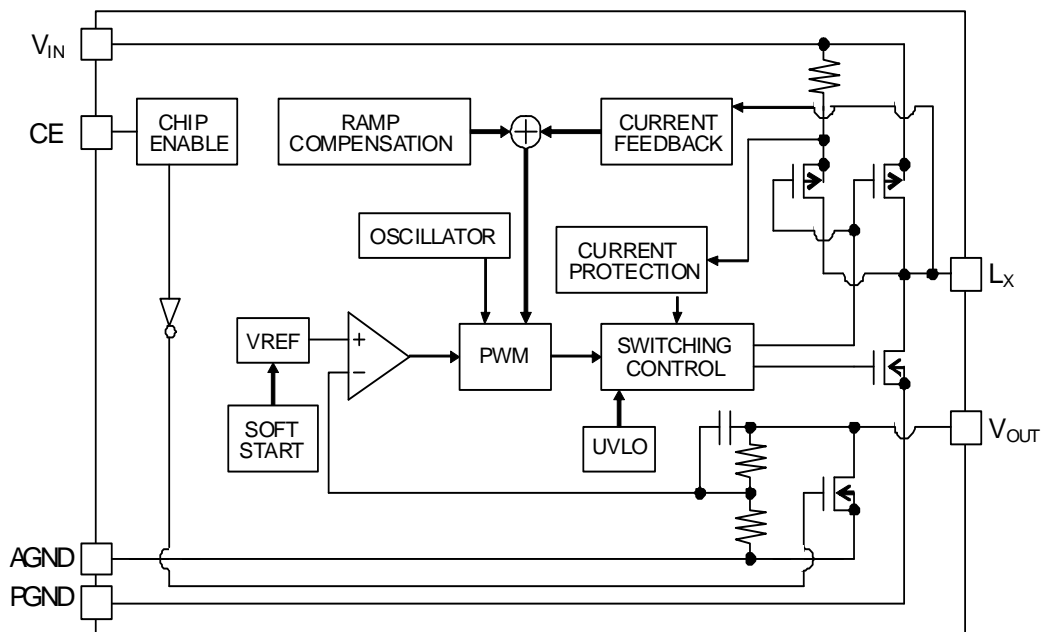

---

**RP502x**

---

NO.EA-189-160706

**SELECTION GUIDE**

In the RP502 Series, output voltage, switching mode, and auto discharge function for the ICs are selectable at the user's request.

Product Name	Package	Quantity per Reel	Pb Free	Halogen Free
RP502Zxx*B-E2-F	WLCSP-6-P2	5,000 pcs	Yes	Yes
RP502Lxx*B-TR	DFN1616-6	5,000 pcs	Yes	Yes

xx: The output voltage can be designated in the range of 0.8V(08) to 3.3V(33) in 0.1V steps\*1.  
(For other voltages, please refer to MARK INFORMATIONS.)

\* : The switching mode and auto discharge function can be designated as shown below.

Code	PWM/VFM auto switching	Auto discharge function
1	Yes	No
2	No	No
3	Yes	Yes
4	No	Yes

Auto-discharge function quickly lowers the output voltage to 0V, when the chip enable signal is switched from the active mode to the standby mode, by releasing the electrical charge accumulated in the external capacitor.

\*1) 0.05V step is also available as a custom code.

## PIN CONFIGURATIONS

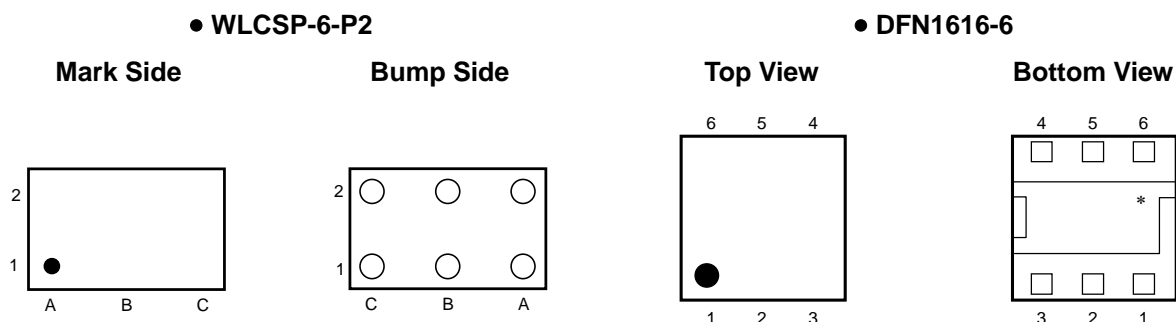

## PIN DESCRIPTIONS

### • WLCSP-6-P2

Pin No	Symbol	Pin Description
A1	$V_{OUT}$	Output Pin
B1	PGND	Ground Pin
C1	$L_X$	$L_X$ Switching Pin
A2	CE	Chip Enable Pin ("H" Active)
B2	AGND	Ground Pin
C2	$V_{IN}$	Input Pin

### • DFN1616-6

Pin No	Symbol	Pin Description
1	CE	Chip Enable Pin ("H" Active)
2	AGND	Ground Pin
3	$V_{IN}$	Input Pin
4	$L_X$	$L_X$ Switching Pin
5	PGND	Ground Pin
6	$V_{OUT}$	Output Pin

\*) Tab is GND level. (They are connected to the reverse side of this IC.)

The tab is better to be connected to the GND, but leaving it open is also acceptable.

**RP502x**

NO.EA-189-160706

**ABSOLUTE MAXIMUM RATINGS**

AGND=PGND=0V

Symbol	Item	Rating	Unit
$V_{IN}$	Input Voltage	-0.3 to 6.0	V
$V_{LX}$	L <sub>x</sub> pin Voltage	-0.3 to $V_{IN} + 0.3$	V
$V_{CE}$	CE Pin Input Voltage	-0.3 to 6.0	V
$V_{OUT}$	Output Voltage	-0.3 to 6.0	V
$I_{LX}$	L <sub>x</sub> Pin Output Current	900	mA
$P_D$	Power Dissipation (WLCSP-6-P2) *	650	mW
	Power Dissipation (DFN1616-6) *	640	
$T_a$	Operating Temperature Range	-40 to 85	°C
$T_{stg}$	Storage Temperature Range	-55 to 125	°C

\*) For Power Dissipation, please refer to PACKAGE INFORMATION.

**ABSOLUTE MAXIMUM RATINGS**

Electronic and mechanical stress momentarily exceeded absolute maximum ratings may cause the permanent damages and may degrade the lifetime and safety for both device and system using the device in the field. The functional operation at or over these absolute maximum ratings is not assured.

**RECOMMENDED OPERATING CONDITIONS (ELECTRICAL CHARACTERISTICS)**

All of electronic equipment should be designed that the mounted semiconductor devices operate within the recommended operating conditions. The semiconductor devices cannot operate normally over the recommended operating conditions, even if when they are used over such conditions by momentary electronic noise or surge. And the semiconductor devices may receive serious damage when they continue to operate over the recommended operating conditions.

## ELECTRICAL CHARACTERISTICS

## ● RP502xxxxB

(Ta=25°C)

Symbol	Item	Conditions	MIN.	TYP.	MAX.	Unit
V <sub>IN</sub>	Operating Input Voltage	V <sub>OUT</sub> ≥ 1.0	2.5		5.5	V
		V <sub>OUT</sub> < 1.0	2.5		4.5	
V <sub>OUT</sub>	Output Voltage	V <sub>IN</sub> = V <sub>CE</sub> = 3.6V or V <sub>SET</sub> + 1V	V <sub>OUT</sub> ≥ 1.6	-1.5%	+1.5%	V
			V <sub>OUT</sub> < 1.6	-0.024	+0.024	
ΔV <sub>OUT</sub> /ΔTa	Output Voltage Temperature Coefficient	-40°C ≤ Ta ≤ 85°C		±100		ppm/ °C
fosc	Oscillator Frequency	V <sub>IN</sub> = V <sub>CE</sub> = 3.6V or V <sub>SET</sub> + 1V	2.64	3.3	3.96	MHz
I <sub>DD1</sub>	Supply Current 1	V <sub>IN</sub> = V <sub>CE</sub> = 5.5V, V <sub>OUT</sub> = 0V		750	900	μA
I <sub>DD2</sub>	Supply Current 2	V <sub>IN</sub> = V <sub>CE</sub> = V <sub>OUT</sub> = 5.5V	PWM/VFM	180	240	μA
			PWM fixed	750	900	
I <sub>standby</sub>	Standby Current	V <sub>IN</sub> = 5.5V, V <sub>CE</sub> = 0V		0	5	μA
I <sub>CEH</sub>	CE "H" Input Current	V <sub>IN</sub> = V <sub>CE</sub> = 5.5V	-1	0	1	μA
I <sub>CEL</sub>	CE "L" Input Current	V <sub>IN</sub> = 5.5V, V <sub>CE</sub> = 0V	-1	0	1	μA
I <sub>VOUTH</sub>	V <sub>OUT</sub> "H" Input Current*1	V <sub>IN</sub> = V <sub>OUT</sub> = 5.5V, V <sub>CE</sub> = 0V	-1	0	1	μA
I <sub>VOUTL</sub>	V <sub>OUT</sub> "L" Input Current	V <sub>IN</sub> = 5.5V, V <sub>CE</sub> = V <sub>OUT</sub> = 0V	-1	0	1	μA
R <sub>LOW</sub>	Low Output Nch Tr. ON Resistance*2	V <sub>IN</sub> = 3.6V, V <sub>CE</sub> = 0V		40		Ω
I <sub>LXLEAKH</sub>	Lx Leakage Current "H"	V <sub>IN</sub> = V <sub>LX</sub> = 5.5V, V <sub>CE</sub> = 0V	-1	0	1	μA
I <sub>LXLEAKL</sub>	Lx Leakage Current "L"	V <sub>IN</sub> = 5.5V, V <sub>CE</sub> = V <sub>LX</sub> = 0V	-5	0	5	μA
V <sub>CEH</sub>	CE Input Voltage "H"	V <sub>IN</sub> = 5.5V	1.0			V
V <sub>CEL</sub>	CE Input Voltage "L"	V <sub>IN</sub> = 2.5V			0.4	V
R <sub>ONP</sub>	ON Resistance of Pch Tr.	V <sub>IN</sub> = 3.6V, I <sub>LX</sub> = -100mA		0.5		Ω
R <sub>ONN</sub>	ON Resistance of Nch Tr.	V <sub>IN</sub> = 3.6V, I <sub>LX</sub> = -100mA		0.5		Ω
Maxduty	Maximum Duty		100			%
t <sub>START</sub>	Soft-start Time	V <sub>IN</sub> = V <sub>CE</sub> = 3.6V or V <sub>SET</sub> + 1V		120	150	μs
I <sub>LXLIM</sub>	Lx Current Limit	V <sub>IN</sub> = V <sub>CE</sub> = 3.6V or V <sub>SET</sub> + 1V	V <sub>OUT</sub> ≥ 1.2	600	900	mA
			V <sub>OUT</sub> < 1.2	500	800	
t <sub>PROT</sub>	Protection Delay Time	V <sub>IN</sub> = V <sub>CE</sub> = 3.6V or V <sub>SET</sub> + 1V	0.5	1.5	5	ms
V <sub>UVLO1</sub>	UVLO Detector Threshold	V <sub>IN</sub> = V <sub>CE</sub>	2.1	2.2	2.3	V
V <sub>UVLO2</sub>	UVLO Released Voltage	V <sub>IN</sub> = V <sub>CE</sub>	2.2	2.3	2.4	V

Test circuit is "OPEN LOOP" and AGND=PGND=0V unless otherwise noted.

\*1) without auto discharge function

\*2) with auto discharge function

# TEST CIRCUITS

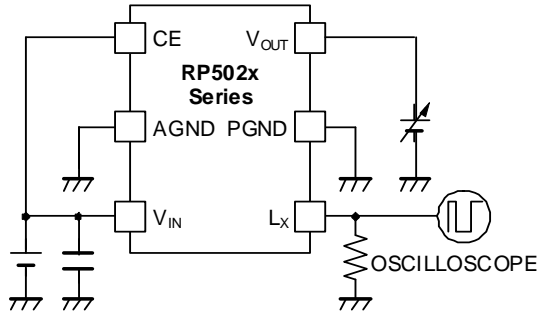

Output Voltage

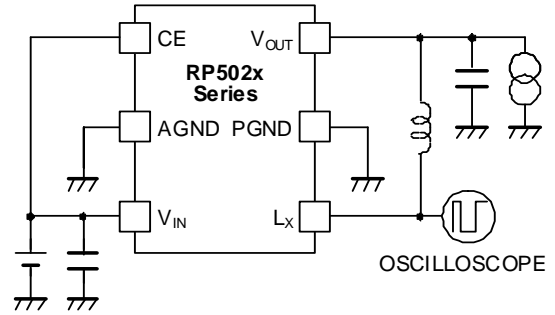

Oscillator Frequency

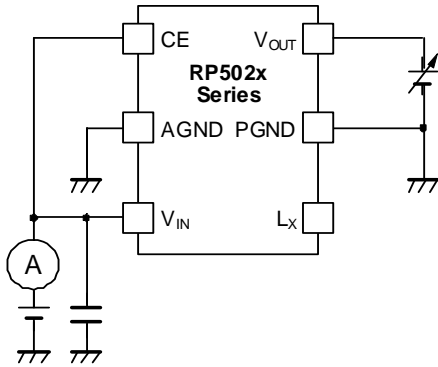

Supply Current 1,2

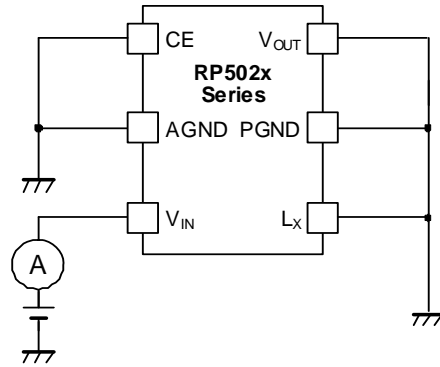

Standby Current

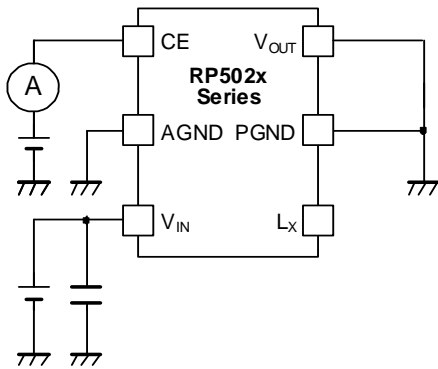

CE "H"/"L" Input Current

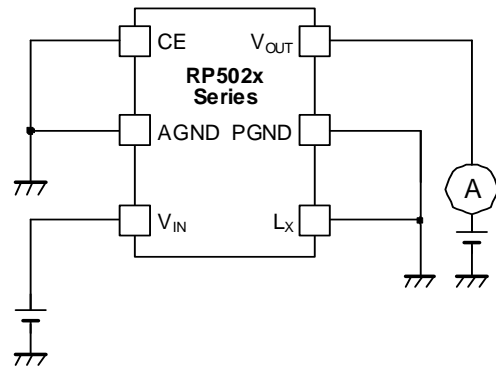

V<sub>OUT</sub> "H"/"L" Current



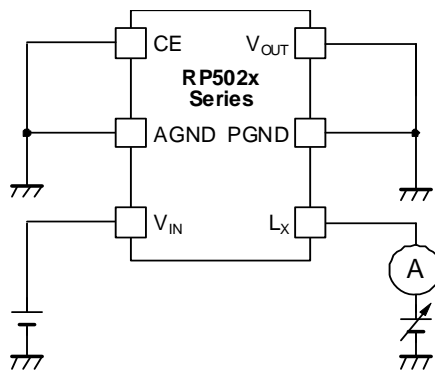

L<sub>X</sub> Leakage Current

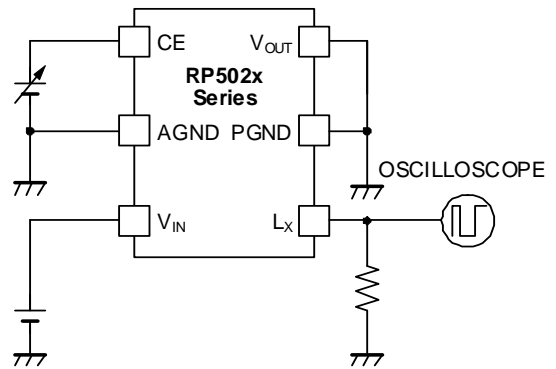

CE Input Voltage

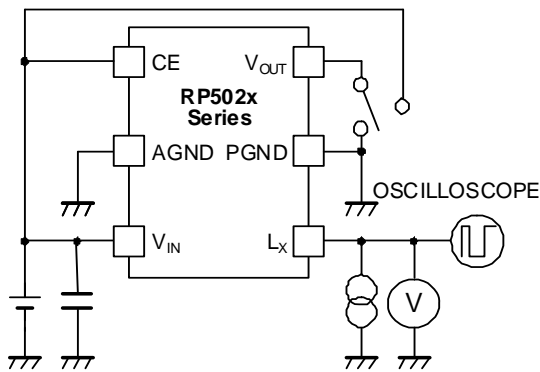

Pch • Nch Tr. ON resistance /  
Output Delay for Protection / L<sub>X</sub> Current limit

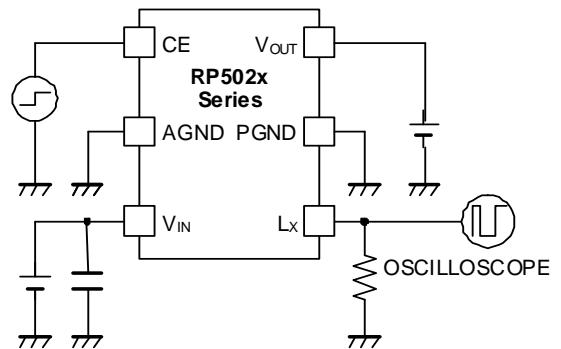

Soft-start Time

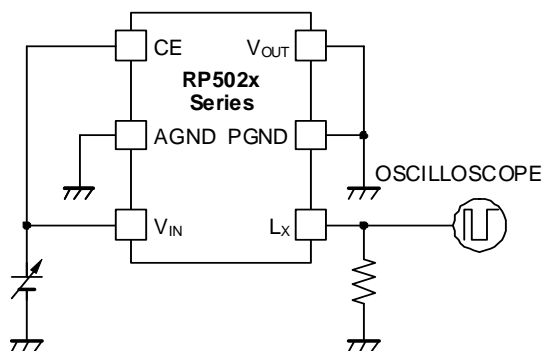

UVLO Detector Threshold • Released Voltage

TYPICAL APPLICATION

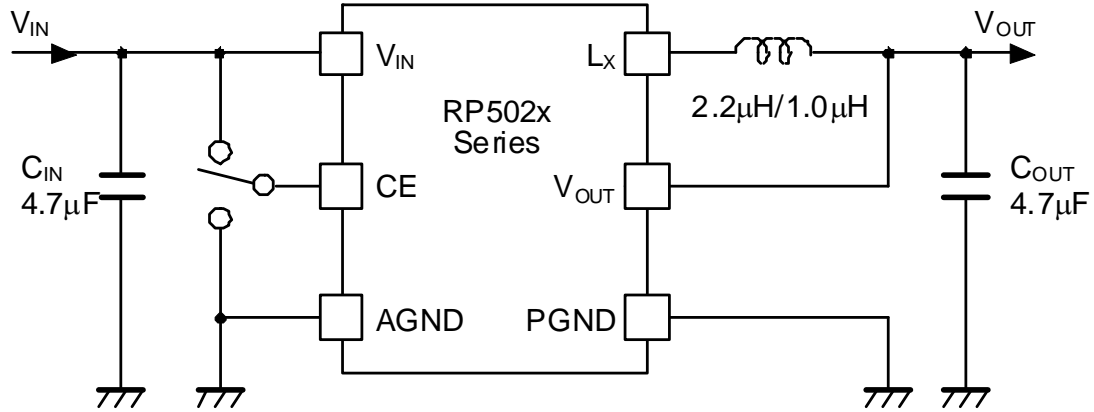

Symbol	Parts Recommendation		
C <sub>IN</sub>	4.7µF	Ceramic	JMK107BJ475MA (TAIYO YUDEN)
C <sub>OUT</sub>	4.7µF	Ceramic	JMK107BJ475MA (TAIYO YUDEN)
L	2.2µH	NR 3010T 2R2M (TAIYO YUDEN) , 1.0µH MIPS 2520 D1R0 (FDK)	

## TECHNICAL NOTES

When using the R502x Series, consider the following points:

- Set AGND in the same level as PGND.
  - Set external components such as an inductor,  $C_{IN}$ , and  $C_{OUT}$  as close as possible to the ICs.  $V_{IN}$ ,  $C_{IN}$  and PGND have to be wired as close as possible. If the impedances of  $V_{IN}$  line and PGND line are high, the switching current will fluctuate the electric potential of the inside the ICs. As a result, the operation may become unstable. The impedances of power supply line and PGND line must be as low as possible. Please note that a large current caused by the switching current flows into  $V_{IN}$ , PGND, Inductor,  $L_X$ , and  $V_{OUT}$ . Separate the wiring between  $V_{OUT}$  pin and inductor from the wiring of load.
  - For  $C_{IN}$ , use a ceramic capacitor with a low ESR. The recommended condenser capacity for  $C_{IN}$  is 4.7 $\mu$ F or more. Also, the recommended condenser capacity for  $C_{OUT}$  is 4.7 $\mu$ F.
  - Choose an inductor from the range of 1.0 to 2.2 $\mu$ H. The internal phase compensation has been determined based on the above-mentioned inductor value and the  $C_{OUT}$  value. For stable operation, these conditions are necessary. Choose an inductor that is low DC resistance, has enough permissive current, and is strong against magnetic saturation. Decide the inductance value with consideration of the load current under the condition of use. If the inductance value is low, the peak value of  $L_X$  current may increase along with the increase of the load current. As a result, the peak value of  $L_X$  may reach to the "L<sub>X</sub> Limit Current" and may trigger the overcurrent protection circuit.
  - Please note that overcurrent protection circuit may be affected by self-heating and heat radiation environment.
- \* The performance of power source circuits using these ICs largely depends upon the peripheral circuits. Pay attention to the setting of the peripheral components. In particular, when designing the peripheral circuit, the constant values (voltage, current and power) for each part, PCB pattern and the ICs should not be exceeded.

## Operation of step-down DC/DC converter and Output Current

The step-down DC/DC converter charges energy in the inductor when the Lx transistor is turned on, and discharges the energy when the Lx transistor is turned off. The step-down DC/DC converter also controls with the less energy loss and supplies the lower output voltage than the input voltage. The operation of the DC/DC converter will be explained with the following diagrams:

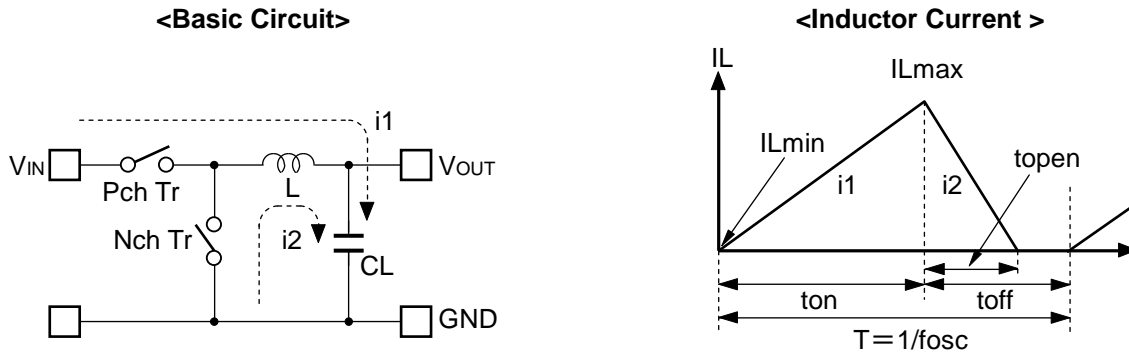

- Step 1: Pch Tr. turns on and current  $I_L (=i_1)$  flows. Then, L and CL are charged with energy. At this moment,  $I_L (=i_1)$  increases from  $I_{Lmin} (=0)$  to  $I_{Lmax}$  in proportion to the On-time period ( $t_{on}$ ) of Pch Tr.
- Step 2: When Pch Tr. turns off, Synchronous rectifier Nch Tr. turns on and  $I_L (=i_2)$  flows in order to maintain  $I_L$  at  $I_{Lmax}$ .
- Step 3:  $I_L (=i_2)$  starts to decrease gradually when  $t_{open}$  time period starts.  $I_L$  reaches to  $I_{Lmin}$  ( $I_L = I_{Lmin} = 0$ ) when  $t_{open}$  time period ends and then Nch Tr. turns off. In the continuous mode,  $t_{off}$  time period runs out before  $I_L$  becomes  $I_{Lmin}$  ( $I_L = I_{Lmin} = 0$ ). The next cycle starts. Pch Tr. turns on and Nch Tr. turns off. Since  $t_{off}$  time period runs out before  $I_L$  becomes  $I_{Lmin}$  ( $I_L = I_{Lmin} = 0$ ),  $I_{Lmin} (>0)$  is still remaining. In this case,  $I_L$  starts increasing from  $I_{Lmin} (>0)$ .

In the case of PWM control system, the output voltage is maintained constant by keeping the switching time ( $f_{osc}$ ) per unit constant, and by controlling the On-time period ( $t_{on}$ ).

When the step-down operation is constant and stable, as shown in the above “Inductor Current”, the maximum inductor current ( $I_{Lmax}$ ) will be same as the on-time period of Pch Tr. ( $t_{on}$ ) and the minimum inductor current ( $I_{Lmin}$ ) will be same as the on-time period of Pch Tr. ( $t_{off}$ ).

The difference between  $I_{Lmax}$  and  $I_{Lmin}$  is described as  $\Delta I$ :

$$\Delta I = I_{Lmax} - I_{Lmin} = V_{OUT} \times t_{open} / L = (V_{IN} - V_{OUT}) \times t_{on} / L \dots\dots\dots \text{Equation 1}$$

Wherein,

$$T = 1 / f_{osc} = t_{on} + t_{off}$$

$$\text{duty (\%)} = t_{on} / T \times 100 = t_{on} \times f_{osc} \times 100$$

$$t_{open} \leq t_{off}$$

In Equation 1, “ $V_{OUT} \times t_{open} / L$ ” shows the amount of current change at the on-time. “ $(V_{IN} - V_{OUT}) \times t_{on} / L$ ” shows the amount of current change at the off-time”.

### Discontinuous mode and Continuous mode

As the following diagram shows, when the output current ( $I_{OUT}$ ) is relatively small,  $t_{open}$  will be smaller than  $t_{off}$  ( $t_{open} < t_{off}$ ). In this case, the all energy charged in the inductor during the time period of  $t_{on}$  will be discharged during the time period of  $t_{off}$ . As a result,  $I_L$  will be  $I_{Lmin}$  ( $=0$ ). If  $I_{OUT}$  is gradually increased, eventually  $t_{open}$  will be equal to  $t_{off}$  ( $t_{open}=t_{off}$ ). If  $I_{OUT}$  is further increased,  $I_{Lmin}$  will be larger than zero ( $I_{Lmin}>0$ ). The former mode ( $t_{open}<t_{off}$ ) is referred to as “discontinuous mode” and the latter mode ( $t_{open}=t_{off}$ ) is referred to as “continuous mode”.

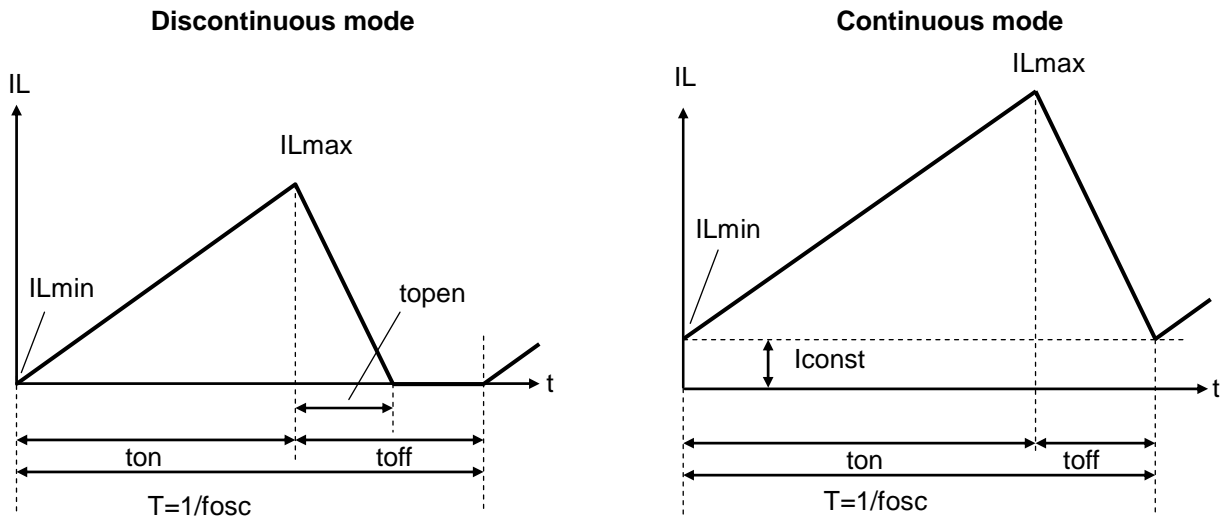

In the continuous mode, solve the equation 1 for  $t_{on}$ , and assume that the solution is  $t_{onc}$ .

$$t_{onc} = T \times V_{OUT} / V_{IN} \dots \dots \dots \text{Equation 2}$$

If  $t_{on}$  is smaller than  $t_{onc}$  ( $t_{on}<t_{onc}$ ), it is discontinuous mode. If  $t_{on}$  is equal to  $t_{onc}$  ( $t_{on}=t_{onc}$ ), it is continuous mode.

## Output Current and selection of External components

The relation between the output current and external components is as follows:

When Pch Tr. of L<sub>x</sub> is turned on:

(Ripple Current p-p value is described as I<sub>RP</sub>, On Resistances of Pch Tr. and Nch Tr. are respectively described as R<sub>ONP</sub> and R<sub>ONN</sub>. Also, the DC resistor of the inductor is described as R<sub>L</sub>.)

The time period of L<sub>x</sub> Pch Tr. being "ON" is described as t<sub>on</sub>.

$$V_{IN} = V_{OUT} + (R_{ONP} + R_L) \times I_{OUT} + L \times I_{RP} / t_{on} \dots\dots\dots \text{Equation 3}$$

The time period of L<sub>x</sub> Pch Tr. being "OFF" is described as t<sub>off</sub>. (Nch Tr. is "ON"):

$$L \times I_{RP} / t_{off} = R_{ONN} \times I_{OUT} + V_{OUT} + R_L \times I_{OUT} \dots\dots\dots \text{Equation 4}$$

Substitute Equation 4 into Equation 3 to solve for ON duty of Pch Tr.: (D<sub>ON</sub> = t<sub>on</sub> / (t<sub>off</sub> + t<sub>on</sub>)).

$$D_{ON} = (V_{OUT} + R_{ONN} \times I_{OUT} + R_L \times I_{OUT}) / (V_{IN} + R_{ONN} \times I_{OUT} - R_{ONP} \times I_{OUT}) \dots\dots\dots \text{Equation 5}$$

Ripple Current is solved by the following equation:

$$I_{RP} = (V_{IN} - V_{OUT} - R_{ONP} \times I_{OUT} - R_L \times I_{OUT}) \times D_{ON} / f_{osc} / L \dots\dots\dots \text{Equation 6}$$

Wherein, peak current that flows through L and L<sub>x</sub> Tr. is solved by the following equation:

$$I_{Lxmax} = I_{OUT} + I_{RP} / 2 \dots\dots\dots \text{Equation 7}$$

It is necessary to consider I<sub>Lxmax</sub> when deciding the input/output conditions and selecting the peripheral components.

\*The above calculation is based on the ideal operation of the ICs in continuous mode.

## TIMING CHART

### (1) Soft-Start Time

- In the case of starting the ICs with CE

The ICs start to operate when the CE pin voltage ( $V_{CE}$ ) exceeds the threshold voltage. The threshold voltage is set between CE "H" input voltage ( $V_{CEH}$ ) and CE "L" input voltage ( $V_{CEL}$ ).

When the ICs start to operate, the soft-start circuit also starts to operate. After a certain period of time, the reference voltage ( $V_{REF}$ ) of the inside the ICs gradually rise up to the specified value.

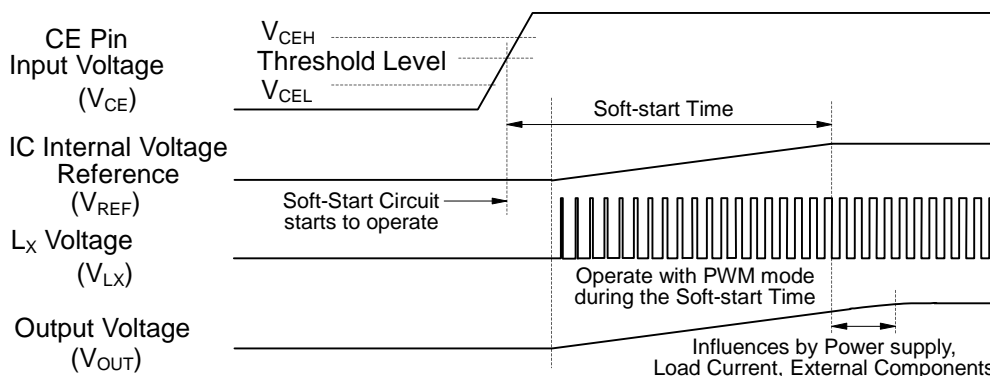

Soft-start time is the time period from when the soft-start circuit started to when the reference voltage reached to the specified value.

\* Soft-start time may not always equal to the actual start-up time of DC/DC converter.

Start-up speed could be affected by the power supply capacity, the output current value, the inductor value and capacitor value.

- In the case of starting with power supply

After starting up with power supply, the ICs starts to operate when the input voltage ( $V_{IN}$ ) exceeds the UVLO released voltage ( $V_{UVLO2}$ ). The soft-start circuit starts to operate and then the reference voltage ( $V_{REF}$ ) of the inside the ICs gradually rise up to the specified value.

Soft-start time is the time period from when the soft-start circuit started to when the reference voltage reached to the specified value.

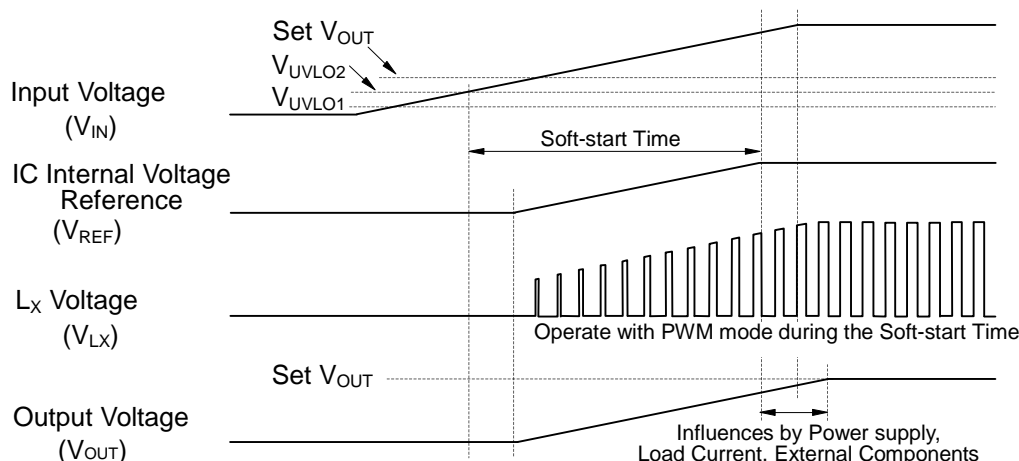

\*The start-up speed of the output voltage could be affected by the following elements.

(a) The start-up speed of the input voltage ( $V_{IN}$ ), which is determined by the power supply for the ICs and also by the input capacitor ( $C_{IN}$ ).

(b) The output capacitor ( $C_{OUT}$ ) value and the output current value.

**(2) Under Voltage Lockout (UVLO) Circuit**

The step-down DC/DC converter stops and ON duty becomes 100%, if input voltage ( $V_{IN}$ ) becomes less than the set output voltage (Set  $V_{OUT}$ ), the output voltage ( $V_{OUT}$ ) gradually drops according to the input voltage ( $V_{IN}$ ).

If the input voltage drops more and becomes less than UVLO detector threshold ( $V_{UVLO1}$ ), the under voltage lockout circuit (UVLO) operates, the IC internal reference voltage ( $V_{REF}$ ) stops, switching transistors turn off and the output voltage drops according to the load and output capacitor  $C_{OUT}$  value.

To restart the normal operation, the input voltage ( $V_{IN}$ ) must be more than the UVLO released voltage ( $V_{UVLO2}$ ). The timing chart below describes the operation with varying the input voltage ( $V_{IN}$ ).

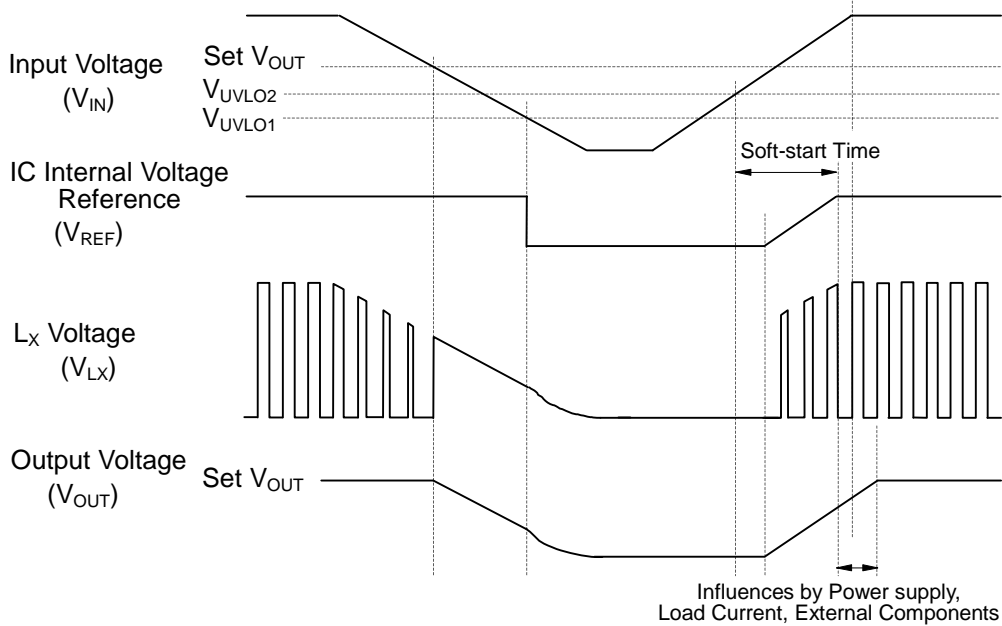

\* The start-up speeds of  $V_{OUT}$  at operation and recovery or the default voltage and the output current of  $C_{OUT}$ . Could affect on the waveform in the above chart. Therefore, the actual waveform could be slightly different from the waveform in the above chart.



**(3) Overcurrent Protection Circuit, Latch Type Protection Circuit**

Overcurrent protection circuit supervises the peak current of the inductor (The current passing through Pch Tr.) at each switching cycle. If the peak current exceeds the  $L_X$  current limit ( $I_{LXLIM}$ ), the overcurrent protection circuit turns off the Pch transistor. The  $L_X$  current limit of the RP502x Series is set at Typ. 900mA ( $V_{OUT} \geq 1.2V$ ), and Typ. 800mA ( $V_{OUT} < 1.2V$ ).

Latch type protection circuit latches the built-in driver in OFF state to stop the operation of the ICs if the overcurrent status continues more than the protection delay time ( $t_{prot}$ ).

\* $L_X$  limit current ( $I_{LXLIM}$ ) and the protection delay time ( $t_{prot}$ ) could be easily affected by self-heating and ambient environment. The drastic drop of input voltage ( $V_{IN}$ ) or the unstable input voltage caused by the short-circuiting in the output ( $V_{OUT}$ ) may affect on the protection operation and the delay time.

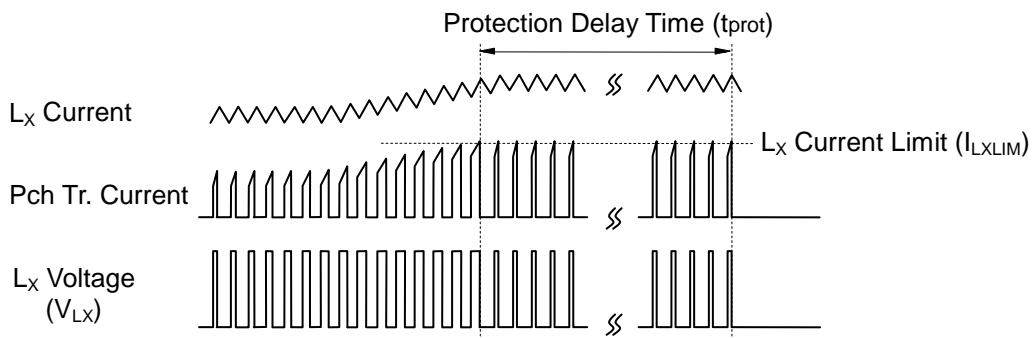

To release the latch type protection circuit, reset the ICs by inputting "L" into CE pin or make the input voltage lower than the UVLO detector threshold ( $V_{UVLO1}$ ).

As the following timing chart shows, the changing process of input voltage flows as follows: start-up, stable operation, high load condition, CE reset, stable operation, input voltage drop, input voltage recovery, and stable operation.

If the ICs enters the high load condition due to short-circuit or such, after the protection delay time ( $t_{prot}$ ), the built-in driver is latched in OFF state.  $V_{LX}$  becomes "L" and then the output voltage turns off. There are two ways of releasing the latch type protection:

- (1) CE reset makes the CE signal to "L" once and then turns the CE signal back to "H" again.
- (2) UVLO reset makes the input voltage lower than the UVLO voltage ( $V_{UVLO1}$ ).

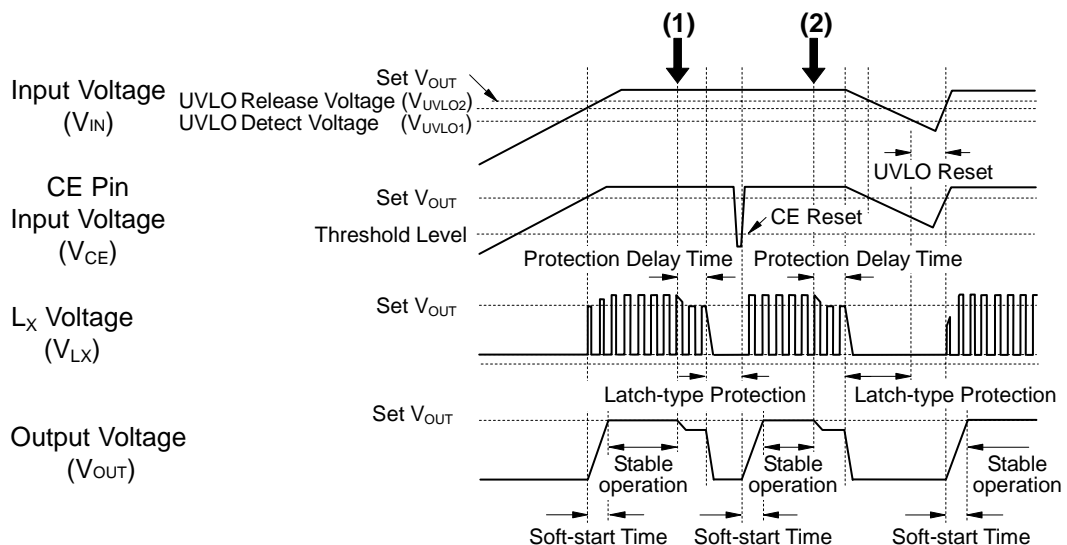

## TYPICAL CHARACTERISTICS

### 1) Output Voltage vs. Output Current

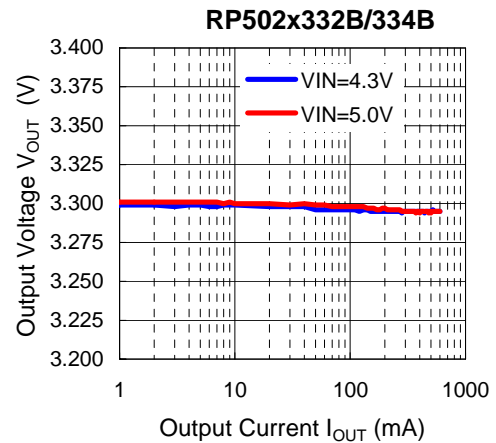
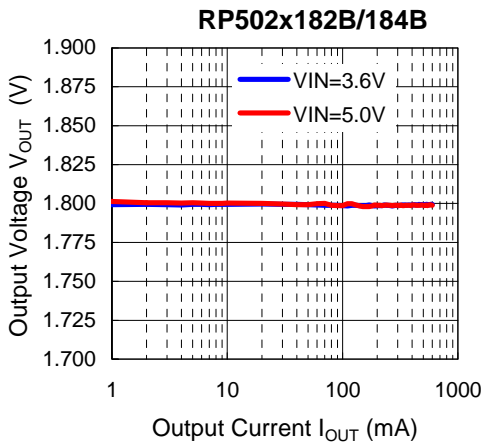
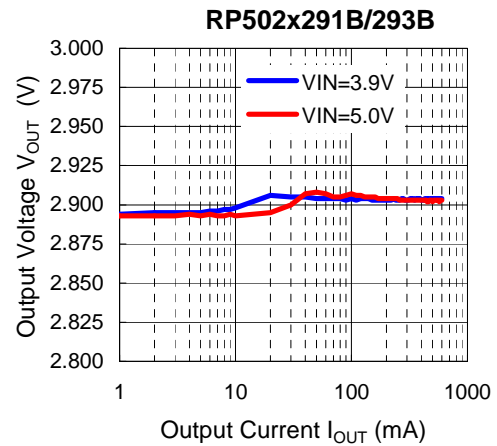
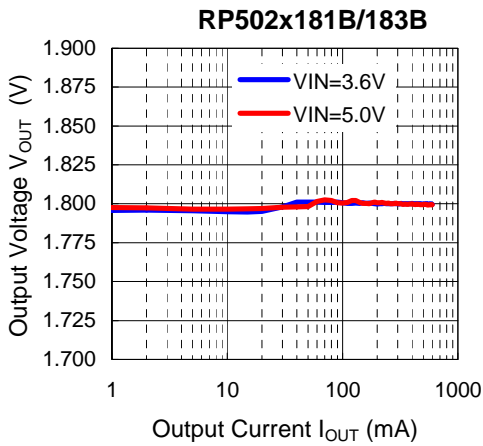
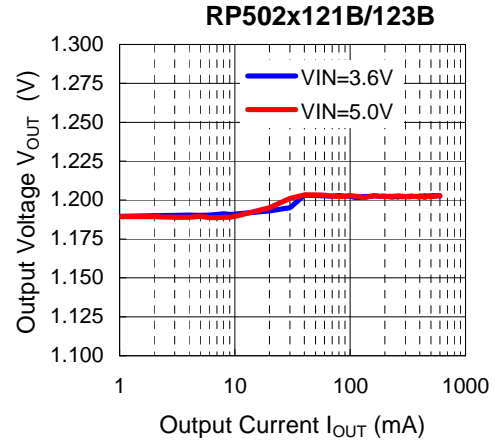
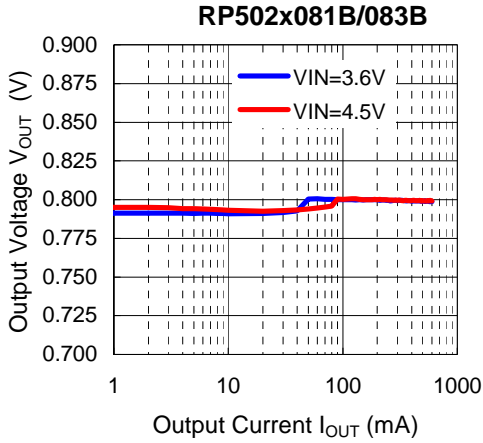

2) Output Voltage vs. Input Voltage

RP502x121B/123B

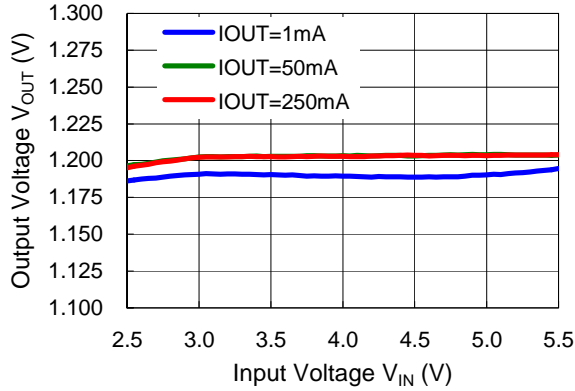

RP502x181B/183B

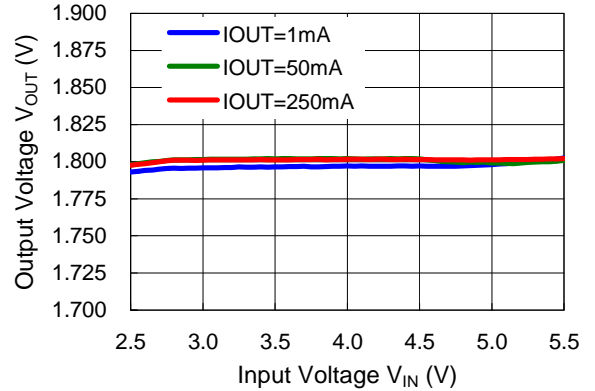

RP502x291B/293B

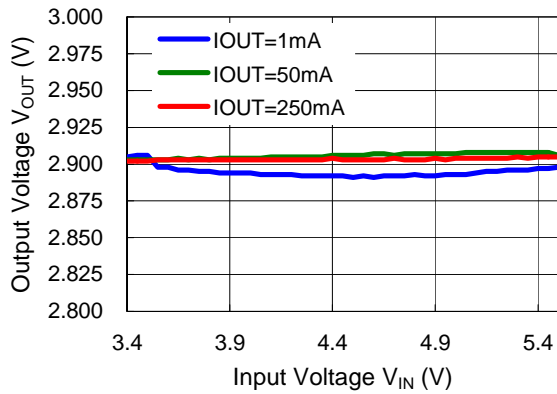

RP502x182B/184B

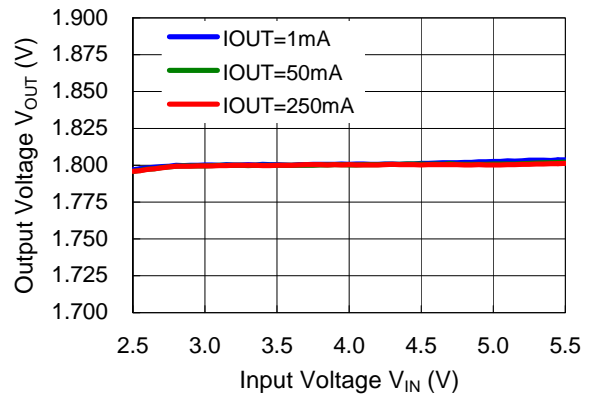

RP502x332B/334B

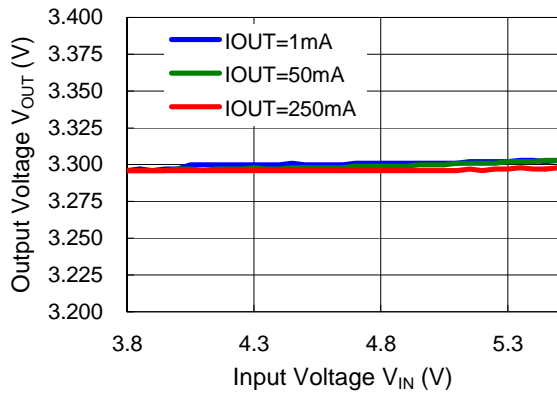

3) Output Voltage vs. Temperature

RP502x16xB

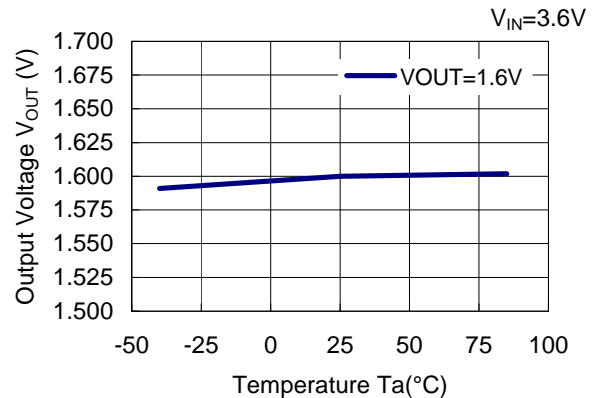

4) Efficiency vs. Output current

RP502x081B/083B

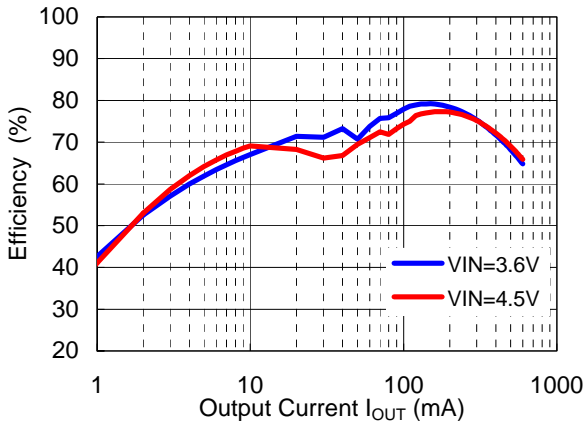

RP502x121B/123B

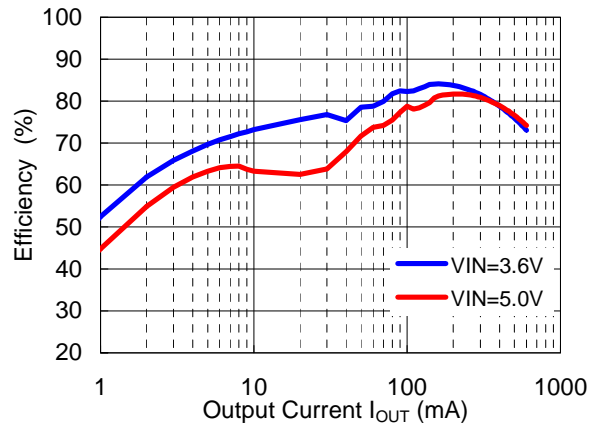

RP502x181B/183B

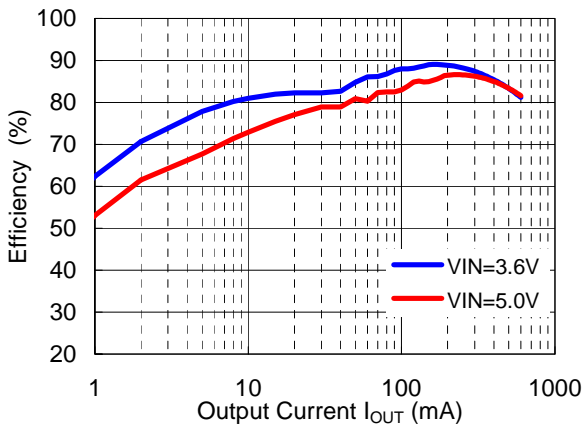

RP502x291B/293B

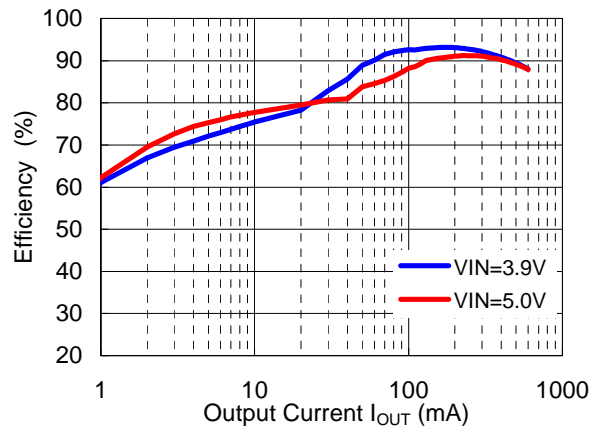

RP502x182B/184B

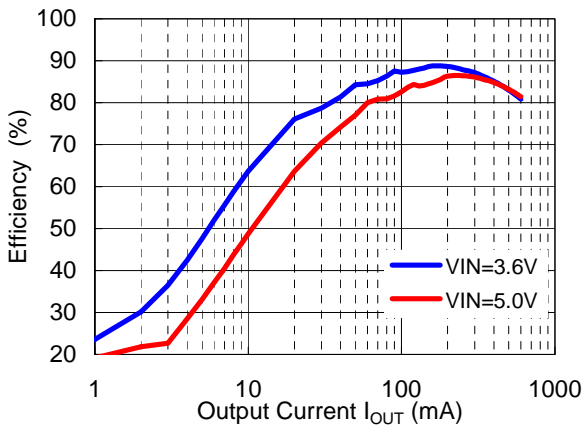

RP502x332B/334B

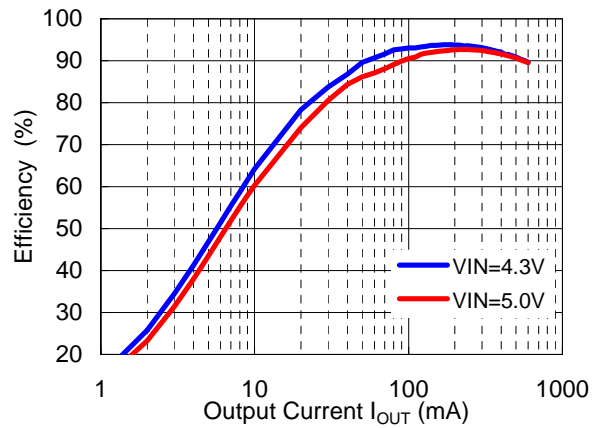

5) Supply Current 1, 2 vs. Temperature

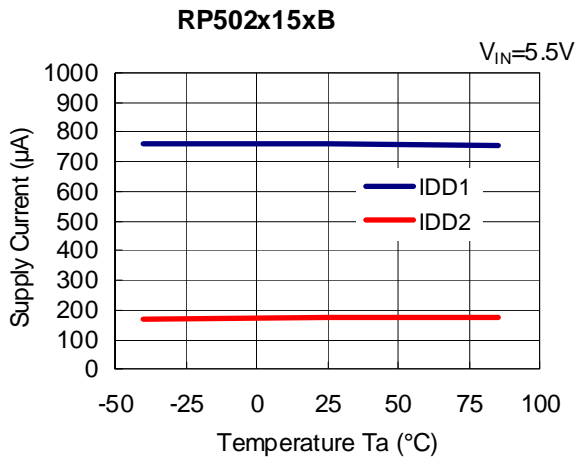

6) Supply Current 1, 2 vs. Input Voltage

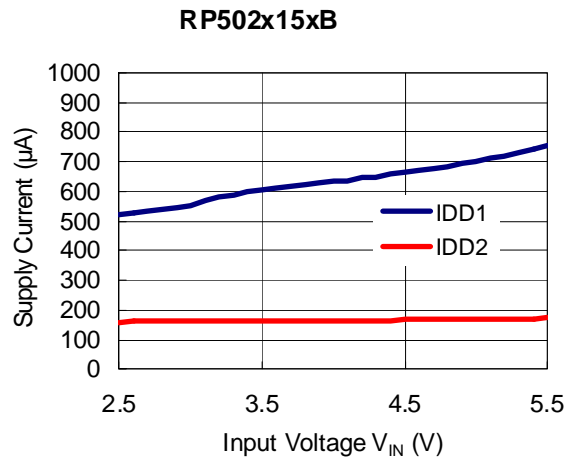

7) DC/DC Output Waveform

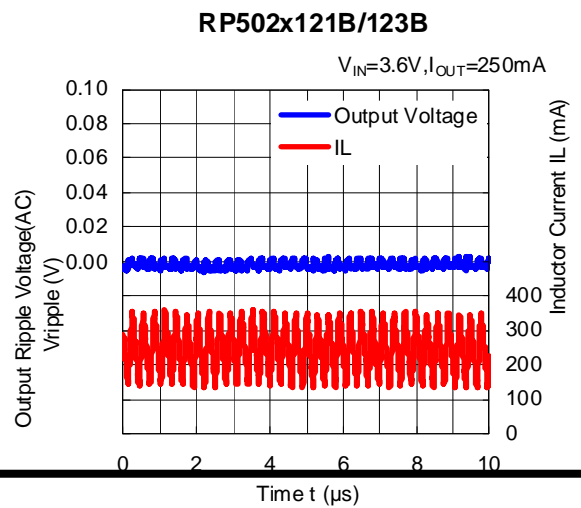
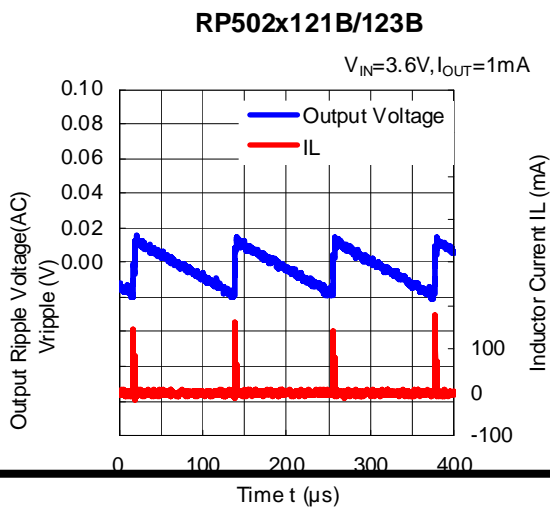
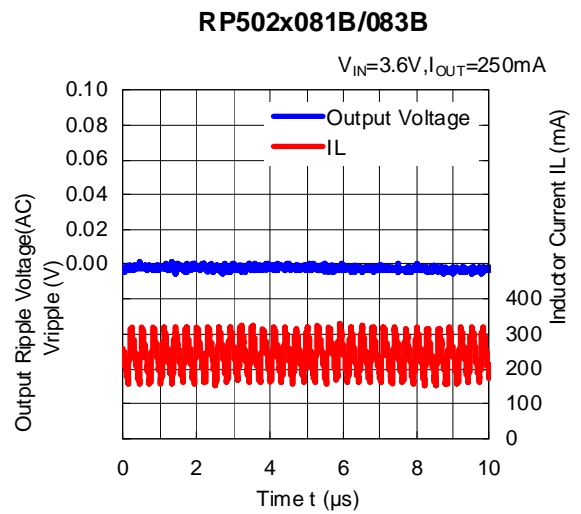
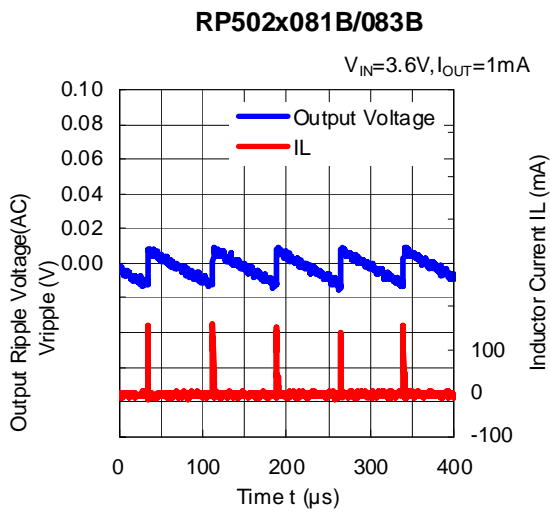

RP502x181B/183B

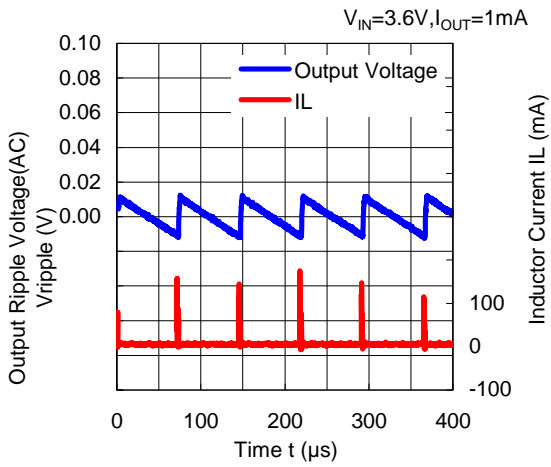

RP502x181B/183B

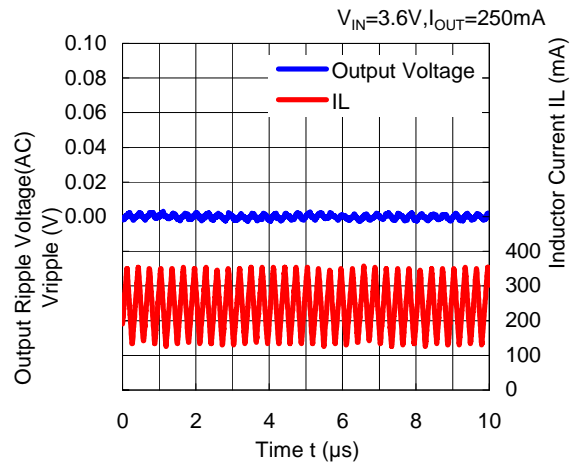

RP502x182B/184B

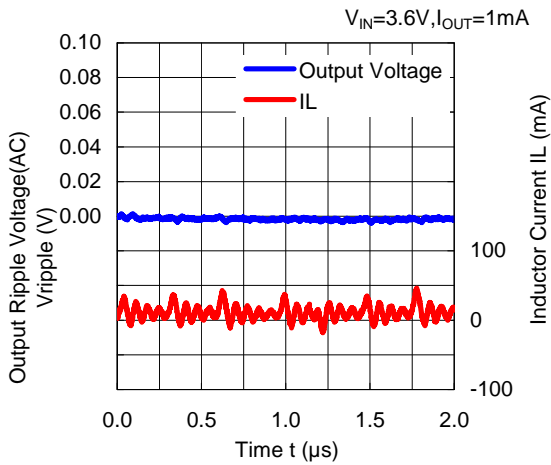

RP502x182B/184B

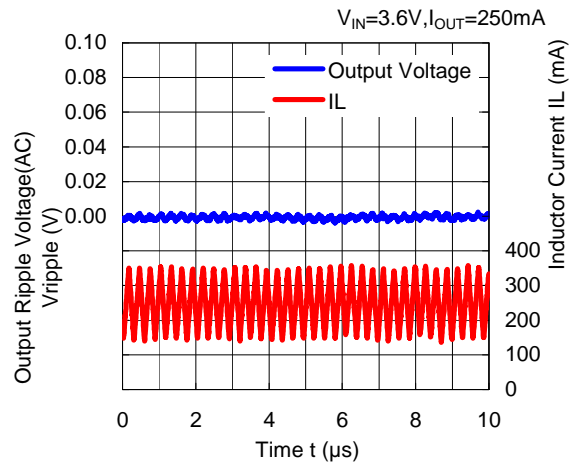

RP502x332B/334B

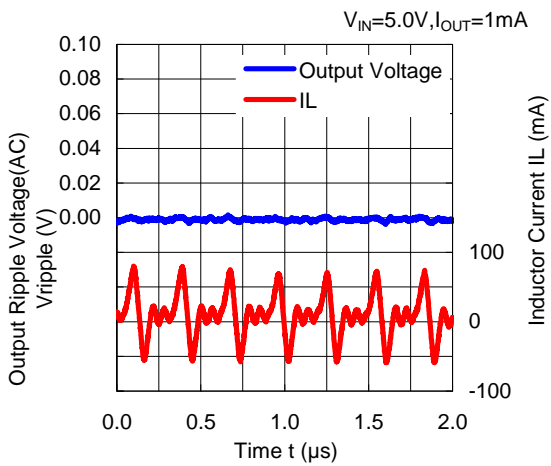

RP502x332B/334B

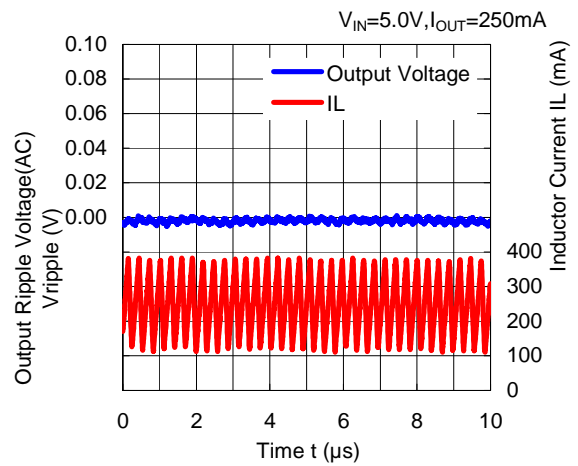

8) Oscillator Frequency vs. Temperature

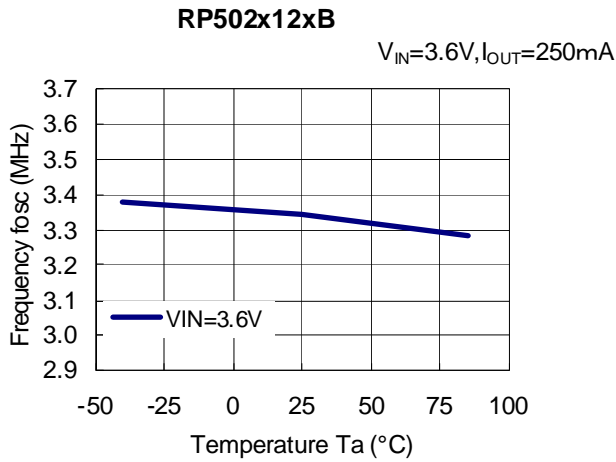

9) Oscillator Frequency vs. Input Voltage

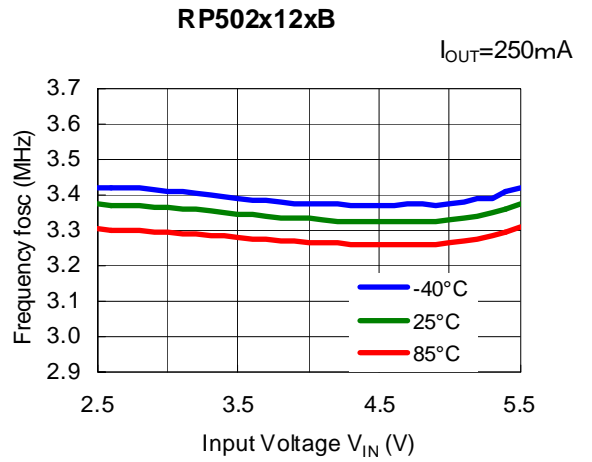

10) Soft-start Time vs. Temperature

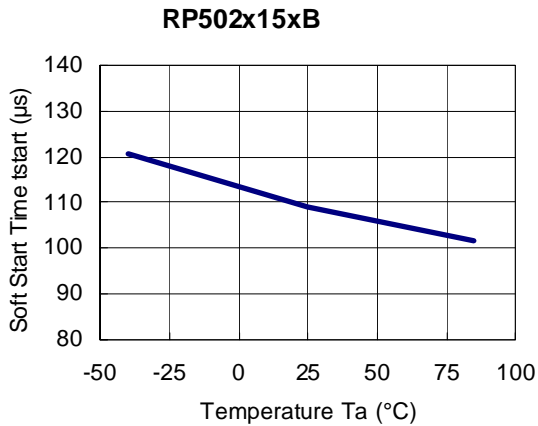

11) UVLO Detector Threshold / Released Voltage vs. Temperature

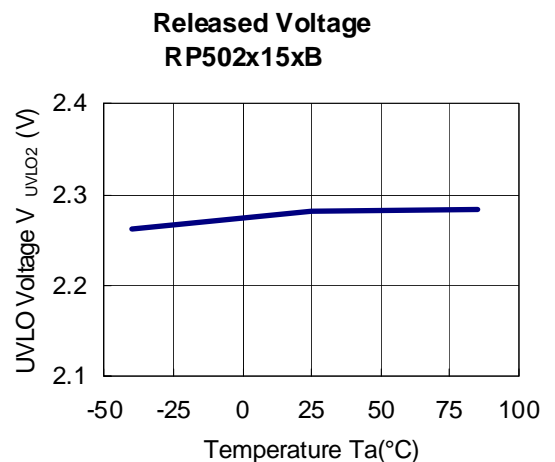
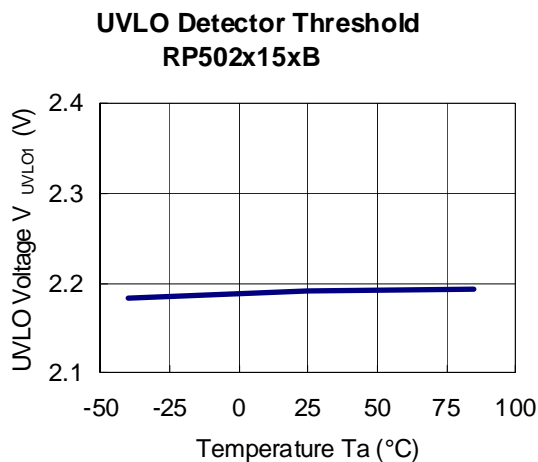

12) CE Input Voltage vs. Temperature

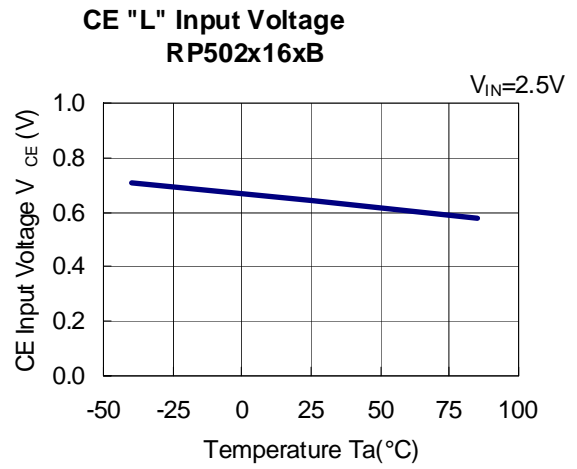
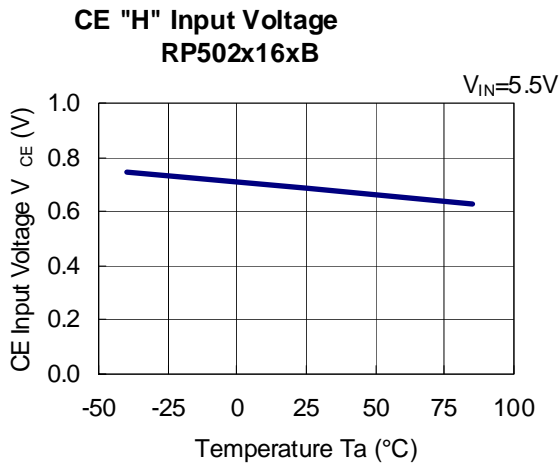

13) L<sub>x</sub> Current Limit vs. Temperature

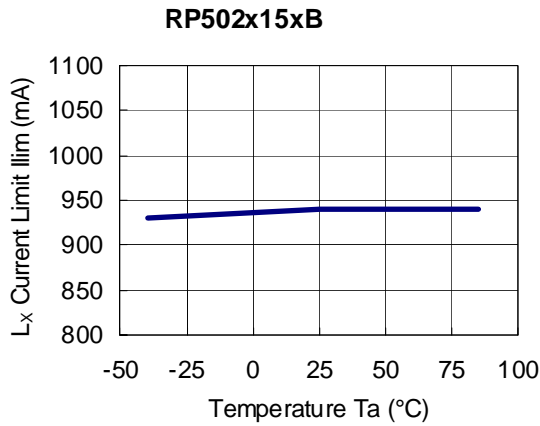

14) Nch Tr. ON Resistance vs. Temperature

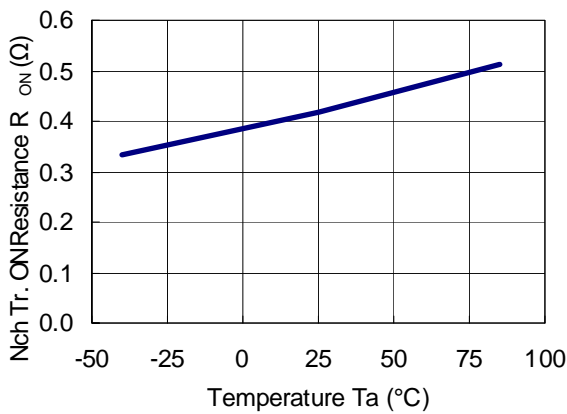

15) Pch Tr. ON Resistance vs. Temperature

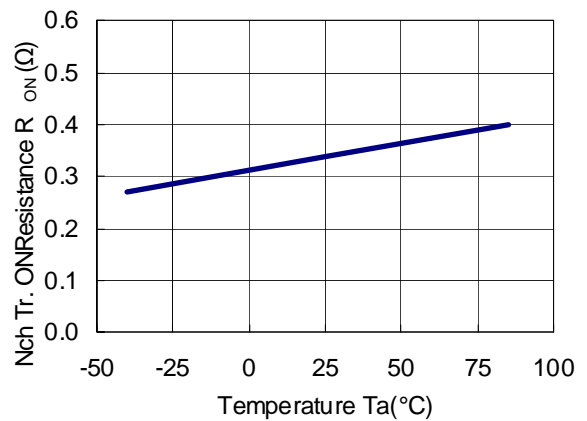



16) Turn on speed with CE pin

RP502x081B/083B

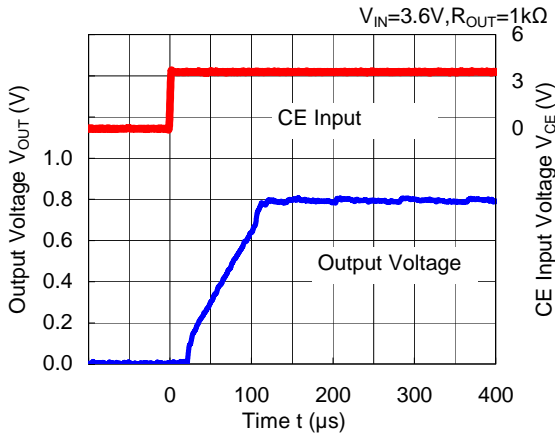

RP502x121B/123B

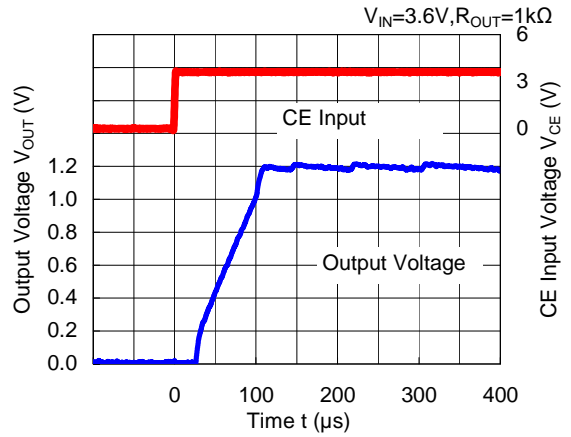

RP502x181B/183B

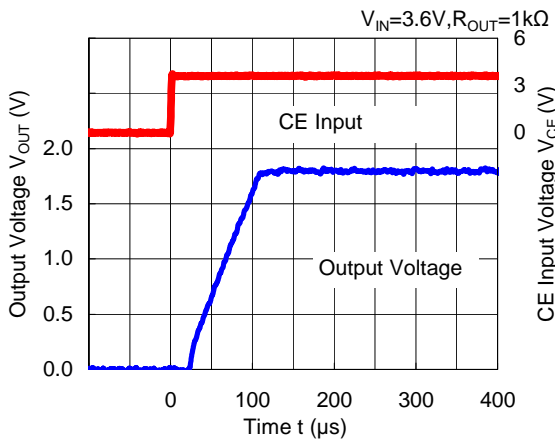

RP502x291B/293B

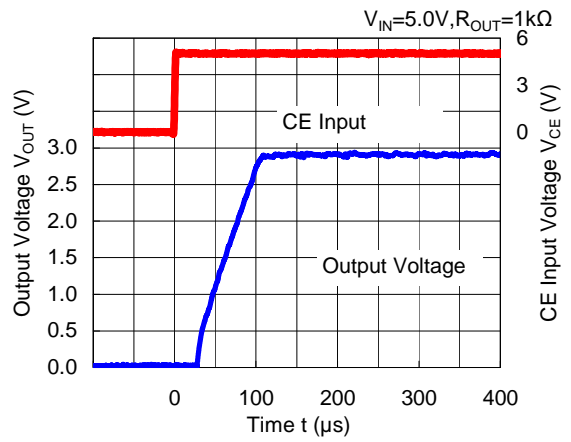

RP502x182B/184B

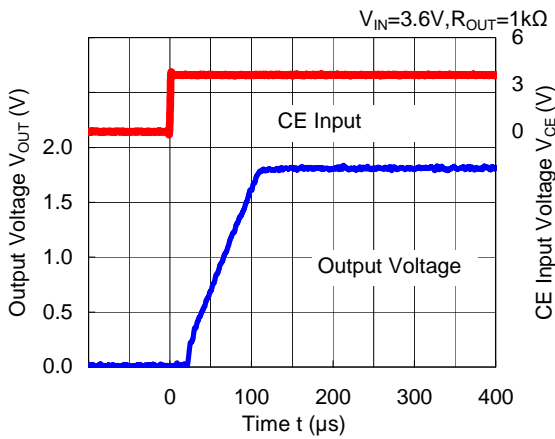

RP502x332B/334B

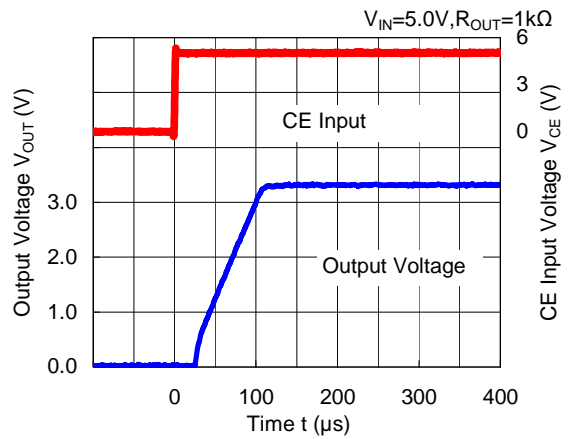

17) Load Transient Response

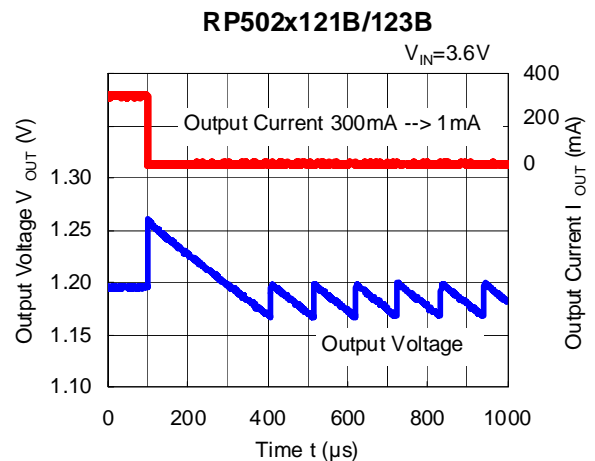
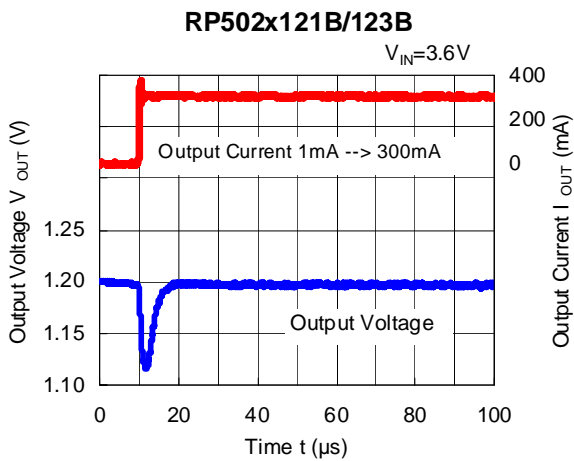
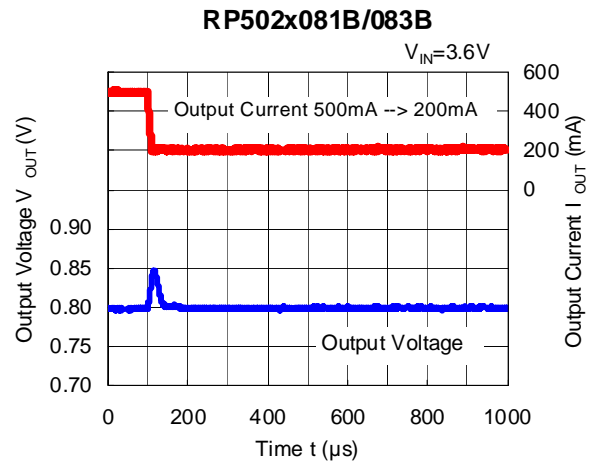
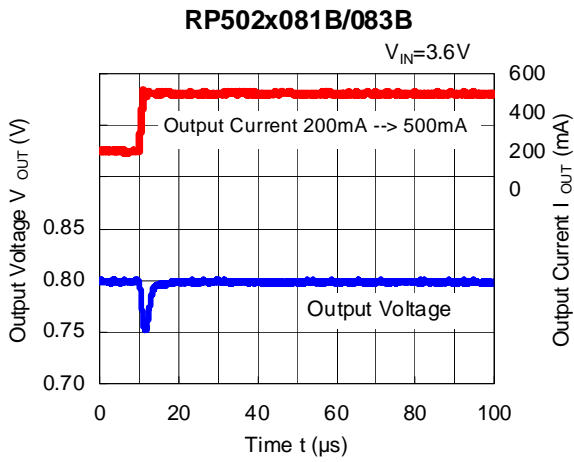
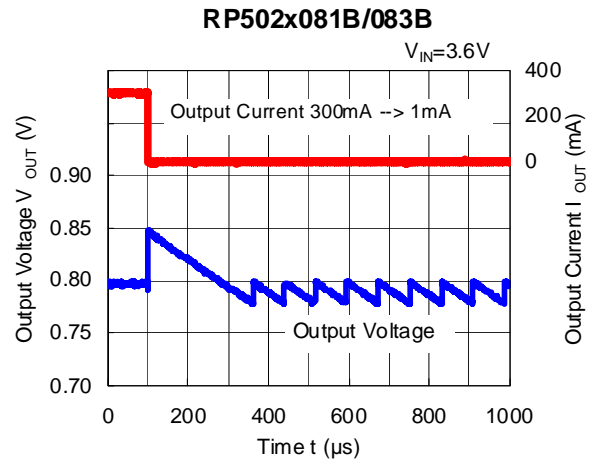
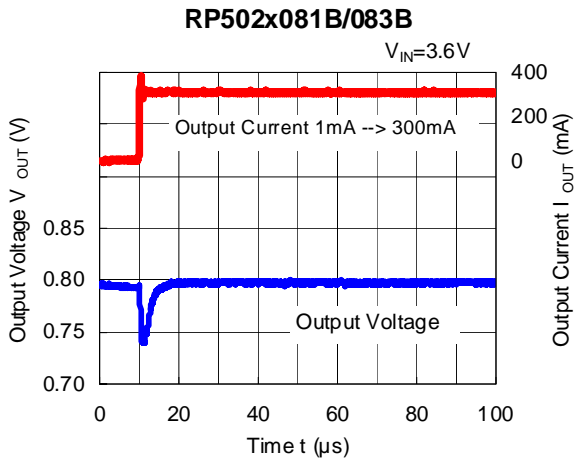

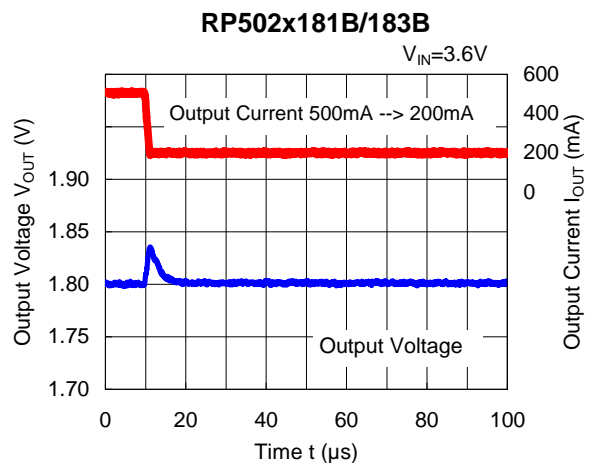
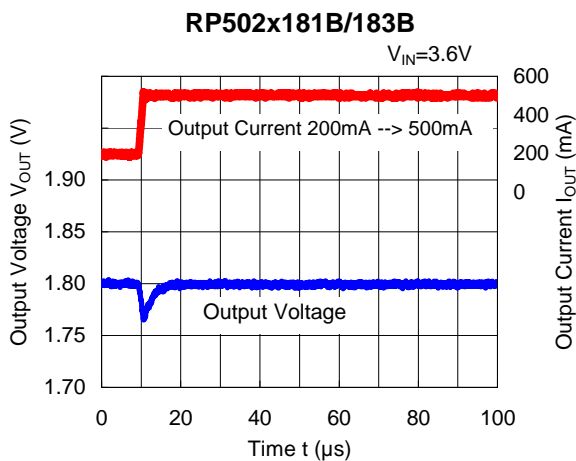
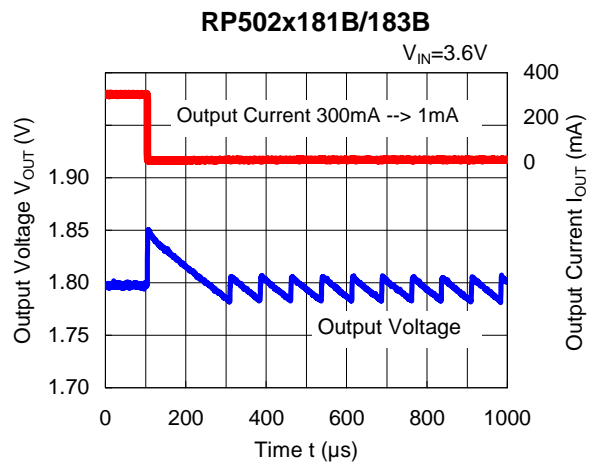
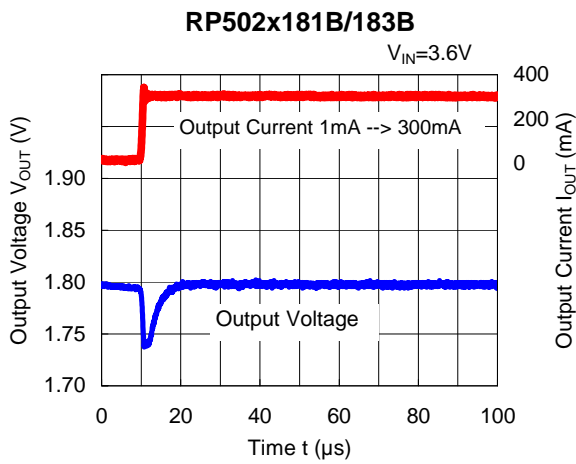
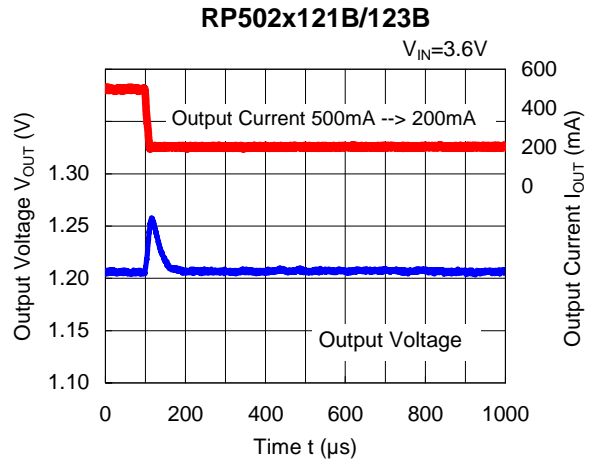
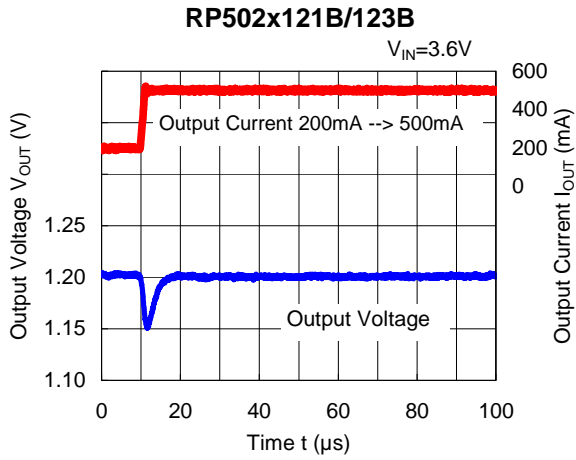

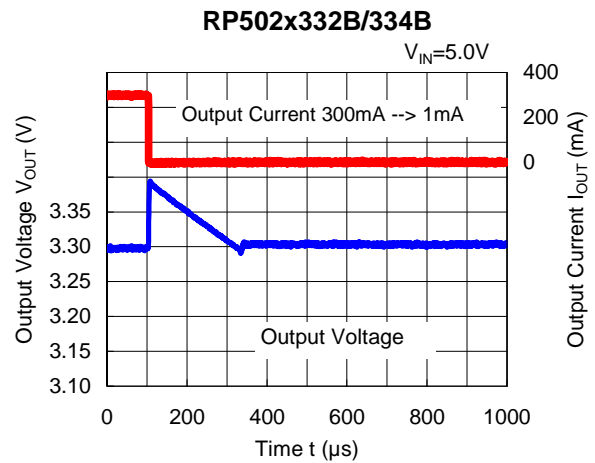
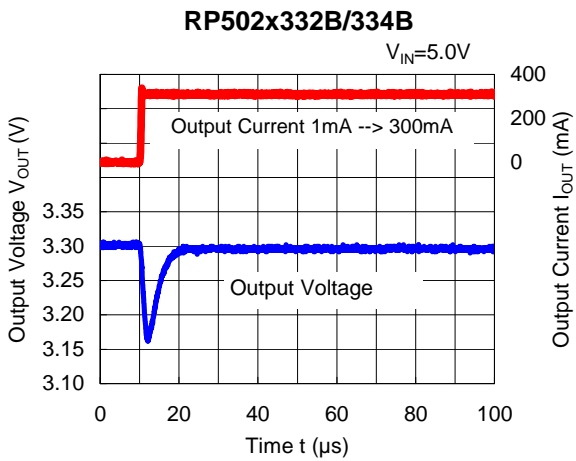
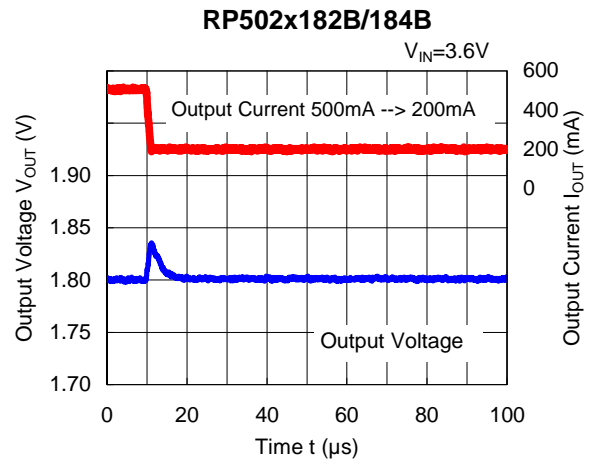
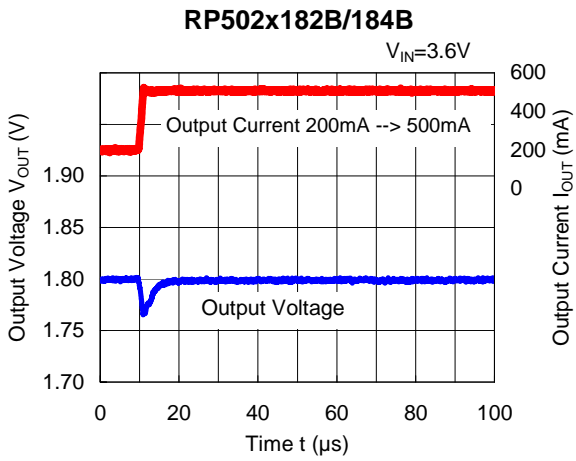
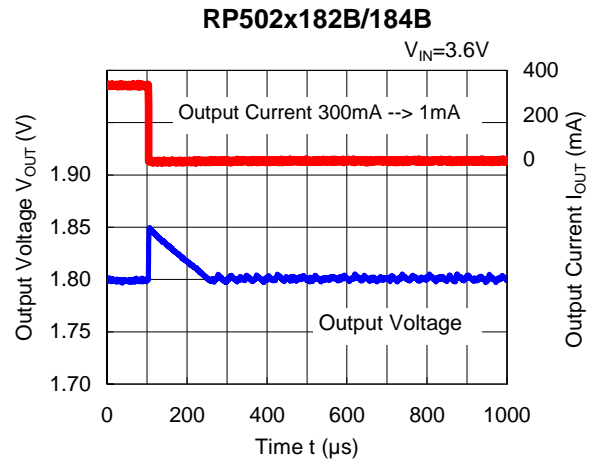
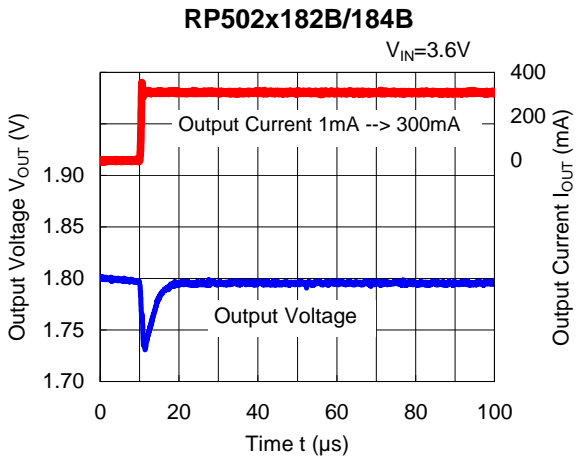

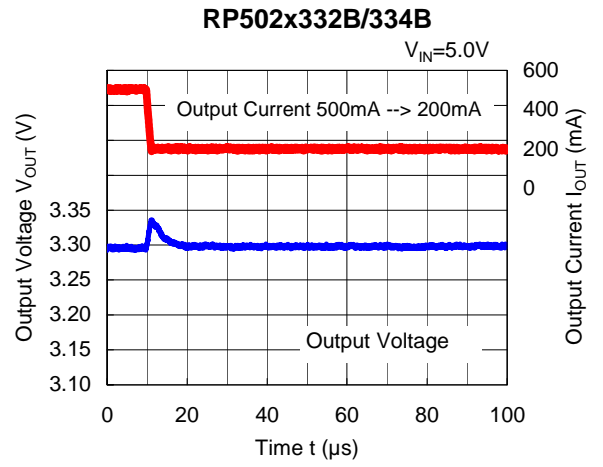
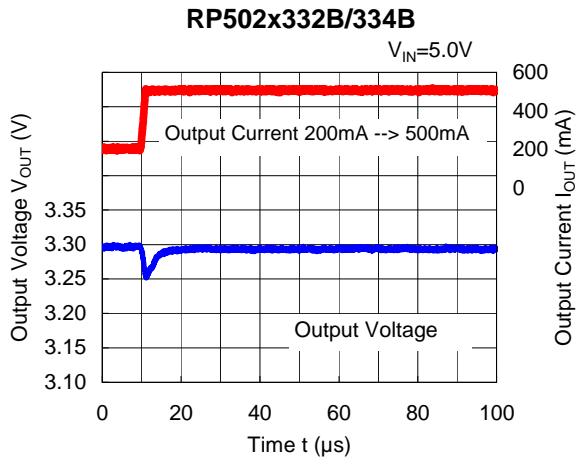



1. The products and the product specifications described in this document are subject to change or discontinuation of production without notice for reasons such as improvement. Therefore, before deciding to use the products, please refer to Ricoh sales representatives for the latest information thereon.
2. The materials in this document may not be copied or otherwise reproduced in whole or in part without prior written consent of Ricoh.
3. Please be sure to take any necessary formalities under relevant laws or regulations before exporting or otherwise taking out of your country the products or the technical information described herein.
4. The technical information described in this document shows typical characteristics of and example application circuits for the products. The release of such information is not to be construed as a warranty of or a grant of license under Ricoh's or any third party's intellectual property rights or any other rights.
5. The products listed in this document are intended and designed for use as general electronic components in standard applications (office equipment, telecommunication equipment, measuring instruments, consumer electronic products, amusement equipment etc.). Those customers intending to use a product in an application requiring extreme quality and reliability, for example, in a highly specific application where the failure or misoperation of the product could result in human injury or death (aircraft, spacevehicle, nuclear reactor control system, traffic control system, automotive and transportation equipment, combustion equipment, safety devices, life support system etc.) should first contact us.
6. We are making our continuous effort to improve the quality and reliability of our products, but semiconductor products are likely to fail with certain probability. In order to prevent any injury to persons or damages to property resulting from such failure, customers should be careful enough to incorporate safety measures in their design, such as redundancy feature, fire containment feature and fail-safe feature. We do not assume any liability or responsibility for any loss or damage arising from misuse or inappropriate use of the products.
7. Anti-radiation design is not implemented in the products described in this document.
8. The X-ray exposure can influence functions and characteristics of the products. Confirm the product functions and characteristics in the evaluation stage.
9. WLCSP products should be used in light shielded environments. The light exposure can influence functions and characteristics of the products under operation or storage.
10. There can be variation in the marking when different AOI (Automated Optical Inspection) equipment is used. In the case of recognizing the marking characteristic with AOI, please contact Ricoh sales or our distributor before attempting to use AOI.
11. Please contact Ricoh sales representatives should you have any questions or comments concerning the products or the technical information.



**Ricoh is committed to reducing the environmental loading materials in electrical devices with a view to contributing to the protection of human health and the environment.**

Ricoh has been providing RoHS compliant products since April 1, 2006 and Halogen-free products since April 1, 2012.

**RICOH** RICOH ELECTRONIC DEVICES CO., LTD.

<https://www.e-devices.ricoh.co.jp/en/>

#### Sales & Support Offices

##### **Ricoh Electronic Devices Co., Ltd.**

##### **Shin-Yokohama Office (International Sales)**

2-3, Shin-Yokohama 3-chome, Kohoku-ku, Yokohama-shi, Kanagawa, 222-8530, Japan  
Phone: +81-50-3814-7687 Fax: +81-45-474-0074

##### **Ricoh Americas Holdings, Inc.**

675 Campbell Technology Parkway, Suite 200 Campbell, CA 95008, U.S.A.  
Phone: +1-408-610-3105

##### **Ricoh Europe (Netherlands) B.V.**

##### **Semiconductor Support Centre**

Prof. W.H. Keesomlaan 1, 1183 DJ Amstelveen, The Netherlands  
Phone: +31-20-5474-309

##### **Ricoh International B.V. - German Branch**

##### **Semiconductor Sales and Support Centre**

Oberrather Strasse 6, 40472 Düsseldorf, Germany  
Phone: +49-211-6546-0

##### **Ricoh Electronic Devices Korea Co., Ltd.**

3F, Haesung Bldg, 504, Teheran-ro, Gangnam-gu, Seoul, 135-725, Korea  
Phone: +82-2-2135-5700 Fax: +82-2-2051-5713

##### **Ricoh Electronic Devices Shanghai Co., Ltd.**

Room 403, No.2 Building, No.690 Bibo Road, Pu Dong New District, Shanghai 201203,  
People's Republic of China  
Phone: +86-21-5027-3200 Fax: +86-21-5027-3299

##### **Ricoh Electronic Devices Shanghai Co., Ltd.**

##### **Shenzhen Branch**

1205, Block D (Jinlong Building), Kingkey 100, Hongbao Road, Luohu District,  
Shenzhen, China  
Phone: +86-755-8348-7600 Ext 225

##### **Ricoh Electronic Devices Co., Ltd.**

##### **Taipei office**

Room 109, 10F-1, No.51, Hengyang Rd., Taipei City, Taiwan (R.O.C.)  
Phone: +886-2-2313-1621/1622 Fax: +886-2-2313-1623

# Mouser Electronics

Authorized Distributor

Click to View Pricing, Inventory, Delivery & Lifecycle Information:

## Ricoh Electronics:

[RP502L101B-TR](#) [RP502L121B-TR](#) [RP502L123B-TR](#) [RP502L124B-TR](#) [RP502L153B-TR](#) [RP502L164B-TR](#)  
[RP502L334B-TR](#) [RP502Z123B-E2-F](#) [RP502Z153B-E2-F](#) [RP502Z253B-E2-F](#) [RP502Z333B-E2-F](#) [RP502L291B-TR](#)  
[RP502L293B-TR](#) [RP502L301B-TR](#) [RP502L331B-TR](#) [RP502L332B-TR](#) [RP502L333B-TR](#) [RP502L181B-TR](#)  
[RP502L183B-TR](#) [RP502L184B-TR](#) [RP502L193B-TR](#) [RP502L194B-TR](#) [RP502L214B-TR](#)



Компания «ЭлектроПласт» предлагает заключение долгосрочных отношений при поставках импортных электронных компонентов на взаимовыгодных условиях!

Наши преимущества:

- Оперативные поставки широкого спектра электронных компонентов отечественного и импортного производства напрямую от производителей и с крупнейших мировых складов;
- Поставка более 17-ти миллионов наименований электронных компонентов;
- Поставка сложных, дефицитных, либо снятых с производства позиций;
- Оперативные сроки поставки под заказ (от 5 рабочих дней);
- Экспресс доставка в любую точку России;
- Техническая поддержка проекта, помощь в подборе аналогов, поставка прототипов;
- Система менеджмента качества сертифицирована по Международному стандарту ISO 9001;
- Лицензия ФСБ на осуществление работ с использованием сведений, составляющих государственную тайну;
- Поставка специализированных компонентов (Xilinx, Altera, Analog Devices, Intersil, Interpoint, Microsemi, Aeroflex, Peregrine, Syfer, Eurofarad, Texas Instrument, Miteq, Cobham, E2V, MA-COM, Hittite, Mini-Circuits, General Dynamics и др.);

Помимо этого, одним из направлений компании «ЭлектроПласт» является направление «Источники питания». Мы предлагаем Вам помощь Конструкторского отдела:

- Подбор оптимального решения, техническое обоснование при выборе компонента;
- Подбор аналогов;
- Консультации по применению компонента;
- Поставка образцов и прототипов;
- Техническая поддержка проекта;
- Защита от снятия компонента с производства.



#### Как с нами связаться

**Телефон:** 8 (812) 309 58 32 (многоканальный)

**Факс:** 8 (812) 320-02-42

**Электронная почта:** [org@eplast1.ru](mailto:org@eplast1.ru)

**Адрес:** 198099, г. Санкт-Петербург, ул. Калинина, дом 2, корпус 4, литера А.