

NOTES: (G)

1. DRAWING TO BE INTERPRETED IN ACCORDANCE WITH THE CURRENT REVISION OF ASME Y14.5.
 2. THIS PART/PRODUCT IS TO BE MANUFACTURED WITH THE LATEST APPLICABLE REGULATIONS OF EC DIRECTIVES FOR THE RESTRICTION OF THE USE OF HAZARDOUS SUBSTANCES IN ELECTRICAL AND ELECTRONIC EQUIPMENT (ROHS), WASTE ELECTRICAL AND ELECTRONIC EQUIPMENT (WEEE) AND REGISTRATION, EVALUATION, AUTHORIZATION AND RESTRICTION OF CHEMICALS (REACH)
- ▲ LABEL TO INCLUDE:
PART NUMBER
"OTTO 21649"
DATE CODE (YYYY)
- ▲ OUTPUTS ARE FROM THE CENTER TO THE FULL TRAVEL POSITION IN EACH DIRECTION.
OPTIONS "AA", "BB", "CC", "DD", "EE", "FF" PROVIDE INCREASED VOLTAGE IN +X, +Y; AND DECREASING VOLTAGE IN -X, -Y DIRECTION FROM ONE OUTPUT PER AXIS.
OPTIONS "GG" AND "HH" PROVIDE INCREASING VOLTAGES IN ALL DIRECTIONS (+X, +Y, -X, -Y) FROM 2 OUTPUTS PER AXIS.
▲ OPTIONS "BB" AND "EE" PROVIDE REDUNDANT OUTPUT 2 WHICH DUPLICATES OUTPUT 1
OPTIONS "CC" AND "FF" PROVIDE REDUNDANT OUTPUT 2 WHICH IS INVERSE OF OUTPUT 1
▲ FULL BOOT VERSION SHOWN AS DEFAULT. SEE PAGE 4 FOR ALTERNATIVE SWITCH/BOOT STYLES.
- ▲ GATED IS RESTRICTED MOVEMENT IN Y AXIS ONLY.
▲ USE N FOR FULL BOOT, Z-AXIS, & NO PUSHBUTTON OPTIONS.
▲ 1-9 USED ONLY FOR PUSHBUTTON OPTIONS.
NOT APPLICABLE IN Z-AXIS.

(G) JHT-

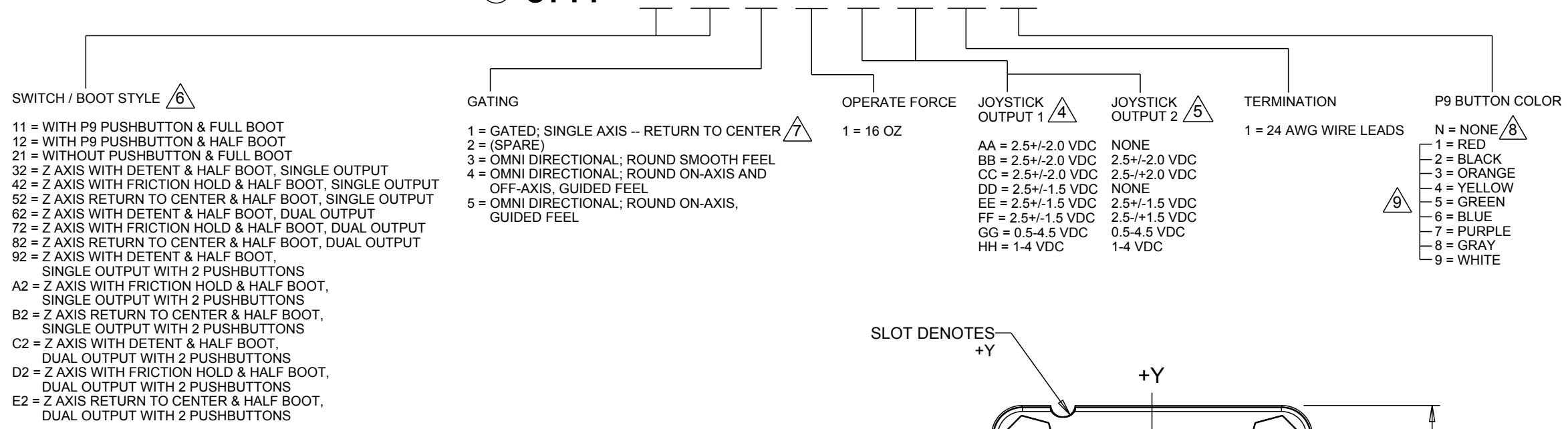

REV	OCN #	DATE	APR
A	059022	20 DEC 10	DCF
B	061838	20 JUN 11	MRM
C	064410	06 JAN 12	MRM
D	064707	31 JAN 12	DCF
E	065360	30 MAR 12	DCF
F	070007	08 APR 13	KLW
G	070711	30 MAY 13	KLW

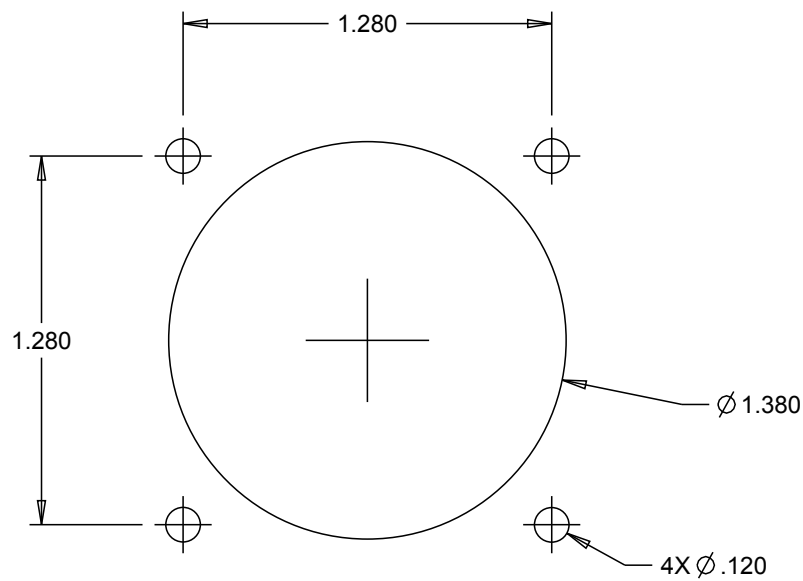

SUGGESTED PANEL OPENING
MAX. PANEL THICKNESS OF 0.140

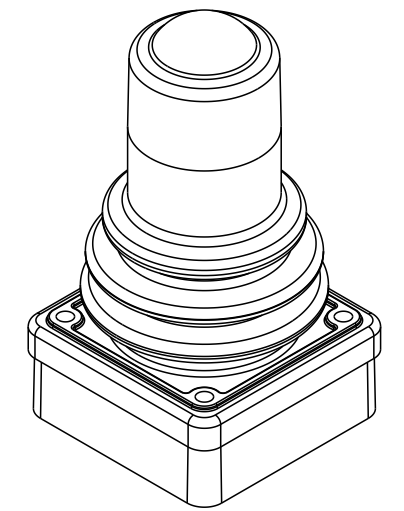
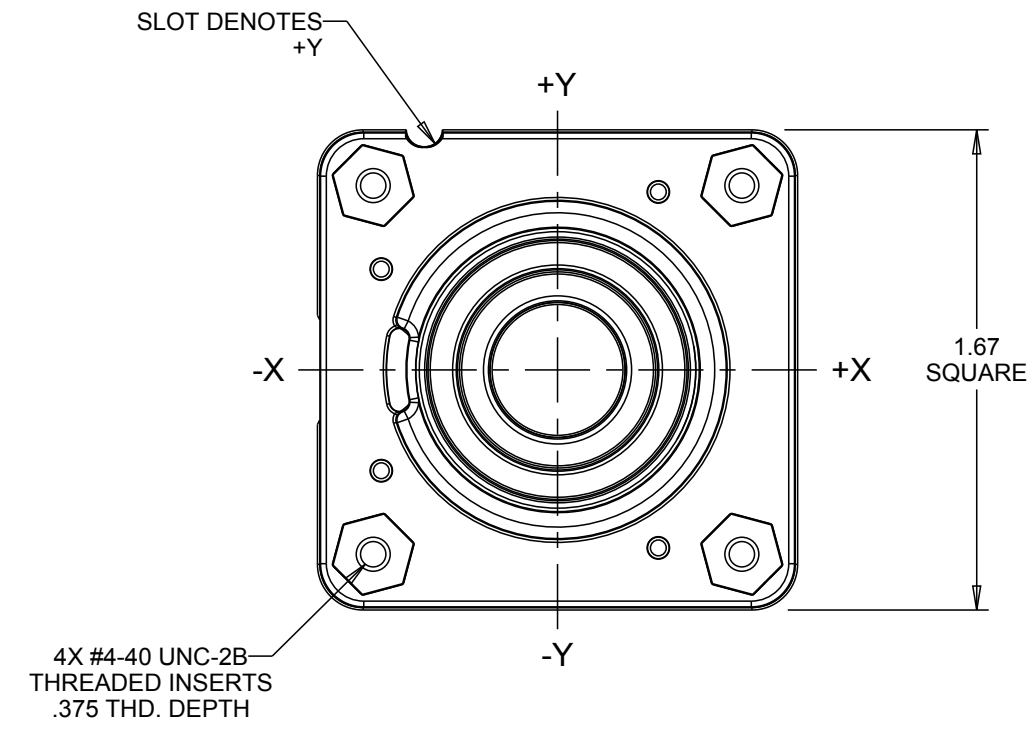

SCALE 4:5

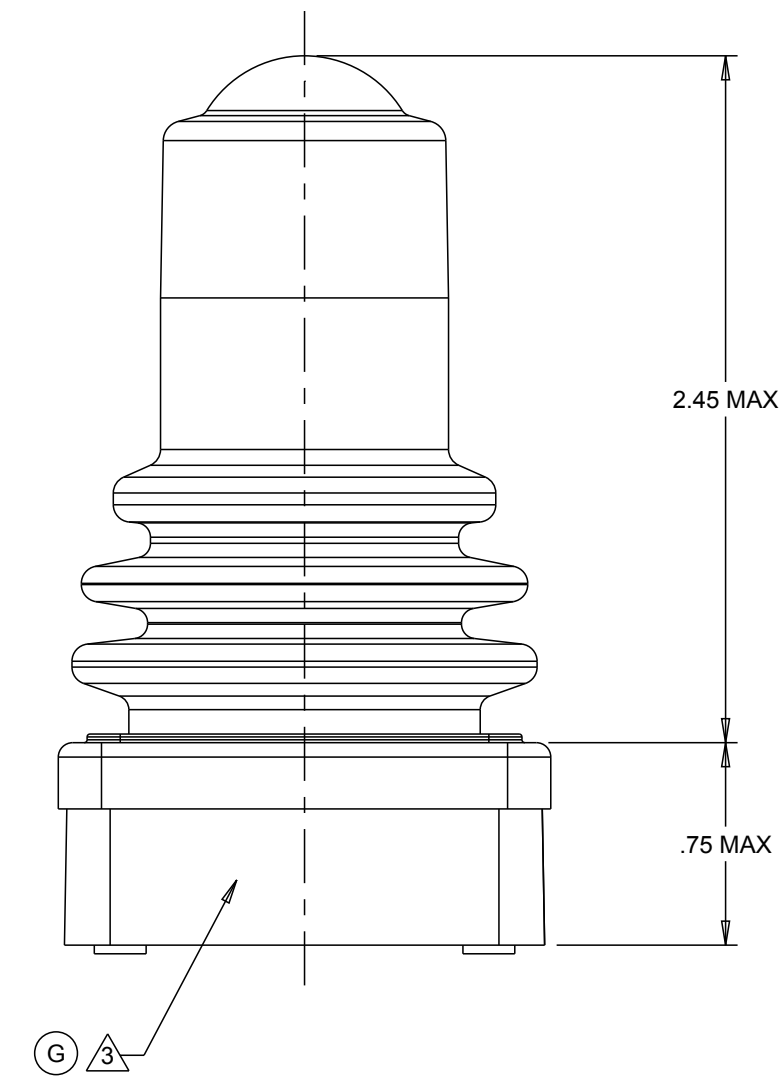
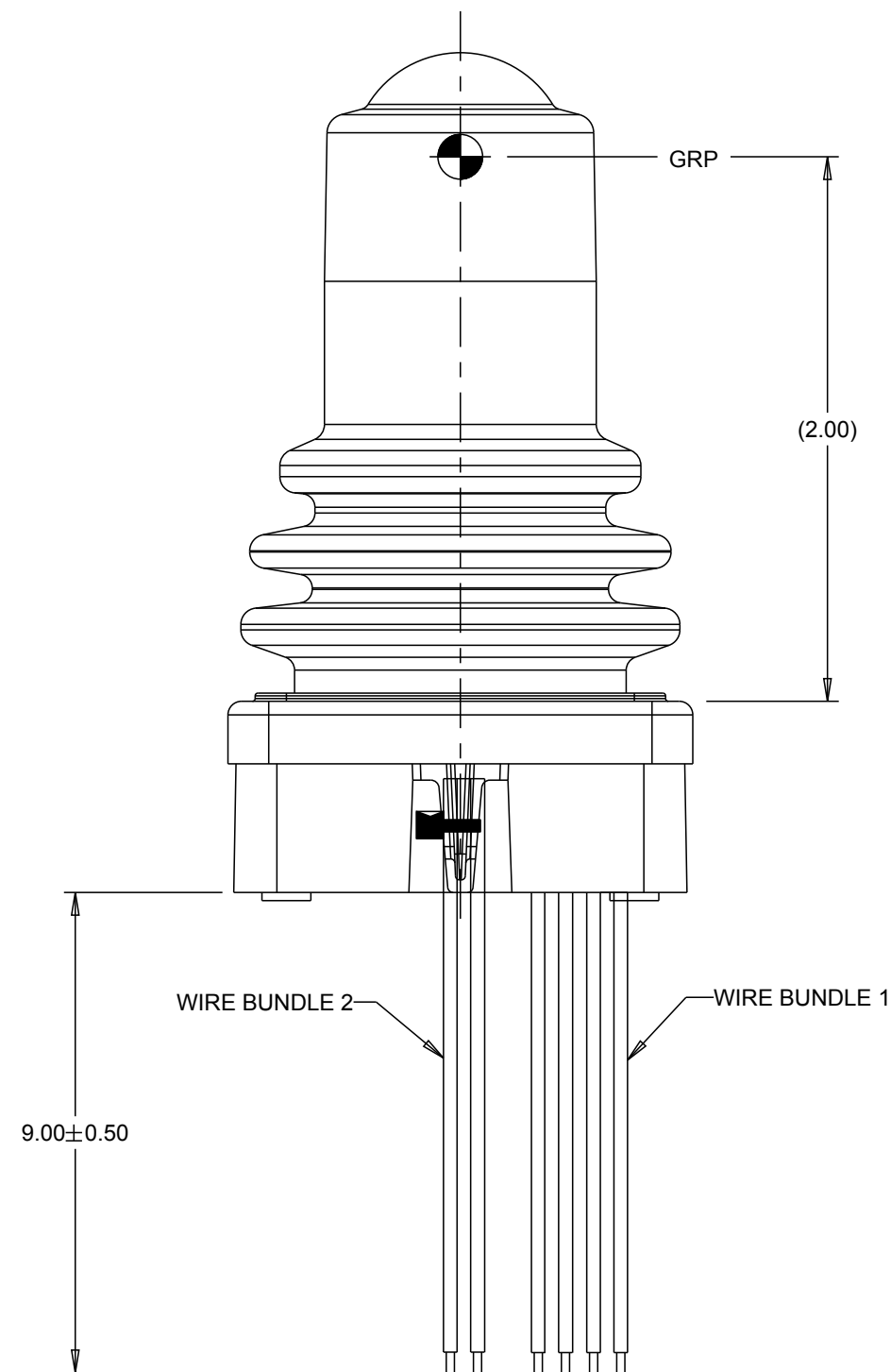

WIRES NOT SHOWN IN ALL VIEWS FOR CLARITY

- MANUFACTURING
- SPC
- SPECIAL REQUIREMENT

UNLESS OTHERWISE SPECIFIED:
DIMENSIONS ARE IN INCHES.
TOLERANCES:
.XX ±.03
.XXX ±.010
ANGLES ±2°
DO NOT SCALE



THIS DOCUMENT IS THE CONFIDENTIAL PROPERTY OF OTTO ENGINEERING, INC.. IT IS NOT TO BE USED IN ANY WAY DETRIMENTAL TO THE INTERESTS OF OTTO ENGINEERING, INC..

DESCRIPTION		JHT, LINEAR HALL EFFECT JOYSTICK	
DRWN. JLW	SIZE C	FSCM NO. 21649	DRAWING NO. JHT-
CHKD. MRM	APPD. AH	REV. G	Scale 3:2
THIRD ANGLE PROJECTION		Sheet 1 OF 4	

PRODUCT SPECIFICATIONS				
ELECTRICAL:				
JOYSTICK				
RATED AT V _{cc} = 5V @ 20° C LOAD = 1ma (4.7KΩ)	UNITS	MIN	TYP	MAX
SUPPLY VOLTAGE	VDC	4.50	5.00	5.50
OUTPUT VOLTAGE TOLERANCE AT CENTER (SEE APPROPRIATE GRAPH FOR OUTPUT VOLTAGES)	VDC @5V V _{cc}	-25	N/A	+25
OUTPUT VOLTAGE TOLERANCE FULL TRAVEL (SEE APPROPRIATE GRAPH FOR OUTPUT VOLTAGES)	VDC @5V V _{cc}	-25	N/A	+25
SUPPLY CURRENT PER OUTPUT B=0, V _{cc} =5V, I _o =0	mA	N/A	10	12
OUTPUT IMPEDANCE	kΩ	N/A	1.0	N/A
P9				
SPST-NO-DB				
JOYSTICK Z AXIS RETURN TO CENTER				
RATED AT V _{cc} = 5V @ 20° C LOAD = 1ma (4.7KΩ)	UNITS	MIN	TYP	MAX
SUPPLY VOLTAGE	VDC	4.50	5.00	5.50
OUTPUT 1+2 VOLTAGE, +Z, -Z 0° DEFLECTION	VDC @5V V _{cc}	2.25	2.50	2.75
OUTPUT 1+2 AT FULL TRAVEL +Z DIRECTION	VDC @5V V _{cc}	4.25	4.50	4.55
OUTPUT 1+2 AT FULL TRAVEL -Z DIRECTION	VDC @5V V _{cc}	0.45	0.50	0.75
SUPPLY CURRENT (PER SENSOR) B=0, V _{cc} =5V, I _o =0	mA	NA	NA	10
OUTPUT SOURCE CURRENT LIMIT B=-X*, V _o =0	mA	-1.0	NA	1.0
JOYSTICK Z AXIS FRICTION				
RATED AT V _{cc} = 5V @ 20° C LOAD = 1ma (4.7KΩ)	UNITS	MIN	TYP	MAX
SUPPLY VOLTAGE	VDC	4.50	5.00	5.50
OUTPUT 1+2 AT FULL TRAVEL +Z DIRECTION	VDC @5V V _{cc}	4.25	4.50	4.55
OUTPUT 1+2 AT FULL TRAVEL -Z DIRECTION	VDC @5V V _{cc}	0.45	0.50	0.75
SUPPLY CURRENT (PER SENSOR) B=0, V _{cc} =5V, I _o =0	mA	NA	NA	10
OUTPUT SOURCE CURRENT LIMIT B=-X*, V _o =0	mA	-1.0	NA	1.0
JOYSTICK Z AXIS 3 DETENT				
RATED AT V _{cc} = 5V @ 20° C LOAD = 1ma (4.7KΩ)	UNITS	MIN	TYP	MAX
SUPPLY VOLTAGE	VDC	4.50	5.00	5.50
OUTPUT 1+2 VOLTAGE, +Z, -Z 0° DEFLECTION	VDC @5V V _{cc}	2.25	2.50	2.75
OUTPUT 1+2 AT FULL TRAVEL +Z DIRECTION	VDC @5V V _{cc}	4.25	4.50	4.55
OUTPUT 1+2 AT FULL TRAVEL -Z DIRECTION	VDC @5V V _{cc}	0.45	0.50	0.75
SUPPLY CURRENT (PER SENSOR) B=0, V _{cc} =5V, I _o =0	mA	NA	NA	10
OUTPUT SOURCE CURRENT LIMIT B=-X*, V _o =0	mA	-1.0	NA	1.0
MECHANICAL:				
JOYSTICK				
MECHANICAL LIFE ALL DIRECTIONS		5,000,000 CYCLES		
TRAVEL ANGLE	DEGREES	18	20	22
OVER TRAVEL ANGLE	DEGREES	0.5	1.0	1.5
MAX ALLOWABLE RADIAL FORCE (STYLES 11, 12, & 21) @ GRP	LBS	N/A	N/A	50
MAX ALLOWABLE RADIAL FORCE (ALL OTHER STYLES) @ GRP	LBS	N/A	N/A	15
P9				
MECHANICAL LIFE		1,000,000 CYCLES		
OPERATING FORCE @ 20° C	OZ	8	12	16
KEYPAD				
MECHANICAL LIFE		1,000,000 CYCLES		
OPERATIONAL FORCE	OZ	2	4	6
Z AXIS				
MECHANICAL LIFE ALL DIRECTIONS		1,000,000 CYCLES		
TRAVEL ANGLE (TOTAL)	DEGREES	56	60	64
OPERATIONAL TORQUE WITH DETENT	IN-OZ	10	20	30
OPERATIONAL TORQUE WITH FRICTION HOLD	IN-OZ	1	4	7
OPERATIONAL TORQUE RETURN TO CENTER	IN-OZ	8	16	24
MAXIMUM ALLOWABLE ROTATIONAL TORQUE	IN-LBS	N/A	N/A	15
ENVIRONMENTAL:				
OPERATING TEMPERATURE	°C	-40	20	85
KEYPAD				
ELECTRONICS SEAL INTEGRITY	WATERTIGHT TO IP65			
JOYSTICK				
ELECTRONICS SEAL INTEGRITY	WATERTIGHT TO IP68S, 1 METER			
EMI/RFI WITHSTAND	PER SAE J1113 CONTACT FACTORY FOR DETAILS			
MATERIAL:				
HOUSING	THERMOPLASTIC, BLACK			
BELLOWS	SILICONE, BLACK			
HARDWARE	NOT PROVIDED			

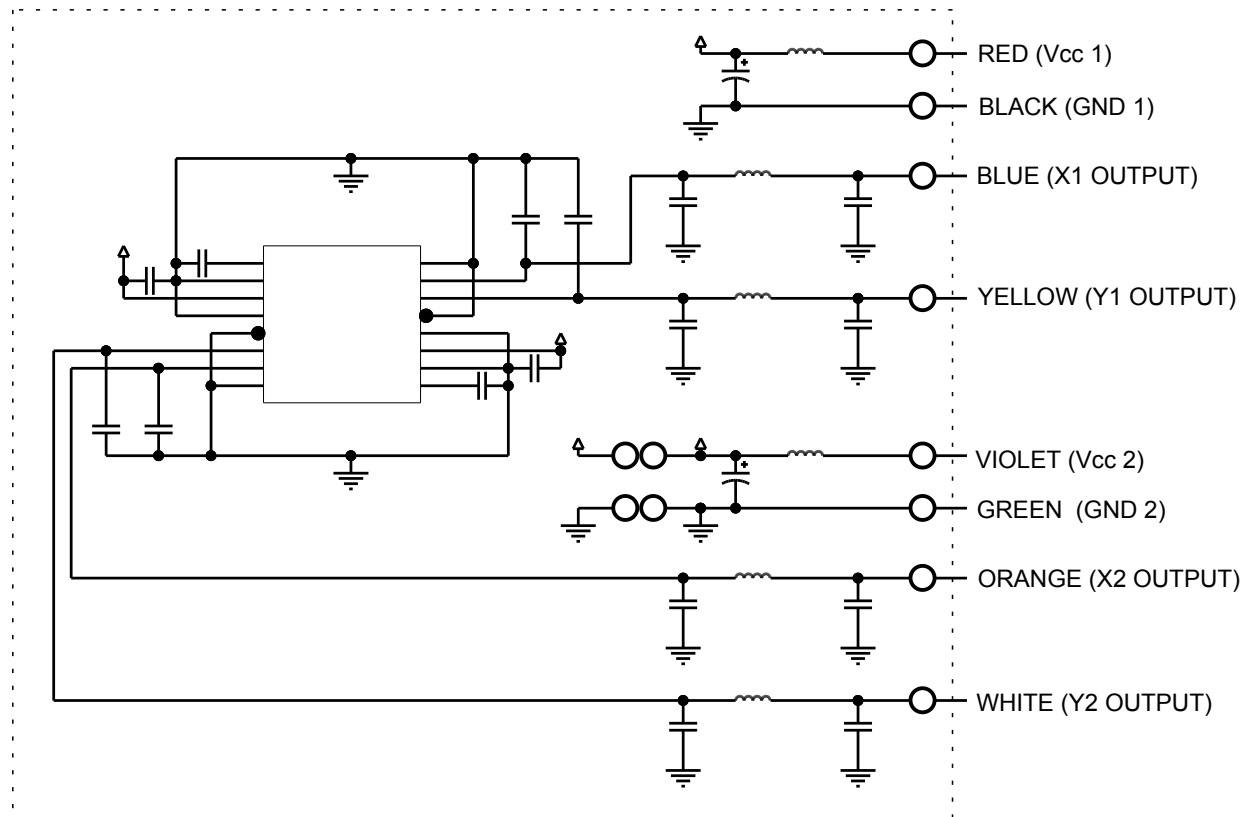

GENERAL SCHEMATIC
(WIRE BUNDLE 1)

ALL OUTPUTS ARE NOT PRESENT IN ALL CONFIGURATIONS

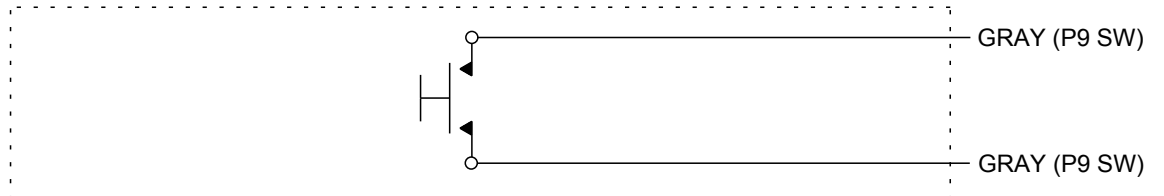

PUSHBUTTON SCHEMATIC
(WIRE BUNDLE 2)

ALL WIRES ARE NOT PRESENT IN ALL CONFIGURATIONS

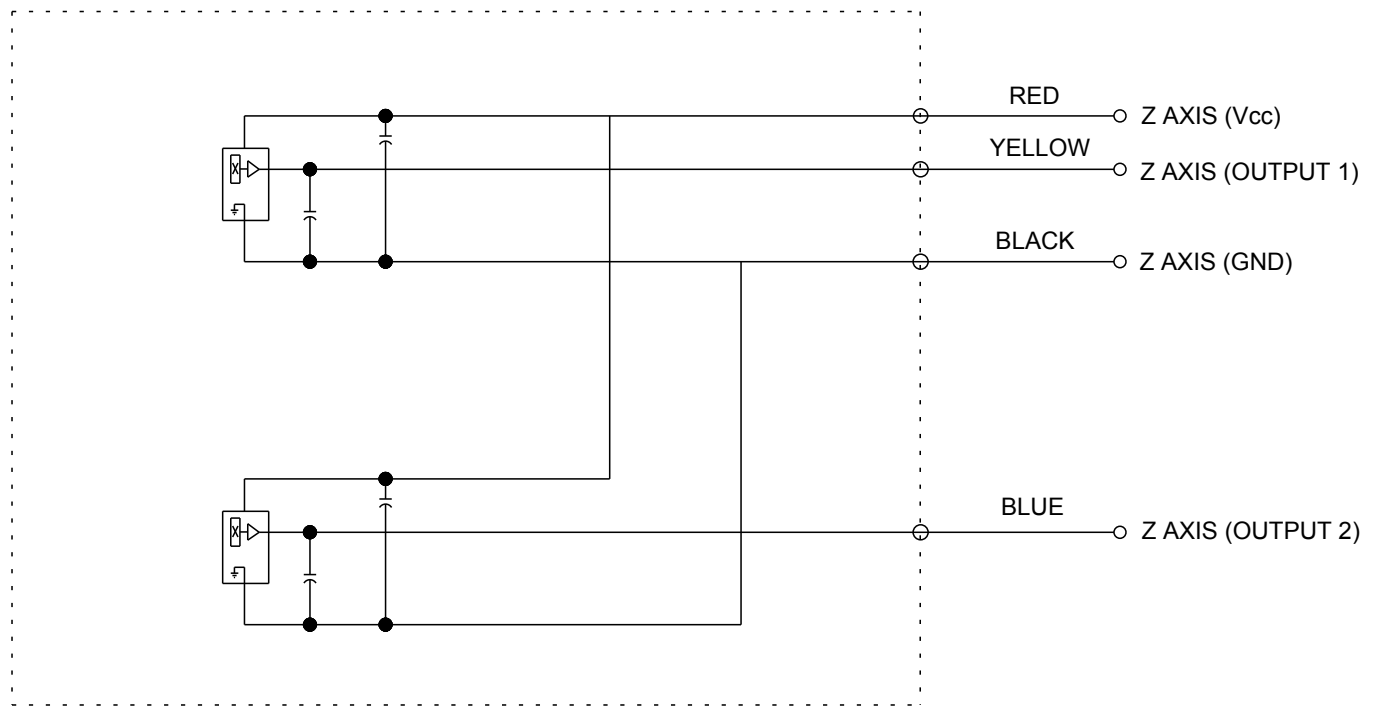

Z AXIS SCHEMATIC
(WIRE BUNDLE 2)

ALL WIRES ARE NOT PRESENT IN ALL CONFIGURATIONS

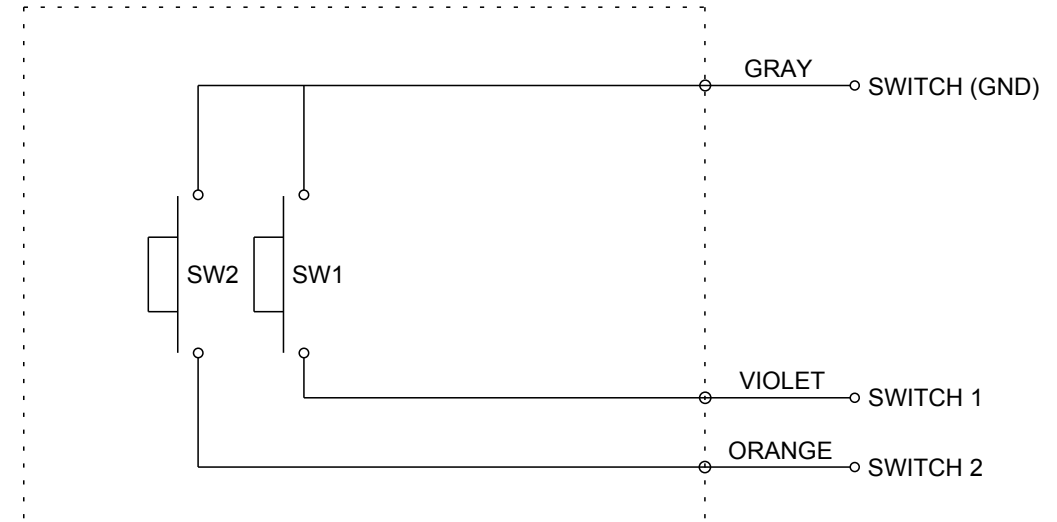

KEYPAD SCHEMATIC
(WIRE BUNDLE 2)

ALL WIRES ARE NOT PRESENT IN ALL CONFIGURATIONS

UNLESS OTHERWISE SPECIFIED DIMENSIONS ARE IN INCHES. TOLERANCES ARE AS LISTED. MUST BE FREE FROM BURRS AND SHARP EDGES	TOLERANCES	.XX ±.03	THIS DOCUMENT IS THE CONFIDENTIAL PROPERTY OF OTTO ENGINEERING, INC. IT IS NOT TO BE USED IN ANY WAY DETRIMENTAL TO THE INTERESTS OF OTTO ENGINEERING, INC..	DRWN. JLW	SIZE	FSCM NO	DRAWING NO.	REV.
		.XXX ±.010		CHKD. MRM	C	21649	JHT-_____	G
		ANGLES ±2°		APPD. AH	THIRD ANGLE PROJECTION	Scale 1:1	Sheet 2 OF 4	

OPTION AA

OPTION BB

OPTION CC

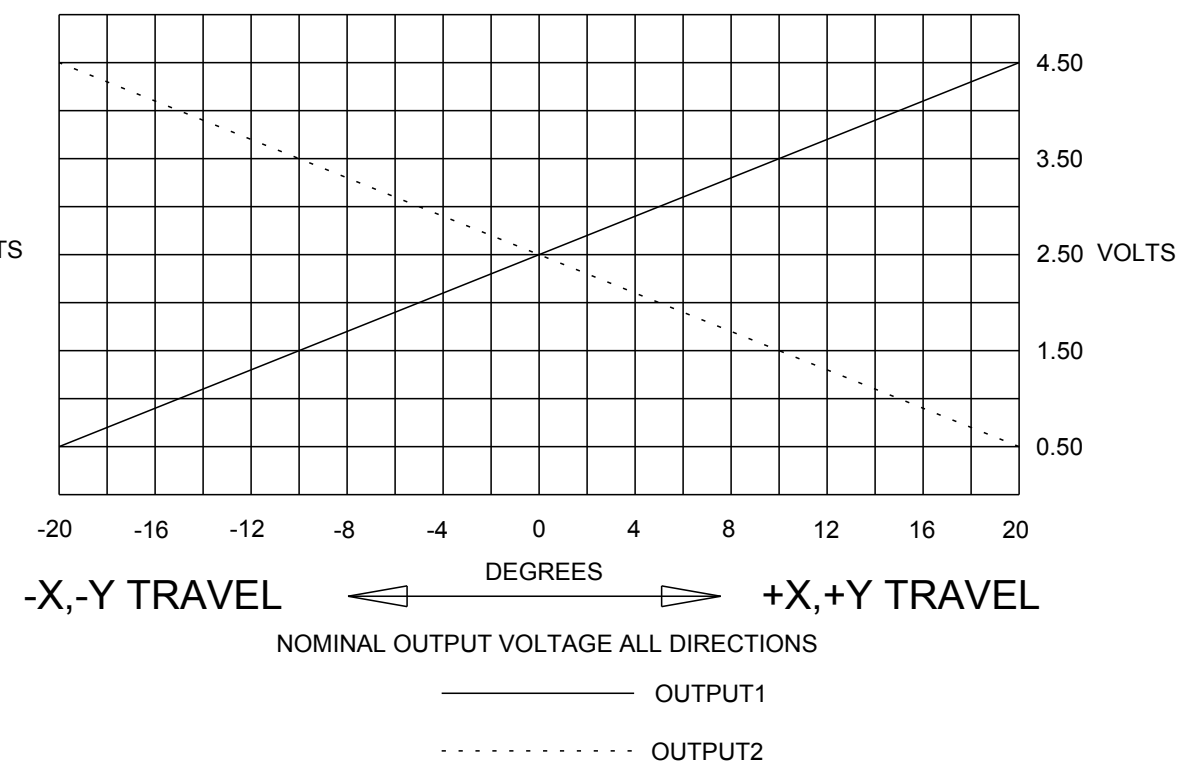
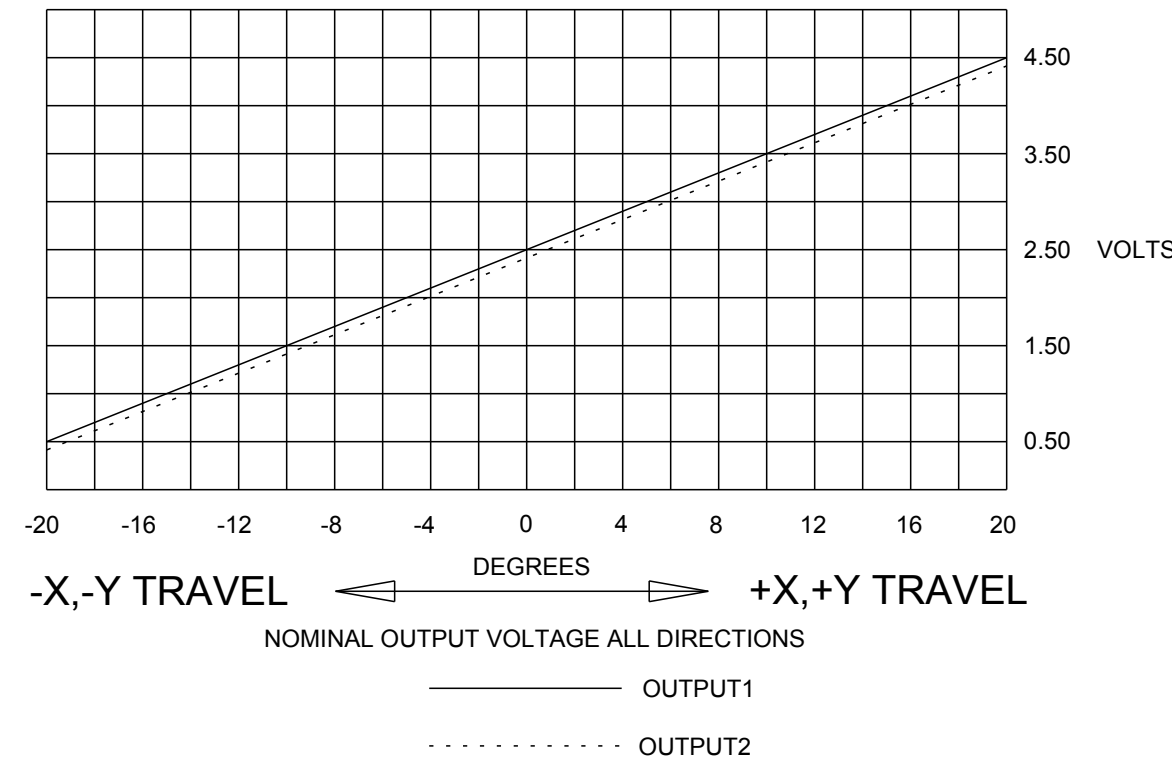
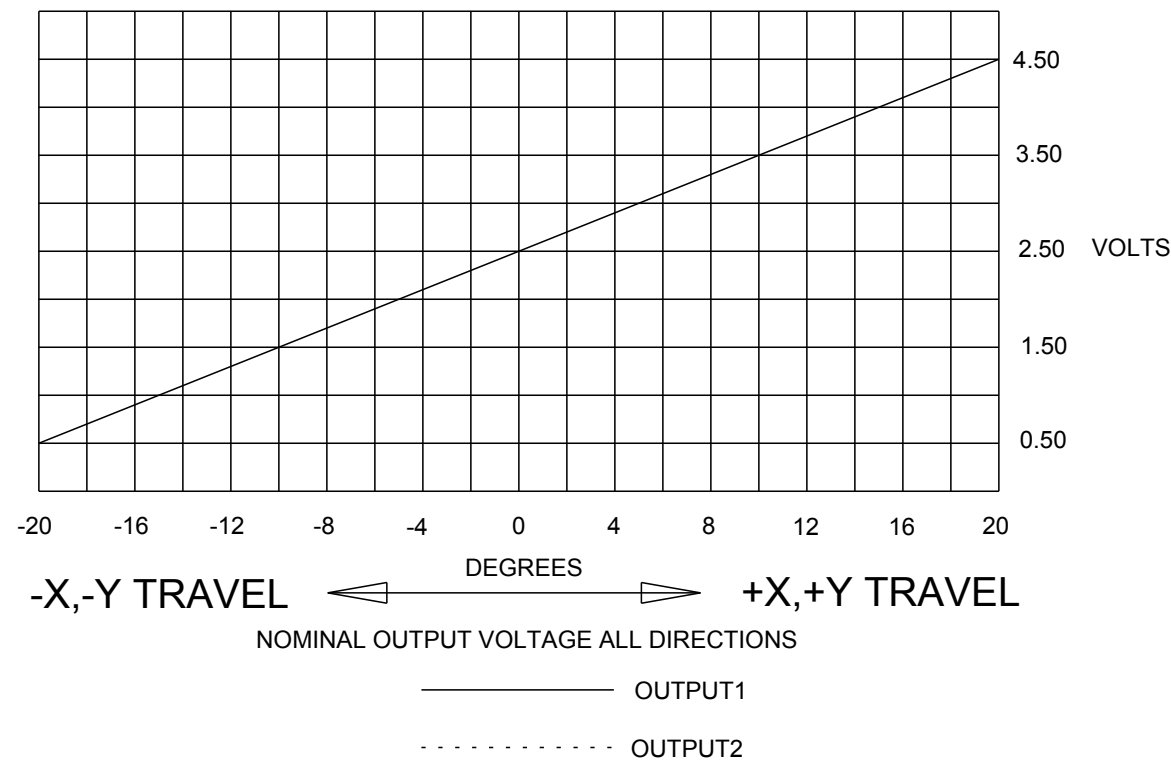

OPTION DD

OPTION EE

OPTION FF

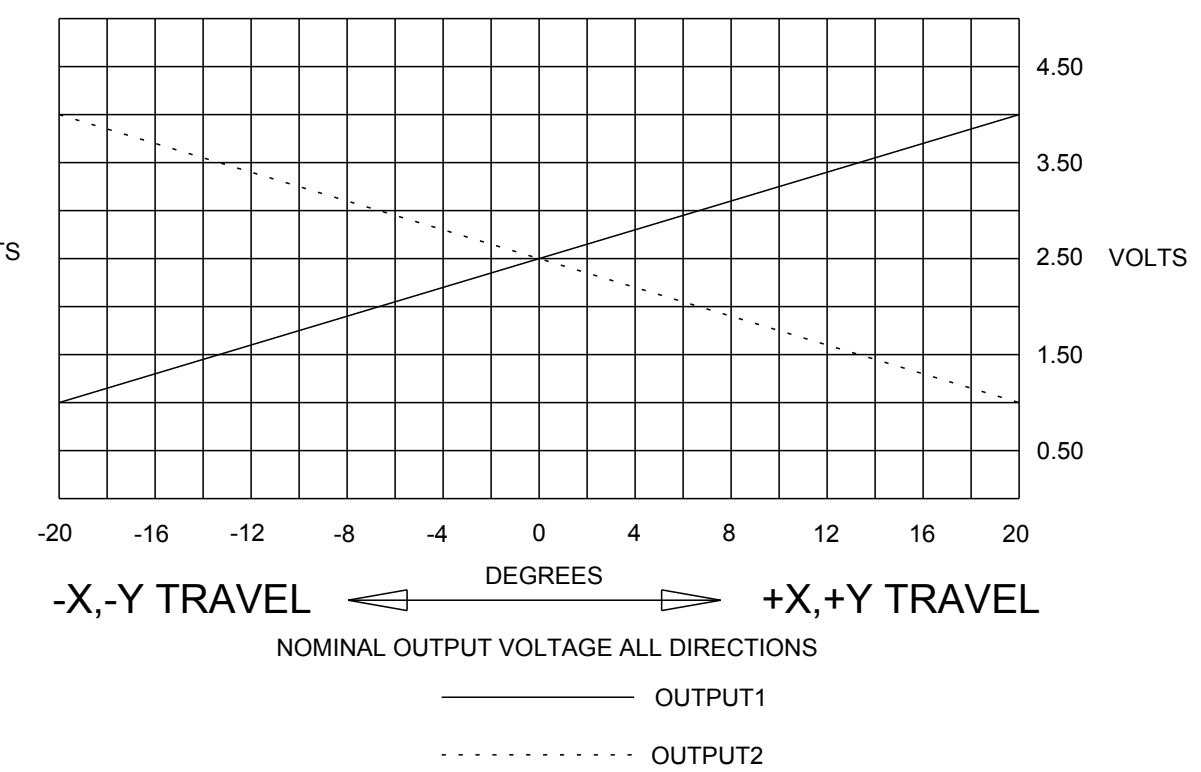
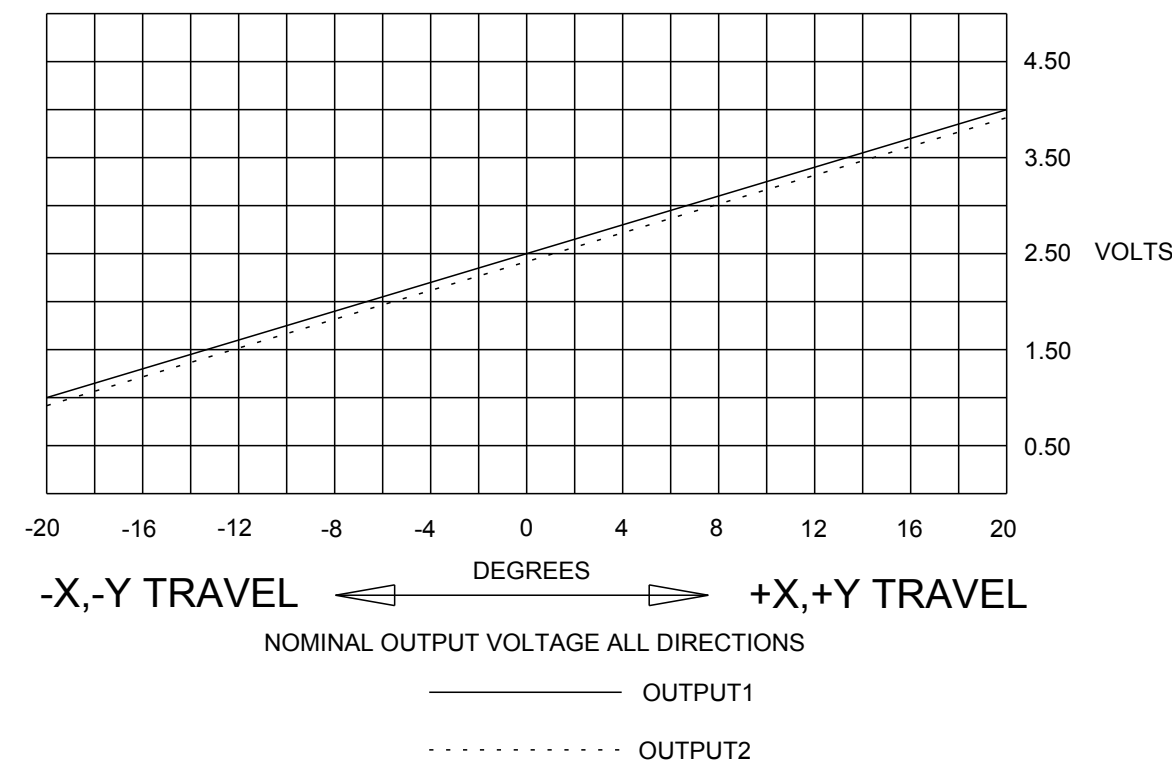
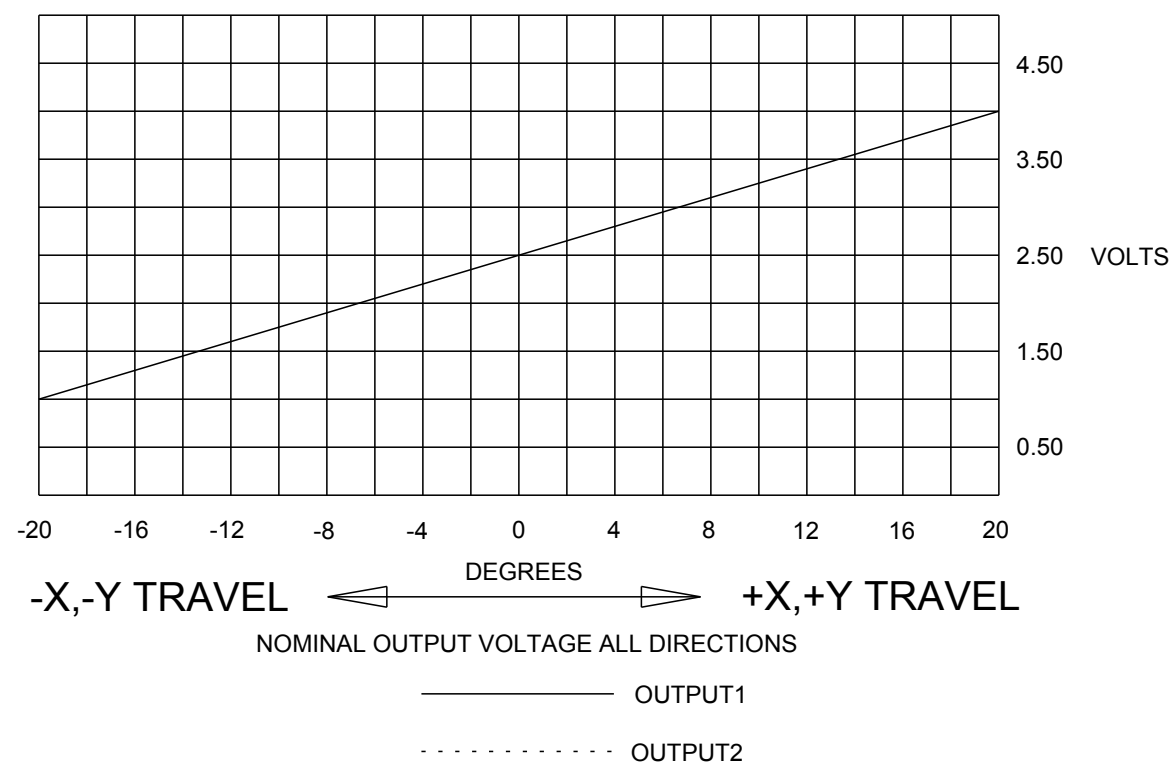

OPTION GG

OPTION HH

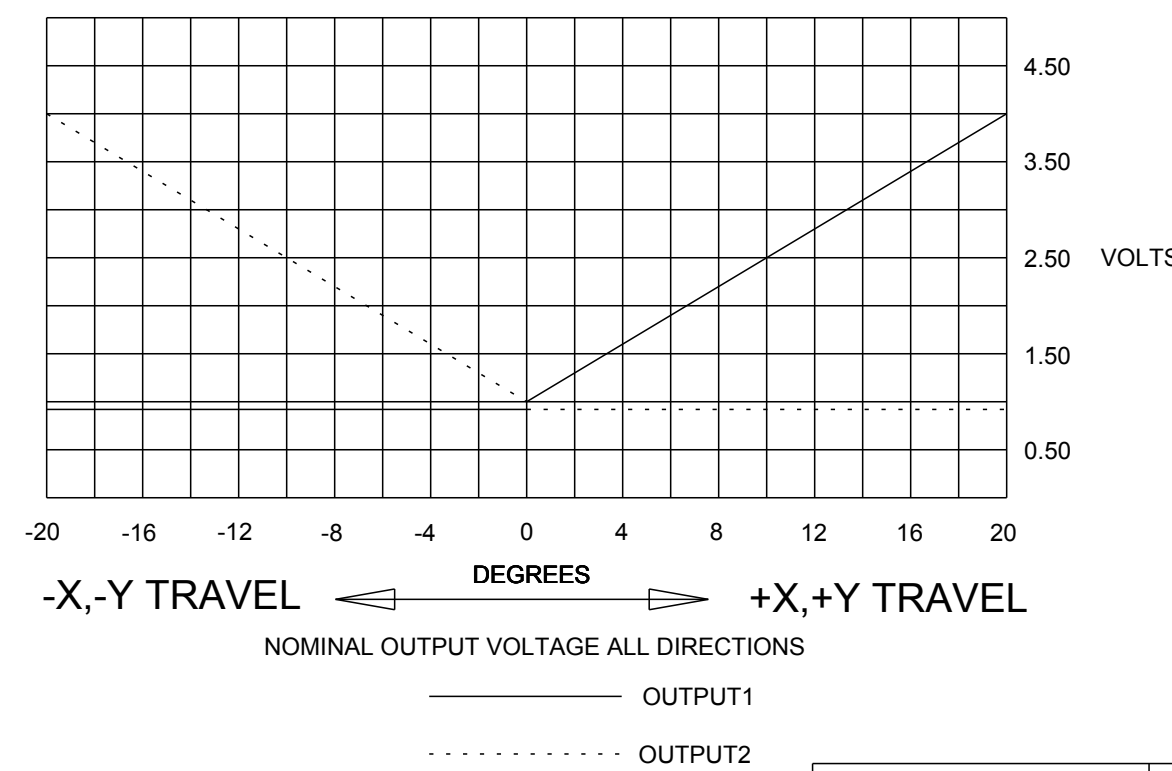
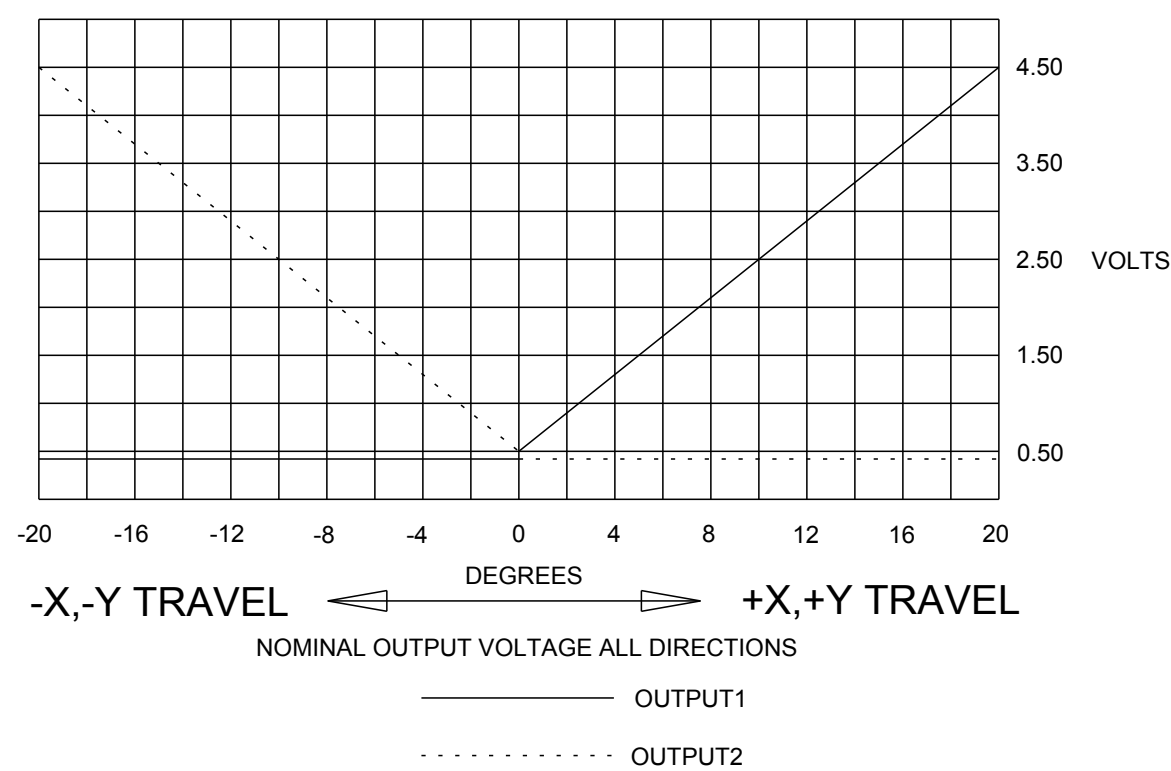

UNLESS OTHERWISE SPECIFIED
DIMENSIONS ARE IN INCHES.
TOLERANCES ARE AS LISTED.
MUST BE FREE FROM BURRS
AND SHARP EDGES

TOLERANCES
.XX ±.03
.XXX ±.010
ANGLES ±2°
DO NOT SCALE DRAWING

THIS DOCUMENT IS THE CONFIDENTIAL
PROPERTY OF OTTO ENGINEERING, INC..
IT IS NOT TO BE USED IN ANY WAY
DETRIMENTAL TO THE INTERESTS
OF OTTO ENGINEERING, INC..

DRWN. JLW
CHKD. MRM
APPD. AH
WT.

SIZE
C

FSCM NO
21649

DRAWING NO.
JHT-_____

REV.
G

THIRD ANGLE
PROJECTION

Scale 1:1

Sheet 3 OF 4

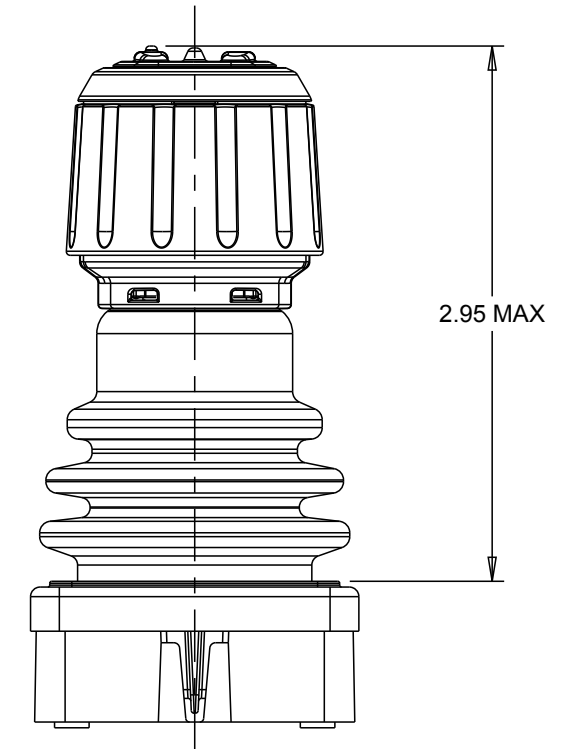
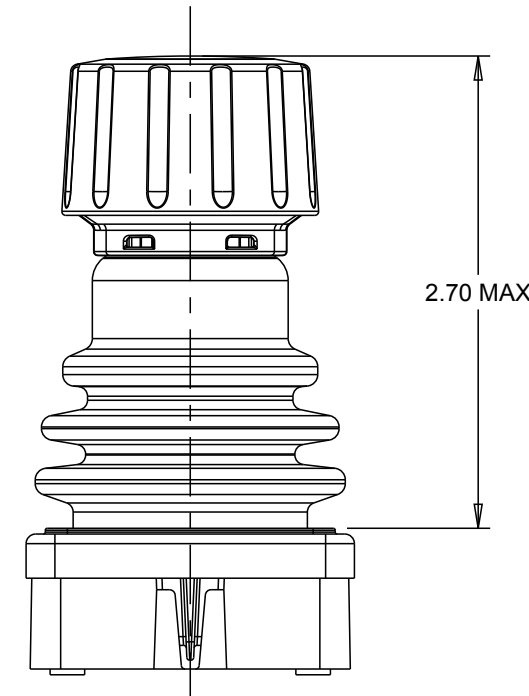
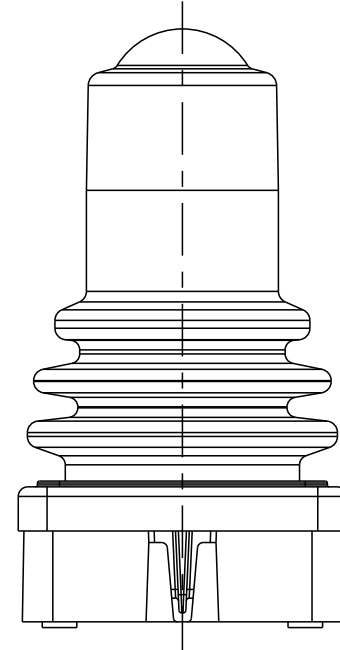
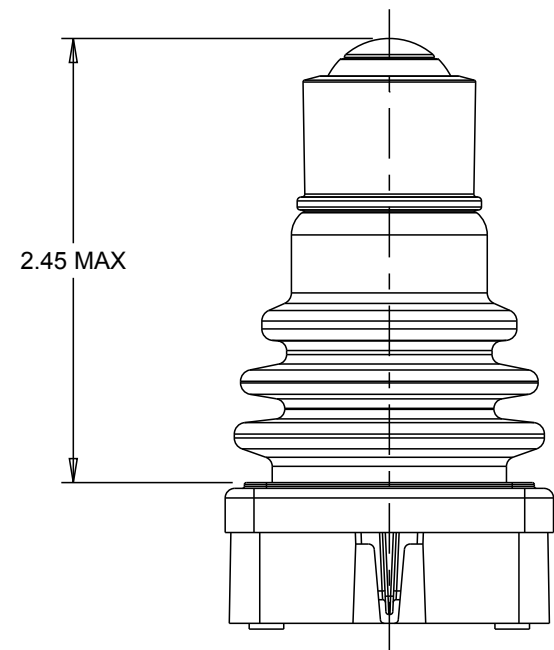
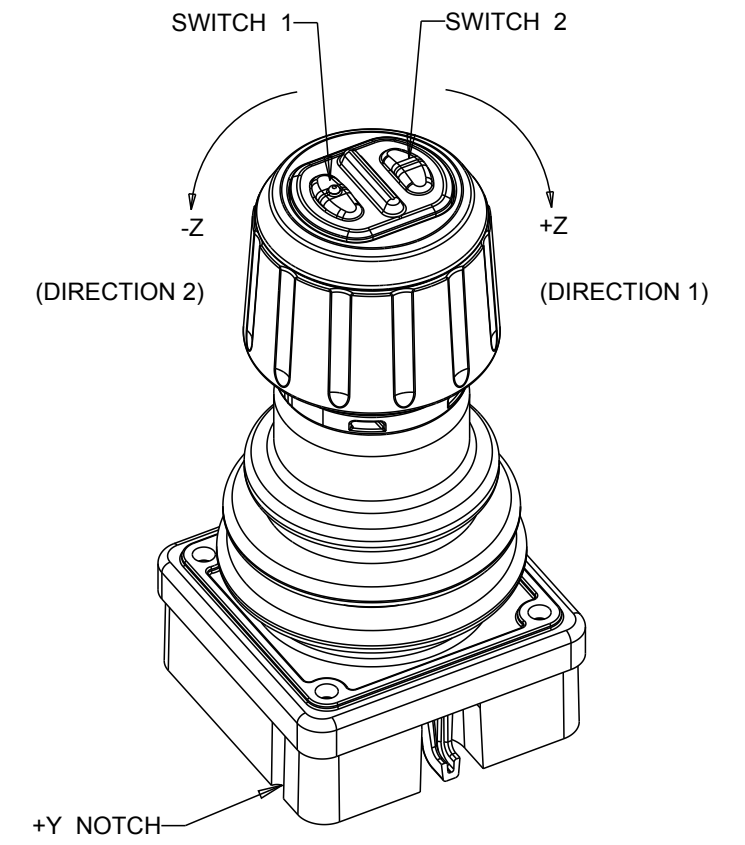
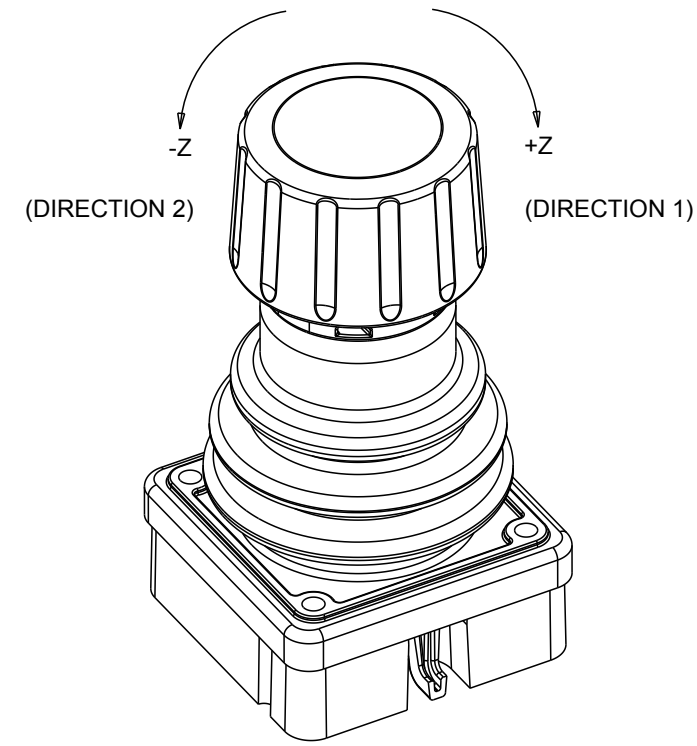
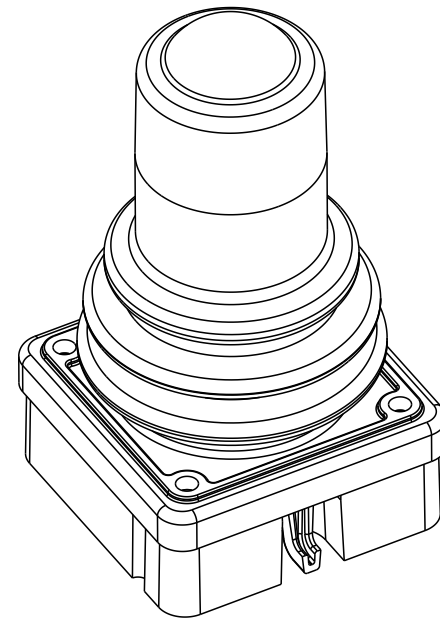
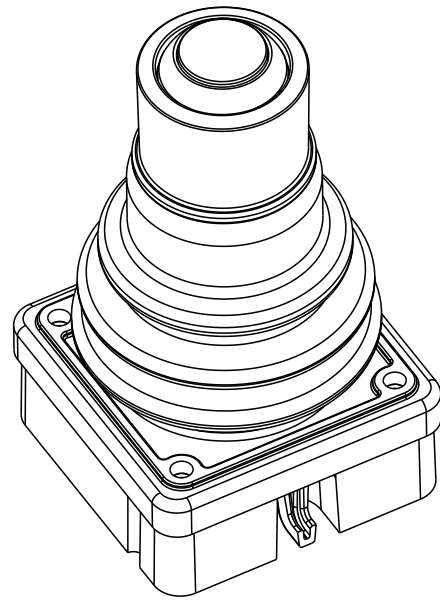

HALF BOOT

FULL BOOT

Z AXIS

Z AXIS WITH
PUSHBUTTONS

SWITCH / STYLE BOOT CONFIGURATION

UNLESS OTHERWISE SPECIFIED DIMENSIONS ARE IN INCHES. TOLERANCES ARE AS LISTED. MUST BE FREE FROM BURRS AND SHARP EDGES	TOLERANCES		THIS DOCUMENT IS THE CONFIDENTIAL PROPERTY OF OTTO ENGINEERING, INC.. IT IS NOT TO BE USED IN ANY WAY DETRIMENTAL TO THE INTERESTS OF OTTO ENGINEERING, INC..	DRWN. JLW	SIZE	FSCM NO	DRAWING NO.	REV.
	.XX	±.03		CHKD. MRM	C	21649	JHT-_____	G
	.XXX	±.010		APPD. AH				
	ANGLES ±2°	DO NOT SCALE DRAWING				THIRD ANGLE PROJECTION	Scale 1:1	Sheet 4 OF 4



Компания «ЭлектроПласт» предлагает заключение долгосрочных отношений при поставках импортных электронных компонентов на взаимовыгодных условиях!

Наши преимущества:

- Оперативные поставки широкого спектра электронных компонентов отечественного и импортного производства напрямую от производителей и с крупнейших мировых складов;
- Поставка более 17-ти миллионов наименований электронных компонентов;
- Поставка сложных, дефицитных, либо снятых с производства позиций;
- Оперативные сроки поставки под заказ (от 5 рабочих дней);
- Экспресс доставка в любую точку России;
- Техническая поддержка проекта, помощь в подборе аналогов, поставка прототипов;
- Система менеджмента качества сертифицирована по Международному стандарту ISO 9001;
- Лицензия ФСБ на осуществление работ с использованием сведений, составляющих государственную тайну;
- Поставка специализированных компонентов (Xilinx, Altera, Analog Devices, Intersil, Interpoint, Microsemi, Aeroflex, Peregrine, Syfer, Eurofarad, Texas Instrument, Miteq, Cobham, E2V, MA-COM, Hittite, Mini-Circuits, General Dynamics и др.);

Помимо этого, одним из направлений компании «ЭлектроПласт» является направление «Источники питания». Мы предлагаем Вам помощь Конструкторского отдела:

- Подбор оптимального решения, техническое обоснование при выборе компонента;
- Подбор аналогов;
- Консультации по применению компонента;
- Поставка образцов и прототипов;
- Техническая поддержка проекта;
- Защита от снятия компонента с производства.



Как с нами связаться

Телефон: 8 (812) 309 58 32 (многоканальный)

Факс: 8 (812) 320-02-42

Электронная почта: org@eplast1.ru

Адрес: 198099, г. Санкт-Петербург, ул. Калинина, дом 2, корпус 4, литера А.