

## GENERAL DESCRIPTION

The 874005-04 is a high performance Differential-to-LVDS Jitter Attenuator designed for use in PCI Express systems. In some PCI Express systems, such as those found in desktop PCs, the PCI Express clocks are generated from a low bandwidth, high phase noise PLL frequency synthesizer. In these systems, a jitter attenuator may be required to attenuate high frequency random and deterministic jitter components from the PLL synthesizer and from the system board. The 874005-04 has 2 PLL bandwidth modes: 300kHz and 2MHz. The 300kHz mode will provide maximum jitter attenuation, but higher PLL tracking skew and spread spectrum modulation from the motherboard synthesizer may be attenuated. The 2MHz bandwidth provides the best tracking skew and will pass most spread profiles. The 874005-04 supports Serdes reference clock frequencies of 100MHz, 125MHz and 250MHz.

The 874005-04 uses IDT's 3<sup>rd</sup> Generation FemtoClock™ PLL technology to achieve the lowest possible phase noise. The device is packaged in a 24 Lead TSSOP package, making it ideal for use in space constrained applications such as PCI Express add-in cards.

## BLOCK DIAGRAM

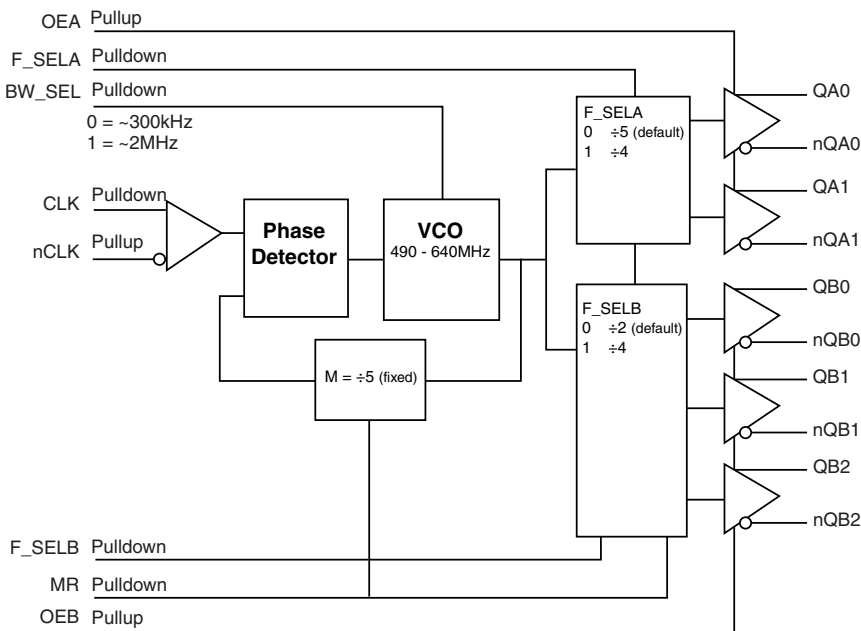

## FEATURES

- Five differential LVDS output pairs
- One differential clock input
- Supports 100MHz, 125MHz, and 250MHz Serdes reference clocks
- CLK and nCLK supports the following input types: LVPECL, LVDS, LVHSTL, SSTL, HCSL
- Output frequency range: 98MHz - 320MHz
- Input frequency range: 98MHz - 128MHz
- PCI Express (2.5 Gb/S) and Gen 2 (5 Gb/s) jitter compliant
- RMS phase jitter @ 100MHz (1.875MHz – 20MHz): 0.88ps (typical)
- VCO range: 490MHz - 640MHz
- Cycle-to-cycle jitter: 35ps (maximum) QA = QB = ÷4
- 3.3V operating supply
- Two bandwidth modes allow the system designer to make jitter attenuation/tracking skew design trade-offs
- 0°C to 70°C ambient operating temperature
- Available in lead-free (RoHS 6) package

### PLL BANDWIDTH

<b>BW_SEL</b>
0 = PLL Bandwidth: ~300kHz (default)
1 = PLL Bandwidth: ~2MHz

## PIN ASSIGNMENT

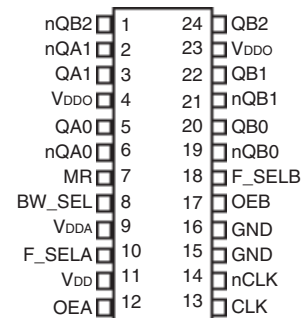

### 874005-04 24-Lead TSSOP

4.40mm x 7.8mm x 0.925mm package body  
**G Package**  
Top View

**TABLE 1. PIN DESCRIPTIONS**

Number	Name	Type		Description
1, 24	nQB2, QB2	Output		Differential output pair. LVDS interface levels.
2, 3	nQA1, QA1	Output		Differential output pair. LVDS interface levels.
4, 23	V <sub>DDO</sub>	Power		Output supply pins.
5, 6	QA0, nQA0	Output		Differential output pair. LVDS interface levels.
7	MR	Input	Pulldown	Active HIGH Master Reset. When logic HIGH, the internal dividers are reset causing the true outputs (Qx) to go low and the inverted outputs (nQx) to go high. When logic LOW, the internal dividers and the outputs are enabled. LVCMOS/LVTTL interface levels.
8	BW_SEL	Input	Pulldown	PLL bandwidth input. See Table 3B. LVCMOS/LVTTL interface levels.
9	V <sub>DDA</sub>	Power		Analog supply pin.
10	F_SELA	Input	Pulldown	Frequency select pin for QAx/nQAx outputs. See Table 3C. LVCMOS/LVTTL interface levels.
11	V <sub>DD</sub>	Power		Core supply pin.
12	OEA	Input	Pullup	Output enable pin for QA pins. When HIGH, the QAx/nQAx outputs are active. When LOW, the QAx/nQAx outputs are in a high impedance state. LVCMOS/LVTTL interface levels. See Table 3A.
13	CLK	Input	Pulldown	Non-inverting differential clock input.
14	nCLK	Input	Pullup	Inverting differential clock input.
15, 16	GND	Power		Power supply ground.
17	OEB	Input	Pullup	Output enable pin for QB pins. When HIGH, the QBx/nQBx outputs are active. When LOW, the QBx/nQBx outputs are in a high impedance state. LVCMOS/LVTTL interface levels. See Table 3A.
18	F_SELB	Input	Pulldown	Frequency select pin for QBx/nQBx outputs. See Table 3C. LVCMOS/LVTTL interface levels.
19, 20	nQB0, QB0	Output		Differential output pair. LVDS interface levels.
21, 22	nQB1, QB1	Output		Differential output pair. LVDS interface levels.

NOTE: *Pullup* and *Pulldown* refer to internal input resistors. See Table 2, Pin Characteristics, for typical values.

**TABLE 2. PIN CHARACTERISTICS**

Symbol	Parameter	Test Conditions	Minimum	Typical	Maximum	Units
C <sub>IN</sub>	Input Capacitance			4		pF
R <sub>PULLUP</sub>	Input Pullup Resistor			51		kΩ
R <sub>PULLDOWN</sub>	Input Pulldown Resistor			51		kΩ

**TABLE 3A. OUTPUT ENABLE FUNCTION TABLE**

Inputs		Outputs	
OEA/OEB		QAx/nQAx	QBx/nQBx
0		High Impedance	High Impedance
1		Enabled	Enabled

**TABLE 3B. PLL BANDWIDTH CONTROL,  $f_{REF} = 100\text{MHz}$** 

Inputs		PLL Bandwidth
BW_SEL		
0		~300kHz (default)
1		~2MHz

**TABLE 3C. OUTPUT FREQUENCY FOR INPUT FREQUENCY = 100MHz**

Inputs		Outputs	
F_SELA	F_SELB	QAx/nQAx	QBx/nQBx
0 (default)	0 (default)	VCO/5, 100MHz	VCO/2, 250MHz
0	1	VCO/5, 100MHz	VCO/4, 125MHz
1	0	VCO/4, 125MHz	VCO/2, 250MHz
1	1	VCO/4, 125MHz	VCO/4, 125MHz

**ABSOLUTE MAXIMUM RATINGS**

Supply Voltage, $V_{DD}$	4.6V
Inputs, $V_I$	-0.5V to $V_{DD} + 0.5\text{V}$
Outputs, $V_O$	-0.5V to $V_{DDO} + 0.5\text{V}$
Package Thermal Impedance, $\theta_{JA}$	82.3°C/W (0 mps)
Storage Temperature, $T_{STG}$	-65°C to 150°C

NOTE: Stresses beyond those listed under Absolute Maximum Ratings may cause permanent damage to the device. These ratings are stress specifications only. Functional operation of product at these conditions or any conditions beyond those listed in the *DC Characteristics* or *AC Characteristics* is not implied. Exposure to absolute maximum rating conditions for extended periods may affect product reliability.

**TABLE 4A. POWER SUPPLY DC CHARACTERISTICS,  $V_{DD} = V_{DDO} = 3.3\text{V} \pm 5\%$ ,  $T_A = 0^\circ\text{C}$  TO  $70^\circ\text{C}$** 

Symbol	Parameter	Test Conditions	Minimum	Typical	Maximum	Units
$V_{DD}$	Core Supply Voltage		3.135	3.3	3.465	V
$V_{DDA}$	Analog Supply Voltage		$V_{DD} - 0.10$	3.3	$V_{DD}$	V
$V_{DDO}$	Output Supply Voltage		3.135	3.3	3.465	V
$I_{DD}$	Power Supply Current				80	mA
$I_{DDA}$	Analog Supply Current				10	mA
$I_{DDO}$	Output Supply Current				75	mA

**TABLE 4C. DIFFERENTIAL DC CHARACTERISTICS,  $V_{DD} = V_{DDO} = 3.3V \pm 5\%$ ,  $T_A = 0^\circ C$  TO  $70^\circ C$** 

Symbol	Parameter	Test Conditions	Minimum	Typical	Maximum	Units
$I_{IH}$	Input High Current	CLK	$V_{DD} = V_{IN} = 3.465V$		150	$\mu A$
		nCLK	$V_{DD} = V_{IN} = 3.465V$		5	$\mu A$
$I_{IL}$	Input Low Current	CLK	$V_{DD} = V_{IN} = 3.465V$	-5		$\mu A$
		nCLK	$V_{DD} = V_{IN} = 3.465V$	-150		$\mu A$
$V_{PP}$	Peak-to-Peak Input Voltage; NOTE 1		0.15		1.3	V
$V_{CMR}$	Common Mode Input Voltage; NOTE 1, 2		GND + 0.5		$V_{DD} - 0.85$	V

 NOTE 1:  $V_{IL}$  should not be less than -0.3V.

 NOTE 2: Common mode voltage is defined as  $V_{IH}$ .

**TABLE 4D. LVDS DC CHARACTERISTICS,  $V_{DD} = V_{DDO} = 3.3V \pm 5\%$ ,  $T_A = 0^\circ C$  TO  $70^\circ C$** 

Symbol	Parameter	Test Conditions	Minimum	Typical	Maximum	Units
$V_{OD}$	Differential Output Voltage		247		454	mV
$\Delta V_{OD}$	$V_{OD}$ Magnitude Change				50	mV
$V_{OS}$	Offset Voltage		1.125	1.25	1.375	V
$\Delta V_{OS}$	$V_{OS}$ Magnitude Change				50	mV

**TABLE 5. AC CHARACTERISTICS,  $V_{DD} = V_{DDO} = 3.3V \pm 5\%$ ,  $T_A = 0^\circ C$  TO  $70^\circ C$** 

Symbol	Parameter	Test Conditions	Minimum	Typical	Maximum	Units
$f_{MAX}$	Output Frequency		98		320	MHz
$f_{jit}(\theta)$	RMS Phase Jitter (Random); NOTE 1	100MHz, Integration Range: (1.875MHz – 20MHz)		0.88		ps
$f_{jit}(cc)$	Cycle-to-Cycle Jitter, NOTE 2	QA, QB = $\div 4$			35	ps
		QA = $\div 5$			75	ps
$t_{sk}(o)$	Output Skew; NOTE 3				90	ps
$t_{sk}(b)$	Bank Skew: NOTE 4	QAx			15	ps
		QBx			68	ps
$t_R / t_F$	Output Rise/Fall Time	20% to 80%	300		500	ps
odc	Output Duty Cycle		48		52	%

NOTE 1: Please refer to the Phase Noise Plot.

NOTE 2: This parameter is defined in accordance with JEDEC Standard 65.

NOTE 3: Defined as skew between outputs at the same supply voltage and frequency, and with equal load conditions. Measured at the differential cross points.

NOTE 4: Defined as skew within a bank of outputs at the same supply voltage and frequency, and with equal load conditions.

## PARAMETER MEASUREMENT INFORMATION

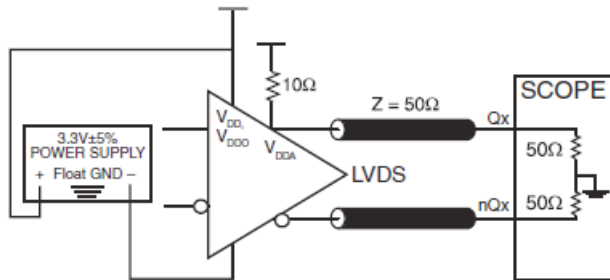
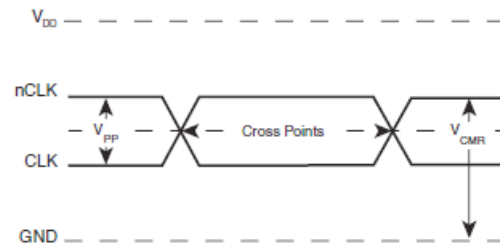
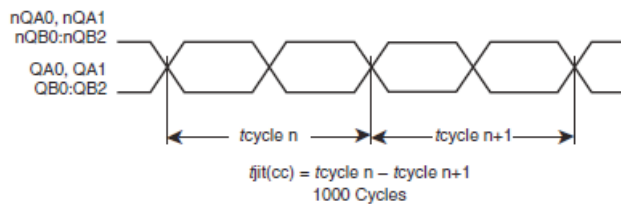
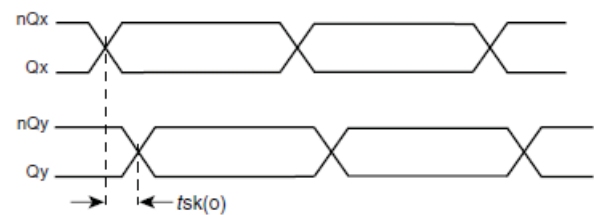
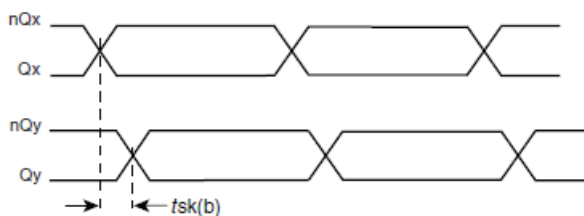
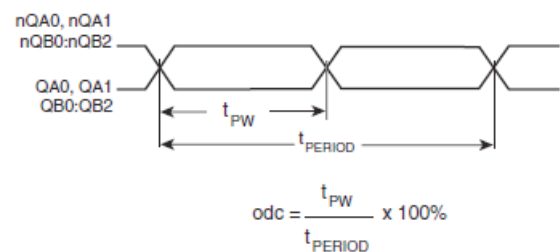
**3.3V LVDS OUTPUT LOAD AC TEST CIRCUIT**

**DIFFERENTIAL INPUT LEVEL**

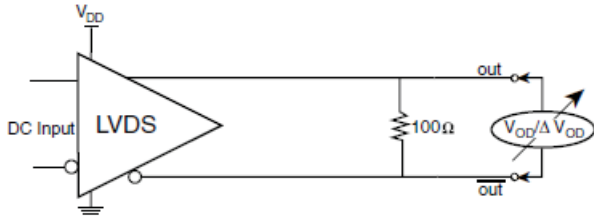
**CYCLE-TO-CYCLE JITTER**

**OUTPUT SKEW**

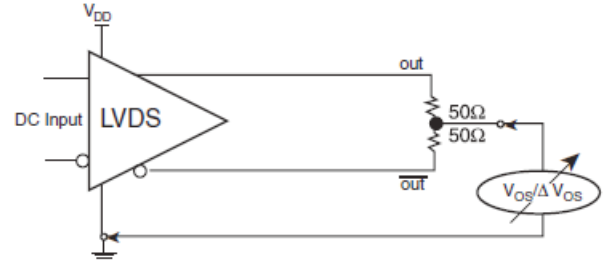
**BANK SKEW**

**OUTPUT DUTY CYCLE/PULSE WIDTH/PERIOD**

## PARAMETER MEASUREMENT INFORMATION, CONTINUED



**DIFFERENTIAL OUTPUT VOLTAGE SETUP**



**OFFSET VOLTAGE SETUP**

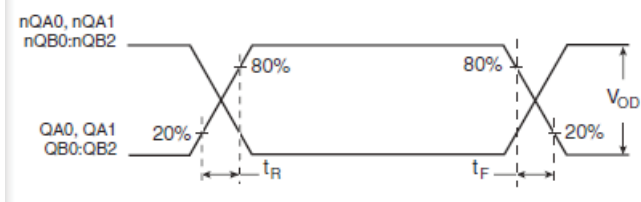

**OUTPUT RISE/FALL TIME**

## APPLICATION INFORMATION

### POWER SUPPLY FILTERING TECHNIQUES

As in any high speed analog circuitry, the power supply pins are vulnerable to random noise. To achieve optimum jitter performance, power supply isolation is required. The 874005-04 provides separate power supplies to isolate any high switching noise from the outputs to the internal PLL.  $V_{DD}$ ,  $V_{DDA}$  and  $V_{DDO}$  should be individually connected to the power supply plane through vias, and  $0.01\mu\text{F}$  bypass capacitors should be used for each pin. *Figure 1* illustrates this for a generic  $V_{DD}$  pin and also shows that  $V_{DDA}$  requires that an additional  $10\Omega$  resistor along with a  $10\mu\text{F}$  bypass capacitor be connected to the  $V_{DDA}$  pin.

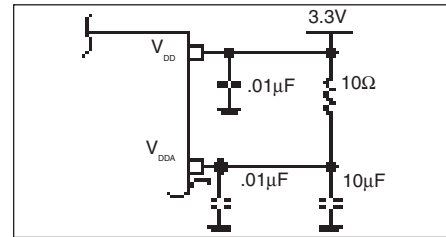

FIGURE 1. POWER SUPPLY FILTERING

### RECOMMENDATIONS FOR UNUSED INPUT AND OUTPUT PINS

#### INPUTS:

##### LVC MOS CONTROL PINS

All control pins have internal pull-ups or pull-downs; additional resistance is not required but can be added for additional protection. A  $1\text{k}\Omega$  resistor can be used.

#### OUTPUTS:

##### LVDS OUTPUTS

All unused LVDS output pairs can be either left floating or terminated with  $100\Omega$  across. If they are left floating, we recommend that there is no trace attached.

### WIRING THE DIFFERENTIAL INPUT TO ACCEPT SINGLE ENDED LEVELS

*Figure 2* shows how the differential input can be wired to accept single ended levels. The reference voltage  $V_{REF} = V_{DD}/2$  is generated by the bias resistors  $R1$ ,  $R2$  and  $C1$ . This bias circuit should be located as close as possible to the input pin. The ratio

of  $R1$  and  $R2$  might need to be adjusted to position the  $V_{REF}$  in the center of the input voltage swing. For example, if the input clock swing is only  $2.5\text{V}$  and  $V_{DD} = 3.3\text{V}$ ,  $V_{REF}$  should be  $1.25\text{V}$  and  $R2/R1 = 0.609$ .

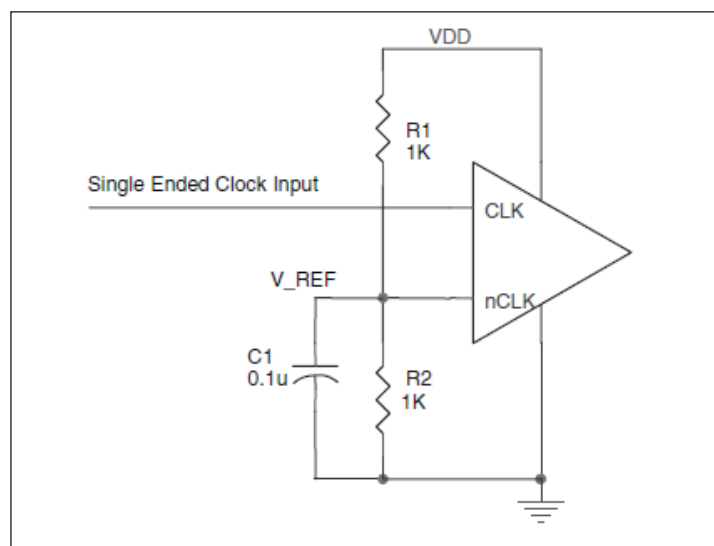
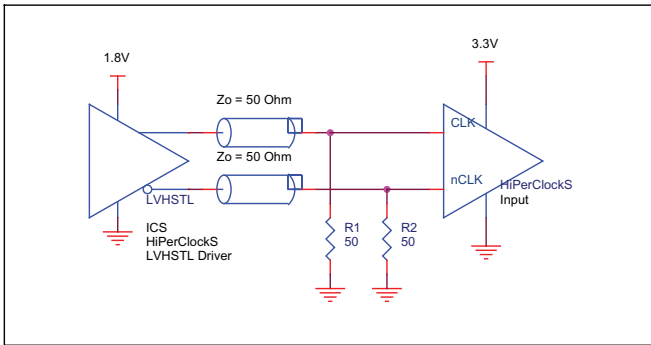

FIGURE 2. SINGLE ENDED SIGNAL DRIVING DIFFERENTIAL INPUT

## DIFFERENTIAL CLOCK INPUT INTERFACE

The CLK /nCLK accepts LVDS, LVPECL and LVHSTL and other differential signals. Both signals must meet the  $V_{PP}$  and  $V_{CMR}$  input requirements. Figures 3A to 3F show interface examples for the HiPerClockS CLK/nCLK input driven by the most common driver types. The input interfaces suggested here are examples only.

Please consult with the vendor of the driver component to confirm the driver termination requirements. For example in Figure 3A, the input termination applies for IDT HiPerClockS open emitter LVHSTL drivers. If you are using an LVHSTL driver from another vendor, use their termination recommendation.



**FIGURE 3A. HiPerClockS CLK/nCLK INPUT DRIVEN BY AN IDT OPEN EMITTER HiPerClockS LVHSTL DRIVER**

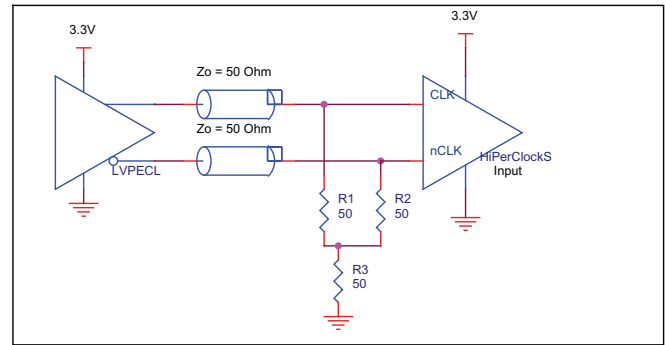

**FIGURE 3B. HiPerClockS CLK/nCLK INPUT DRIVEN BY A 3.3V LVPECL DRIVER**

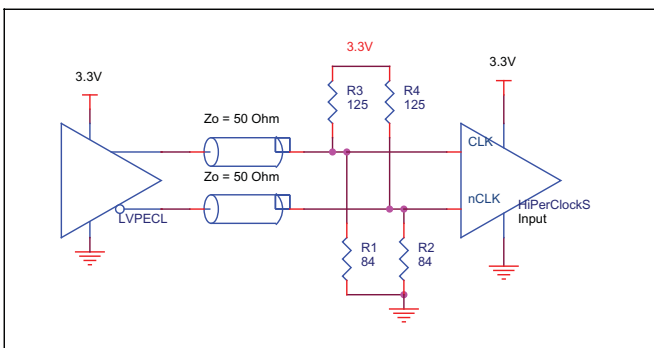

**FIGURE 3C. HiPerClockS CLK/nCLK INPUT DRIVEN BY A 3.3V LVPECL DRIVER**

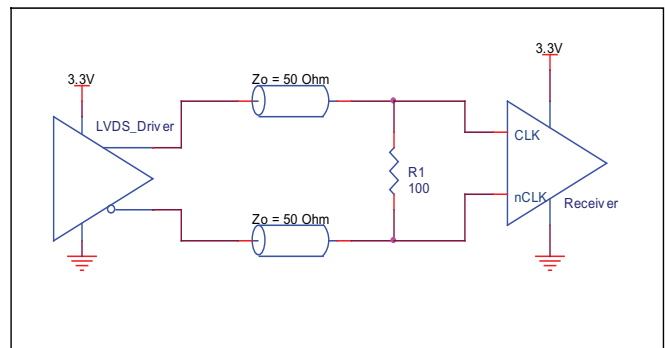

**FIGURE 3D. HiPerClockS CLK/nCLK INPUT DRIVEN BY A 3.3V LVDS DRIVER**

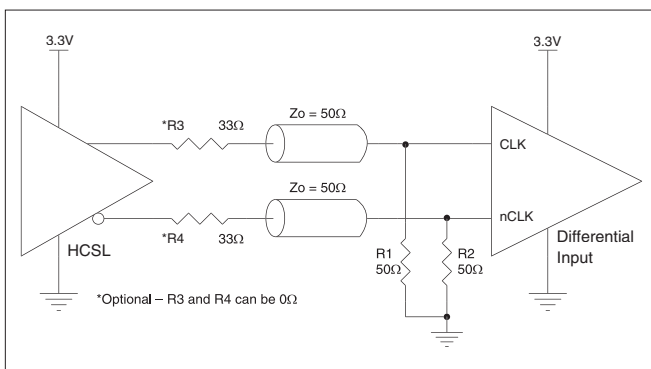

**FIGURE 3E. HiPerClockS CLK/nCLK INPUT DRIVEN BY A 3.3V HCSL DRIVER**

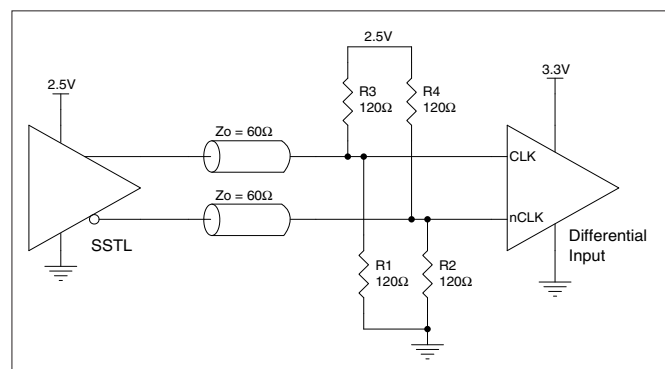

**FIGURE 3F. HiPerClockS CLK/nCLK INPUT DRIVEN BY A 2.5V SSTL DRIVER**



## LVDS DRIVER TERMINATION

A general LVDS interface is shown in *Figure 4*. In a 100Ω differential transmission line environment, LVDS drivers require a matched load termination of 100Ω across near

the receiver input. For a multiple LVDS output buffer, if only partial outputs are used, it is recommended to terminate the unused outputs.

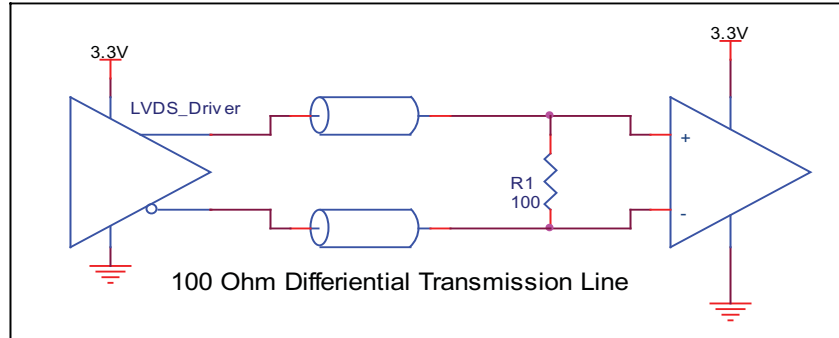

FIGURE 4. TYPICAL LVDS DRIVER TERMINATION

## SCHEMATIC EXAMPLE

*Figure 5* shows an example of 874005-04 application schematic. In this example, the device is operated at  $V_{DD} = 3.3V$ . The

decoupling capacitor should be located as close as possible to the power pin. The input is driven by a 3.3V LVPECL driver.

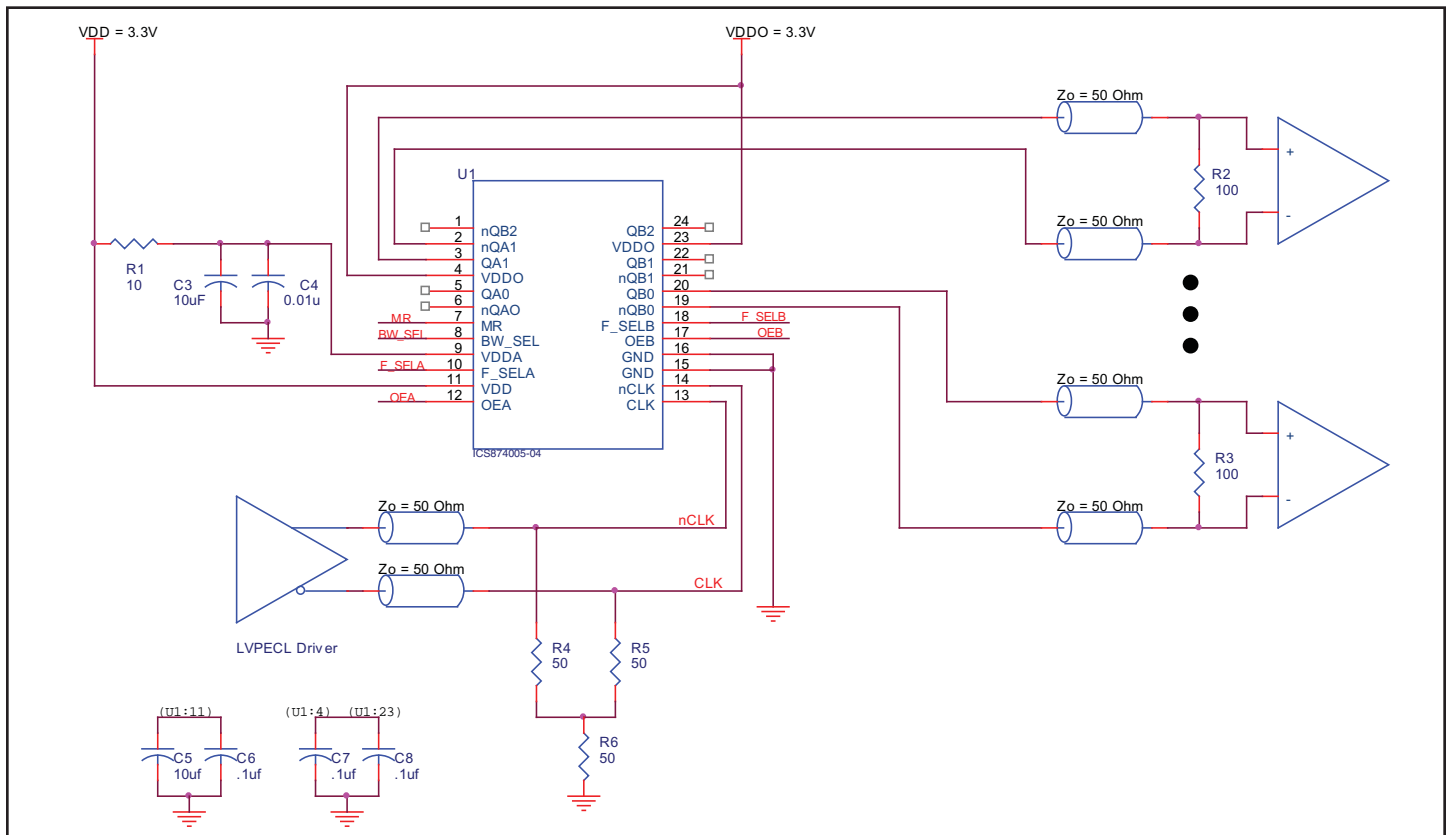

FIGURE 5. 874005-04 SCHEMATIC EXAMPLE

## POWER CONSIDERATIONS

This section provides information on power dissipation and junction temperature for the 874005-04. Equations and example calculations are also provided.

### 1. Power Dissipation (typical).

The total power dissipation for the 874005-04 is the sum of the core power plus the analog power plus the power dissipated in the load(s). The following is the power dissipation for  $V_{DD} = 3.3V + 5\% = 3.465V$ , which gives worst case results.

- Power (core)<sub>MAX</sub> =  $V_{DD\_MAX} * (I_{DD\_MAX} + I_{DDA\_MAX}) = 3.465V * (80mA + 10mA) = \mathbf{311.85mW}$

- Power (outputs)<sub>MAX</sub> =  $V_{DDO\_MAX} * I_{DDO\_MAX} = 3.465V * 75mA = \mathbf{259.875mW}$

**Total Power**<sub>MAX</sub> =  $311.85mW + 259.875mW = \mathbf{571.725mW}$

### 2. Junction Temperature (typical).

Junction temperature,  $T_j$ , is the temperature at the junction of the bond wire and bond pad and directly affects the reliability of the device. The maximum recommended junction temperature for HiPerClockS™ devices is 125°C.

The equation for  $T_j$  is as follows:  $T_j = \theta_{JA} * Pd\_total + T_A$

$T_j$  = Junction Temperature

$\theta_{JA}$  = Junction-to-Ambient Thermal Resistance

$Pd\_total$  = Total Device Power Dissipation (example calculation is in section 1 above)

$T_A$  = Ambient Temperature

In order to calculate junction temperature, the appropriate junction-to-ambient thermal resistance  $\theta_{JA}$  must be used. Assuming no air flow and a multi-layer board, the appropriate value is 82.3°C/W per Table 6 below.

Therefore,  $T_j$  for an ambient temperature of 70°C with all outputs switching is:

$$70^\circ\text{C} + 0.572\text{W} * 82.3^\circ\text{C/W} = 117.1^\circ\text{C}. \text{ This is below the limit of } 125^\circ\text{C}.$$

This calculation is only an example.  $T_j$  will obviously vary depending on the number of loaded outputs, supply voltage, air flow, and the type of board.

**TABLE 6. THERMAL RESISTANCE  $\theta_{JA}$  FOR 24-LEAD TSSOP, FORCED CONVECTION**

$\theta_{JA}$ by Velocity (Meters per Second)			
	0	1	2.5
Multi-Layer PCB, JEDEC Standard Test Boards	82.3°C/W	78.0°C/W	75.9°C/W

## RELIABILITY INFORMATION

**TABLE 7.  $\theta_{JA}$  VS. AIR FLOW TABLE FOR 24 LEAD TSSOP**

$\theta_{JA}$ by Velocity (Meters per Second)			
	0	1	2.5
Multi-Layer PCB, JEDEC Standard Test Boards	82.3°C/W	78.0°C/W	75.9°C/W

**TRANSISTOR COUNT**

The transistor count for 874005-04 is: 1428

## PACKAGE OUTLINE AND PACKAGE DIMENSIONS

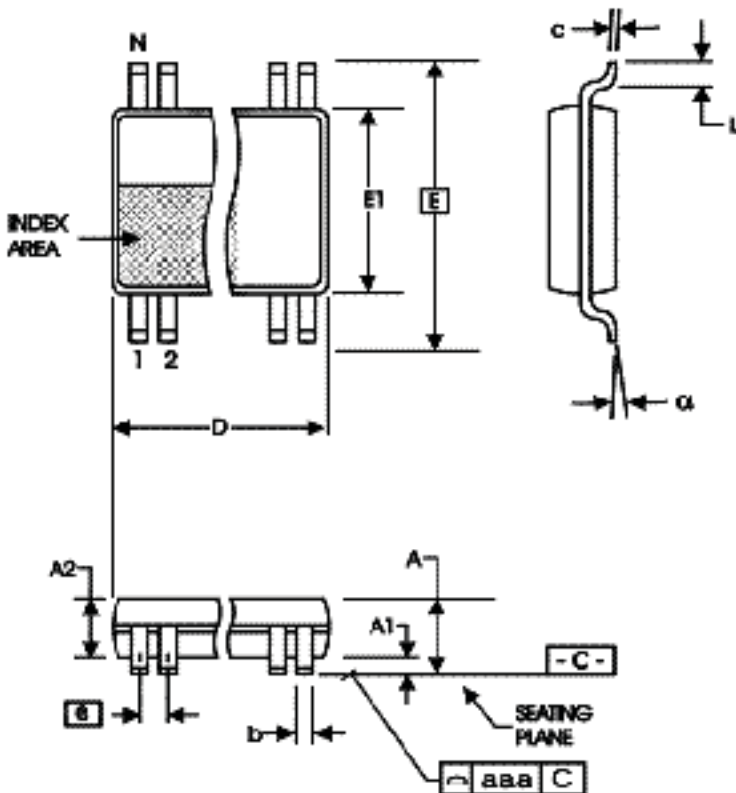
**PACKAGE OUTLINE - G SUFFIX FOR 24 LEAD TSSOP**

**TABLE 8. PACKAGE DIMENSIONS**

SYMBOL	Millimeters	
	Minimum	Maximum
N	24	
A	--	1.20
A1	0.05	0.15
A2	0.80	1.05
b	0.19	0.30
c	0.09	0.20
D	7.70	7.90
E	6.40 BASIC	
E1	4.30	4.50
e	0.65 BASIC	
L	0.45	0.75
$\alpha$	0°	8°
aaa	--	0.10

Reference Document: JEDEC Publication 95, MO-153

**TABLE 9. ORDERING INFORMATION**

<b>Part/Order Number</b>	<b>Marking</b>	<b>Package</b>	<b>Shipping Packaging</b>	<b>Temperature</b>
874005AG-04LF	ICS874005A04L	24 Lead "Lead-Free" TSSOP	tube	0°C to 70°C
874005AG-04LFT	ICS874005A04L	24 Lead "Lead-Free" TSSOP	tape & reel	0°C to 70°C

**REVISION HISTORY SHEET**

Rev	Table	Page	Description of Change	Date
	T9	1 12	Removed ICS from part numbers where needed. General Description - Deleted ICS chip. Ordering Information - removed quantity from tape and reel. Deleted LF note below table. Updated header and footer.	1/26/16



Corporate Headquarters  
6024 Silver Creek Valley Road  
San Jose, CA 95138 USA  
[www.IDT.com](http://www.IDT.com)

Sales  
1-800-345-7015 or 408-284-8200  
Fax: 408-284-2775  
[www.IDT.com/go/sales](http://www.IDT.com/go/sales)

Tech Support  
[www.idt.com/go/support](http://www.idt.com/go/support)

DISCLAIMER Integrated Device Technology, Inc. (IDT) reserves the right to modify the products and/or specifications described herein at any time, without notice, at IDT's sole discretion. Performance specifications and operating parameters of the described products are determined in an independent state and are not guaranteed to perform the same way when installed in customer products. The information contained herein is provided without representation or warranty of any kind, whether express or implied, including, but not limited to, the suitability of IDT's products for any particular purpose, an implied warranty of merchantability, or non-infringement of the intellectual property rights of others. This document is presented only as a guide and does not convey any license under intellectual property rights of IDT or any third parties.

IDT's products are not intended for use in applications involving extreme environmental conditions or in life support systems or similar devices where the failure or malfunction of an IDT product can be reasonably expected to significantly affect the health or safety of users. Anyone using an IDT product in such a manner does so at their own risk, absent an express, written agreement by IDT.

Integrated Device Technology, IDT and the IDT logo are trademarks or registered trademarks of IDT and its subsidiaries in the United States and other countries. Other trademarks used herein are the property of IDT or their respective third party owners.

For datasheet type definitions and a glossary of common terms, visit [www.idt.com/go/glossary](http://www.idt.com/go/glossary).

Copyright ©2016 Integrated Device Technology, Inc. All rights reserved.



Компания «ЭлектроПласт» предлагает заключение долгосрочных отношений при поставках импортных электронных компонентов на взаимовыгодных условиях!

Наши преимущества:

- Оперативные поставки широкого спектра электронных компонентов отечественного и импортного производства напрямую от производителей и с крупнейших мировых складов;
- Поставка более 17-ти миллионов наименований электронных компонентов;
- Поставка сложных, дефицитных, либо снятых с производства позиций;
- Оперативные сроки поставки под заказ (от 5 рабочих дней);
- Экспресс доставка в любую точку России;
- Техническая поддержка проекта, помощь в подборе аналогов, поставка прототипов;
- Система менеджмента качества сертифицирована по Международному стандарту ISO 9001;
- Лицензия ФСБ на осуществление работ с использованием сведений, составляющих государственную тайну;
- Поставка специализированных компонентов (Xilinx, Altera, Analog Devices, Intersil, Interpoint, Microsemi, Aeroflex, Peregrine, Syfer, Eurofarad, Texas Instrument, Miteq, Cobham, E2V, MA-COM, Hittite, Mini-Circuits, General Dynamics и др.);

Помимо этого, одним из направлений компании «ЭлектроПласт» является направление «Источники питания». Мы предлагаем Вам помощь Конструкторского отдела:

- Подбор оптимального решения, техническое обоснование при выборе компонента;
- Подбор аналогов;
- Консультации по применению компонента;
- Поставка образцов и прототипов;
- Техническая поддержка проекта;
- Защита от снятия компонента с производства.



#### Как с нами связаться

**Телефон:** 8 (812) 309 58 32 (многоканальный)

**Факс:** 8 (812) 320-02-42

**Электронная почта:** [org@eplast1.ru](mailto:org@eplast1.ru)

**Адрес:** 198099, г. Санкт-Петербург, ул. Калинина, дом 2, корпус 4, литера А.