

## CSLT Series

---

### Miniature, Open-Loop Current Sensors



#### DESCRIPTION

Honeywell's CSLT Series miniature, open-loop current sensors incorporate our SS490 Series miniature ratiometric linear Hall-effect sensor (MRL™). The sensing element is encapsulated in a printed circuit board-mountable plastic package.

#### FEATURES

---

- Open-loop, through-hole design
- Output voltage isolation from input
- ac or dc current sensing
- Linear ratiometric output
- Current sinking or sourcing output for interfacing flexibility
- Fast response time
- Compact size
- Accurate, low-cost sensing
- Minimum energy dissipation
- Maximum current limited only by conductor size
- Built-in temperature compensation promotes reliable operation
- Operating temperature range -25 °C to 100 °C [-13 °F to 212 °F]
- RoHs compliant (lead-free)

The combination of sensor, flux collector and housing comprises the current sensor assembly. These sensors are ratiometric.

#### POTENTIAL APPLICATIONS

---

- Motor control in appliances, HVAC and consumer tools
- Current monitoring of electronic circuits
- Overcurrent protection
- Ground fault detectors
- Robotics
- Industrial process control
- UPS and telecommunication power supplies
- Welding current monitoring
- Battery management systems in mobile equipment
- Watt meters
- Variable speed drives

# CSLT Series

## PRODUCT SPECIFICATIONS

<b>Product type</b>	miniature hall-effect linear open-loop current sensor
<b>Package quantity/type</b>	25 per box
<b>Package style</b>	PC board mount – radial lead IC
<b>Supply voltage</b>	4.5 Vdc to 10.5 Vdc
<b>Output type</b>	sink/source
<b>Magnetic actuation type</b>	analog ratiometric

Parameter	Symbol	Min.	Typ.	Max.	Units	Condition
<b>Current range</b>	$I_p$	±100	—	—	AT	<±1.5 % error (-25 °C to 100 °C [-13 °F to 212 °F])
<b>Supply voltage</b>	$V_s$	4.5	5	10.5	V	—
<b><math>V_{out}</math> @ 0 NI</b>	$V_o$	2.35	2.5	2.65	V	—
<b>Supply current</b>	$I_s$	—	7	9	mA	no load
<b>Sensitivity</b>	$\Delta V/I$	13.5	16	18.5	mV/AT	-25 °C to 100 °C [-13 °F to 212 °F]
<b>Hysteresis</b>	—	—	—	0.5	%	±100 A
<b>Temp error - null</b>	$TC_{\Delta V_o/V_o}$	-0.064	—	0.064	%/°C	—
<b>Temp error - gain</b>	$TC_G$	-0.03	—	0.12	%/°C	-25 °C to 100 °C [-13 °F to 212 °F]
<b>Rise time</b>	$t_r$	—	3	—	µs	0 A to 2.0 A

## BLOCK DIAGRAM

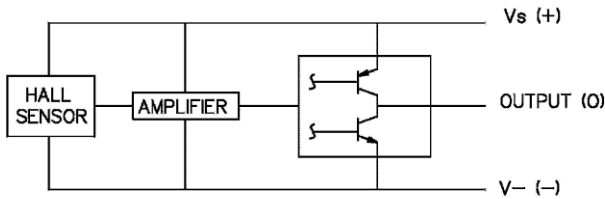

## CSLT6B100 TYPICAL TRANSFER FUNCTION [25 °C]

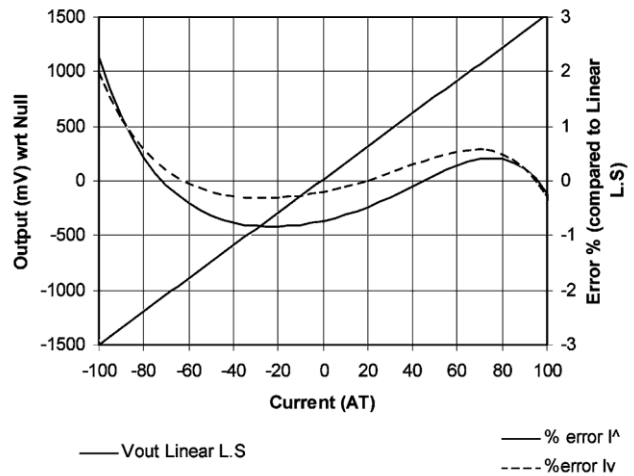

# Miniature, Open-Loop Current Sensors

DIMENSIONAL DRAWING (For reference only [mm])

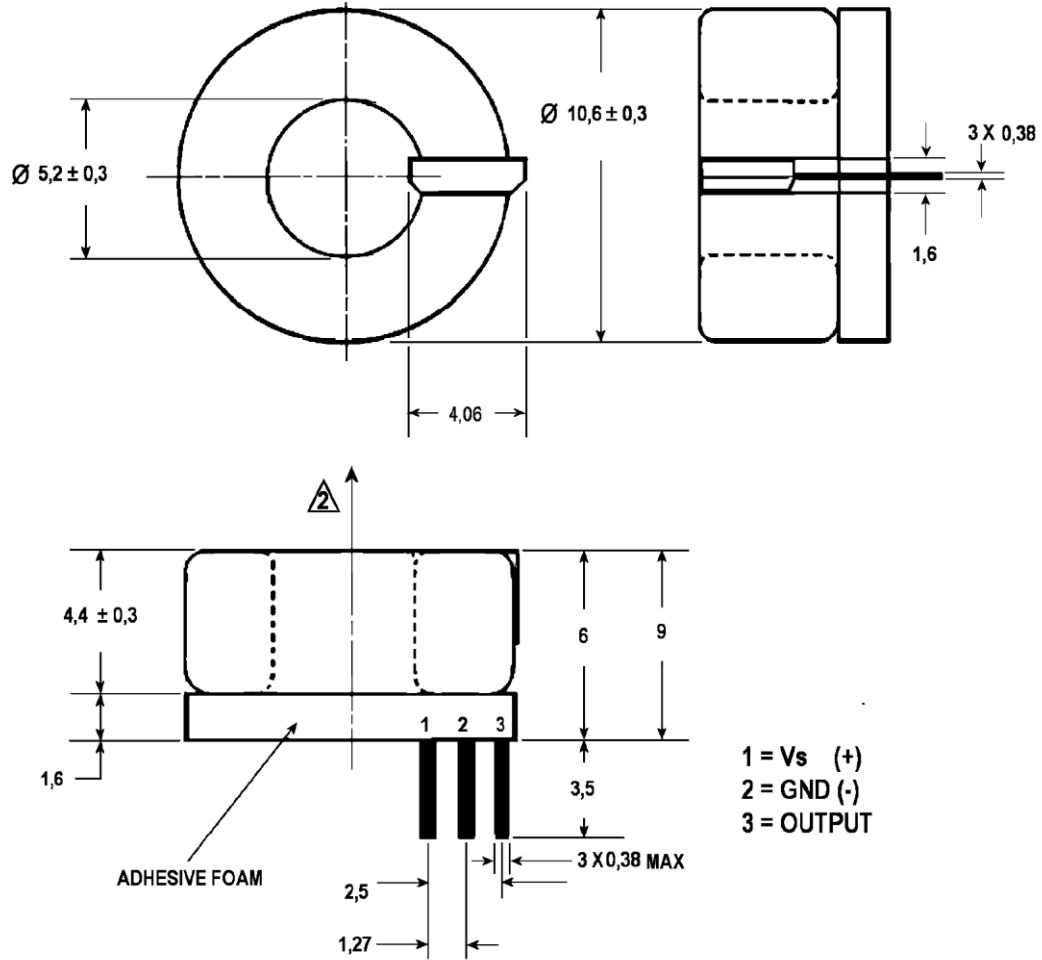

## ORDER GUIDE

Catalog Listing	Description
CSLT6B100	CSLT Series, Miniature, Open-Loop Current Sensor, 100 A

## **WARNING**

### **PERSONAL INJURY**

DO NOT USE these products as safety or emergency stop devices or in any other application where failure of the product could result in personal injury.

**Failure to comply with these instructions could result in death or serious injury.**

### **WARRANTY/REMEDY**

Honeywell warrants goods of its manufacture as being free of defective materials and faulty workmanship. Honeywell's standard product warranty applies unless agreed to otherwise by Honeywell in writing; please refer to your order acknowledgement or consult your local sales office for specific warranty details. If warranted goods are returned to Honeywell during the period of coverage, Honeywell will repair or replace, at its option, without charge those items it finds defective. **The foregoing is buyer's sole remedy and is in lieu of all other warranties, expressed or implied, including those of merchantability and fitness for a particular purpose. In no event shall Honeywell be liable for consequential, special, or indirect damages.**

While we provide application assistance personally, through our literature and the Honeywell web site, it is up to the customer to determine the suitability of the product in the application.

Specifications may change without notice. The information we supply is believed to be accurate and reliable as of this printing. However, we assume no responsibility for its use.

## **WARNING**

### **MISUSE OF DOCUMENTATION**

- The information presented in this product sheet is for reference only. Do not use this document as a product installation guide.
- Complete installation, operation, and maintenance information is provided in the instructions supplied with each product.

**Failure to comply with these instructions could result in death or serious injury.**

### **SALES AND SERVICE**

Honeywell serves its customers through a worldwide network of sales offices, representatives and distributors. For application assistance, current specifications, pricing or name of the nearest Authorized Distributor, contact your local sales office or:

**E-mail:** [info.sc@honeywell.com](mailto:info.sc@honeywell.com)

**Internet:** [www.honeywell.com/sensing](http://www.honeywell.com/sensing)

#### **Phone and Fax:**

Asia Pacific	+65 6355-2828
	+65 6445-3033 Fax
Europe	+44 (0) 1698 481481
	+44 (0) 1698 481676 Fax
Latin America	+1-305-805-8188
	+1-305-883-8257 Fax
USA/Canada	+1-800-537-6945
	+1-815-235-6847
	+1-815-235-6545 Fax

Sensing and Control  
Honeywell  
1985 Douglas Drive North  
Golden Valley, MN 55422  
[www.honeywell.com/sensing](http://www.honeywell.com/sensing)

005862-2-EN  
June 2012  
© 2012 Honeywell International Inc.

# **Honeywell**



Компания «ЭлектроПласт» предлагает заключение долгосрочных отношений при поставках импортных электронных компонентов на взаимовыгодных условиях!

Наши преимущества:

- Оперативные поставки широкого спектра электронных компонентов отечественного и импортного производства напрямую от производителей и с крупнейших мировых складов;
- Поставка более 17-ти миллионов наименований электронных компонентов;
- Поставка сложных, дефицитных, либо снятых с производства позиций;
- Оперативные сроки поставки под заказ (от 5 рабочих дней);
- Экспресс доставка в любую точку России;
- Техническая поддержка проекта, помощь в подборе аналогов, поставка прототипов;
- Система менеджмента качества сертифицирована по Международному стандарту ISO 9001;
- Лицензия ФСБ на осуществление работ с использованием сведений, составляющих государственную тайну;
- Поставка специализированных компонентов (Xilinx, Altera, Analog Devices, Intersil, Interpoint, Microsemi, Aeroflex, Peregrine, Syfer, Eurofarad, Texas Instrument, Miteq, Cobham, E2V, MA-COM, Hittite, Mini-Circuits, General Dynamics и др.);

Помимо этого, одним из направлений компании «ЭлектроПласт» является направление «Источники питания». Мы предлагаем Вам помощь Конструкторского отдела:

- Подбор оптимального решения, техническое обоснование при выборе компонента;
- Подбор аналогов;
- Консультации по применению компонента;
- Поставка образцов и прототипов;
- Техническая поддержка проекта;
- Защита от снятия компонента с производства.



#### Как с нами связаться

**Телефон:** 8 (812) 309 58 32 (многоканальный)

**Факс:** 8 (812) 320-02-42

**Электронная почта:** [org@eplast1.ru](mailto:org@eplast1.ru)

**Адрес:** 198099, г. Санкт-Петербург, ул. Калинина, дом 2, корпус 4, литера А.