

## Oven Temperature Sensor

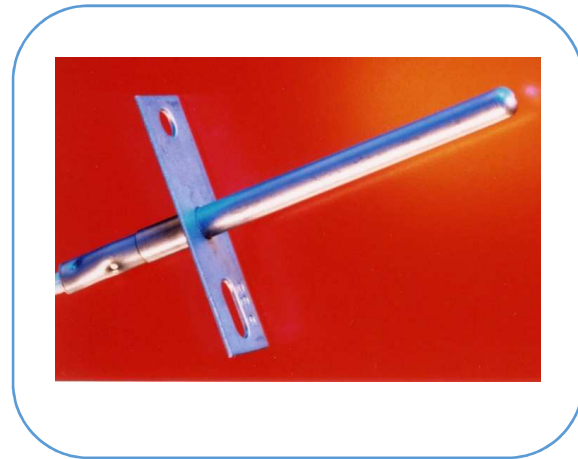

Platinum RTD sensor enclosed in closed-end stainless steel housing with integral mounting flange, fiberglass insulated lead wires.

### Applications

- Oven temperature
- Heating, ventilating, and air conditioning
- General purpose temperature sensing

### Features

- Flanged housing allows for easy mounting
- Standard design widely used in cooking ovens
- Available in Pt100 or Pt1000 resistance values
- Pt1000 available in TC3750 or TC3850
- +500°C maximum operating temperature

### Heraeus Sensor Technology

[www.heraeus-sensor-technology.com](http://www.heraeus-sensor-technology.com)

This data sheet does not constitute an offer or agreement to sell any product. Heraeus believes the information contained in this data sheet is accurate as of the version date. HOWEVER, NO REPRESENTATION OR WARRANTY OF ANY KIND, EXPRESS OR IMPLIED, IS MADE CONCERNING THE INFORMATION HEREIN PROVIDED OR THE PRODUCT TO WHICH THE INFORMATION REFERS. Heraeus does not accept legal responsibility for the use of this information. The information contained herein may not be valid for such product used in combination with any other materials, products, or in any process. It is the user's responsibility to satisfy itself that the product is suitable for the intended use.

Revision Date: 09/26

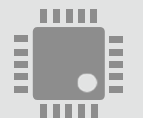

## Oven Temperature Sensor Specifications

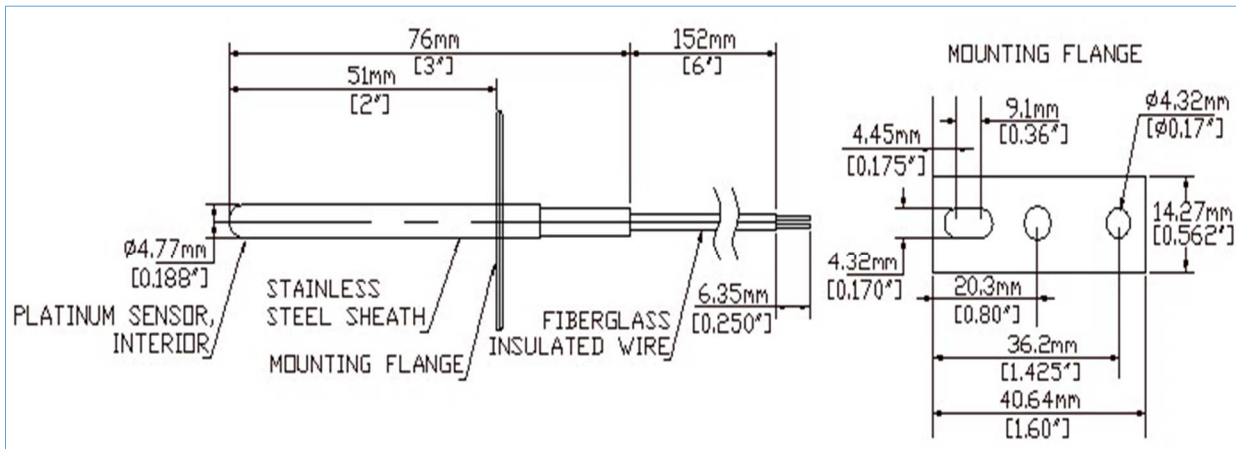

For 3 wire assemblies, one wire is marked to show polarity

Dimensions are in mm unless otherwise noted

### Specifications

#### Operating Temperature Range

-40°C to +500°C

#### Connection wire

Fiberglass-insulated, 2x0.22mm<sup>2</sup>  
(24AWG)

Pt100: 3 wire connection (one wire marked to indicate polarity)

Pt1000: 2 wire connection

#### Temperature sensing element

Platinum RTD, Pt100 or Pt1000, as per  
DIN EN 60751 F0.3

#### Housing

Stainless steel, 300 series

#### Wire resistance

0.030Ω/ft. (0.098Ω/m) for each conductor

### Heraeus Sensor Technology

[www.heraeus-sensor-technology.com](http://www.heraeus-sensor-technology.com)

This data sheet does not constitute an offer or agreement to sell any product. Heraeus believes the information contained in this data sheet is accurate as of the version date. HOWEVER, NO REPRESENTATION OR WARRANTY OF ANY KIND, EXPRESS OR IMPLIED, IS MADE CONCERNING THE INFORMATION HEREIN PROVIDED OR THE PRODUCT TO WHICH THE INFORMATION REFERS. Heraeus does not accept legal responsibility for the use of this information. The information contained herein may not be valid for such product used in combination with any other materials, products, or in any process. It is the user's responsibility to satisfy itself that the product is suitable for the intended use.

Revision Date: 09/26

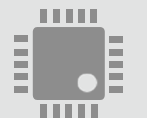

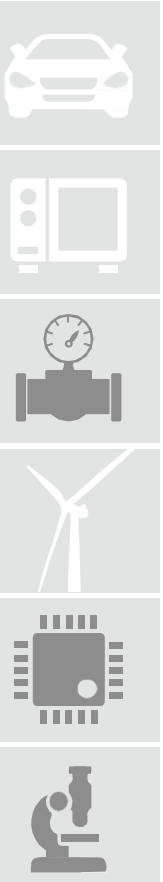

## Oven Temperature Sensor

### Options

Wire length

Resistance value

Connectors

### Ordering Code for Standard Product

Pt100 TC3850 (3 wire): 35110020

Pt1000 TC3850 (2 wire): 35110021

Pt1000 TC3750 (2 wire): 35110022

### Resistance vs Temperature Table

Reference tables @ [https://www.heraeus.com/en/hst/technical\\_information/technical\\_information\\_hst.aspx](https://www.heraeus.com/en/hst/technical_information/technical_information_hst.aspx)

### Contact Information

#### Heraeus Sensor Technology USA

770 Township Line Road, Suite 300 Yardley, PA 19067 USA

Phone: 1-215-944-9010 | Fax: 1-215-944-9392 | E-mail: [info.hst-us@heraeus.com](mailto:info.hst-us@heraeus.com) | Web: [www.heraeus-sensor-technology.com](http://www.heraeus-sensor-technology.com)

## Heraeus Sensor Technology

[www.heraeus-sensor-technology.com](http://www.heraeus-sensor-technology.com)

This data sheet does not constitute an offer or agreement to sell any product. Heraeus believes the information contained in this data sheet is accurate as of the version date. HOWEVER, NO REPRESENTATION OR WARRANTY OF ANY KIND, EXPRESS OR IMPLIED, IS MADE CONCERNING THE INFORMATION HEREIN PROVIDED OR THE PRODUCT TO WHICH THE INFORMATION REFERS. Heraeus does not accept legal responsibility for the use of this information. The information contained herein may not be valid for such product used in combination with any other materials, products, or in any process. It is the user's responsibility to satisfy itself that the product is suitable for the intended use.

Revision Date: 09/26



Компания «ЭлектроПласт» предлагает заключение долгосрочных отношений при поставках импортных электронных компонентов на взаимовыгодных условиях!

Наши преимущества:

- Оперативные поставки широкого спектра электронных компонентов отечественного и импортного производства напрямую от производителей и с крупнейших мировых складов;
- Поставка более 17-ти миллионов наименований электронных компонентов;
- Поставка сложных, дефицитных, либо снятых с производства позиций;
- Оперативные сроки поставки под заказ (от 5 рабочих дней);
- Экспресс доставка в любую точку России;
- Техническая поддержка проекта, помощь в подборе аналогов, поставка прототипов;
- Система менеджмента качества сертифицирована по Международному стандарту ISO 9001;
- Лицензия ФСБ на осуществление работ с использованием сведений, составляющих государственную тайну;
- Поставка специализированных компонентов (Xilinx, Altera, Analog Devices, Intersil, Interpoint, Microsemi, Aeroflex, Peregrine, Syfer, Eurofarad, Texas Instrument, Miteq, Cobham, E2V, MA-COM, Hittite, Mini-Circuits, General Dynamics и др.);

Помимо этого, одним из направлений компании «ЭлектроПласт» является направление «Источники питания». Мы предлагаем Вам помощь Конструкторского отдела:

- Подбор оптимального решения, техническое обоснование при выборе компонента;
- Подбор аналогов;
- Консультации по применению компонента;
- Поставка образцов и прототипов;
- Техническая поддержка проекта;
- Защита от снятия компонента с производства.



#### Как с нами связаться

**Телефон:** 8 (812) 309 58 32 (многоканальный)

**Факс:** 8 (812) 320-02-42

**Электронная почта:** [org@eplast1.ru](mailto:org@eplast1.ru)

**Адрес:** 198099, г. Санкт-Петербург, ул. Калинина, дом 2, корпус 4, литера А.