

600-V High- and Low-Side Driver with Bootstrap Diode

Features

- Floating channel designed for bootstrap operation
- Fully operational to +600 V
- Tolerant to negative transient voltage, dV/dt immune
- Gate drive supply range from 10 V to 20 V
- Under-voltage lockout for both channels
- 3.3 V, 5 V, and 15 V input logic compatible
- Matched propagation delay for both channels
- Lower di/dt gate driver for better noise immunity
- Outputs in phase with inputs
- Integrated bootstrap diode
- Suitable for both trapezoidal and sinusoidal motor control
- RoHS compliant

Product Summary

V_{OFFSET}	600 V
V_{OUT}	10 V – 20 V
$I_{\text{O+}} \& I_{\text{O-}}$ (typ.)	200 mA & 350 mA
$t_{\text{ON}} \& t_{\text{OFF}}$ (typ.)	515 ns & 500 ns
Delay matching (max.)	50 ns

Description

The IRS2817D and IRS2807D are high voltage, high speed power MOSFET and IGBT drivers with independent high and low side referenced output channels. Proprietary HVIC and latch immune CMOS technologies enable ruggedized monolithic construction. The logic input is compatible with standard CMOS or LSTTL output, down to 3.3 V logic. The output drivers feature a high-pulse current buffer stage designed for minimum driver cross-conduction. The floating channel can be used to drive N-channel power MOSFETs or IGBTs in the high side configuration which operates up to 600 V.

Package Options



Typical Applications

- Motor Control
- Air Conditioners
- Washing Machines
- General Purpose Inverters
- Micro/Mini Inverter Drives

Base Part Number	Package Type	Standard Pack		Orderable Part Number
		Form	Quantity	
IRS2807DS	8-Lead SOIC	Tube/Bulk	95	IRS2807DSPBF
		Tape and Reel	2500	IRS2807DSTRPBF
IRS2817DS	8-Lead SOIC	Tube/Bulk	95	IRS2817DSPBF
		Tape and Reel	2500	IRS2817DSTRPBF

Typical Connection Diagram

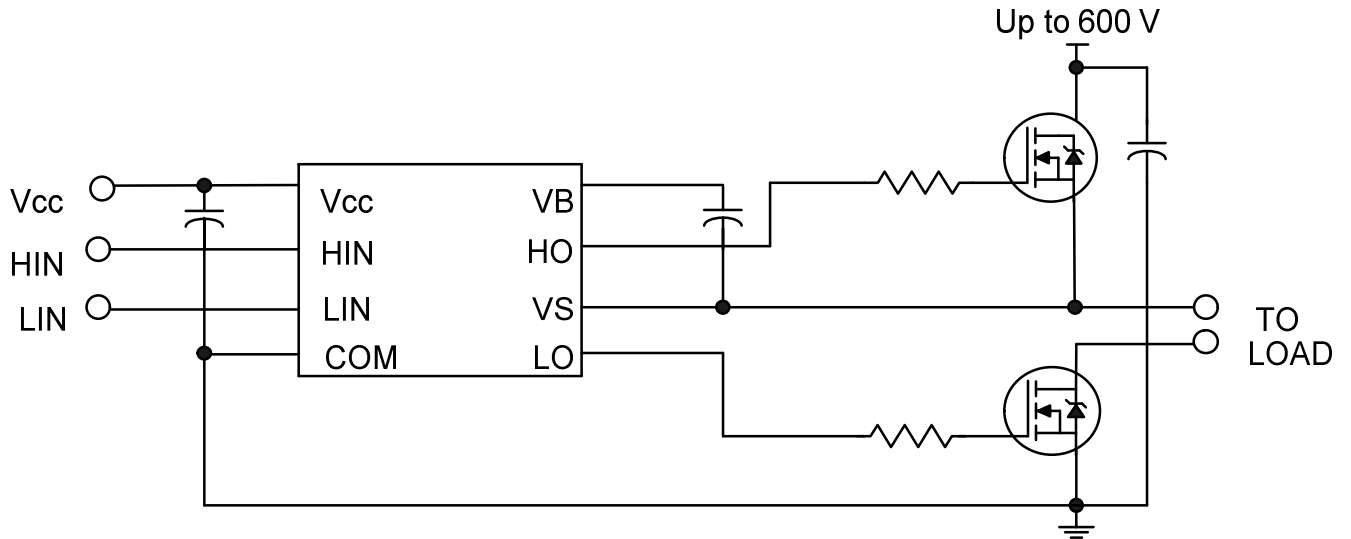

(Refer to Lead Assignments for correct pin configuration). This diagram shows electrical connections only. Please refer to our Application Notes & Design Tips for proper circuit board layout.

Absolute Maximum Ratings

Absolute Maximum Ratings indicate sustained limits beyond which damage to the device may occur. All voltage parameters are absolute voltages referenced to COM. The thermal resistance and power dissipation ratings are measured under board mounted and still air conditions.

Symbol	Definition	Min.	Max.	Units	
V_B	High side floating supply voltage	-0.3	625	V	
V_S	High side floating supply offset voltage	$V_B - 25^\dagger$	$V_B + 0.3$		
V_{HO}	High side floating output voltage	$V_S - 0.3$	$V_B + 0.3$		
V_{CC}	Low side and logic fixed supply voltage	-0.3	25		
V_{LO}	Low side output voltage	-0.3	$V_{CC} + 0.3$		
V_{IN}	Logic input voltage	COM -0.3	$V_{CC} + 0.3$		
dV_S/dt	Allowable offset supply voltage transient	—	50	V/ns	
P_D	Package power dissipation @ $T_A \leq +25^\circ\text{C}$	8-Lead SOIC	—	0.625	W
R_{thJA}	Thermal resistance, junction to ambient	8-Lead SOIC	—	200	$^\circ\text{C}/\text{W}$
T_J	Junction temperature	—	150	$^\circ\text{C}$	
T_S	Storage temperature	-50	150		
T_L	Lead temperature (soldering, 10 seconds)	—	300		

† Zener clamps are included between V_{CC} & COM, V_B & V_S (20 V).

Recommended Operating Conditions

For proper operation the device should be used within the recommended conditions. The V_S offset ratings are tested with all supplies biased at a 15 V differential.

Symbol	Definition	Min	Max	Units
V_B	High side floating supply absolute voltage	$V_S + 10$	$V_S + 20$	V
V_S	Static high side floating supply offset voltage	COM- 8 [†]	600	
V_{St}	Transient high side floating supply offset voltage	-50 ^{††}	600	
V_{HO}	High side floating output voltage	V_S	V_B	
V_{CC}	Low side and logic fixed supply voltage	10	20	
V_{LO}	Low side output voltage	0	V_{CC}	
V_{IN}	Logic input voltage	COM	V_{CC}	
T_A	Ambient temperature	-40	125	$^\circ\text{C}$

† Logic operational for V_S of -8 V to +600 V. Logic state held for V_S of -8 V to $-V_{BS}$

†† Operational for transient negative V_S of COM -50 V with a 50 ns pulse width. Guaranteed by design. Refer to the Application Information section for more details

Static Electrical Characteristics

$V_{CC} = V_{BS} = 15\text{ V}$ and $T_A = 25^\circ\text{C}$ unless otherwise specified. The V_{IL} , V_{IH} , and I_{IN} parameters are referenced to COM and are applicable to the respective input leads. The V_O , I_O , and R_{ON} parameters are referenced to COM and are applicable to the respective output leads: HO and LO.

Symbol	Definition	Min.	Typ.	Max.	Units	Test Conditions
V_{IH}	Logic "1" input voltage	2.2	—	—	V	$I_O = 20\text{ mA}$
V_{IL}	Logic "0" input voltage	—	—	0.8		
V_{OH}	High level output voltage	—	0.8	1.4		
V_{OL}	Low level output voltage	—	0.3	0.6		
I_{LK}	Offset supply leakage current	—	—	50	μA	$V_B = V_S = 600\text{ V}$
I_{QBS}	Quiescent V_{BS} supply current	—	45	70		$V_{IN} = 0\text{ V or }4\text{ V}$
I_{QCC}	Quiescent V_{CC} supply current (IRS2807DS)	1000	1700	3000		
	Quiescent V_{CC} supply current (IRS2817DS)	1000	1800	3000		
I_{IN+}	Logic "1" input bias current	—	5	20		$V_{IN} = 4\text{ V}$
I_{IN-}	Logic "0" input bias current	—	—	2	$V_{IN} = 0\text{ V}$	
V_{CCUV+} V_{BSUV+}	V_{CC} and V_{BS} supply under-voltage positive going threshold (IRS2807DS)	8.0	8.9	9.8	V	
	V_{CC} and V_{BS} supply under-voltage positive going threshold (IRS2817DS)	10.6	11.1	11.6		
V_{CCUV-} V_{BSUV-}	V_{CC} and V_{BS} supply under-voltage negative going threshold (IRS2807DS)	6.9	7.7	8.5		
	V_{CC} and V_{BS} supply under-voltage negative going threshold (IRS2817DS)	10.4	10.9	11.4		
V_{CCUVH} V_{BSUVH}	V_{CC} and V_{BS} supply under-voltage hysteresis (IRS2807DS)	—	1.2	—		
	V_{CC} and V_{BS} supply under-voltage hysteresis (IRS2817DS)	—	0.2	—		
I_{O+}	Output high short circuit pulsed current	120	200	—	mA	$V_O = 0\text{ V},$ $PW \leq 10\ \mu\text{s}$
I_{O-}	Output low short circuit pulsed current	250	350	—		$V_O = 15\text{ V},$ $PW \leq 10\ \mu\text{s}$
R_{BS}	Bootstrap resistance [†]	—	200	—	Ω	

† Please refer to the Application Section for the integrated bootstrap description.

Dynamic Electrical Characteristics

$V_{CC} = V_B = 15\text{ V}$, $T_A = 25^\circ\text{C}$, and $C_L = 1000\text{ pF}$.

Symbol	Definition	Min.	Typ.	Max.	Units	Test Conditions
t_{on}	Turn-on propagation delay	—	515	715	ns	$V_S = 0\text{ V or }600\text{ V}$
t_{off}	Turn-off propagation delay	—	500	700		
MT	Delay matching, HS & LS turn-on/off	—	—	50		$V_S = 0\text{ V}$
t_r	Turn-on rise time	—	150	220		
t_f	Turn-off fall time	—	50	80		
t_{fil}	Minimum pulse input filter time	—	300	—		

Functional Block Diagram

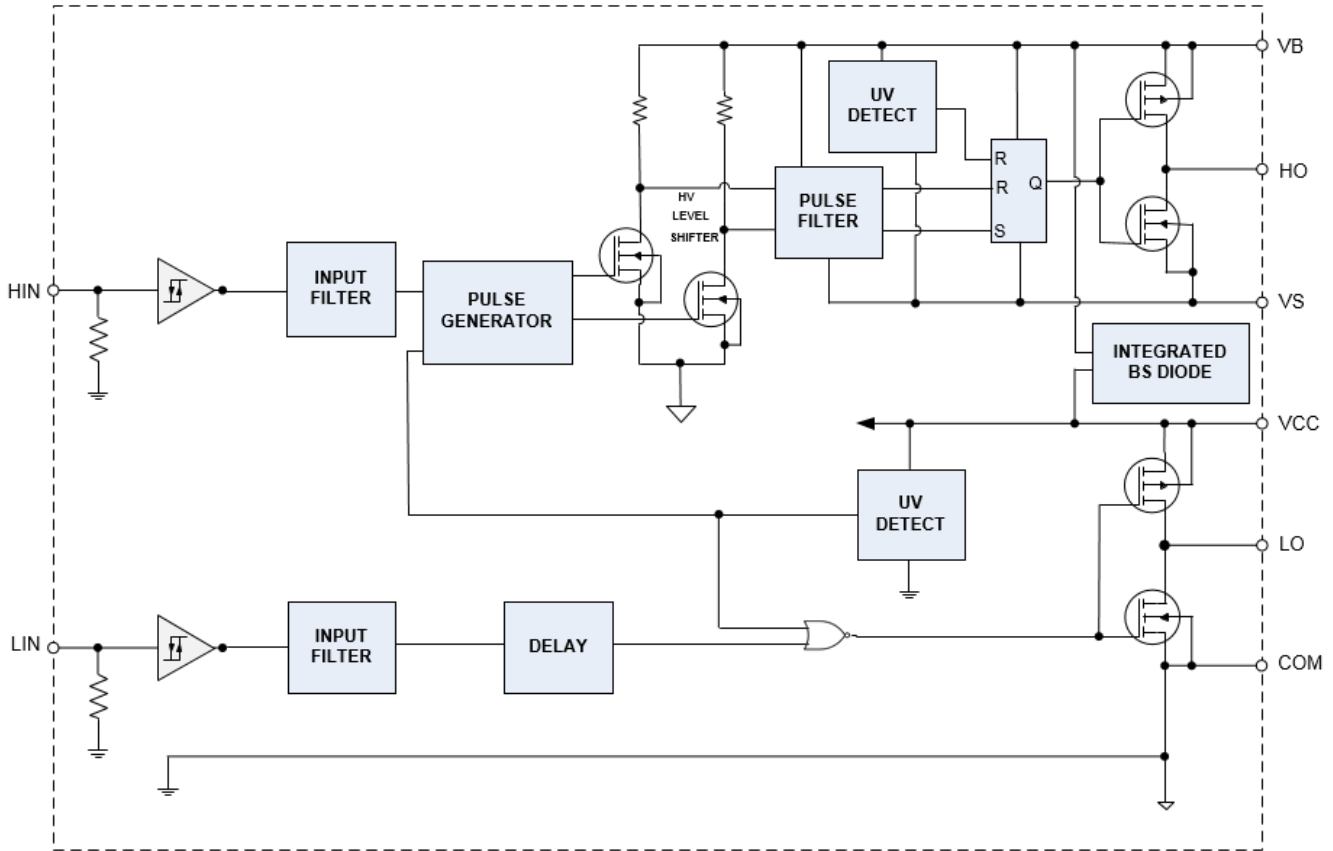

Lead Definitions

Symbol	Description
HIN	Logic input for high side gate driver output (HO), in phase
LIN	Logic input for low side gate driver output (LO), in phase
V_B	High side floating supply
HO	High side gate drive output
V_S	High side floating supply return
V_{CC}	Low side and logic fixed supply
LO	Low side gate drive output
COM	Low side return

Lead Assignments

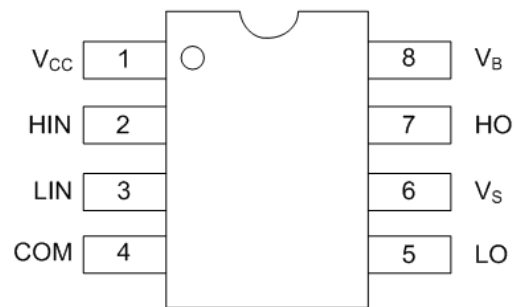

8-Lead SOIC

IRS28x7D

Application Information and Additional Details

Information regarding the following topics is included as subsections within this section of the datasheet.

- IGBT/MOSFET Gate Drive
- Switching and Timing Relationships
- Matched Propagation Delays
- Input Logic Compatibility
- Under-voltage Lockout Protection
- Advanced Input Filter
- Short-Pulse / Noise Rejection
- Integrated Bootstrap Functionality
- Negative VS Transient SOA
- PCB Layout Tips
- Integrated Bootstrap FET limitation
- Additional Documentation

IGBT/MOSFET Gate Drive

The IRS28x7D HVICs are designed to drive MOSFET or IGBT power devices. Figures 1 and 2 illustrate several parameters associated with the gate drive functionality of the HVIC. The output current of the HVIC, used to drive the gate of the power switch, is defined as I_O . The voltage that drives the gate of the external power switch is defined as V_{HO} for the high-side power switch and V_{LO} for the low-side power switch; this parameter is sometimes generically called V_{OUT} and in this case does not differentiate between the high-side or low-side output voltage.

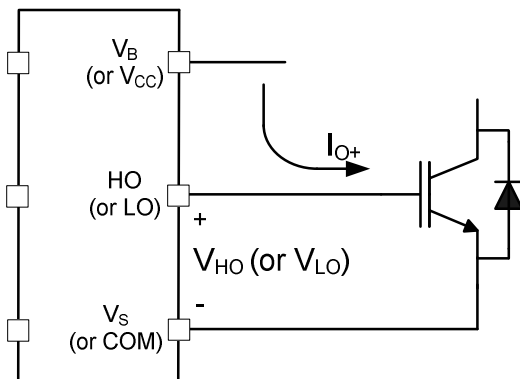

Figure 1. HVIC sourcing current

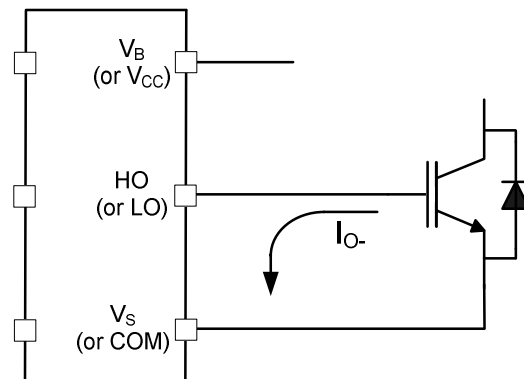

Figure 2. HVIC sinking current

Switching and Timing Relationships

The relationships between the input and output signals of the IRS28x7D are illustrated below in Figures 3, 4. From these figures, we can see the definitions of several timing parameters (i.e., PW_{IN} , PW_{OUT} , t_{ON} , t_{OFF} , t_r , and t_f) associated with this device.

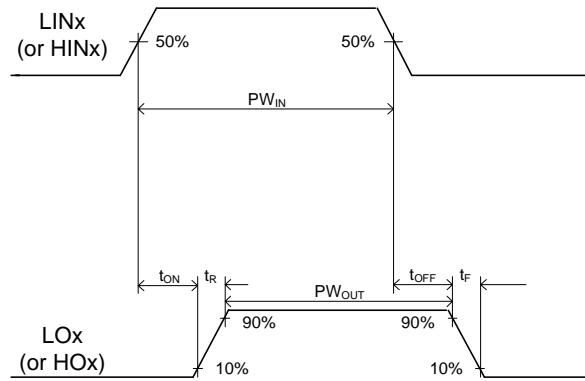

Figure 3: Switching time waveforms

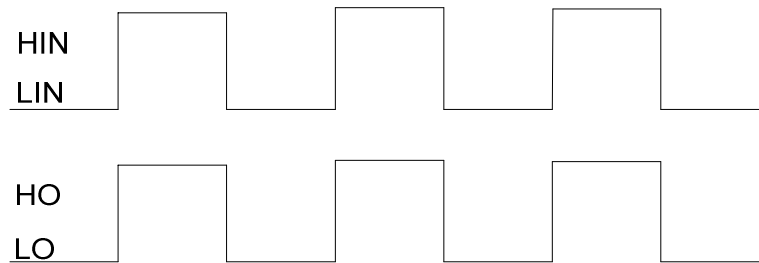

Figure 4. Input/output timing diagram

Matched Propagation Delays

The IRS28x7D HVICs are designed with propagation delay matching circuitry. With this feature, the IC's response at the output to a signal at the input requires approximately the same time duration (i.e., t_{ON} , t_{OFF}) for both the low-side channels and the high-side channels; the maximum difference is specified by the delay matching parameter (MT). The propagation turn-on delay (t_{ON}) of the IRS28x7D is matched to the propagation turn-on delay (t_{OFF}).

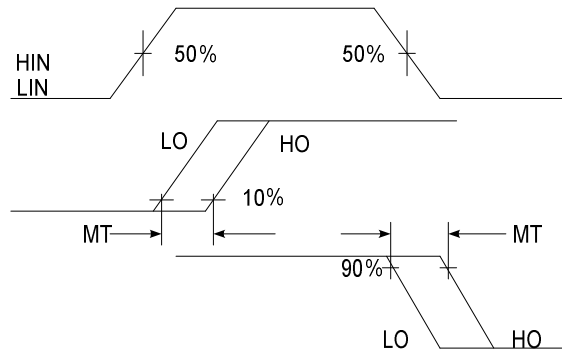

Figure 5. Delay Matching Waveform Definition

Input Logic Compatibility

The inputs of this IC are compatible with standard CMOS and TTL outputs. The IRS28x7D have been designed to be compatible with 3.3 V and 5 V logic-level signals. Figure 8 illustrates an input signal to the IRS28x7D, its input threshold values, and the logic state of the IC as a result of the input signal.

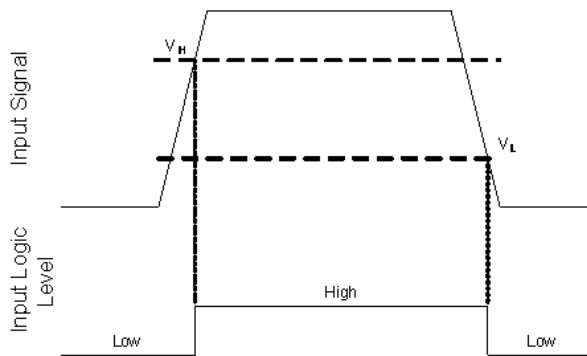

Figure 6. HIN & LIN input thresholds

Under-voltage Lockout Protection

This IC provides under-voltage lockout protection on both the V_{CC} (logic and low-side circuitry) power supply and the V_{BS} (high-side circuitry) power supply. Figure 7 is used to illustrate this concept; V_{CC} (or V_{BS}) is plotted over time and as the waveform crosses the UVLO threshold ($V_{CCUV+/-}$ or $V_{BSUV+/-}$) the under-voltage protection is enabled or disabled.

Upon power-up, should the V_{CC} voltage fail to reach the V_{CCUV+} threshold, the IC will not turn-on. Additionally, if the V_{CC} voltage decreases below the V_{CCUV-} threshold during operation, the under-voltage lockout circuitry will recognize a fault condition and shutdown the high and low-side gate drive outputs.

Upon power-up, should the V_{BS} voltage fail to reach the V_{BSUV} threshold, the IC will not turn-on. Additionally, if the V_{BS} voltage decreases below the V_{BSUV} threshold during operation, the under-voltage lockout circuitry will recognize a fault condition, and shutdown the high-side gate drive outputs of the IC.

The UVLO protection ensures that the IC drives the external power devices only when the gate supply voltage is sufficient to fully enhance the power devices. Without this feature, the gates of the external power switch could be driven with a low voltage, resulting in the power switch conducting current while the channel impedance is high; this could result in very high conduction losses within the power device and could lead to power device failure.

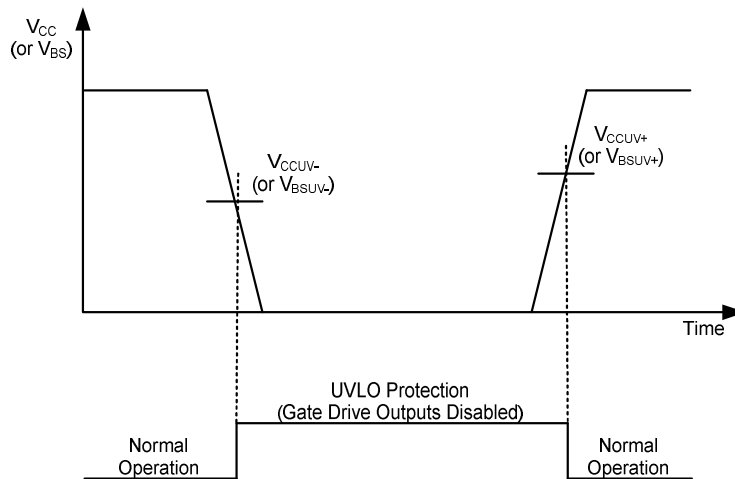

Figure 7. UVLO protection

Advanced Input Filter

The advanced input filter allows an improvement in the input/output pulse symmetry of the HVIC and helps to reject noise spikes and short pulses. This input filter has been applied to the HIN and LIN inputs. The working principle of the new filter is shown in Figures 8 and 9.

Figure 8 shows a typical input filter and the asymmetry of the input and output. The upper pair of waveforms (Example 1) show an input signal with a duration much longer than $t_{FIL,IN}$; the resulting output is approximately the difference between the input signal and $t_{FIL,IN}$. The lower pair of waveforms (Example 2) show an input signal with a duration slightly longer than $t_{FIL,IN}$; the resulting output is approximately the difference between the input signal and $t_{FIL,IN}$.

Figure 9 shows the advanced input filter and the symmetry between the input and output. The upper pair of waveforms (Example 1) show an input signal with a duration much longer than $t_{FIL,IN}$; the resulting output is approximately the same duration as the input signal. The lower pair of waveforms (Example 2) show an input signal with a duration slightly longer than $t_{FIL,IN}$; the resulting output is approximately the same duration as the input signal.

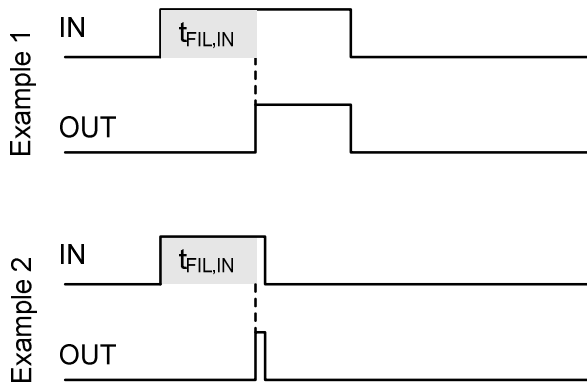

Figure 8. Typical input filter

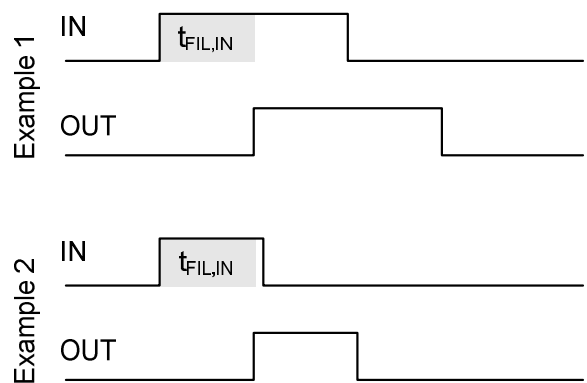

Figure 9. Advanced input filter

Short-Pulse / Noise Rejection

This device's input filter provides protection against short-pulses (e.g., noise) on the input lines. If the duration of the input signal is less than $t_{FIL,IN}$, the output will not change states. Example 1 of Figure 10 shows the input and output in the low state with positive noise spikes of durations less than $t_{FIL,IN}$; the output does not change states. Example 2 of Figure 10 shows the input and output in the high state with negative noise spikes of durations less than $t_{FIL,IN}$; the output does not change states.

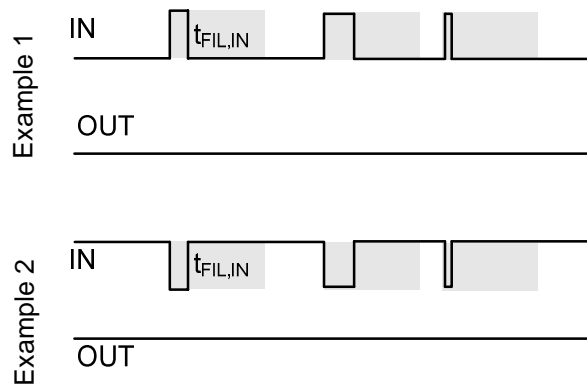

Figure 10. Noise rejecting input filters

Figures 11 and 12 present lab data that illustrates the characteristics of the input filters while receiving ON and OFF pulses.

The input filter characteristic is shown in Figure 11; the left side illustrates the narrow pulse ON (short positive pulse) characteristic while the left shows the narrow pulse OFF (short negative pulse) characteristic. The x-axis of Figure 11 shows the duration of PW_{IN} , while the y-axis shows the resulting PW_{OUT} duration. It can be seen that for a PW_{IN} duration less than $t_{FIL,IN}$, that the resulting PW_{OUT} duration is zero (e.g., the filter rejects the input signal/noise). We also see that once the PW_{IN} duration exceed $t_{FIL,IN}$, that the PW_{OUT} durations mimic the PW_{IN} durations very well over this interval with the symmetry improving as the duration increases. To ensure proper operation of the HVIC, it is suggested that the input pulse width for the high-side inputs be ≥ 500 ns.

The difference between the PW_{OUT} and PW_{IN} signals of both the narrow ON and narrow OFF cases is shown in Figure 12; the careful reader will note the scale of the y-axis. The x-axis of Figure 12 shows the duration of PW_{IN} , while the y-axis shows the resulting $PW_{OUT} - PW_{IN}$ duration. This data illustrates the performance and near symmetry of this input filter.

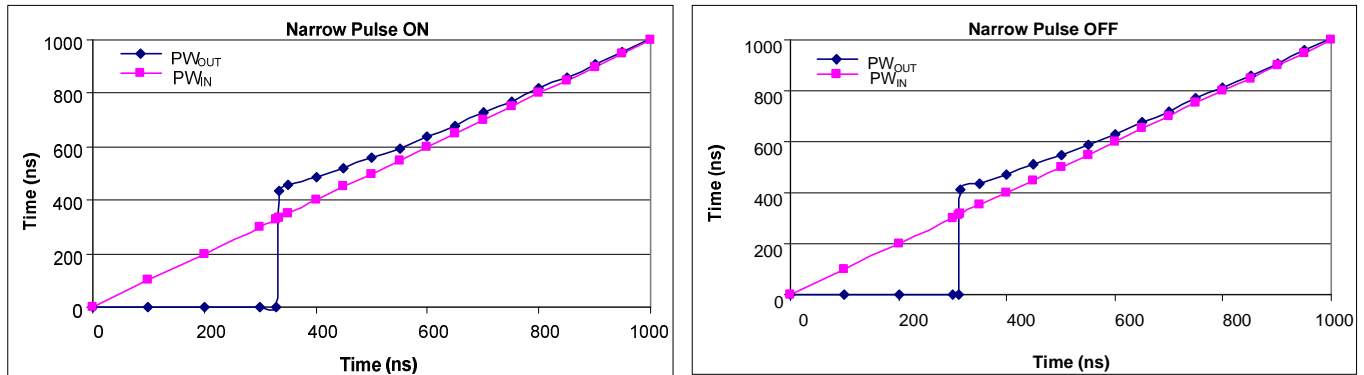

Figure 11. Input filter characteristic

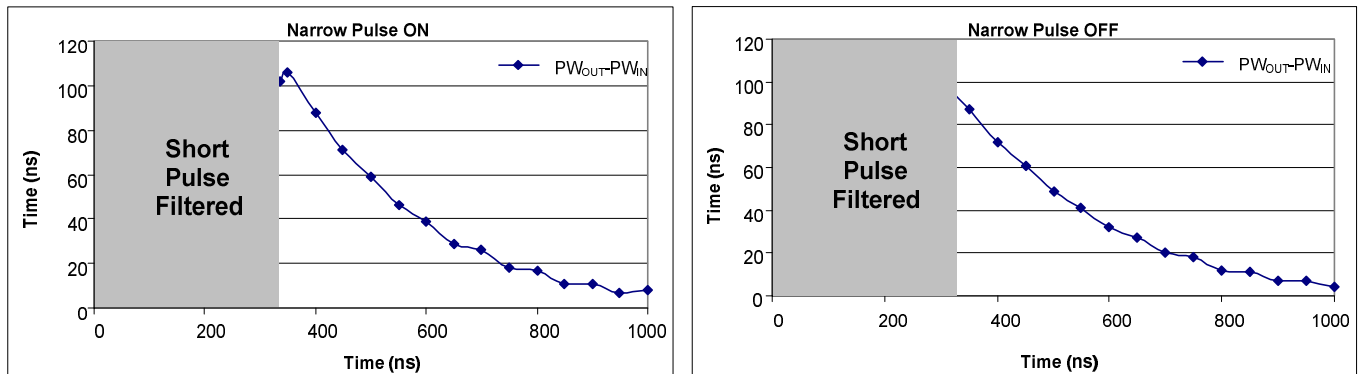

Figure 12. Difference between the input pulse and the output pulse

Integrated Bootstrap Functionality

The IRS28x7D embeds an integrated bootstrap FET that allows an alternative drive of the bootstrap supply for a wide range of applications.

A bootstrap FET is connected between the floating supply V_B and V_{CC} (see Fig. 13).

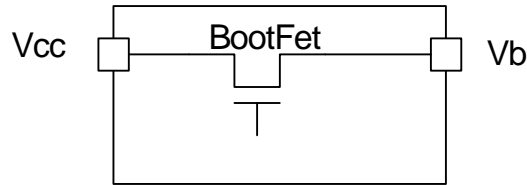

Figure 13. Simplified BootFET connection

The bootstrap FET is suitable for most PWM modulation schemes, including trapezoidal control, and can be used either in parallel with the external bootstrap network (diode+ resistor) or as a replacement of it. The use of the integrated bootstrap as a replacement of the external bootstrap network may have some limitations at a very high PWM duty cycle due to the bootstrap FET equivalent resistance (R_{BS} , see page 5).

The integrated bootstrap FET is turned on during the time when LO is 'high', and it has a limited source current due to R_{BS} . The V_{BS} voltage will be charged each cycle depending on the on-time of LO and the value of the C_{BS} capacitor, the drain-source (collector-emitter) drop of the external IGBT (or MOSFET), and the low-side free-wheeling diode drop.

The bootstrap FET follows the state of low-side output stage (i.e., the bootstrap FET is ON when LO is high, unless the V_B voltage is higher than approximately V_{CC} . In that case, the bootstrap FET is designed to remain off until V_B returns below that threshold; this concept is illustrated in Figure 14.

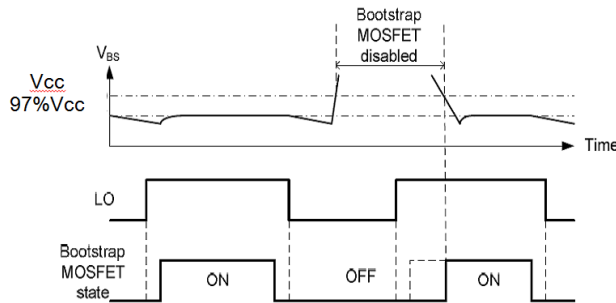

Figure 14. BootFET timing diagram

Tolerant to Negative V_s Transients

A common problem in today's high-power switching converters is the transient response of the switch node's voltage as the power switches transition on and off quickly while carrying a large current. A typical 3-phase inverter circuit is shown in Figure 15; here we define the power switches and diodes of the inverter.

If the high-side switch (e.g., the IGBT Q1 in Figures 16 and 17) switches off, while the U phase current is flowing to an inductive load, a current commutation occurs from high-side switch (Q1) to the diode (D2) in parallel with the low-side switch of the same inverter leg. At the same instance, the voltage node V_{s1} , swings from the positive DC bus voltage to the negative DC bus voltage.

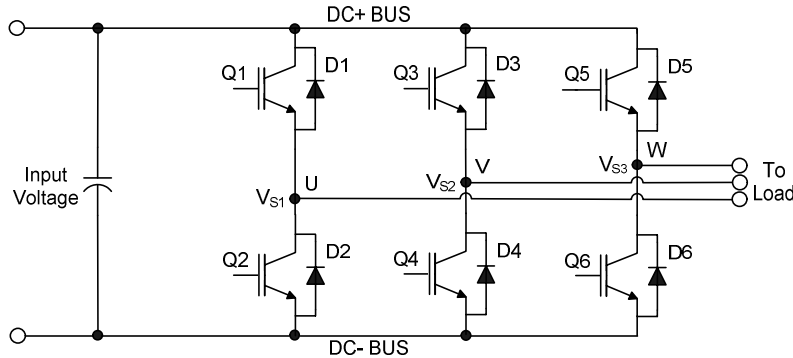

Figure 15. Three phase inverter

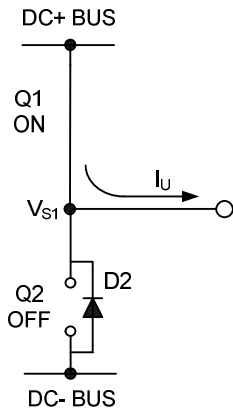

Figure 16. Q1 conducting

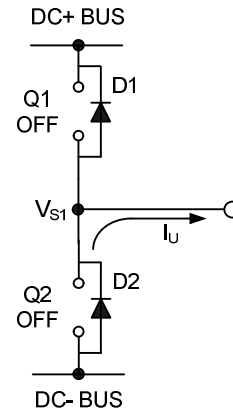
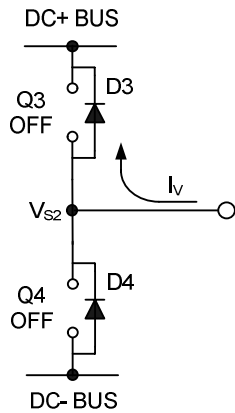
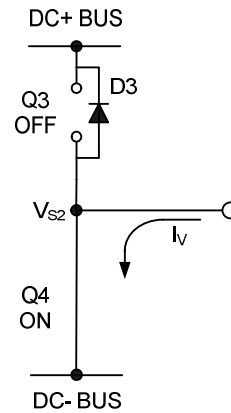

Figure 17. D2 conducting

Also when the V phase current flows from the inductive load back to the inverter (see Figures 18 and 19), and Q4 IGBT switches on, the current commutation occurs from D3 to Q4. At the same instance, the voltage node, V_{s2} , swings from the positive DC bus voltage to the negative DC bus voltage.

Figure 18. D3 conducting

Figure 19. Q4 conducting

However, in a real inverter circuit, the V_S voltage swing does not stop at the level of the negative DC bus, rather it swings below the level of the negative DC bus. This undershoot voltage is called “negative V_S transient”.

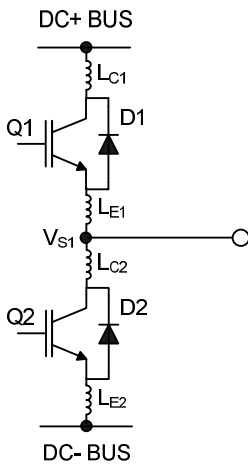
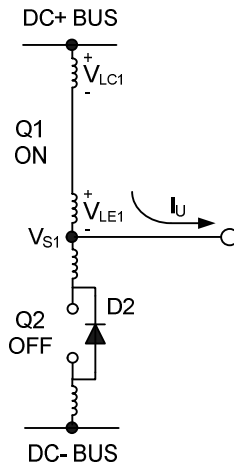
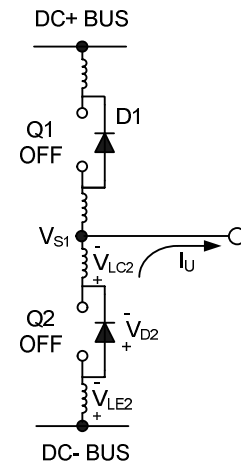
The circuit shown in Figure 20 depicts one leg of the three phase inverter; Figures 21 and 22 show a simplified illustration of the commutation of the current between Q1 and D2. The parasitic inductances in the power circuit from the die bonding to the PCB tracks are lumped together in L_C and L_E for each IGBT. When the high-side switch is on, V_{S1} is below the DC+ voltage by the voltage drops associated with the power switch and the parasitic elements of the circuit. When the high-side power switch turns off, the load current momentarily flows in the low-side freewheeling diode due to the inductive load connected to V_{S1} (the load is not shown in these figures). This current flows from the DC- bus (which is connected to the COM pin of the HVIC) to the load and a negative voltage between V_{S1} and the DC- Bus is induced (i.e., the COM pin of the HVIC is at a higher potential than the V_S pin).

Figure 20. Parasitic Elements

Figure 21. V_S positive

Figure 22. V_S negative

In a typical motor drive system, dV/dt is typically designed to be in the range of 3-5 V/ns. The negative V_S transient voltage can exceed this range during some events such as short circuit and over-current shutdown, when di/dt is greater than in normal operation.

International Rectifier’s HVICs have been designed for the robustness required in many of today’s demanding applications. An indication of the IRS28x7D’s robustness can be seen in Figure 23, where there is represented the IRS28x7D Safe Operating Area at $V_{BS}=15$ V based on repetitive negative V_S spikes. A negative V_S transient voltage falling in the grey area (outside SOA) may lead to IC permanent damage; vice versa unwanted functional anomalies or permanent damage to the IC do not appear if negative V_S transients fall inside SOA.

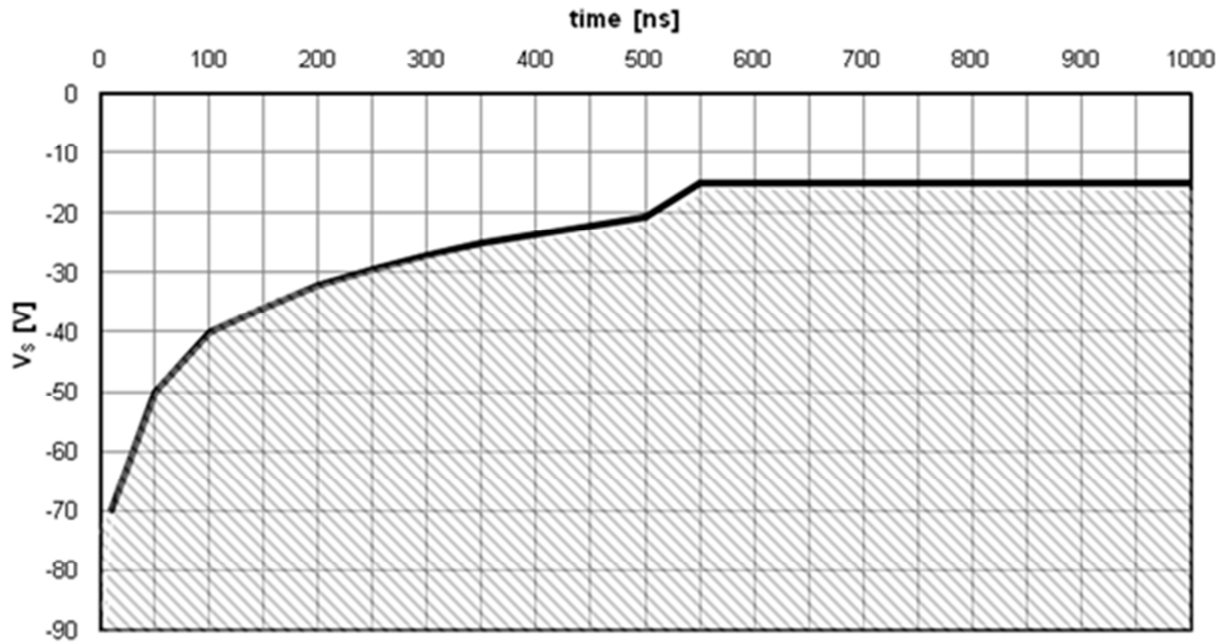

Figure 23. Negative V_s transient SOA for IRS28x7D @ V_{BS}=15 V

Even though the IRS28x7D has been shown able to handle these large negative V_s transient conditions, it is highly recommended that the circuit designer always limit the negative V_s transients as much as possible by careful PCB layout and component use.

PCB Layout Tips

Distance between high and low voltage components: It's strongly recommended to place the components tied to the floating voltage pins (V_B and V_S) near the respective high voltage portions of the device. Please see the Case Outline information in this datasheet for the details.

Ground Plane: In order to minimize noise coupling, the ground plane should not be placed under or near the high voltage floating side.

Gate Drive Loops: Current loops behave like antennas and are able to receive and transmit EM noise (see Figure 24). In order to reduce the EM coupling and improve the power switch turn on/off performance, the gate drive loops must be reduced as much as possible. Moreover, current can be injected inside the gate drive loop via the IGBT collector-to-gate parasitic capacitance. The parasitic auto-inductance of the gate loop contributes to developing a voltage across the gate-emitter, thus increasing the possibility of a self turn-on effect.

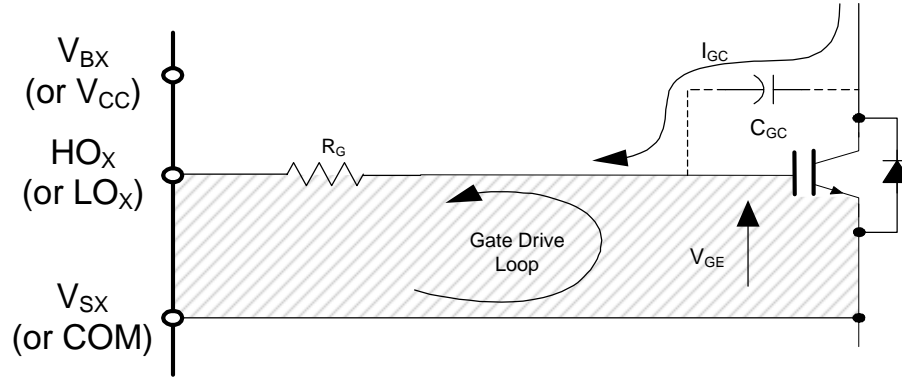

Figure 24. Antenna Loops

Supply Capacitor: It is recommended to place a bypass capacitor (C_{IN}) between the V_{CC} and COM pins. A ceramic $1\mu F$ ceramic capacitor is suitable for most applications. This component should be placed as close as possible to the pins in order to reduce parasitic elements.

Routing and Placement: Power stage PCB parasitic elements can contribute to large negative voltage transients at the switch node; it is recommended to limit the phase voltage negative transients. In order to avoid such conditions, it is recommended to 1) minimize the high-side emitter to low-side collector distance, and 2) minimize the low-side emitter to negative bus rail stray inductance. However, where negative V_S spikes remain excessive, further steps may be taken to reduce the spike. This includes placing a resistor ($5\ \Omega$ or less) between the V_S pin and the switch node (see Figure 25), and in some cases using a clamping diode between COM and V_S (see Figure 26). See DT04-4 at www.infineon.com for more detailed information.

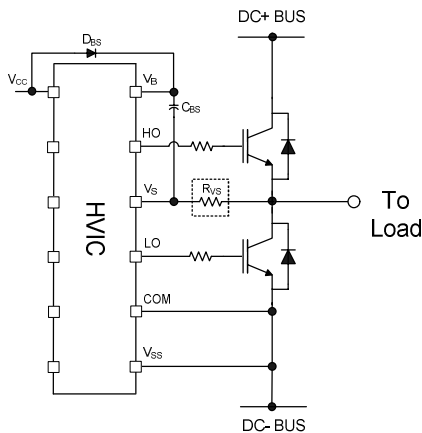

Figure 25. V_S resistor

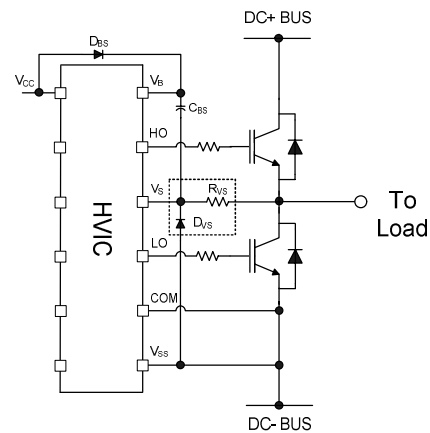

Figure 26. V_S clamping diode

Additional Documentation

Several technical documents related to the use of HVICs are available at www.infineon.com; use the Site Search function and the document number to quickly locate them. Below is a short list of some of these documents.

- DT97-3: Managing Transients in Control IC Driven Power Stages
- AN-1123: Bootstrap Network Analysis: Focusing on the Integrated Bootstrap Functionality
- DT04-4: Using Monolithic High Voltage Gate Drivers
- AN-978: HV Floating MOS-Gate Driver ICs

Parameters trend in temperature

Figures 27-48 provide information on the experimental performance of the IRS28x7D HVIC. The line plotted in each figure is generated from actual lab data. A large number of individual samples from multiple wafer lots were tested at three temperatures (-40°C, 25°C, and 125°C) in order to generate the experimental (Exp.) curve. The line labeled Exp. consist of three data points (one data point at each of the tested temperatures) that have been connected together to illustrate the understood trend. The individual data points on the curve were determined by calculating the averaged experimental value of the parameter (for a given temperature).

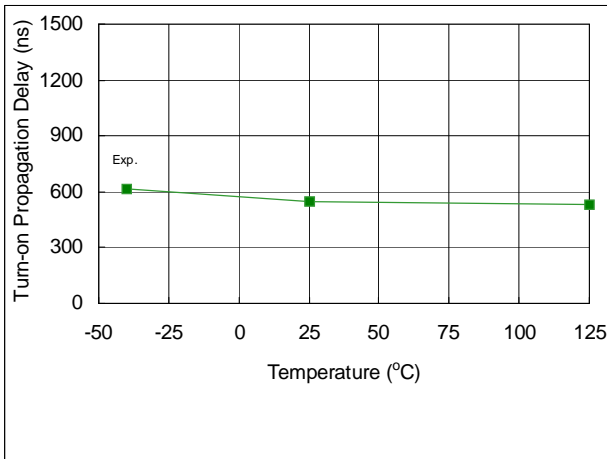

Figure 27. Turn-on Propagation Delay vs. Temperature

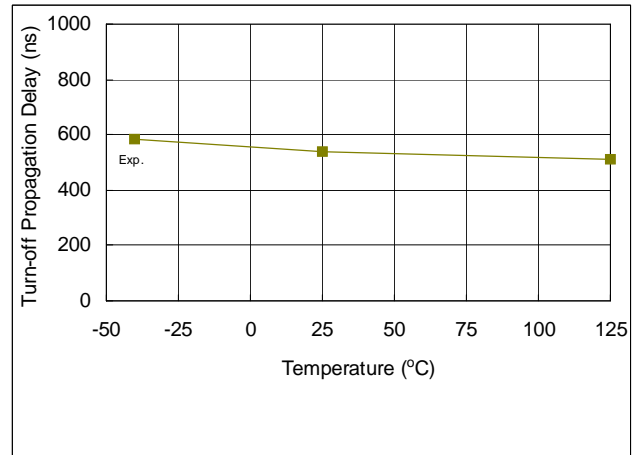

Figure 28. Turn-off Propagation Delay vs. Temperature

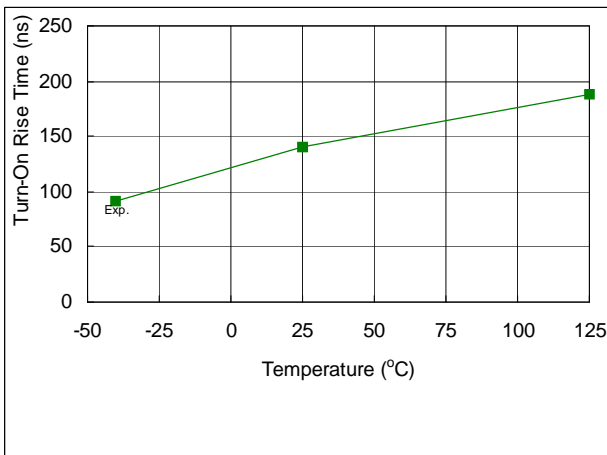

Figure 29. Turn-on Rise Time vs. Temperature

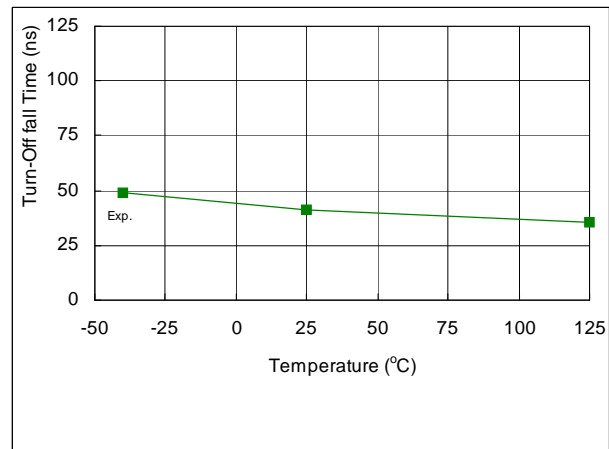

Figure 30. Turn-off Rise Time vs. Temperature

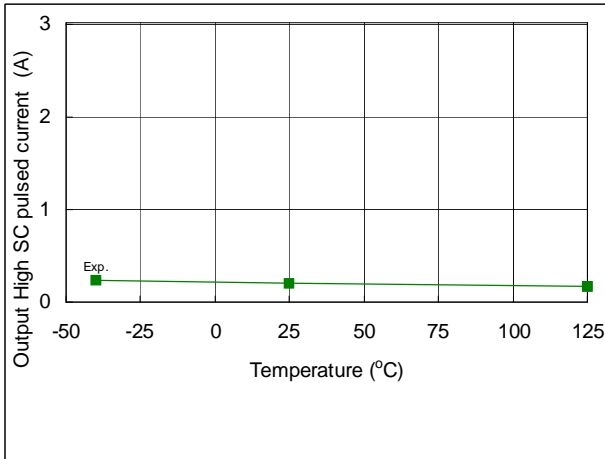

Figure 31. Output High SC Pulsed Current vs. Temperature

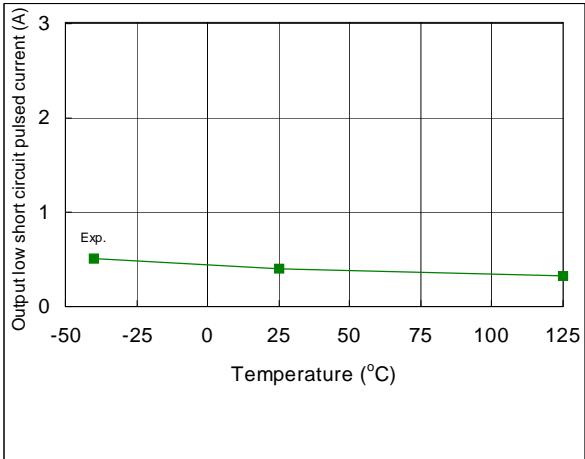

Figure 32. Output Low Short Circuit Pulsed Current vs. Temperature

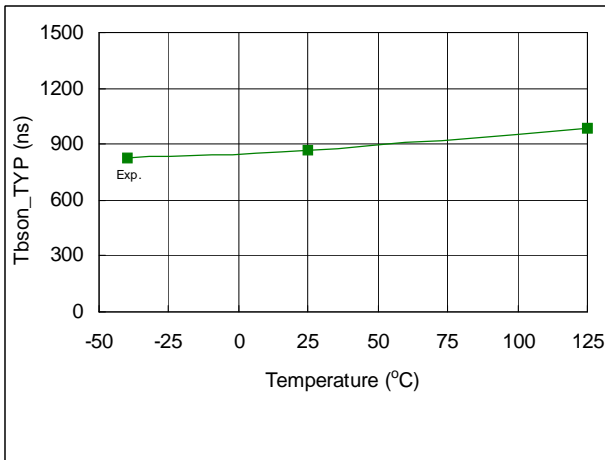

Figure 33. Tbson_TYP vs. Temperature

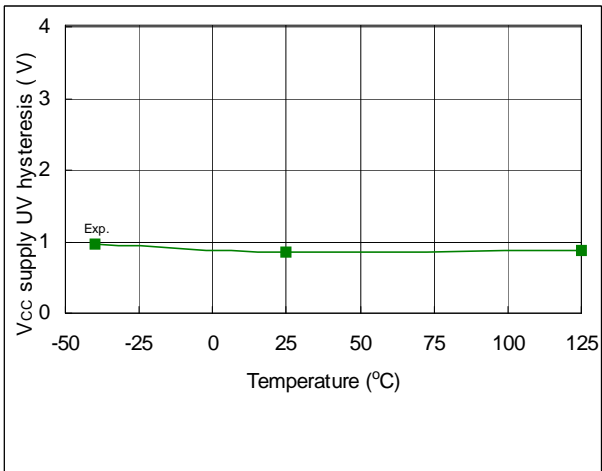

Figure 34. V_{CC} Supply UV Hysteresis vs. Temperature

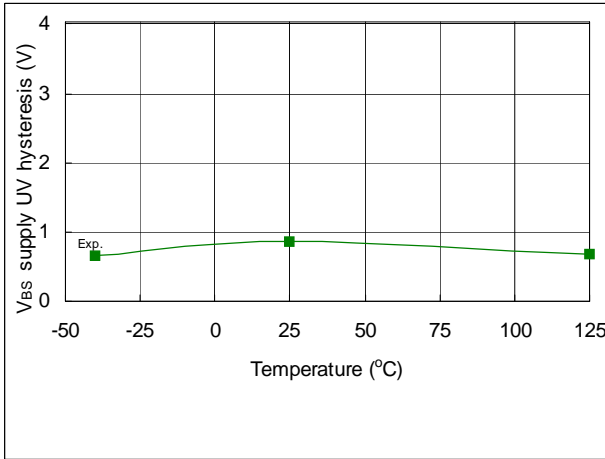

Figure 35. V_{BS} Supply UV Hysteresis vs. Temperature

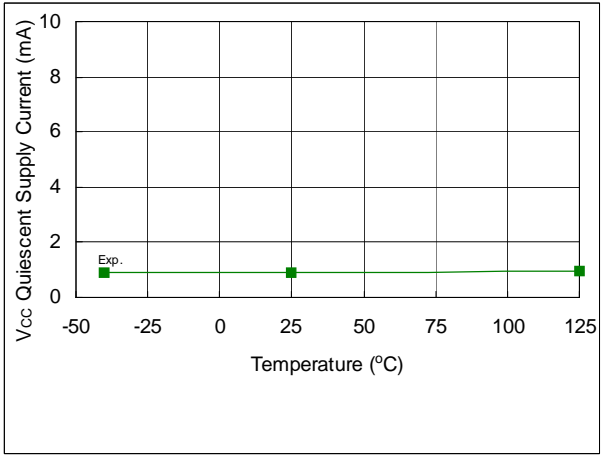

Figure 36. V_{CC} Quiescent Supply Current vs. Temperature

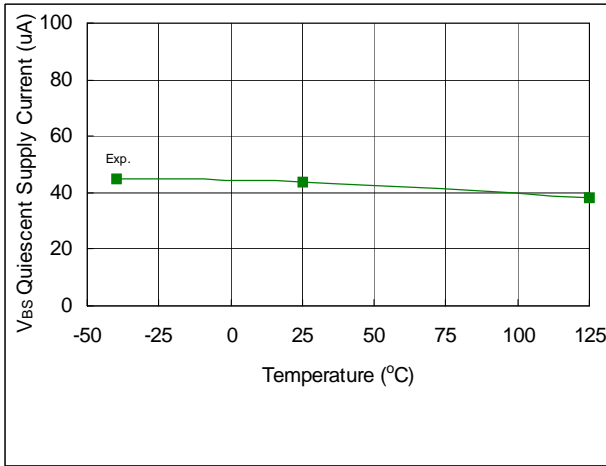

Figure 37. V_{BS} Quiescent Supply Current vs. Temperature

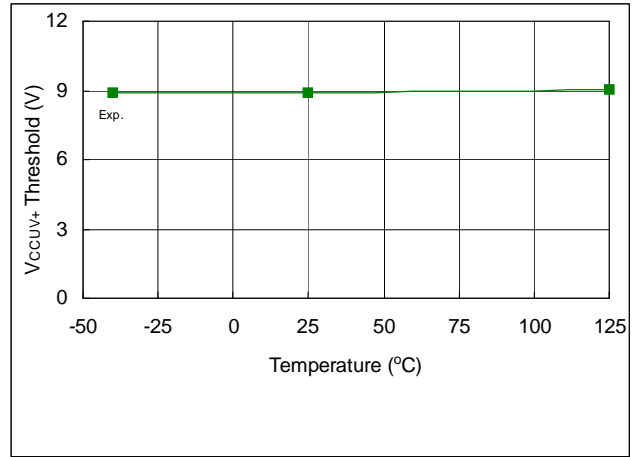

Figure 38. V_{CCUV+} Threshold vs. Temperature

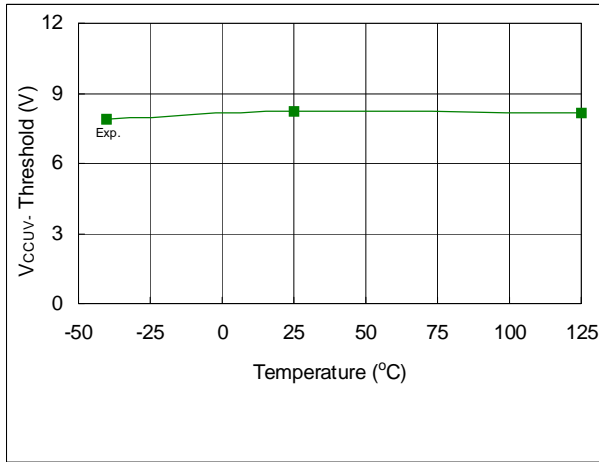

Figure 39. V_{CCUV-} Threshold vs. Temperature

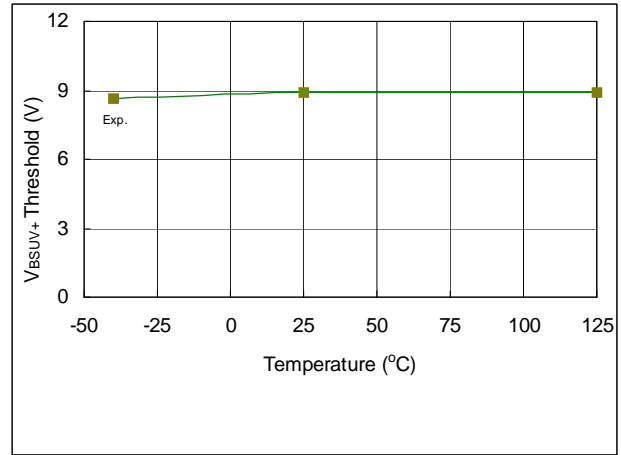

Figure 40. V_{BSUV+} Threshold vs. Temperature

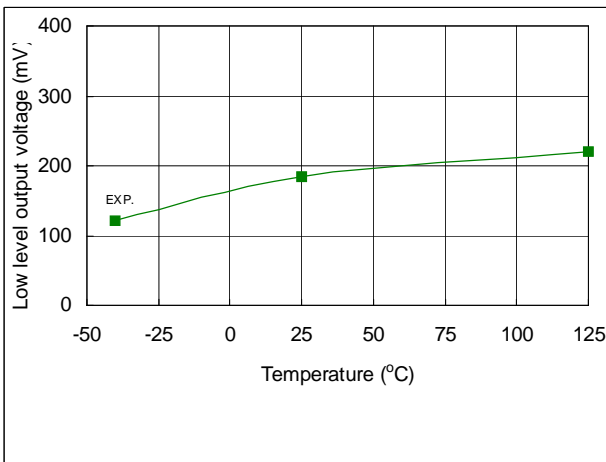

Figure 41. Low Level Output Voltage vs. Temperature

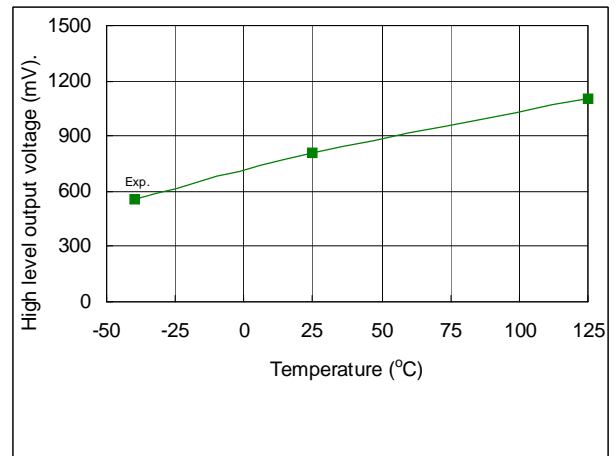

Figure 42. High Level Output Voltage vs. Temperature

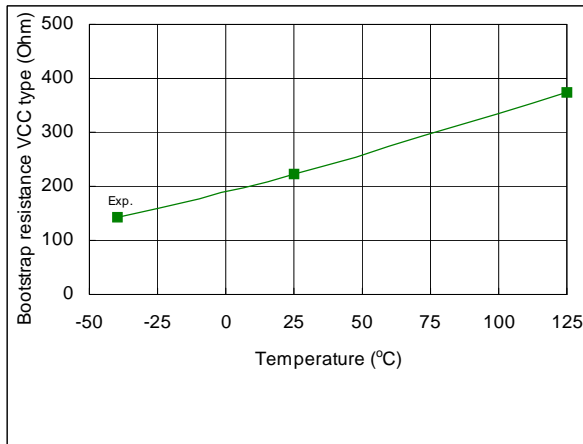

Figure 43. Bootstrap Resistance VCC type vs. Temperature

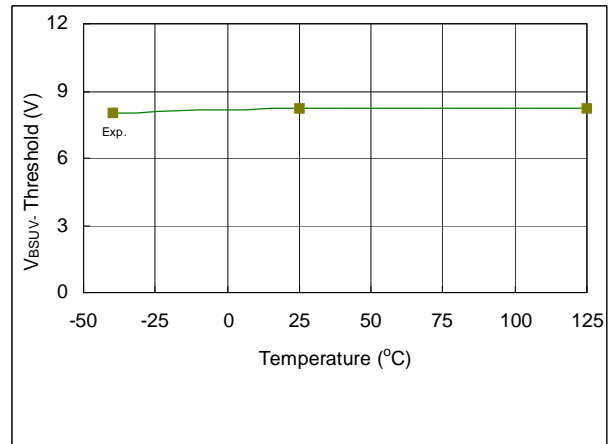

Figure 44. V_{BSUV-} Threshold vs. Temperature

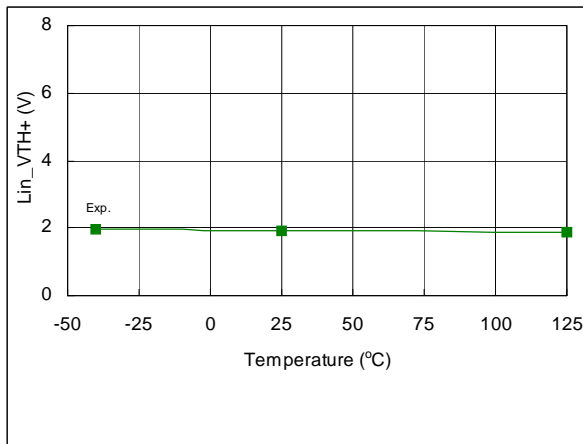

Figure 45. Lin_VTH+ vs. Temperature

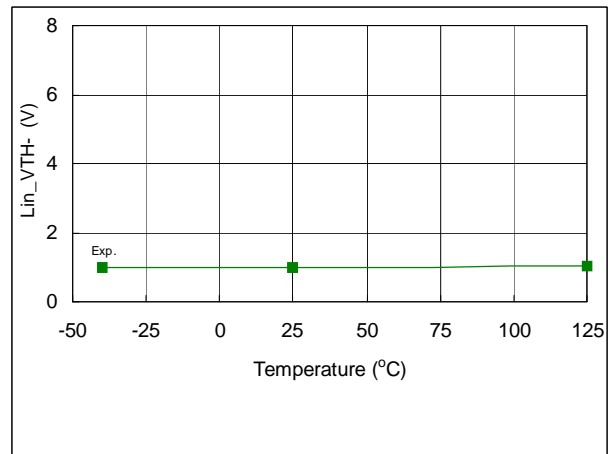

Figure 46. Lin_VTH- vs. Temperature

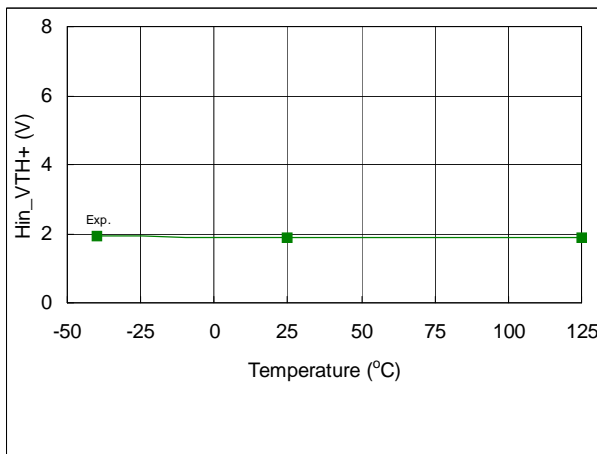

Figure 47. Hin_VTH+ vs. Temperature

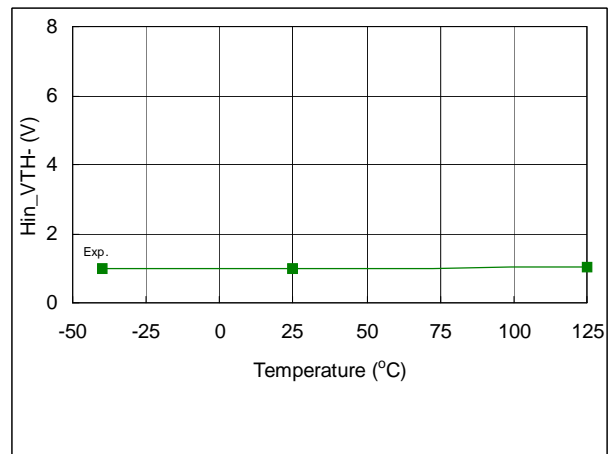
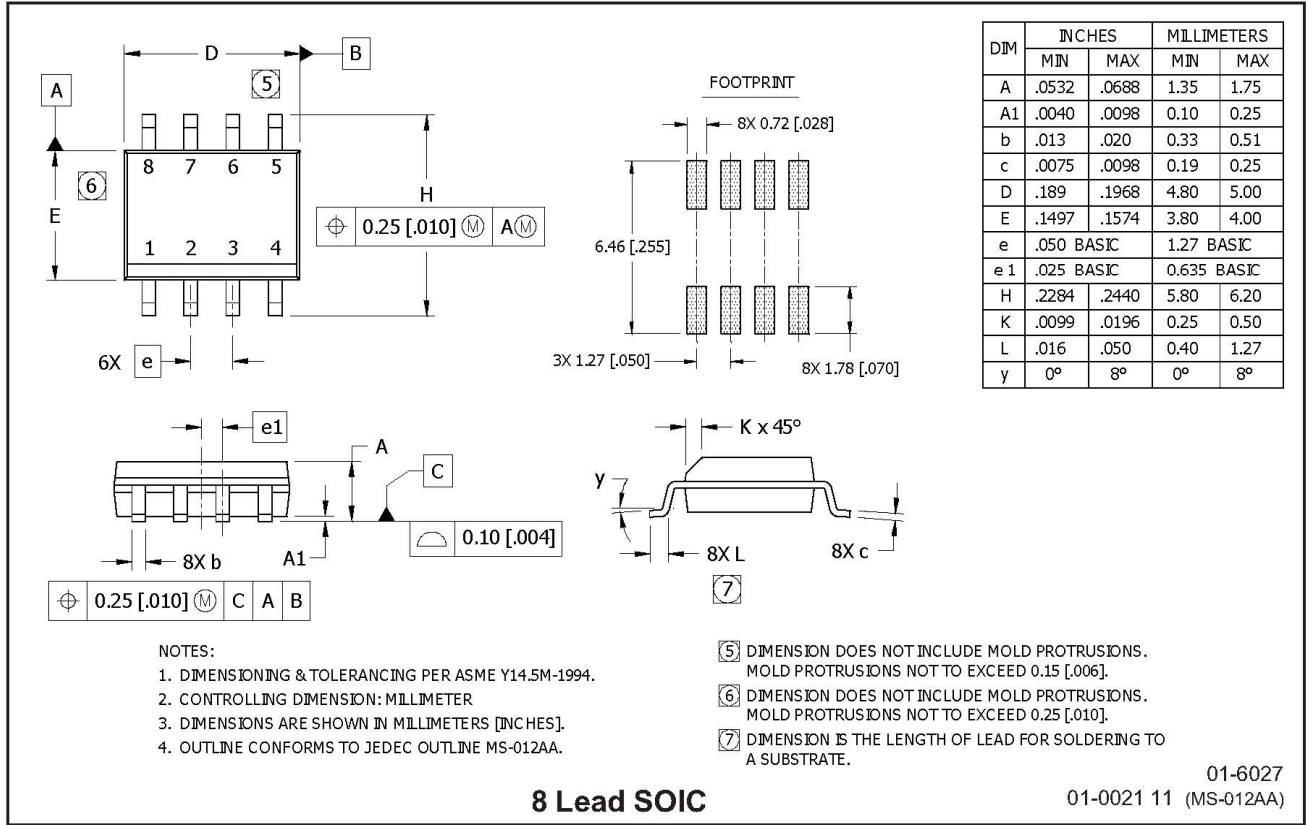
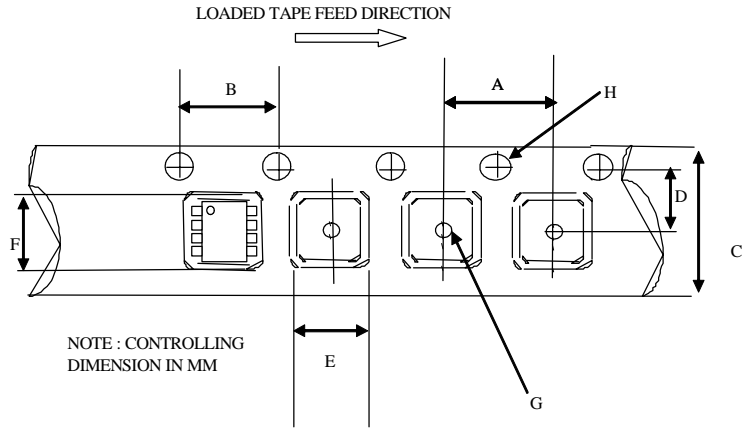

Figure 48. Hin_VTH- vs. Temperature

Package Details: 8-Lead SOIC



Tape and Reel Details: 8-Lead SOIC



CARRIER TAPE DIMENSION FOR 8SOICN

Code	Metric		Imperial	
	Min	Max	Min	Max
A	7.90	8.10	0.311	0.318
B	3.90	4.10	0.153	0.161
C	11.70	12.30	0.46	0.484
D	5.45	5.55	0.214	0.218
E	6.30	6.50	0.248	0.255
F	5.10	5.30	0.200	0.208
G	1.50	n/a	0.059	n/a
H	1.50	1.60	0.059	0.062

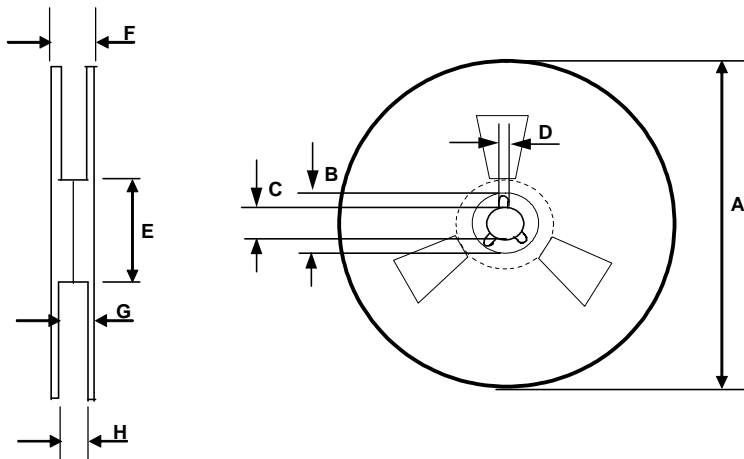

REEL DIMENSIONS FOR 8SOICN

Code	Metric		Imperial	
	Min	Max	Min	Max
A	329.60	330.25	12.976	13.001
B	20.95	21.45	0.824	0.844
C	12.80	13.20	0.503	0.519
D	1.95	2.45	0.767	0.096
E	98.00	102.00	3.858	4.015
F	n/a	18.40	n/a	0.724
G	14.50	17.10	0.570	0.673
H	12.40	14.40	0.488	0.566

Part Marking Information

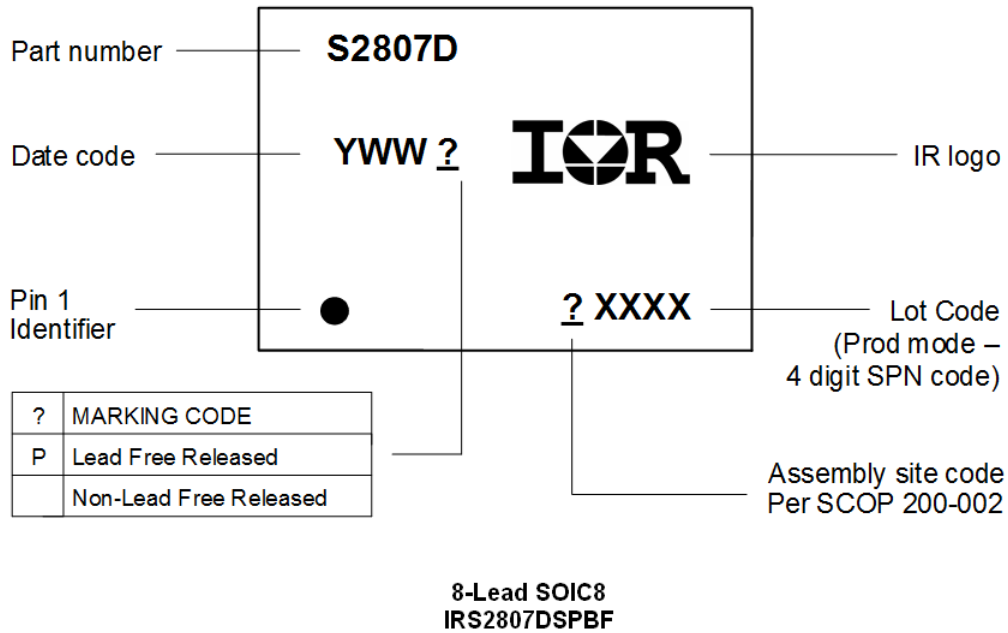
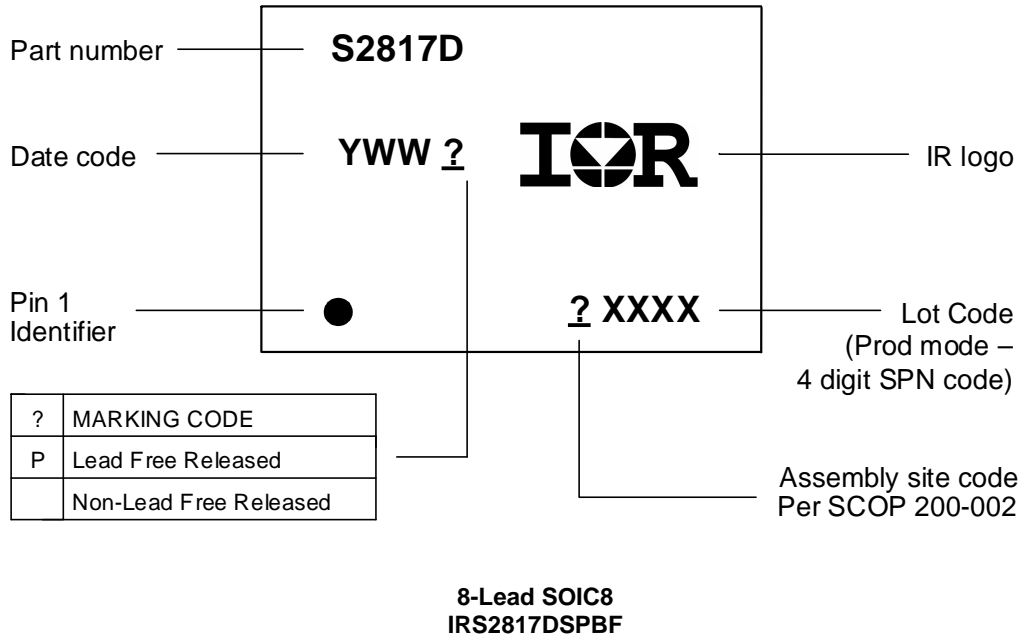

Qualification Information

Qualification Level		Industrial [†]	
		Comments: This family of ICs has passed JEDEC's Industrial qualification. IR's Consumer qualification level is granted by extension of the higher Industrial level.	
Moisture Sensitivity Level		8-Lead SOIC	MSL2 ^{††} , 260°C (per IPC/JEDEC J-STD-020)
ESD	Human Body Model	Class 1C (per JEDEC standard JESD22-A114)	
	Machine Model	Class B (per EIA/JEDEC standard EIA/JESD22-A115)	
IC Latch-Up Test		Class I, Level A (per JESD78)	
RoHS Compliant		Yes	

† Higher qualification ratings may be available should the user have such requirements. Please contact your Infineon sales representative for further information.

†† Higher MSL ratings may be available for the specific package types listed here. Please contact your Infineon sales representative for further information.

Published by
Infineon Technologies AG
81726 München, Germany
© Infineon Technologies AG 2017
All Rights Reserved.

IMPORTANT NOTICE

The information given in this document shall in no event be regarded as a guarantee of conditions or characteristics ("Beschaffheitsgarantie"). With respect to any examples, hints or any typical values stated herein and/or any information regarding the application of the product, Infineon Technologies hereby disclaims any and all warranties and liabilities of any kind, including without limitation warranties of non-infringement of intellectual property rights of any third party.

In addition, any information given in this document is subject to customer's compliance with its obligations stated in this document and any applicable legal requirements, norms and standards concerning customer's products and any use of the product of Infineon Technologies in customer's applications.

The data contained in this document is exclusively intended for technically trained staff. It is the responsibility of customer's technical departments to evaluate the suitability of the product for the intended application and the completeness of the product information given in this document with respect to such application.

For further information on the product, technology, delivery terms and conditions and prices please contact your nearest Infineon Technologies office (www.infineon.com).

WARNINGS

Due to technical requirements products may contain dangerous substances. For information on the types in question please contact your nearest Infineon Technologies office.

Except as otherwise explicitly approved by Infineon Technologies in a written document signed by authorized representatives of Infineon Technologies, Infineon Technologies' products may not be used in any applications where a failure of the product or any consequences of the use thereof can reasonably be expected to result in personal injury.



Компания «ЭлектроПласт» предлагает заключение долгосрочных отношений при поставках импортных электронных компонентов на взаимовыгодных условиях!

Наши преимущества:

- Оперативные поставки широкого спектра электронных компонентов отечественного и импортного производства напрямую от производителей и с крупнейших мировых складов;
- Поставка более 17-ти миллионов наименований электронных компонентов;
- Поставка сложных, дефицитных, либо снятых с производства позиций;
- Оперативные сроки поставки под заказ (от 5 рабочих дней);
- Экспресс доставка в любую точку России;
- Техническая поддержка проекта, помощь в подборе аналогов, поставка прототипов;
- Система менеджмента качества сертифицирована по Международному стандарту ISO 9001;
- Лицензия ФСБ на осуществление работ с использованием сведений, составляющих государственную тайну;
- Поставка специализированных компонентов (Xilinx, Altera, Analog Devices, Intersil, Interpoint, Microsemi, Aeroflex, Peregrine, Syfer, Eurofarad, Texas Instrument, Miteq, Cobham, E2V, MA-COM, Hittite, Mini-Circuits, General Dynamics и др.);

Помимо этого, одним из направлений компании «ЭлектроПласт» является направление «Источники питания». Мы предлагаем Вам помощь Конструкторского отдела:

- Подбор оптимального решения, техническое обоснование при выборе компонента;
- Подбор аналогов;
- Консультации по применению компонента;
- Поставка образцов и прототипов;
- Техническая поддержка проекта;
- Защита от снятия компонента с производства.



Как с нами связаться

Телефон: 8 (812) 309 58 32 (многоканальный)

Факс: 8 (812) 320-02-42

Электронная почта: org@eplast1.ru

Адрес: 198099, г. Санкт-Петербург, ул. Калинина, дом 2, корпус 4, литера А.