

Power CMOS Drivers With Voltage Tripler

Features

- Power Driver With On Board Voltage Booster
- Low I_{DD} – <4mA
- Small Package – 8-Pin PDIP
- Under-Voltage Circuitry
- Fast Rise-Fall Time – <40nsec @ 1000pF
- Below-Rail Input Protection

Applications

- Raises 5V to drive higher – V_{gs} (ON) MOSFETs
- Eliminates one system power supply

Device Selection Table

Part Number	Package	Temp. Range
TC4626COE	16-Pin SOIC (Wide)	-55°C to +125°C
TC4626CPA	8-Pin PDIP	-40°C to +85°C
TC4626EOE	16-Pin SOIC (Wide)	-40°C to +85°C
TC4626EPA	8-Pin PDIP	0°C to +70°C
TC4626MJA	8-Pin CERDIP	0°C to +70°C
TC4627COE	16-Pin SOIC (Wide)	-55°C to +125°C
TC4627CPA	8-Pin PDIP	-40°C to +85°C
TC4627EOE	16-Pin SOIC (Wide)	-40°C to +85°C
TC4627EPA	8-Pin PDIP	0°C to +70°C
TC4627MJA	8-Pin CERDIP	0°C to +70°C

Package Type



General Description

The TC4626/TC4627 are single CMOS high speed drivers with an on-board voltage boost circuit. These parts work with an input supply voltage from 4 to 6 volts. The internal voltage booster will produce a V_{BOOST} potential up to 12 volts above V_{IN} . This V_{BOOST} is not regulated, so its voltage is dependent on the input V_{DD} voltage and output drive loading requirements. An internal undervoltage lockout circuit keeps the output in a low state when V_{BOOST} drops below 7.8 volts. Output is enabled when V_{BOOST} is above 11.3 volts.

Functional Block Diagram



TC4626/TC4627

1.0 ELECTRICAL CHARACTERISTICS

Absolute Maximum Ratings*

Supply Voltage	6.2V
Input Voltage, Any Terminal	$V_S + 0.3V$ to $GND - 0.3V$
Package Power Dissipation ($T_A \leq 70^\circ C$)	
PDIP	730mW
CERDIP	800mW
SOIC	760mW
Derating Factor PDIP	5.6 mW/°C Above 36°C
CERDIP	6.0mW/°C
Operating Temperature Range (Ambient)	
C Version	0°C to +70°C
E Version	-40°C to +85°C
M Version	-55°C to +125°C
Storage Temperature Range	-65°C to +150°C

*Stresses above those listed under "Absolute Maximum Ratings" may cause permanent damage to the device. These are stress ratings only and functional operation of the device at these or any other conditions above those indicated in the operation sections of the specifications is not implied. Exposure to Absolute Maximum Rating conditions for extended periods may affect device reliability.

TC4626/TC4627 ELECTRICAL SPECIFICATIONS

Electrical Characteristics: $T_A = +25^\circ C$, $V_{DD} = 5V$, $C_1 = C_2 = C_3 = 10\mu F$ unless otherwise noted.						
Symbol	Parameter	Min	Typ	Max	Units	Test Conditions
Input						
V_{IH}	Logic 1, High Input Voltage	2.4	—	—	V	
V_{IL}	Logic 0, Low Input Voltage	—	—	0.8	V	
I_{IN}	Input Current	-1	—	1	μA	$0V \leq V_{IN} \leq V_{DRIVE}$
Output						
V_{OH}	High Output Voltage	$V_{BOOST} - 0.025$	—	—	V	
V_{OL}	Low Output Voltage	—	—	0.025	V	
R_O	Output Resistance, High	—	10	15	Ω	$I_{OUT} = 10mA$, $V_{DD} = 5V$
R_O	Output Resistance, Low	—	8	10	Ω	$I_{OUT} = 10mA$, $V_{DD} = 5V$
I_{PK}	Peak Output Current	—	1.5	—	A	
Switching Time						
t_R	Rise Time	—	33	40	nsec	Figure 3-1, Figure 3-2
t_F	Fall Time	—	27	35	nsec	Figure 3-1, Figure 3-2
t_{D1}	Delay Time	—	35	45	nsec	Figure 3-1, Figure 3-2
t_{D2}	Delay Time	—	45	55	nsec	Figure 3-1, Figure 3-2
F_{MAX}	Maximum Switching Frequency	1.0	—	—	MHz	$V_{DD} = 5V$, $V_{BOOST} > 8.5V$, Figure 3-1
Voltage Booster						
R_3	Voltage Tripler Output Source Resistance	—	300	400	Ω	$I_L = 10mA$, $V_{DD} = 5V$
R_2	Voltage Doubler Output Source Resistance	—	120	200	Ω	
F_{OSC}	Oscillator Frequency	12	—	28	kHz	
V_{OSC}	Oscillator Amplitude Measured at C1-	4.5	—	10	V	$R_{LOAD} = 10k\Omega$
$UV @ V_{BOOST}$	Undervoltage Threshold	7.0	7.8	8.5	V	
$V_{START} @ V_{BOOST}$	Start Up Voltage	10.5	11.3	12	V	
V_{BOOST}	@ $V_{DD} = 5V$	14.6	—	—	V	No Load

TC4626/TC4627

TC4626/TC4627 ELECTRICAL SPECIFICATIONS (CONTINUED)

Symbol	Parameter	Min	Typ	Max	Units	Test Conditions
Power Supply						
I _{DD}	Power Supply Current	—	—	2.5	mA	V _{IN} = LOW or HIGH
V _{DD}	Supply Voltage	4.0	—	6.0	V	
Electrical Characteristics: Over operating temperature range, V _{DD} = 5V, C ₁ = C ₂ = C ₃ 10μF unless otherwise noted.						
Symbol	Parameter	Min	Typ	Max	Units	Test Conditions
Input						
V _{IH}	Logic 1, High Input Voltage	2.4	—	—	V	
V _{IL}	Logic 0, Low Input Voltage	—	—	0.8	V	
I _{IN}	Input Current	-10	—	1	μA	0V ≤ V _{IN} ≤ V _{BOOST}
Output						
V _{OH}	High Output Voltage	V _{DRIVE} - 0.025	—	—	V	
V _{OL}	Low Output Voltage	—	—	0.025	V	
R _O	Output Resistance, High	—	15 15	20 25	Ω	I _{OUT} = 10mA, V _{DD} = 5V C & E Version (T _A = 70°C or 85°C) M Version (T _A = 125°C)
R _O	Output Resistance, Low	—	10 10	13 15	Ω	I _{OUT} = 10mA, V _{DD} = 5V C & E Version (T _A = 70°C or 85°C) M Version (T _A = 125°C)
I _{PK}	Peak Output Current	—	1.5	—	A	
Switching Time						
t _R	Rise Time	—	—	55	nsec	Figure 3-1, Figure 3-2
t _F	Fall Time	—	—	50	nsec	Figure 3-1, Figure 3-2
t _{D1}	Delay Time	—	—	60	nsec	Figure 3-1, Figure 3-2
t _{D2}	Delay Time	—	—	70	nsec	Figure 3-1, Figure 3-2
F _{MAX}	Maximum Switching Frequency	750	—	—	kHz	V _{DD} = 5V, V _{BOOST} > 8.5V, Figure 3-1
Voltage Booster						
R ₃	Voltage Boost Output Source Resistance	—	400	500	Ω	I _L = 10mA, V _{DD} = 5V
R ₂	Voltage Doubler Output Source Resistance	—	170	300	Ω	
F _{OSC}	Oscillator Frequency	5	—	50	kHz	
V _{OSC}	Oscillator Amplitude Measured at C1-	4.5	—	10	V	R _{LOAD} = 10kΩ
UV @V _{BOOST}	Undervoltage Threshold	7.0	7.8	8.5	V	
V _{START} @V _{BOOST}	Start Up Voltage	10.5	11.3	12	V	
V _{BOOST}	@V _{DD} = 5V	14.6	—	—	V	No Load
Power Supply						
I _{DD}	Power Supply Current	—	—	4	mA	V _{IN} = LOW or HIGH
V _{DD}	Supply Voltage	4.0	—	6.0	V	

TC4626/TC4627

2.0 PIN DESCRIPTIONS

The descriptions of the pins are listed in Table 2-1.

TABLE 2-1: PIN FUNCTION TABLE

Pin No. (8-Pin PDIP, CERDIP)	Symbol	Description
1	C1-	
2	C1+	
3	C2	
4	GND	Ground.
5	OUT	
6	V _{BOOST}	
7	IN	
8	V _{DD}	

Pin No. (16-Pin SOIC Wide)	Symbol	Description
1	C1-	
2	NC	No connect.
3	C1+	
4	NC	No connect.
5	C2	
6	NC	No connect.
7	NC	No connect.
8	GND	Ground.
9	OUT	
10	NC	No connect.
11	V _{BOOST}	
12	NC	No connect.
13	IN	
14	NC	No connect.
15	NC	No connect.
16	V _{DD}	

3.0 APPLICATIONS INFORMATION

FIGURE 3-1: INVERTING DRIVER SWITCHING TIME



FIGURE 3-2: NONINVERTING DRIVER SWITCHING TIME



TC4626/TC4627

3.1 BOOSTER FUNCTION

The voltage booster is an unregulated voltage tripler circuit. The tripler consists of three sets of internal switches and three external capacitors. S1a and S1b charge capacitor C1 to V_{DD} potential. S2a and S2b add

C1 potential to V_{DD} input to charge C2 to $2 \times V_{DD}$. S3a and S3b add C1 potential to C2 to charge C3 to $3 \times V_{DD}$. The position of the switches is controlled by the internal 4 phase clock.

FIGURE 3-3: VOLTAGE BOOSTER

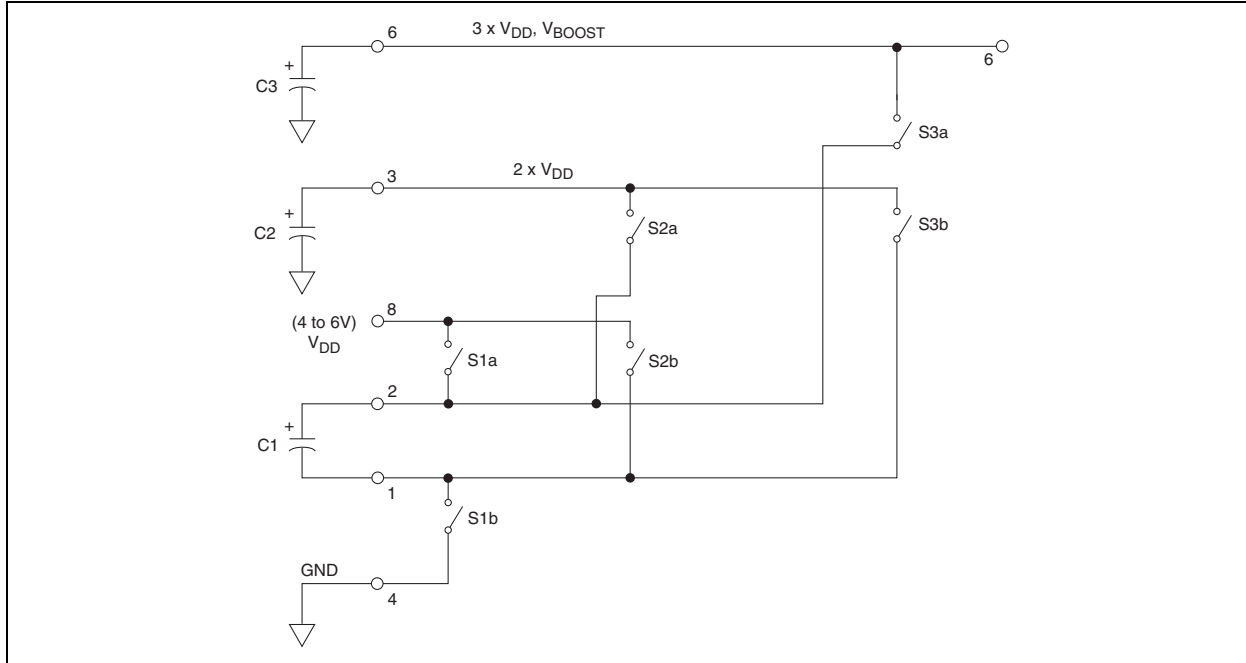
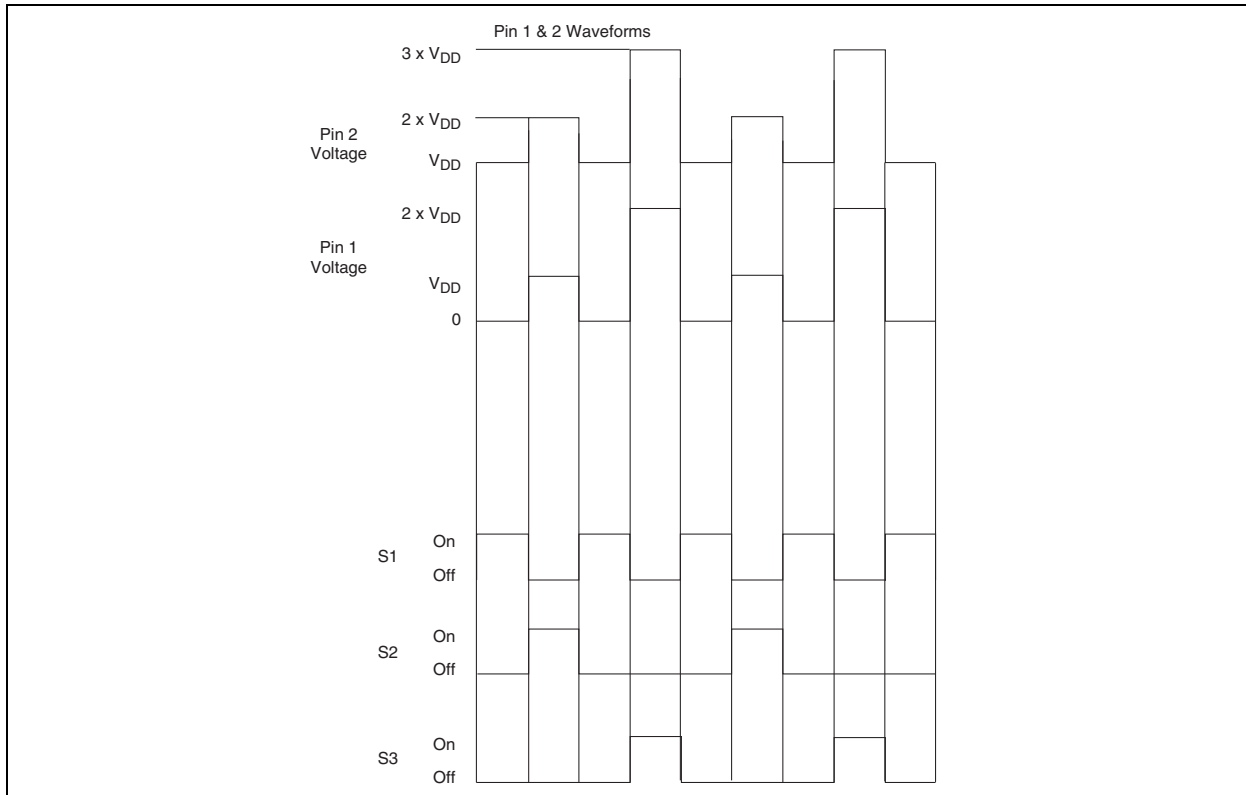

FIGURE 3-4: POSITION OF SWITCHES



4.0 TYPICAL CHARACTERISTICS

Note: The graphs and tables provided following this note are a statistical summary based on a limited number of samples and are provided for informational purposes only. The performance characteristics listed herein are not tested or guaranteed. In some graphs or tables, the data presented may be outside the specified operating range (e.g., outside specified power supply range) and therefore outside the warranted range.



TC4626/TC4627

TYPICAL CHARACTERISTICS (CONTINUED)

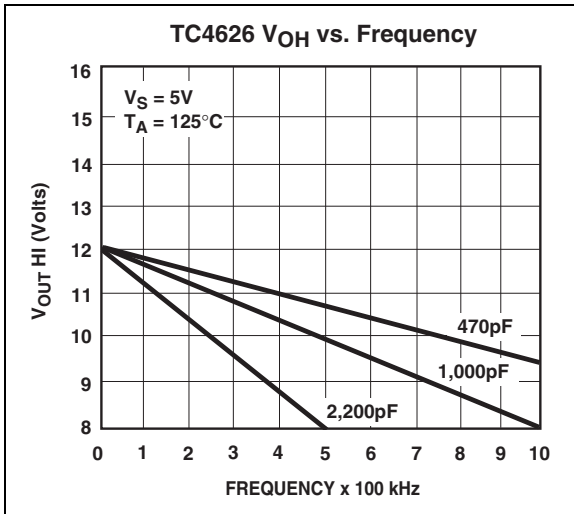
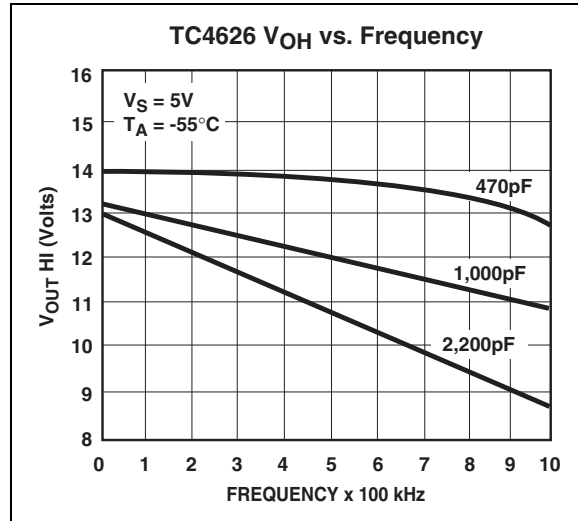
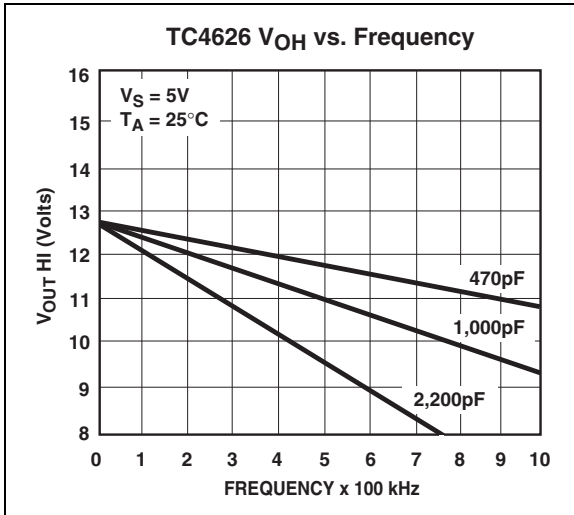

5.0 PACKAGING INFORMATION

Package marking data not available at this time.

TC4626/TC4627

5.1 Package Dimensions

Note: For the most current package drawings, please see the Microchip Packaging Specification located at <http://www.microchip.com/packaging>

8-Pin Plastic DIP



Dimensions: inches (mm)

Package Dimensions (Continued)

Note: For the most current package drawings, please see the Microchip Packaging Specification located at <http://www.microchip.com/packaging>

8-Pin CDIP (Narrow)



Dimensions: inches (mm)

TC4626/TC4627

Package Dimensions (Continued)

Note: For the most current package drawings, please see the Microchip Packaging Specification located at <http://www.microchip.com/packaging>

16-Pin SOIC (Wide)



Dimensions: inches (mm)

6.0 REVISION HISTORY

Revision C (December 2012)

Added a note to each package outline drawing.

Sales and Support

Data Sheets

Products supported by a preliminary Data Sheet may have an errata sheet describing minor operational differences and recommended workarounds. To determine if an errata sheet exists for a particular device, please contact one of the following:

1. Your local Microchip sales office
2. The Microchip Worldwide Site (www.microchip.com)

Please specify which device, revision of silicon and Data Sheet (include Literature #) you are using.

New Customer Notification System

Register on our web site (www.microchip.com/cn) to receive the most current information on our products.

TC4626/TC4627

NOTES:

Note the following details of the code protection feature on Microchip devices:

- Microchip products meet the specification contained in their particular Microchip Data Sheet.
- Microchip believes that its family of products is one of the most secure families of its kind on the market today, when used in the intended manner and under normal conditions.
- There are dishonest and possibly illegal methods used to breach the code protection feature. All of these methods, to our knowledge, require using the Microchip products in a manner outside the operating specifications contained in Microchip's Data Sheets. Most likely, the person doing so is engaged in theft of intellectual property.
- Microchip is willing to work with the customer who is concerned about the integrity of their code.
- Neither Microchip nor any other semiconductor manufacturer can guarantee the security of their code. Code protection does not mean that we are guaranteeing the product as “unbreakable.”

Code protection is constantly evolving. We at Microchip are committed to continuously improving the code protection features of our products. Attempts to break Microchip's code protection feature may be a violation of the Digital Millennium Copyright Act. If such acts allow unauthorized access to your software or other copyrighted work, you may have a right to sue for relief under that Act.

Information contained in this publication regarding device applications and the like is provided only for your convenience and may be superseded by updates. It is your responsibility to ensure that your application meets with your specifications. MICROCHIP MAKES NO REPRESENTATIONS OR WARRANTIES OF ANY KIND WHETHER EXPRESS OR IMPLIED, WRITTEN OR ORAL, STATUTORY OR OTHERWISE, RELATED TO THE INFORMATION, INCLUDING BUT NOT LIMITED TO ITS CONDITION, QUALITY, PERFORMANCE, MERCHANTABILITY OR FITNESS FOR PURPOSE. Microchip disclaims all liability arising from this information and its use. Use of Microchip devices in life support and/or safety applications is entirely at the buyer's risk, and the buyer agrees to defend, indemnify and hold harmless Microchip from any and all damages, claims, suits, or expenses resulting from such use. No licenses are conveyed, implicitly or otherwise, under any Microchip intellectual property rights.

Trademarks

The Microchip name and logo, the Microchip logo, dsPIC, FlashFlex, KEELOQ, KEELOQ logo, MPLAB, PIC, PICmicro, PICSTART, PIC³² logo, rPIC, SST, SST Logo, SuperFlash and UNI/O are registered trademarks of Microchip Technology Incorporated in the U.S.A. and other countries.

FilterLab, Hampshire, HI-TECH C, Linear Active Thermistor, MTP, SEEVAL and The Embedded Control Solutions Company are registered trademarks of Microchip Technology Incorporated in the U.S.A.

Silicon Storage Technology is a registered trademark of Microchip Technology Inc. in other countries.

Analog-for-the-Digital Age, Application Maestro, BodyCom, chipKIT, chipKIT logo, CodeGuard, dsPICDEM, dsPICDEM.net, dsPICworks, dsSPEAK, ECAN, ECONOMONITOR, FanSense, HI-TIDE, In-Circuit Serial Programming, ICSP, Mindi, MiWi, MPASM, MPF, MPLAB Certified logo, MPLIB, MPLINK, mTouch, Omniclient Code Generation, PICC, PICC-18, PICDEM, PICDEM.net, PICkit, PICtail, REAL ICE, rLAB, Select Mode, SQI, Serial Quad I/O, Total Endurance, TSHARC, UniWinDriver, WiperLock, ZENA and Z-Scale are trademarks of Microchip Technology Incorporated in the U.S.A. and other countries.

SQTP is a service mark of Microchip Technology Incorporated in the U.S.A.

GestIC and ULPP are registered trademarks of Microchip Technology Germany II GmbH & Co. & KG, a subsidiary of Microchip Technology Inc., in other countries.

All other trademarks mentioned herein are property of their respective companies.

© 2001-2012, Microchip Technology Incorporated, Printed in the U.S.A., All Rights Reserved.

 Printed on recycled paper.

ISBN: 9781620768006

QUALITY MANAGEMENT SYSTEM
CERTIFIED BY DNV
== ISO/TS 16949 ==

Microchip received ISO/TS-16949:2009 certification for its worldwide headquarters, design and wafer fabrication facilities in Chandler and Tempe, Arizona; Gresham, Oregon and design centers in California and India. The Company's quality system processes and procedures are for its PIC[®] MCUs and dsPIC[®] DSCs, KEELOQ[®] code hopping devices, Serial EEPROMs, microperipherals, nonvolatile memory and analog products. In addition, Microchip's quality system for the design and manufacture of development systems is ISO 9001:2000 certified.



MICROCHIP

Worldwide Sales and Service

AMERICAS

Corporate Office
2355 West Chandler Blvd.
Chandler, AZ 85224-6199
Tel: 480-792-7200
Fax: 480-792-7277
Technical Support:
<http://www.microchip.com/support>
Web Address:
www.microchip.com

Atlanta
Duluth, GA
Tel: 678-957-9614
Fax: 678-957-1455

Boston
Westborough, MA
Tel: 774-760-0087
Fax: 774-760-0088

Chicago
Itasca, IL
Tel: 630-285-0071
Fax: 630-285-0075

Cleveland
Independence, OH
Tel: 216-447-0464
Fax: 216-447-0643

Dallas
Addison, TX
Tel: 972-818-7423
Fax: 972-818-2924

Detroit
Farmington Hills, MI
Tel: 248-538-2250
Fax: 248-538-2260

Indianapolis
Noblesville, IN
Tel: 317-773-8323
Fax: 317-773-5453

Los Angeles
Mission Viejo, CA
Tel: 949-462-9523
Fax: 949-462-9608

Santa Clara
Santa Clara, CA
Tel: 408-961-6444
Fax: 408-961-6445

Toronto
Mississauga, Ontario,
Canada
Tel: 905-673-0699
Fax: 905-673-6509

ASIA/PACIFIC

Asia Pacific Office
Suites 3707-14, 37th Floor
Tower 6, The Gateway
Harbour City, Kowloon
Hong Kong
Tel: 852-2401-1200
Fax: 852-2401-3431

Australia - Sydney
Tel: 61-2-9868-6733
Fax: 61-2-9868-6755

China - Beijing
Tel: 86-10-8569-7000
Fax: 86-10-8528-2104

China - Chengdu
Tel: 86-28-8665-5511
Fax: 86-28-8665-7889

China - Chongqing
Tel: 86-23-8980-9588
Fax: 86-23-8980-9500

China - Hangzhou
Tel: 86-571-2819-3187
Fax: 86-571-2819-3189

China - Hong Kong SAR
Tel: 852-2943-5100
Fax: 852-2401-3431

China - Nanjing
Tel: 86-25-8473-2460
Fax: 86-25-8473-2470

China - Qingdao
Tel: 86-532-8502-7355
Fax: 86-532-8502-7205

China - Shanghai
Tel: 86-21-5407-5533
Fax: 86-21-5407-5066

China - Shenyang
Tel: 86-24-2334-2829
Fax: 86-24-2334-2393

China - Shenzhen
Tel: 86-755-8864-2200
Fax: 86-755-8203-1760

China - Wuhan
Tel: 86-27-5980-5300
Fax: 86-27-5980-5118

China - Xian
Tel: 86-29-8833-7252
Fax: 86-29-8833-7256

China - Xiamen
Tel: 86-592-2388138
Fax: 86-592-2388130

China - Zhuhai
Tel: 86-756-3210040
Fax: 86-756-3210049

ASIA/PACIFIC

India - Bangalore
Tel: 91-80-3090-4444
Fax: 91-80-3090-4123

India - New Delhi
Tel: 91-11-4160-8631
Fax: 91-11-4160-8632

India - Pune
Tel: 91-20-2566-1512
Fax: 91-20-2566-1513

Japan - Osaka
Tel: 81-66-152-7160
Fax: 81-66-152-9310

Japan - Yokohama
Tel: 81-45-471-6166
Fax: 81-45-471-6122

Korea - Daegu
Tel: 82-53-744-4301
Fax: 82-53-744-4302

Korea - Seoul
Tel: 82-2-554-7200
Fax: 82-2-558-5932 or
82-2-558-5934

Malaysia - Kuala Lumpur
Tel: 60-3-6201-9857
Fax: 60-3-6201-9859

Malaysia - Penang
Tel: 60-4-227-8870
Fax: 60-4-227-4068

Philippines - Manila
Tel: 63-2-634-9065
Fax: 63-2-634-9069

Singapore
Tel: 65-6334-8870
Fax: 65-6334-8850

Taiwan - Hsin Chu
Tel: 886-3-5778-366
Fax: 886-3-5770-955

Taiwan - Kaohsiung
Tel: 886-7-213-7828
Fax: 886-7-330-9305

Taiwan - Taipei
Tel: 886-2-2508-8600
Fax: 886-2-2508-0102

Thailand - Bangkok
Tel: 66-2-694-1351
Fax: 66-2-694-1350

EUROPE

Austria - Wels
Tel: 43-7242-2244-39
Fax: 43-7242-2244-393

Denmark - Copenhagen
Tel: 45-4450-2828
Fax: 45-4485-2829

France - Paris
Tel: 33-1-69-53-63-20
Fax: 33-1-69-30-90-79

Germany - Munich
Tel: 49-89-627-144-0
Fax: 49-89-627-144-44

Italy - Milan
Tel: 39-0331-742611
Fax: 39-0331-466781

Netherlands - Drunen
Tel: 31-416-690399
Fax: 31-416-690340

Spain - Madrid
Tel: 34-91-708-08-90
Fax: 34-91-708-08-91

UK - Wokingham
Tel: 44-118-921-5869
Fax: 44-118-921-5820

11/27/12



Компания «ЭлектроПласт» предлагает заключение долгосрочных отношений при поставках импортных электронных компонентов на взаимовыгодных условиях!

Наши преимущества:

- Оперативные поставки широкого спектра электронных компонентов отечественного и импортного производства напрямую от производителей и с крупнейших мировых складов;
- Поставка более 17-ти миллионов наименований электронных компонентов;
- Поставка сложных, дефицитных, либо снятых с производства позиций;
- Оперативные сроки поставки под заказ (от 5 рабочих дней);
- Экспресс доставка в любую точку России;
- Техническая поддержка проекта, помощь в подборе аналогов, поставка прототипов;
- Система менеджмента качества сертифицирована по Международному стандарту ISO 9001;
- Лицензия ФСБ на осуществление работ с использованием сведений, составляющих государственную тайну;
- Поставка специализированных компонентов (Xilinx, Altera, Analog Devices, Intersil, Interpoint, Microsemi, Aeroflex, Peregrine, Syfer, Eurofarad, Texas Instrument, Miteq, Cobham, E2V, MA-COM, Hittite, Mini-Circuits, General Dynamics и др.);

Помимо этого, одним из направлений компании «ЭлектроПласт» является направление «Источники питания». Мы предлагаем Вам помощь Конструкторского отдела:

- Подбор оптимального решения, техническое обоснование при выборе компонента;
- Подбор аналогов;
- Консультации по применению компонента;
- Поставка образцов и прототипов;
- Техническая поддержка проекта;
- Защита от снятия компонента с производства.



Как с нами связаться

Телефон: 8 (812) 309 58 32 (многоканальный)

Факс: 8 (812) 320-02-42

Электронная почта: org@eplast1.ru

Адрес: 198099, г. Санкт-Петербург, ул. Калинина, дом 2, корпус 4, литера А.