

## High Temperature Accuracy Integrated Silicon Pressure Sensor for Measuring Vacuum/Gauge Pressure, On-Chip Signal Conditioned, Temperature Compensated and Calibrated

### MPXV5050V Series

-50 to 0 kPa (-7.25 to 0 psi)  
0.1 to 4.6 V Output

The MPXV5050V series sensor integrates on-chip, bipolar op amp circuitry and thin film resistor networks to provide a high output signal and temperature compensation. The small form factor and high reliability of on-chip integration make the NXP Semiconductor pressure sensor a logical and economical choice for the system designer.

The MPXV5050V series piezoresistive transducer is a state-of-the-art, monolithic, signal conditioned, silicon pressure sensor. This sensor combines advanced micromachining techniques, thin film metallization, and bipolar semiconductor processing to provide an accurate, high level analog output signal that is proportional to applied pressure.

### Features

- 2.5% Maximum Error over 0° to 85°C
- Ideally suited for Microprocessor or Microcontroller-Based Systems
- Temperature Compensated from Over -40° to +125°C
- Patented Silicon Shear Stress Strain Gauge
- Durable Thermoplastic (PPS) Surface Mount Package
- Easy-to-Use Chip Carrier Option
- Ideal for Automotive and Non-Automotive Applications

### Application Examples

- Vacuum Pump Monitoring

### ORDERING INFORMATION

Device Name	Case No.	# of Ports			Pressure Type			Device Marking
		None	Single	Dual	Gauge	Differential	Absolute	
<b>Small Outline Package</b>								
MPXV5050VC6T1	482A		•		Vacuum/Gauge			MPXV5050V

### SMALL OUTLINE PACKAGE

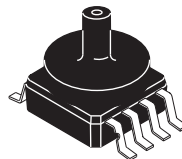

MPXV5050VC6T1  
CASE 482A-01

## Operating Characteristics

**Table 1. Operating Characteristics** ( $V_S = 5.0$  Vdc,  $T_A = 25^\circ\text{C}$  unless otherwise noted,  $P_1 > P_2$ )

Characteristic	Symbol	Min	Typ	Max	Unit
Pressure Range	$P_{OP}$	-50	—	0	kPa
Supply Voltage <sup>(1)</sup>	$V_S$	4.75	5.0	5.25	Vdc
Supply Current	$I_o$	—	7.0	10	mAdc
Full Scale Output <sup>(2)</sup> @ $V_S = 5.0$ Volts (0 to 85°C)	$V_{FSO}$	4.488	4.6	4.713	Vdc
Full Scale Span <sup>(3)</sup> @ $V_S = 5.0$ Volts (0 to 85°C)	$V_{FSS}$	—	4.5	—	Vdc
Accuracy <sup>(4)</sup> (0 to 85°C)	—	—	—	±2.5	% $V_{FSS}$
Sensitivity	V/P	—	90	—	mV/kPa
Response Time <sup>(5)</sup>	$t_R$	—	1.0	—	ms
Warm-Up Time <sup>(6)</sup>	—	—	20	—	ms
Offset Stability <sup>(7)</sup>	—	—	±0.5	—	% $V_{FSS}$
Pressure Offset <sup>(8)</sup> (0 to 85°C)	$V_{off}$	0	0.100	0.213	Vdc

1. Device is ratiometric within this specified excitation range.
2. Full Scale Output ( $V_{FSO}$ ) is defined as the output voltage at the maximum or full rated pressure.
3. Full Scale Span ( $V_{FSS}$ ) is defined as the algebraic difference between the output voltage at full rated pressure and the output voltage at the minimum rated pressure.
4. Accuracy is the deviation in actual output from nominal output over the entire pressure range and temperature range as a percent of span at 25°C due to all sources of error including the following:
  - Linearity: Output deviation from a straight line relationship with pressure over the specified pressure range.
  - Temperature Hysteresis: Output deviation at any temperature within the operating temperature range, after the temperature is cycled to and from the minimum or maximum operating temperature points, with zero differential pressure applied.
  - Pressure Hysteresis: Output deviation at any pressure within the specified range, when this pressure is cycled to and from minimum or maximum rated pressure at 25°C.
  - TcSpan: Output deviation over the temperature range of 0° to 85°C, relative to 25°C.
  - TcOffset: Output deviation with minimum pressure applied, over the temperature range of 0° to 85°C, relative to 25°C.
5. Response Time is defined as the time for the incremental change in the output to go from 10% to 90% of its final value when subjected to a specified step change in pressure.
6. Warm-up Time is defined as the time required for the product to meet the specified output voltage after the pressure has been stabilized.
7. Offset Stability is the product's output deviation when subjected to 1000 cycles of Pulsed Pressure, Temperature Cycling with Bias Test.
8. Offset ( $V_{off}$ ) is defined as the output voltage at the minimum rated pressure.

## Maximum Ratings

**Table 2. Maximum Ratings<sup>(1)</sup>**

Rating	Symbol	Value	Units
Maximum Pressure (P1 > P2)	$P_{max}$	200	kPa
Storage Temperature	$T_{stg}$	-40 to +125	°C
Operating Temperature	$T_A$	-40 to +125	°C

1. Exposure beyond the specified limits may cause permanent damage or degradation to the device.

Figure 1 shows a block diagram of the internal circuitry integrated on a pressure sensor chip.

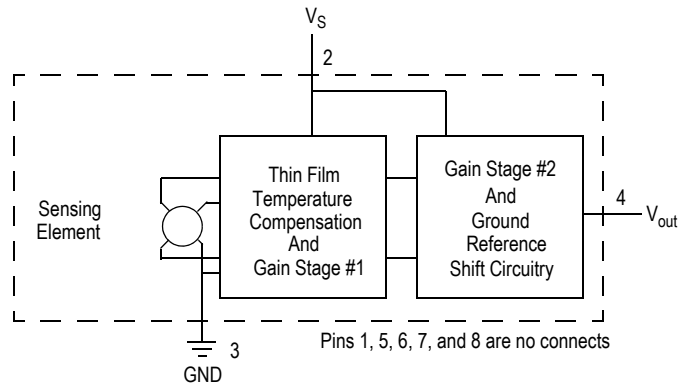

**Figure 1. Fully integrated pressure sensor schematic**

**Figure 2. Full device pinout (top view)**

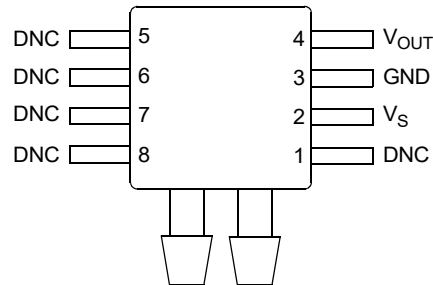

**Table 3. Pin functions**

Pin	Name	Function
1	DNC	Do not connect to external circuitry or ground.
2	$V_S$	Voltage supply
3	GND	Ground
4	$V_{OUT}$	Output voltage
5	DNC	Do not connect to external circuitry or ground.
6	DNC	Do not connect to external circuitry or ground.
7	DNC	Do not connect to external circuitry or ground.
8	DNC	Do not connect to external circuitry or ground.

## On-chip Temperature Compensation and Calibration

Figure 3 illustrates the gauge sensing chip in the basic Super Small Outline chip carrier (Case 482A).

Figure 4 shows a typical application circuit (output source current operation).

Figure 5 shows the sensor output signal relative to pressure input. Typical minimum and maximum output curves are shown for operation over 0 °C to 85 °C temperature range. The output will saturate outside of the rated pressure range.

A fluorosilicone gel isolates the die surface and wire bonds from the environment, while allowing the pressure signal to be transmitted to the silicon diaphragm. The MPXV5050 series pressure sensor operating characteristics, internal reliability and qualification tests are based on use of dry air as the pressure media. Media other than dry air may have adverse effects on sensor performance and long-term reliability. Contact the factory for information regarding media compatibility in your application.

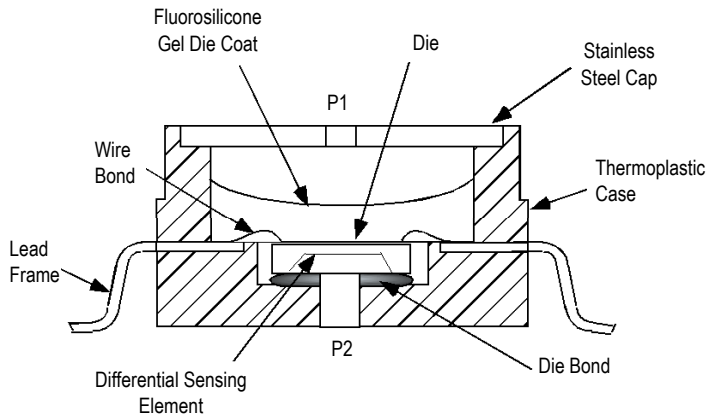

Figure 3. Cross Sectional Diagram SSOP (not to scale)

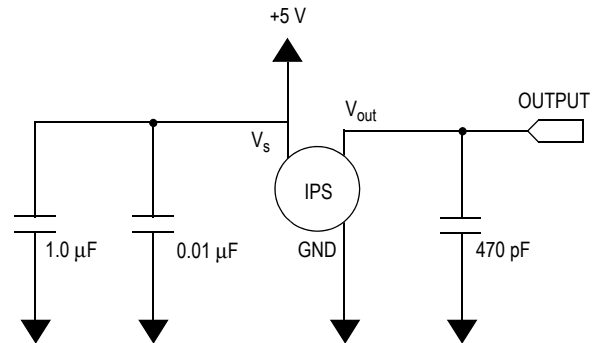

Figure 4. Typical Application Circuit (Output Source Current Operation)

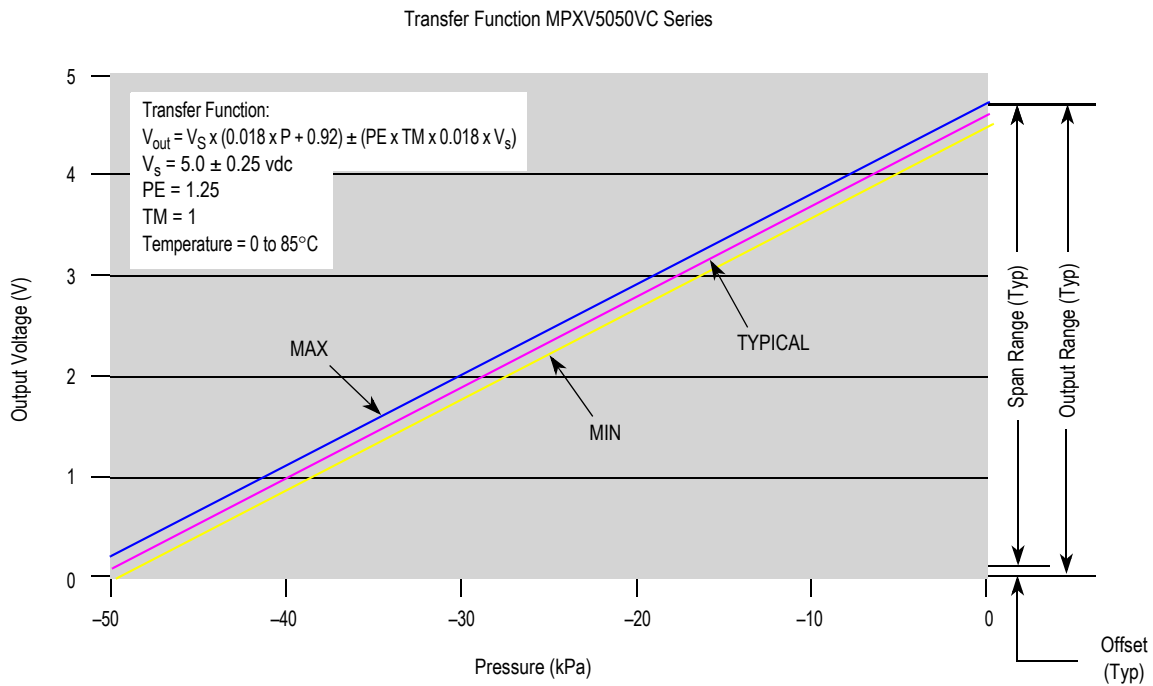
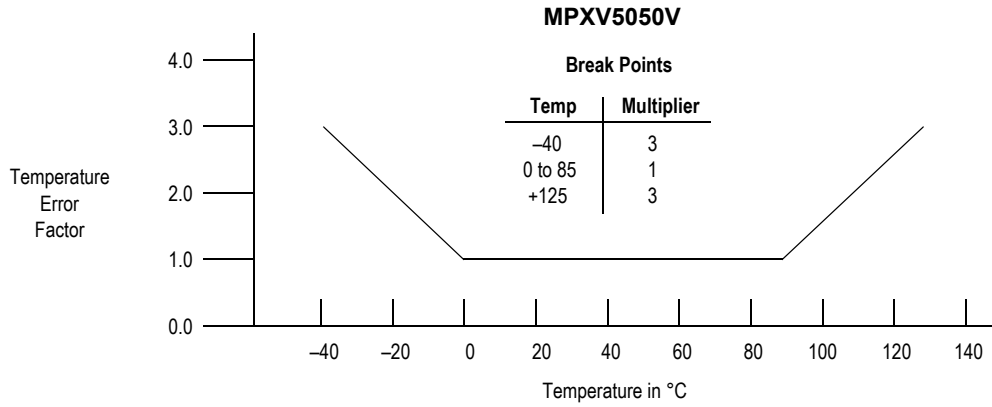

Figure 5. Output vs. Gauge Pressure

**Transfer Function (MPXV5050V)**

**Nominal Transfer Value:**  $V_{OUT} = V_S \times (0.018 \times P + 0.92)$   
 $\pm (\text{Pressure Error} \times \text{Temp Multi} \times 0.018 \times V_S)$   
 $V_S = 5.0 \pm 0.25 \text{ V}$

**Temperature Error Band**



NOTE: The Temperature Multiplier is a linear response from 0°C to -40°C and from 85°C to 125°C.

**Pressure Error Band**

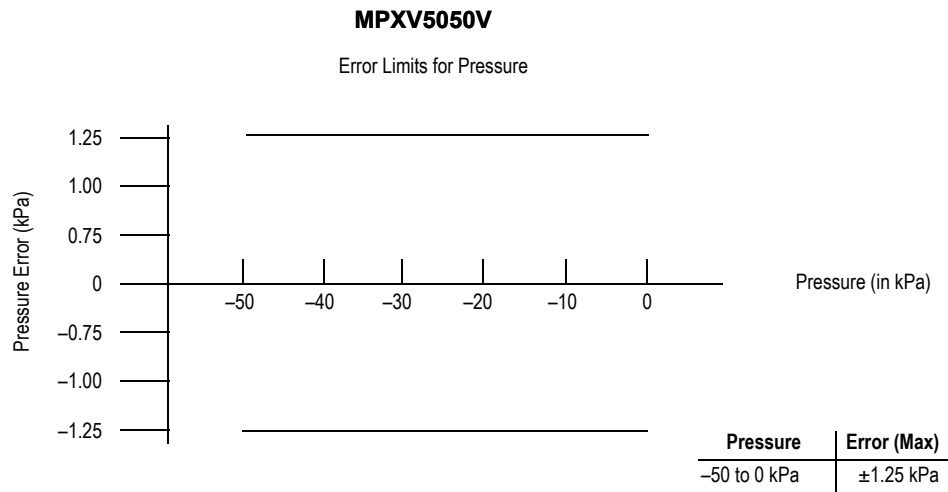

**SURFACE MOUNTING INFORMATION**

**MINIMUM RECOMMENDED FOOTPRINT FOR SMALL OUTLINE PACKAGE**

Surface mount board layout is a critical portion of the total design. The footprint for the semiconductor package must be the correct size to ensure proper solder connection interface between the board and the package. With the correct pad geometry, the packages will self-align when subjected to a

solder reflow process. It is always recommended to fabricate boards with a solder mask layer to avoid bridging and/or shorting between solder pads, especially on tight tolerances and/or tight layouts.

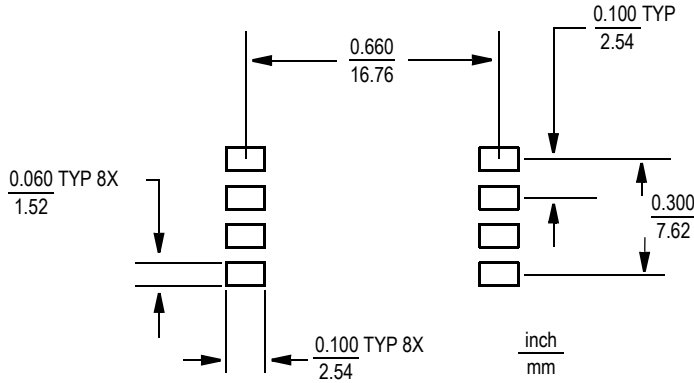

**Figure 6. SOP Footprint (Case 482A)**

PACKAGE DIMENSIONS

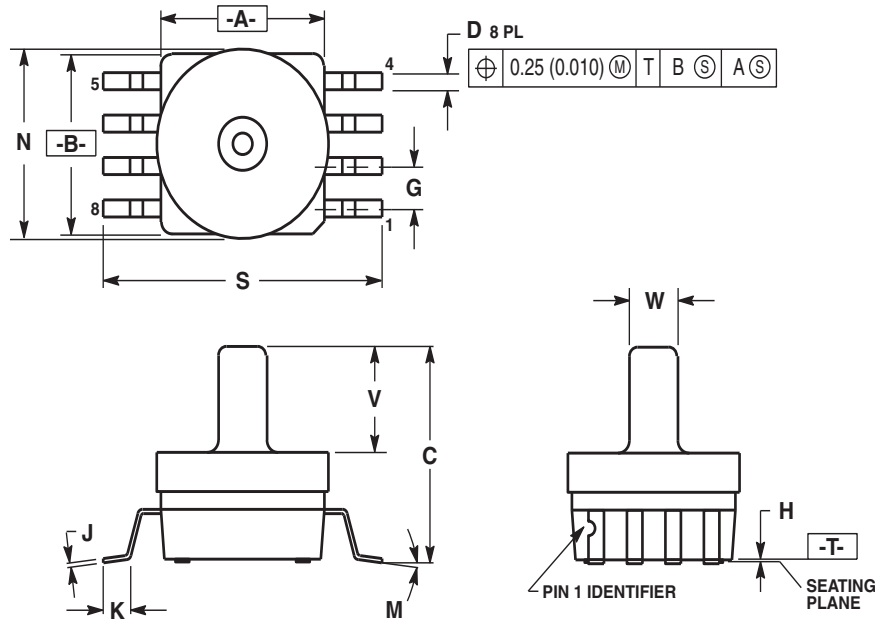

- NOTES:  
 1. DIMENSIONING AND TOLERANCING PER ANSI Y14.5M, 1982.  
 2. CONTROLLING DIMENSION: INCH.  
 3. DIMENSION A AND B DO NOT INCLUDE MOLD PROTRUSION.  
 4. MAXIMUM MOLD PROTRUSION 0.15 (0.006).  
 5. ALL VERTICAL SURFACES 5° TYPICAL DRAFT.

DIM	INCHES		MILLIMETERS	
	MIN	MAX	MIN	MAX
A	0.415	0.425	10.54	10.79
B	0.415	0.425	10.54	10.79
C	0.500	0.520	12.70	13.21
D	0.038	0.042	0.96	1.07
G	0.100 BSC		2.54 BSC	
H	0.002	0.010	0.05	0.25
J	0.009	0.011	0.23	0.28
K	0.061	0.071	1.55	1.80
M	0"	7"	0"	7"
N	0.444	0.448	11.28	11.38
S	0.709	0.725	18.01	18.41
V	0.245	0.255	6.22	6.48
W	0.115	0.125	2.92	3.17

CASE 482A-01  
 ISSUE A  
 SMALL OUTLINE PACKAGE

Table 4. Revision history

Revision number	Revision date	Description of changes
3	12/2018	<ul style="list-style-type: none"> <li>Revised "Freescale" references to "NXP" throughout document.</li> <li>Revised "absolute" references to "vacuum/gauge" or "gauge" throughout document.</li> <li>Inserted new figure titled "Full device pinout (topview)" as <a href="#">Figure 2</a>.</li> <li>Inserted new table titled "Pin functions" as <a href="#">Table 3</a>.</li> <li>Added the revision history as <a href="#">Table 4</a>.</li> </ul>

## **How to Reach Us:**

**Home Page:**  
www.nxp.com

**Web Support:**  
<http://www.nxp.com/support>

Information in this document is provided solely to enable system and software implementers to use NXP products. There are no expressed or implied copyright licenses granted hereunder to design or fabricate any integrated circuits based on the information in this document. NXP reserves the right to make changes without further notice to any products herein.

NXP makes no warranty, representation, or guarantee regarding the suitability of its products for any particular purpose, nor does NXP assume any liability arising out of the application or use of any product or circuit, and specifically disclaims any and all liability, including without limitation, consequential or incidental damages. "Typical" parameters that may be provided in NXP data sheets and/or specifications can and do vary in different applications, and actual performance may vary over time. All operating parameters, including "typicals," must be validated for each customer application by the customer's technical experts. NXP does not convey any license under its patent rights nor the rights of others. NXP sells products pursuant to standard terms and conditions of sale, which can be found at the following address:

<http://www.nxp.com/terms-of-use.html>.

NXP and the NXP logo are trademarks of NXP B.V. All other product or service names are the property of their respective owners. All rights reserved.

© NXP B.V., 2009 - 2018. All Rights reserved.

Document Number: MPXV5050VC6T1  
Rev. 3  
12/2018







Компания «ЭлектроПласт» предлагает заключение долгосрочных отношений при поставках импортных электронных компонентов на взаимовыгодных условиях!

Наши преимущества:

- Оперативные поставки широкого спектра электронных компонентов отечественного и импортного производства напрямую от производителей и с крупнейших мировых складов;
- Поставка более 17-ти миллионов наименований электронных компонентов;
- Поставка сложных, дефицитных, либо снятых с производства позиций;
- Оперативные сроки поставки под заказ (от 5 рабочих дней);
- Экспресс доставка в любую точку России;
- Техническая поддержка проекта, помощь в подборе аналогов, поставка прототипов;
- Система менеджмента качества сертифицирована по Международному стандарту ISO 9001;
- Лицензия ФСБ на осуществление работ с использованием сведений, составляющих государственную тайну;
- Поставка специализированных компонентов (Xilinx, Altera, Analog Devices, Intersil, Interpoint, Microsemi, Aeroflex, Peregrine, Syfer, Eurofarad, Texas Instrument, Miteq, Cobham, E2V, MA-COM, Hittite, Mini-Circuits, General Dynamics и др.);

Помимо этого, одним из направлений компании «ЭлектроПласт» является направление «Источники питания». Мы предлагаем Вам помощь Конструкторского отдела:

- Подбор оптимального решения, техническое обоснование при выборе компонента;
- Подбор аналогов;
- Консультации по применению компонента;
- Поставка образцов и прототипов;
- Техническая поддержка проекта;
- Защита от снятия компонента с производства.



#### Как с нами связаться

**Телефон:** 8 (812) 309 58 32 (многоканальный)

**Факс:** 8 (812) 320-02-42

**Электронная почта:** [org@eplast1.ru](mailto:org@eplast1.ru)

**Адрес:** 198099, г. Санкт-Петербург, ул. Калинина, дом 2, корпус 4, литера А.